

PARTS AND FEATURES

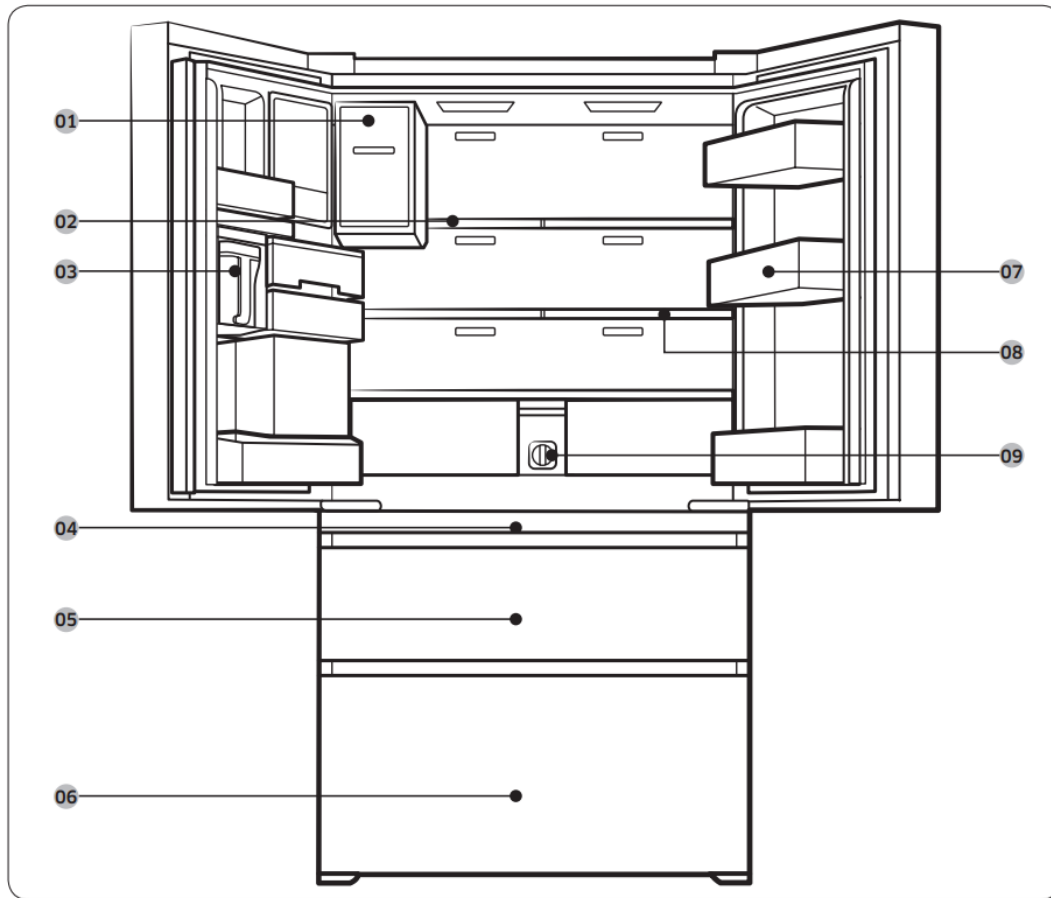

<p>01 Auto Ice Maker</p> <p>02 1-Step Foldable Shelf</p> <p>03 Water tank (Auto Water Fill)</p> <p>04 Main panel (on the FlexZone™ handle)</p> <p>05 FlexZone™</p>	<p>06 Freezer</p> <p>07 Door bins</p> <p>08 2-Step Foldable Shelf</p> <p>09 Water filter</p>
-------------------------------------------------------------------------------------------------------------------------------------------------------------------------------------------------------	--------------------------------------------------------------------------------------------------------------------------

• **NOTE**

- For energy efficiency, keep all shelves, drawers, and baskets in their original positions.
- When closing the door, make sure the vertical hinged section is in the correct position to avoid scratching the other door.
- If the vertical hinged section is reversed, put it back into the correct position, and then close the door.
- Moisture may form at times on the vertical hinged section.



- If you close a door forcefully, the other door may open.
- When a door opens, the interlock switch automatically disables the auger motor of the ice maker for safety reasons.
- If the internal or external LED lamp is out of order, contact a local Samsung service center.

OPERATIONS

Main panel

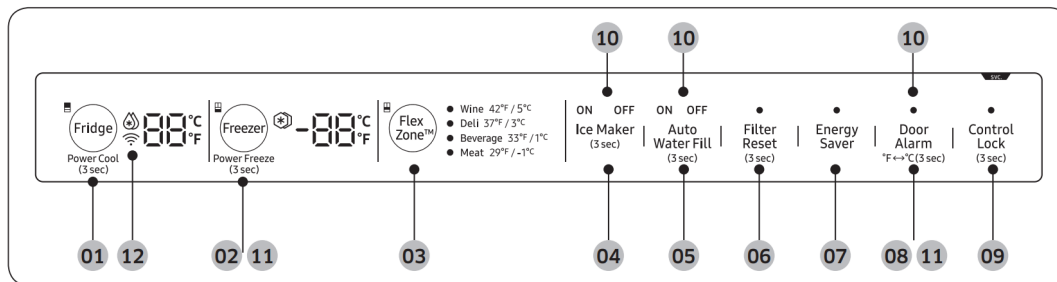

01 Fridge / Power Cool	07 Energy Saver
02 Freezer / Power Freeze	08 Door Alarm / °F ↔ °C
03 FlexZone™	09 Control Lock
04 Ice Maker	10 Cooling Off
05 Auto Water Fill	11 Sabbath Mode
06 Filter Reset	12 Network connection

NOTE

- When you change the temperature on the panel, the panel displays the actual temperature inside the refrigerator until the temperature matches the temperature you set. Then, the panel displays the new set temperature. Note that it will take time for the refrigerator to reach the new temperature. This is normal. During this time, you do not need to set the temperature again.
- To ensure optimal performance, we recommend setting the temperature to 0 °F (-18 °C) for the freezer, and 37 °F (3 °C) for the fridge.
- The temperature in the refrigerator may rise if you open the door frequently or put a large amount of food into the refrigerator. If this happens, the temperature display blinks until the refrigerator returns to the specified temperature settings.

- If a communication error occurs between the temperature display and the main controller, this blinking continues for an extended time. Contact a local Samsung service center for technical assistance.
- The display of the main panel turns on only if the door is opened and turns off if the door is closed.
- If you set Control Lock on the main panel, the main panel locks automatically 1 minute after inactivity.

01 Fridge / Power Cool (3 sec)

Fridge	<p>You can use the Fridge button to set the fridge temperature or to activate/deactivate Power Cool.</p> <p>Press Fridge repeatedly to select a desired temperature between 34 °F (1 °C) and 44 °F (7 °C). The temperature indicator displays the currently set or selected temperature.</p>
Power Cool	<p>Power Cool speeds up the cooling process at maximum power to lower the fridge temperature. The cooling process continues to run for several hours, and then the fridge returns to the previous temperature setting.</p> <p>Use Power Cool to rapidly cool food that spoils quickly or to rapidly cool the refrigerator after the door has been left open for some time.</p> <ul style="list-style-type: none"> • To activate Power Cool, press and hold Fridge for 3 seconds. <p>The corresponding indicator () lights up and the refrigerator speeds up the cooling process.</p> <ul style="list-style-type: none"> • To deactivate Power Cool, press and hold Fridge again for seconds. The fridge returns to the previous temperature setting. <p>NOTE</p> <p>Using Power Cool increases power consumption. Make sure you turn it off if you no longer need it and let the refrigerator return to its previous temperature.</p>

02 Freezer / Power Freeze (3 sec)

Freezer	<p>You can use the Freezer button to set the freezer temperature or to activate and de-activate Power Freeze.</p> <p>To set the freezer temperature manually, press Freezer repeatedly. The currently set or selected temperature appears on the temperature display. Available temperatures are between 5 °F (-15 °C) and -8 °F (-23 °C).</p>
Power Freeze	<p>Power Freeze speeds up the freezing process at maximum power to lower the freezer temperature. The freezing process continues to run for several hours, and then the freezer returns to the previous temperature setting with normal power.</p> <ul style="list-style-type: none">• To activate Power Freeze, press and hold Freezer for seconds. The corresponding indicator () lights up and the refrigerator speeds up the freezing process.• To de-activate Power Freeze, press and hold Freezer for 3 seconds again. The freezer returns to its previous temperature setting.• To freeze large amounts of food, activate Power Freeze for at least 20 hours before putting the food in the freezer. <p>NOTE</p> <p>Using Power Freeze increases power consumption. Make sure you turn it off if you no longer need it and let the refrigerator return to its previous temperature.</p>

03 FlexZone™

The FlexZone™ is a full-width drawer featuring temperature control. It has a temperature sensor that adjusts the amount of cold air allowed into the zone.

- Press FlexZone™ repeatedly to select a desired mode. By default, Deli is selected.
- The refrigerator adjusts the temperature in the FlexZone™ according to the selected mode.

Mode	Description	Examples
Wine	Select Wine to keep food fresh for a long time. The temperature of the FlexZone™ will be kept around 42 °F (5 °C).	Wine, cocktails, cake, cheese
Deli	Select Deli to keep food fresh for a longer time. The temperature of the FlexZone™ will be kept around 37 °F (3 °C).	Pineapples, lemons, biscuits, potatoes
Beverage	Select Beverage to keep drinks cold and refreshing. The temperature of the FlexZone™ will be kept around 33 °F (1 °C).	Bottled water, juice, soft drinks, beer
Meat	Select Meat to keep meat or fish fresh for a longer time. The temperature of the FlexZone™ will be kept around 29 °F (-1 °C).	Steaks, cold cuts, bacon, chili dogs

CAUTION

- Do not use the FlexZone™ to store most kinds of fruit or leafy vegetables. These food items may suffer cold-temperature damage.
- Do not store glass bottles in the FlexZone™ in Beverage or Meat mode. They may break and cause physical injury.

04 Ice Maker (3 sec)

Ice Maker	<p>Press and hold Ice Maker for more than 3 seconds to turn the ice maker on or off.</p> <p>The ice maker has 2 indicators (ON/OFF) to indicate the operating status.</p> <ul style="list-style-type: none"> • When the ice maker operates, the ON indicator turns on. • When the ice maker is turned off, the OFF indicator turns on. <p>In this case, ice making is disabled even if you press the Cubed or Crushed Ice buttons on the dispenser panel. To enable ice making, you must turn the ice maker on.</p> <p>NOTE</p> <p>If the ice maker is turned off, it will turn on if you press and hold the ice lever for more than 5 seconds.</p>
-----------	------------------------------------------------------------------------------------------------------------------------------------------------------------------------------------------------------------------------------------------------------------------------------------------------------------------------------------------------------------------------------------------------------------------------------------------------------------------------------------------------------------------------------------------------------------------------------------------------------------------------------------------------------------------------------------



05 Auto Water Fill (3 sec)

Auto Water Fill	<p>Press and hold Auto Water Fill for 3 seconds to turn the function on. Open the left door of the fridge, and then insert the water tank. Close the door and the water tank starts to be filled with water up to the a preset level some time later.</p> <p>To turn the function off, press and hold Auto Water Fill again for seconds.</p> <p>NOTE</p> <ul style="list-style-type: none">• By default, Auto Water Fill is disabled. Enable this function after you have installed the water line.• If you open the door or push the dispenser lever, this function is stopped temporarily.• While the water tank is filled with water, the mood light on the dispenser panel stays lit.• The Auto Water Fill indicators blink if there is a leak. This may occur because the water tank overflows, or the water-line or water-level sensor fails. If this is the case, follow these steps.<ol style="list-style-type: none">a. Open the rubber cap and drain water.b. When draining is complete, the indicators stop blinking and turn solid.c. Close the rubber cap.• If the indicators continue to blink, this might be a system failure. Contact a local service center.
-----------------	------------------------------------------------------------------------------------------------------------------------------------------------------------------------------------------------------------------------------------------------------------------------------------------------------------------------------------------------------------------------------------------------------------------------------------------------------------------------------------------------------------------------------------------------------------------------------------------------------------------------------------------------------------------------------------------------------------------------------------------------------------------------------------------------------------------------------------------------------------------------------------------------------------------------------------------------------------------------------------------------------------------------------------------------------------------------------------------------------------------------------------------------------------------------------------------------------------------------------------------------------------------------



06 Filter Reset (3 sec)

Filter Reset	<p>After about 6 months (and typically, about 300 gallons (1200 L) of water), the Filter indicator blinks red for several seconds when you open or close the door, reminding you that the filter needs to be replaced.</p> <p>When this happens, replace the filter, and then press and hold Filter Reset for 3 seconds. The filter lifecycle will be reset and the Filter indicator turns off.</p> <p>NOTE</p> <ul style="list-style-type: none">• Some regions have relatively large amounts of lime in their water. This can reduce the lifecycle of the filter. In these areas, you will have to replace the water filter more often than specified above.• If water is not dispensing properly, the water filter is most likely clogged. Replace the water filter.
--------------	-------------------------------------------------------------------------------------------------------------------------------------------------------------------------------------------------------------------------------------------------------------------------------------------------------------------------------------------------------------------------------------------------------------------------------------------------------------------------------------------------------------------------------------------------------------------------------------------------------------------------------------------------------------------------------------------------------------------------------------------------------------------------------------------------------

07 Energy Saver

Energy Saver	<p>Use Energy Saver mode to reduce power consumption.</p> <p>Press Energy Saver to turn on or off Energy Saver mode and the corresponding indicator. By default, Energy Saver mode is enabled.</p> <p>NOTE</p> <p>If condensation or water drops form on or around the doors, turn Energy Saver mode off.</p>
--------------	----------------------------------------------------------------------------------------------------------------------------------------------------------------------------------------------------------------------------------------------------------------------------------------------------------------------

08 Door Alarm / °F ↔ °C (3 sec)

Door Alarm	<p>If the door is left open for more than 2 minutes, an alarm will sound and the Alarm Indicator will blink. You can toggle the alarm on and off by pressing Door Alarm. The alarm is enabled by factory default.</p>
°F ↔ °C	<p>You can also use the Door Alarm button to switch the temperature scale between Celsius and Fahrenheit.</p> <p>To switch the temperature scale, press and hold Door Alarm for 3 seconds to change the current temperature scale.</p>

09 Control Lock (3 sec)

<p>Control Lock (Main panel)</p>	<p>To prevent accidental setting changes, press and hold Control Lock for 3 seconds. The main panel will be disabled and the Lock indicator (●) will turn on.</p> <p>When Control Lock is on, the indicator blinks if any button (except for the Control Lock button) on the main panel is pressed. If you press and hold the button again for more than 3 seconds, Control Lock will be deactivated. However, Control Lock will be reactivated if no button is pressed within 1 minute.</p> <p>NOTE</p> <p>Control Lock on the main panel does not affect the dispenser. The dispenser operates independently and so does the dispenser lever. To lock the dispenser and the dispenser lever, use the Lock function on the dispenser.</p>
<p>Device authentication</p>	<p>When connecting the refrigerator to SmartThings App or Samsung smart devices such as Samsung Smart TVs, follow the app's or device's onscreen instructions and press and hold Control Lock for 5 seconds. The temperature panel displays "on" for 5 seconds before proceeding with the authentication procedure. Note that the Control Lock function will be not affected by this authentication.</p>

Cooling Off

Cooling Off mode (also called Shop mode), is designed for use by retailers when they are displaying refrigerators on a retail floor.

In Cooling Off mode, the refrigerator's fan motor and lights operate normally, but the compressors do not run so that neither the refrigerator nor the freezer get cold.

To enter Cooling Off mode, press and hold Ice Maker, Auto Water Fill, and Door Alarm for seconds.

The refrigerator chime sounds, and the refrigerator shows O on the fridge display and FF on the freezer display.

11 Sabbath Mode

The Sabbath mode stays active for 85 hours once it is activated. After that, it will be deactivated automatically.

- To activate, press and hold Freezer and Door Alarm simultaneously for 5 seconds to enter Sabbath mode. Then the refrigerator operates in Sabbath mode where the buttons, the display, and the room lamps are all under control.
- To deactivate, press and hold the buttons again for 5 seconds to exit Sabbath mode.

NOTE

Even after the refrigerator powers off and restarts, the Sabbath mode remains active. To exit, you must deactivate it first.

12 Network connection (applicable models only)

You can use the optional Smart Home Adapter (sold separately) to control and monitor your refrigerator through the SmartThings app. For more information about SmartThings, see the SmartThings (applicable models only) section.

SmartThings

Installation

Visit the Google Play Store, Galaxy Apps, or Apple App Store and search for “SmartThings”.

Download and install the SmartThings app provided by Samsung Electronics to your smart device.

NOTE

- The SmartThings app is designed for Android 6.0 (Marshmallow) or later, iOS 10.0 or later, iPhone 6 or later, and is optimized for Samsung smartphones (Galaxy S and Galaxy Note series).
- For improved performance, the SmartThings app is subject to change without notice or discontinued support according to the manufacturer’s policy.
- Recommended encryption systems include WPA/TKIP and WPA2/AES. Any newer or non-standard Wi-Fi authentication protocols are not supported.
- Wireless networks may be affected by the surrounding wireless communication environment.
- If your Internet service provider has registered the MAC address of your PC or modem for identification, your Samsung Smart Refrigerator may fail to connect to the Internet.
- If this happens, contact your Internet service provider for technical assistance.

- The firewall settings of your network system may prevent your Samsung Smart Refrigerator from accessing the Internet. Contact your Internet service provider for technical assistance. If this symptom continues, contact a local Samsung service center or retailer.
- To configure the wireless access point (AP) settings, see the user manual of the AP router).
- Samsung Smart Refrigerators support both Wi-Fi 2.4 GHz with IEEE 802.11 b/g/n and Soft-AP protocols. (IEEE 802.11 n is recommended.)
- Unauthorized Wi-Fi wireless routers may fail to connect to applicable Samsung Smart Refrigerators.

Samsung account

You are required to register your Samsung account to use the app. If you don't have a Samsung account, follow the app's onscreen instructions to create a free Samsung account.

Getting started

Turn on the device you want to connect, open the SmartThings app on your phone, and then follow the instructions below.

If a pop-up appears saying that a new device has been found, tap ADD NOW.

If a pop-up doesn't appear, tap the + button, and then select the device you want to connect from the list of available devices.

If your device isn't in the list of available devices, tap Supported Devices, select the device type (Refrigerator), and then select the specific device model.

Follow the instructions in the app to set up your device. Once setup is complete, your refrigerator will appear as a "card" on your Devices screen.

Refrigerator app

Integrated control

You can monitor and control your refrigerator at home and on the go.

- Tap the refrigerator icon on the SmartThings Dashboard or tap the Devices icon at the bottom of the Dashboard, and then tap the refrigerator "card" to open the Refrigerator page.
- Check the operation status or notifications related to your refrigerator, and then change options or settings if necessary.

NOTE

Some options or settings of the refrigerator may not be available for remote control.

Category	Item	Description
Monitoring	Fridge temperature	Displays the current temperature setting of the fridge.
	Freezer temperature	Displays the current temperature setting of the freezer.
	FlexZone™ settings	Displays the settings of the FlexZone™.
	Diagnosis	Detects abnormal operations of the refrigerator.
	Energy monitoring	Checks the accumulated power consumption of the refrigerator for the last 180 days.
Functions	Ice making	You can turn the ice making function on or off, and check the current settings of the function.
		You can also check the status and progress of ice making.
	Power Cool	You can turn Power Cool on or off, and check the current settings.
Power Freeze	You can turn Power Freeze on or off, and check the current settings.	
Alarms	Abnormally high temperature	This alarm is triggered when the fridge, the freezer, or the FlexZone™ has abnormally high temperatures.
	Door opening	This alarm is triggered if the fridge door, the freezer drawer, or the FlexZone™ drawer is open for a specific time.
	Auto Water Fill overflowing	If the Auto Water Fill function senses an overflow, it triggers this alarm to let you know the status of the overflow.
	Water filter replacement	This alarm reminds you that the water filter must be replaced.

Dispenser panel

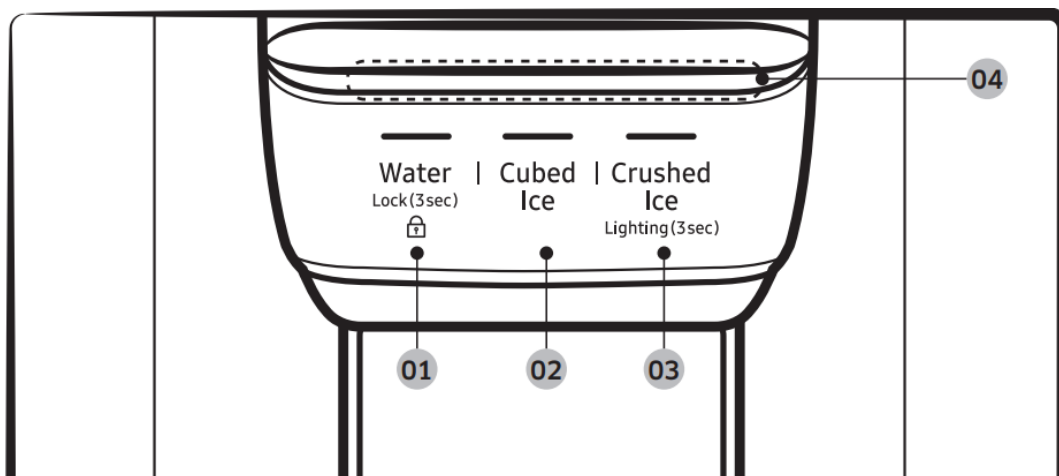

01 Water / Lock 02 Cubed Ice	03 Crushed Ice / Lighting 04 Dispenser mood light
---------------------------------	------------------------------------------------------

01 Water / Lock (3 sec)

Water	To dispense chilled water, press Water. The corresponding indicator turns on.
Lock (Dispenser panel / Dispenser lever)	To prevent use of the dispenser panel buttons and the dispenser lever, press and hold Water for more than 3 seconds. If you press and hold the button again for more than 3 seconds, the dispenser lock will be deactivated. NOTE The Lock on the dispenser panel does not affect the controls on the main panel. To lock the main panel, use the Control Lock function on the main panel.

02 Cubed Ice

Cubed Ice	Press Cubed Ice to dispense cubed ice. The corresponding indicator turns on.
-----------	------------------------------------------------------------------------------

03 Crushed Ice / Lighting (3 sec)

Crushed Ice	Press Crushed Ice to dispense crushed ice. The corresponding indicator turns on.
Lighting	By default, the dispenser lamp turns on only when the dispenser is used. To keep the dispenser lamp turning on, press and hold Crushed Ice for 3 seconds. To turn the lamp off, press and hold Crushed Ice for 3 seconds again

05 Dispenser mood light

The Dispenser mood light lights up in the following conditions:

- When you push the dispenser lever with the dispenser lock disabled
 - Push the dispenser lever and the dispenser mood light turns on. Release the lever and the light turns off after a some time.

- While the water tank is being filled with water with the Auto Water Fill function turned
 - The dispenser mood light stays lit.

Special features

Water tank (Auto Water Fill)

The Auto Water Fill function lets you enjoy cold brewed tea in your refrigerator.

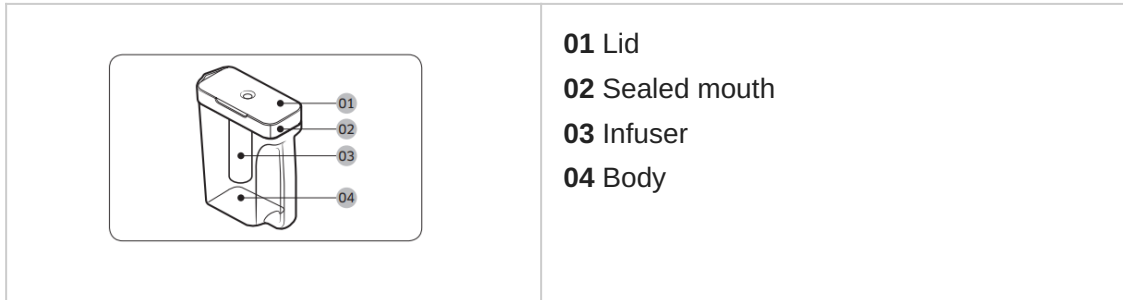



To fill the water tank

	<ol style="list-style-type: none"> 1. Grasp a handle groove of the sealed mouth, and then pull up to open the lid. 2. Put tea leaves or fruits to your taste into the infuser. <p>NOTE If you want to keep the infused water in its initial concentration, turn the Auto Water Fill function off</p>
	<ol style="list-style-type: none"> 3. Enable the Auto Water Fill function on the main panel. Open the left door of the fridge door, and then mount the water tank onto the holder. Push it straight in as shown in the illustration on the left. 4. Close the door. The infuser will start to fill with chilled water some time later.
	<ol style="list-style-type: none"> 5. To drink tea, open the door and detach the water tank. Pull it straight out.

CAUTION Make sure the infuser fits in the water tank holder.

- We recommend consuming fruit infused water within 24 hours. After that, the infused water can spoil over time.
- You must clean the water tank after you have consumed up the infused water or when a long time has passed without using the water tank.

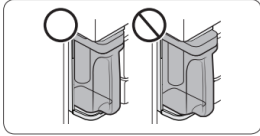
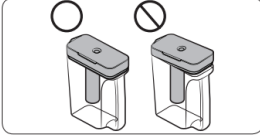

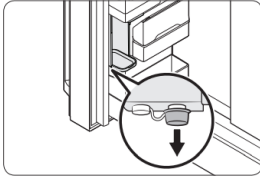
	<ul style="list-style-type: none"> • To prevent the water tank from tipping over or leaking, make sure the water tank fits in the water tank holder.
	<ul style="list-style-type: none"> • To prevent the water tank from spilling over or leaking, make sure the sealed mouth is properly inserted.
	<p>NOTE</p> <ul style="list-style-type: none"> • If the front side (specifically marked area) of the water tank has too much moisture, the water tank may not fully fill. Remove the moisture, and then try again. • Auto Water Fill will stop supplying water for the water tank if the water tank does not fill after a certain amount of time. If this happens, check if the water line is properly connected. <p>Remove and reinsert the water tank, and then try again.</p>
	<p>NOTE</p> <ul style="list-style-type: none"> • Wipe around the infuser holder if the infuser overflows or leaks. • Water drops off if the rubber cap is opened. • The Auto Water Fill indicator blinks if there is a leak. In case of a leak, open the rubber cap so that the leaked water drains. The indicator will then turn off. However, if the indicator continues to blink, there might be a system failure. Contact your local Samsung service center. • The Auto Water Fill indicators blink if there is a leak.

Water/Ice dispenser

Using the dispenser, you can dispense water with or without ice.

The water dispenser offers 3 options: chilled water, cubed ice, and crushed ice. To dispense chilled water, press Water on the dispenser panel. Put a water glass under the dispenser, and then push the dispenser lever.

To dispense water with ice

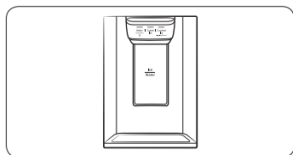

1. With the Ice Maker enabled, press Cubed Ice or Crushed Ice to select the ice type.
2. Put a water glass under the dispenser, and then push the dispenser lever with the glass. Ice will be dispensed from the dispenser.
3. Press Water to select water.
4. Push the dispenser lever with the glass. Water will be dispensed from the dispenser.

NOTE

- The dispenser will stop dispensing if you keep pushing the dispenser lever for about 1 minute. To dispense more water, release and push the lever again.
- Make sure the glass is in line with the dispenser to prevent the dispensed water from spilling out.
- If you do not use the water dispenser for 2-3 days, the dispensed water may have an abnormal smell or taste. This is not a system failure. Discard the first 1-2 glasses of water.

Ice maker

The refrigerator has a built-in ice maker that automatically dispenses ice so that you can enjoy filtered water with cubed or crushed ice.

Ice making

After you have installed your refrigerator and plugged it in, follow these instructions to ensure proper ice making and to keep the ice bucket full of ice:

1. Let the refrigerator operate for at least 24 hours to ensure optimal performance.
2. Dispense the first 4 to 6 ice cubes into a glass.
3. Wait another 8 hours and dispense another 4 to 6 ice cubes.
4. Then, wait another 16 hours and dispense the first glass-full of ice.

NOTE

- If you consume all the ice at once, you must wait 8 hours before dispensing the first 4 to 6 cubes. This ensures that the ice bucket is filled with ice properly.
- Ice cubes generated rapidly may look white, which is normal.

Diagnosis

	<p>If ice does not dispense, first check the ice maker.</p> <ol style="list-style-type: none">1. Press Test on the side of the ice maker.2. You will hear a chime (ding-dong) when you press the button. You will hear another chime if the ice maker is operating properly.
--	-----------------------------------------------------------------------------------------------------------------------------------------------------------------------------------------------------------------------------------------------------------------------------------------------------

CAUTION

- If the ice making chime rings repeatedly, contact your waterline installer or a local Samsung service center.
- Do not press Test repeatedly after the ice tray is filled with ice or water. Water may overflow or ice may jam.
- Do not put food in the ice bucket. The frozen food may damage the ice maker, especially when you open or close the door.
- When the refrigerator recovers power after a power failure, the ice bucket may contain a mix of melted and jammed ice cubes, which can prevent the ice maker from working properly. To prevent this, make sure to empty the ice bucket so the ice bucket can refill with fresh, loose ice cubes.
- Do not put fingers or any objects into the dispenser outlet or the ice maker. This can cause physical injury or property damage.
- When reinserting the ice maker tray, make sure that the tray is properly centered at the entrance. Otherwise, the tray can get stuck.

If You Turn the Ice Maker Off

If you press and hold Ice Maker for more than 3 seconds to turn the ice maker off, make sure to remove all ice cubes from the ice bucket. Remaining ice cubes may clump together, making it difficult to remove them.

To remove the ice bucket, see the Ice bucket section.

NOTE Removal of the ice bucket does not affect the thermal and mechanical performance of the refrigerator.

Water clouding

Water supplied to the refrigerator flows through a core alkaline filter. During this filtering process, the water pressure of the water increases and the water becomes saturated with oxygen and nitrogen. This causes the water to look misty or cloudy temporarily when dispensed. This is normal and the water will look clear after a few seconds

FlexZone™ divider

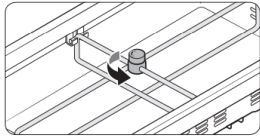

You can change the divider position. To do this, unlock the divider by turning the divider dial counter clockwise. Then, move the width and height bars as appropriate. When done, turn the dial clockwise to lock the divider.

NOTE If the divider lock does not function, wipe the bars to remove moisture on them.

MAINTENANCE

Handling and care

Ice bucket

If you do not dispense ice for an extended period, ice may form clumps inside the bucket. If this happens, remove and empty the ice bucket.

	1. While grabbing the handle of the ice bucket, slightly lift up the bucket, and then remove it to the front.
	2. Remove the remaining ice cubes and put the ice bucket back into place.
	If the ice bucket is not firmly inserted, turn the ice screw 90 degrees, and then try again.

CAUTION

- Do not apply excessive force to the bucket cover. The cover may break.
- Do not forcefully close the door. Water may spill over the ice maker.
- To prevent injury, make sure to clean up any ice or water that has spilled on the floor.

- To prevent accidents or injury, do not let children play with the water dispenser or the ice maker.
- Do not put your hand or an object into the ice chute. This may cause physical injury or product damage.
- Use only the provided ice bucket. Third-party ice buckets may cause a system failure.
- Use only potable water that is connected to the water supply line.

NOTE

- The water pressure required for ice making is between 20 psi and 125 psi.
- Noise from the ice maker as it produces ice during the ice making process is normal.
- While the door is open, neither the ice maker nor the water dispenser operates.

Auto Water Fill

	1. Grasp a handle groove of the sealed mouth, and then pull up to remove.
	2. Grasp both sides of the sealed mouth, and then lift to remove.
	3. While slightly twisting the infuser, pull it out of the sealed mouth. 4. Clean the infuser with neutral agents and running water. Rinse and dry well. 5. Reassemble the Auto Water Fill in the reverse order of disassembly.

Fridge shelves

The appearance of the shelves differs by model.

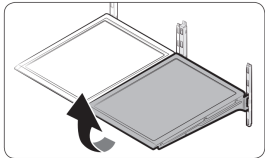
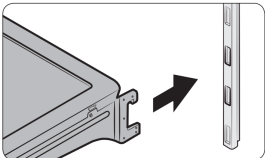
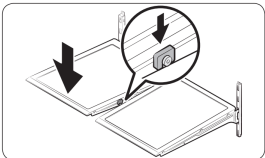

	<ul style="list-style-type: none"> • To remove a shelf, fully open the corresponding door. Hold the front of the shelf, and then gently lift up and slide out. <p>NOTE Do not lift up the shelf fully when removing or reinserting the shelf. The rear wall of the fridge room can be dented.</p>
	<ul style="list-style-type: none"> • To reinsert, hold the shelf at an angle so the front is higher than the back, and then insert the top hook into the top shelf notch. Then, lower the shelf and insert the bottom shelf hook into the bottom shelf notch.
	<p>CAUTION</p> <ul style="list-style-type: none"> • The tempered glass shelves are heavy. Use caution when removing them. • The shelf must be inserted correctly. Do not insert upside down. • Glass containers may scratch the surface of glass shelves.

Foldable shelf

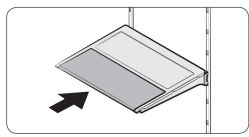
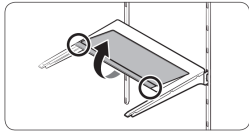
	<p>To remove, slide up the front of the shelf so that it folds. Then gently lift up and pull out. To reinsert, place the shelf on the angled frame in the main unit, and then, press down to unfold.</p>
	<p>CAUTION</p> <p>After sliding the foldable shelf in and folding it, the front of the shelf can be removed for your convenience. If you use the shelf without removing the front of the shelf, be aware that it can separate from the rear portion, be careful of its possible separation.</p>

Recommended foldable shelf location

	<p>The foldable shelf folds up from the center, giving you more room for storage.</p> <ul style="list-style-type: none">• Insert the shelf in the right side of the fridge. Left side insertion does not allow the shelf to fold completely.• To fold, push the front area of the shelf inward so that it folds up from the middle. <p>CAUTION Do not lift up quickly or twist the foldable shelf to take out food under it. It may fall off.</p>
--	---------------------------------------------------------------------------------------------------------------------------------------------------------------------------------------------------------------------------------------------------------------------------------------------------------------------------------------------------------------------------------------------------------------------------------------------------------------------------------

Vegetable shelf

	<p>1. Slide out the left-side vegetable drawer</p>
	<p>2. Fully open the door, and then remove the shelf.</p>
	<p>3. While supporting the vegetable shelf with one hand, slide it out with the other hand.</p> <p>NOTE To use the space that is opened up after removing the foldable shelf, take out the vegetable shelf. To reinsert, follow the steps above in the reverse order.</p>

Door Bins

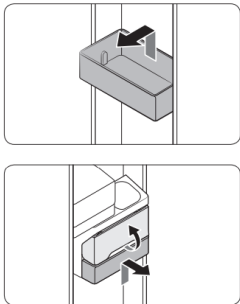
	<ul style="list-style-type: none">• To remove - hold the front sides of the bin, and then gently lift up to remove.• To reinsert - insert the door bin slightly above its final location making sure that the back of the bin is against the door. Hold the rear of the door bin with both hands, and then press down so that it fits snugly.
-------------------------------------------------------------------------------------	----------------------------------------------------------------------------------------------------------------------------------------------------------------------------------------------------------------------------------------------------------------------------------------------------------------------------------------------------------------------

CAUTION

- Do not remove a bin that is filled with food. Empty the bin beforehand.

- Use caution when opening the door if the bottom bin contains larger bottles, which may fall over.
- Do not allow children to play with the bins. Sharp corners of the bin may cause injury.

Fridge drawers

Vegetable / fruit drawers

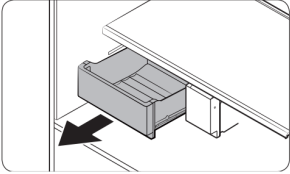
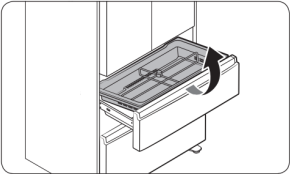
	<p>Gently lift up the front of the drawer and slide out.</p> <ul style="list-style-type: none"> • We recommend that you remove the door bins before removing the drawer. This is to prevent damage to the door bins. • To reinsert, insert the drawer into the frame rails and then slide inward.
<p>FlexZone™ basket</p> 	<ul style="list-style-type: none"> • To remove, fully open the FlexZone™ drawer. Lift up the FlexZone™ basket, and then pull out with both hands. • To reinsert, fully open the FlexZone™ drawer. While tilting up the front of the basket, insert the rear of the basket into the rail assembly. Lower the front until the basket settles down. • If the divider lock does not function, wipe the bars to remove moisture on them.

To remove the divider and the metal cooling plate (applicable models only) from the FlexZone™ basket

	<ol style="list-style-type: none"> 1. Unlock the divider by turning the divider dial counter clockwise. 2. Slide the divider to the end as shown.
	<ol style="list-style-type: none"> 3. As the divider has the width and length bars, push the lower part of each bar inward to unlock. See the figures for details.
	<ol style="list-style-type: none"> 4. Hold the divider and pull up to remove.
	<ol style="list-style-type: none"> 5. Turn over the basket to remove the metal cooling plate.

CAUTION

The basket and the metal cooling plate are heavy. Use caution when handling them. Careless handling may cause personal injury or property damage.

To reinsert the metal cooling plate

Reinsertion in the reverse order of removal.

Reinsert the divider into the FlexZone™ basket firmly until you hear a clicking sound.

Freezer baskets

<i>Upper basket</i>	<ul style="list-style-type: none"> • To remove, fully slide open the freezer drawer. Push the upper basket to the end, and then pull up to remove. • To reinsert, align the front wheels of the upper basket with the end of the lower basket. Slide the upper basket to the front.
<i>Lower basket</i>	<ul style="list-style-type: none"> • To remove, first remove the upper basket. Then, tilt up the front of the lower basket to pull out. • To reinsert, put the basket into the rail assembly with the rear side first.

• **CAUTION**

Do not twist the basket when removing or reinserting the basket. The basket can be scratched.

- To prevent physical injury, property damage, or suffocation, keep children away from freezer baskets that have been removed.
- Do not remove the divider.



- Put the wheels of the upper basket on the end of the rails of the lower basket. Then, slide the upper basket all the way to the front. Otherwise, the drawer does not open or close properly, which causes frost to build up.

Cleaning

Interior and exterior

WARNING

- Do not use benzene, thinner, home/car detergent, or Clorox™ to clean the refrigerator. They may damage the surface of the refrigerator and cause a fire.
- Do not spray water onto the refrigerator. This may cause electric shock.

Regularly use a dry cloth to remove all foreign substances such as dust or water from the power plug terminals and contact points.

1. Unplug the power cord.
2. Use a moistened, soft, lint-free cloth or paper towel to clean the refrigerator's interior and exterior.
3. When done, use a dry cloth or paper towel to dry well.
4. Plug in the power cord.

Ice / Water dispenser

CAUTION

When crushed ice is selected, some residual ice chips may collect in the ice chute. To prevent this, remove the residual ice from the chute using a soft, clean cloth.

Rubber seals

If the rubber seals of a door become dirty, the door may not close properly and reducing refrigerator performance and efficiency. Use a mild detergent and damp cloth to clean the rubber seals. Then, dry well with a cloth.

Rear panel

	To keep cords and exposed parts of the rear panel free of dirt, vacuum the panel once or twice a year.
--	--------------------------------------------------------------------------------------------------------

CAUTION Do not remove the rear panel cover. Electric shock may occur.

Replacement

Water filter

WARNING

- Do not use third-party water filters. Use only Samsung-provided or -approved filters.
- Unapproved filters may leak and damage the refrigerator, causing electric shock. Samsung is not responsible for any damage that may occur from use of third-party water filters.

The Filter Reset indicator (●) turns red to let you know it is time to replace the water filter. Before replacing the filter, make sure the water supply line is shut off.

	<ol style="list-style-type: none">1. While opening the filter cover, turn the knob of the filter cartridge counter clockwise by 90 degrees (1/4 turn). The filter cartridge unlocks.2. Pull out to remove the cartridge.<ul style="list-style-type: none">- If the water filter is severely contaminated, the cartridge may not be easily removable. In that case, use force to pull it out.- To prevent water leaks from the opening, pull the cartridge straight out while removing it.
	NOTE To prevent overflow, empty and dry the water filter tray.
	<ol style="list-style-type: none">3. Insert a new filter cartridge. Use only Samsung-provided or approved filters.
	<ol style="list-style-type: none">4. Turn the cartridge knob clockwise to lock into place.5. Press and hold Filter Reset on the main panel for 3 seconds to reset the life cycle detector. The Filter Reset indicator ● turns off.6. When you are done replacing the filter, open the water valve and run water through the dispenser for about 7 minutes. This is to remove impurities and air from the water line.

NOTE

- A newly installed filter may cause the water dispenser to spurt water briefly. This is because air has entered the waterline.
- The replacement process may cause the water dispenser to drip for a short period of time. If it drips, simply wipe up any water on the floor with a dry towel.

Reverse osmosis water filtration system

The water pressure of the water supply system to a reverse osmosis water filtration system must be between 35 psi and 120 psi (241 kPa and 827 kPa).

The water pressure of the reverse osmosis water filtration system to the refrigerator's cold water line must be at least 40 psi (276 kPa). If the water pressure is below these specifications:

- Check if the sediment filter in the reverse osmosis system is blocked. Replace the filter if necessary.
- Refill the water tank in the reverse osmosis system with water.
- If your refrigerator has a water filter, it may further reduce the water pressure when used in conjunction with a reverse osmosis system. Remove the water filter.

LED Lamps

To replace the lamps of the refrigerator, contact a local Samsung service center.

WARNING

- The lamps are not user-serviceable. Do not attempt to replace a lamp yourself. This can cause electric shock.

To relocate the divider - Hook the back of the divider over the rear wall of the pantry and push the divider down.

TROUBLESHOOTING

General Temperature

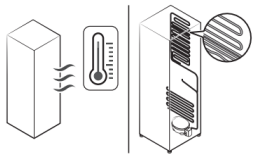

Symptom	Possible causes	Solution
Fridge/freezer does not operate. Fridge/freezer temperature is warm.	<ul style="list-style-type: none"> • Power cord is not plugged in properly. 	<ul style="list-style-type: none"> • Properly plug in the power cord.
	<ul style="list-style-type: none"> • Temperature control is not set correctly. 	<ul style="list-style-type: none"> • Set the temperature lower.
	<ul style="list-style-type: none"> • Refrigerator is located near a heat source or direct sunlight. 	<ul style="list-style-type: none"> • Keep the refrigerator away from direct sunlight or a heat source.
	<ul style="list-style-type: none"> • Not enough clearance between refrigerator and nearby walls or cabinets. 	<ul style="list-style-type: none"> • Make sure there is a gap of at least 2.5 inches (5 cm) between the refrigerator back and sides and any nearby walls or cabinets.
	<ul style="list-style-type: none"> • Energy Saver mode is activated. 	<ul style="list-style-type: none"> • Deactivate Energy Saver mode.
	<ul style="list-style-type: none"> • The refrigerator is overloaded. Food is blocking the refrigerator vents. 	<ul style="list-style-type: none"> • Do not overload the refrigerator. Do not allow food to block vents.
Fridge/freezer is over-cooling.	<ul style="list-style-type: none"> • Temperature control is not set correctly. 	<ul style="list-style-type: none"> • Set the temperature higher.
Interior wall is hot.	<ul style="list-style-type: none"> • Refrigerator has heat-proof piping in the interior wall. 	<ul style="list-style-type: none"> • To prevent condensation from forming, the refrigerator has heat-proof piping in the front corners. If the ambient temperature rises, this equipment may not work effectively. This is not a system failure. 

Odors

Symptom	Possible causes	Solution
Refrigerator has odors.	• Spoiled food.	• Clean the refrigerator and remove any spoiled food.
	• Food with strong odors.	• Make sure strong smelling food is wrapped airtight.

Frost

Symptom	Possible causes	Solution
Frost around the vents.	• Food is blocking the vents.	• Make sure no food blocks the refrigerator vents.
Frost on interior walls.	• Door is not closed properly.	• Make sure food does not block the door. Clean the door gasket.
Fruits or vegetables are frozen.	• Fruits or vegetables are stored in the FlexZone.	• Do not store most kinds of fruit or vegetables in the FlexZone.

Condensation

Symptom	Possible causes	Solution
Condensation forms on the interior walls.	• If door is left open, moisture enters the refrigerator.	• Remove the moisture and do not leave a door open for extended periods of time.
	• Food with high moisture content.	• Make sure food is wrapped airtight.

Water/ice (dispenser models only)

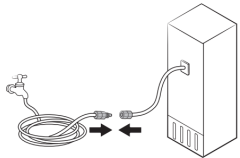

Symptom	Possible causes	Solution
Water flow is weaker than normal.	<ul style="list-style-type: none"> Water pressure is too low. 	<ul style="list-style-type: none"> Make sure the water pressure is between 20 to 120 psi.
Ice maker makes a buzzing sound.	<ul style="list-style-type: none"> The ice maker function is activated, but the water supply to the refrigerator has not been connected. 	<ul style="list-style-type: none"> Activate the Ice Maker off.
Ice maker does not make ice.	<ul style="list-style-type: none"> Ice maker has just been installed. 	<ul style="list-style-type: none"> You must wait for 12 hours for the refrigerator to make ice.
	<ul style="list-style-type: none"> Freezer temperature is too high. 	<ul style="list-style-type: none"> Set the freezer temperature below 0 °F (-18 °C) or -4 °F (-20 °C) in warm ambient air.
	<ul style="list-style-type: none"> Dispenser Lock is activated. 	<ul style="list-style-type: none"> Deactivate dispenser Lock.
	<ul style="list-style-type: none"> Ice maker is off. 	<ul style="list-style-type: none"> Turn on the ice maker.
Ice does not dispense.	<ul style="list-style-type: none"> Ice may jam if the ice dispenser is not used for a long time (approx. 3 weeks). 	<ul style="list-style-type: none"> If you won't be using the refrigerator for a long time, empty the ice bucket and turn off the ice maker.
	<ul style="list-style-type: none"> Ice bucket is not properly inserted. 	<ul style="list-style-type: none"> Make sure the ice bucket is properly inserted.
	<ul style="list-style-type: none"> Water line is not connected properly or water supply is not on. 	<ul style="list-style-type: none"> Check if the water line is installed correctly. Check if the water line stop cock is closed. 
Water does not dispense.	<ul style="list-style-type: none"> Water line is not connected properly or water supply is not on. 	<ul style="list-style-type: none"> Check if the water line is installed correctly. Check if the water line stop cock is closed.

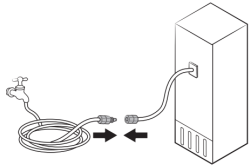
Symptom	Possible causes	Solution
		
	<ul style="list-style-type: none"> • Dispenser Lock is activated 	<ul style="list-style-type: none"> • Deactivate dispenser Lock.
	<ul style="list-style-type: none"> • A third-party water filter was installed. 	<ul style="list-style-type: none"> • Use only Samsung-provided or approved filters. • Unapproved filters may leak and damage the refrigerator.
	<ul style="list-style-type: none"> • Water filter indicator turns on or blinks. 	<ul style="list-style-type: none"> • Replace the water filter. After replacing, reset the filter indicator sensor.

Do you hear abnormal sounds from the refrigerator?

These sounds are normal.

- When starting or ending an operation, the refrigerator may make sounds similar to a car engine ignition. As the operation stabilizes, the sounds will decrease.

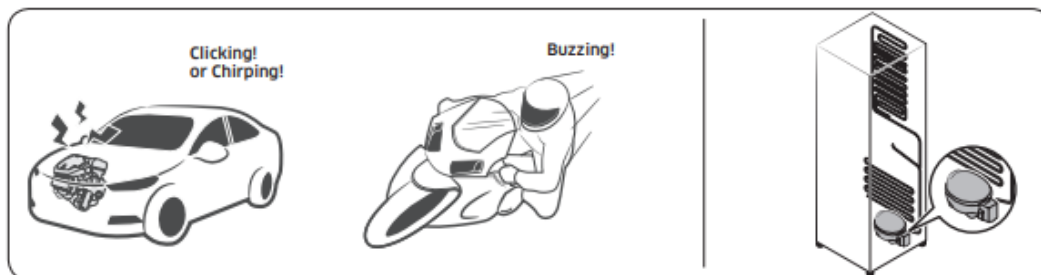

- While the fan is operating, these sounds may occur. When the refrigerator reaches the set temperature, the fan sound will stop. S



- During a defrost cycle, water may drip on the defrost heater, causing sizzling sounds



- As the refrigerator cools or freezes, refrigerant gas moves through sealed pipes, causing bubbling sounds.

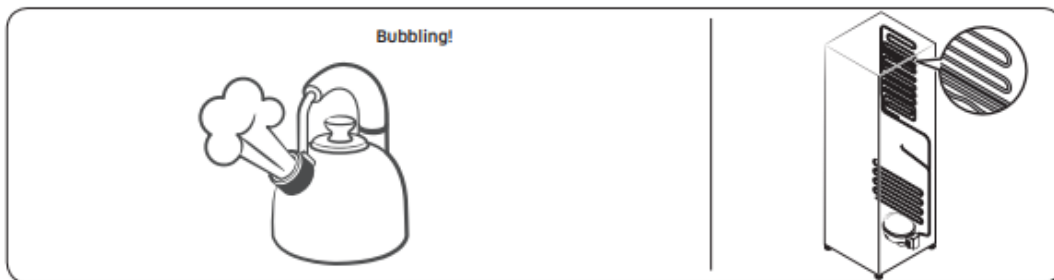

- As the refrigerator temperature increases or decreases, plastic parts contract and expand, creating knocking noises. These noises occur during the defrosting cycle or when electronic parts are working.

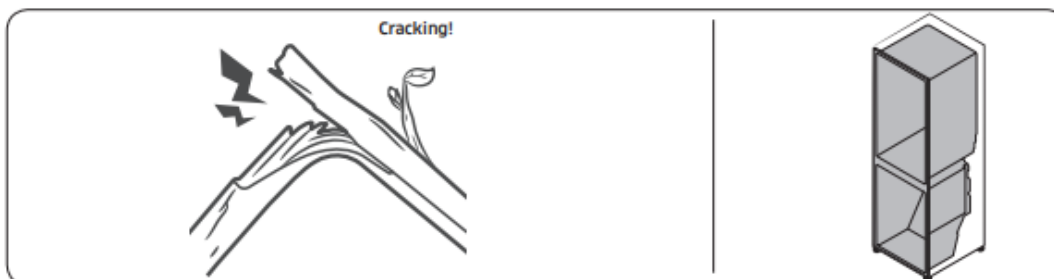

- For ice maker models: When the water valve opens to fill the ice maker, buzzing sounds may occur.
- Due to pressure equalizing when you open and close the refrigerator door, whooshing sounds may occur.

SmartThings

Symptom	Action
Could not find “SmartThings” in the app market.	<ul style="list-style-type: none"> The SmartThings app is available for smartphones that run Android 6.0 (Marshmallow) or higher, or iOS 9.0 or later, and is optimized for Samsung smartphones (Galaxy S and Galaxy Note series).
The SmartThings app fails to operate.	<ul style="list-style-type: none"> The SmartThings app is available for applicable models only. The old Samsung Smart Refrigerator app cannot connect with Samsung Smart Home models.
The SmartThings app is installed but is not connected to my refrigerator.	<ul style="list-style-type: none"> You must log into your Samsung account to use the app. Make sure that your router is operating normally. If you have not connected your refrigerator to the SmartThings App after the app was installed, you must make the connection using the device registration function of the app.
Could not log into the app.	<ul style="list-style-type: none"> You must log into your Samsung account to use the app. If you don't have a Samsung account, follow the app's onscreen instructions to create one.
An error message appears when I try to register my refrigerator.	<ul style="list-style-type: none"> Easy Connection may fail due to the distance from your access point (AP) or electrical interference from the surrounding environment. Wait a moment and try again.
The SmartThings app is successfully connected to my refrigerator but does not run.	<ul style="list-style-type: none"> Exit and restart the SmartThings app or disconnect and reconnect the router. Unplug the power cord of the refrigerator, and then plug it in again after 1 minute.

Warning

This content is compiled from multiple sources and is provided for reference purposes only. It may not be complete or fully applicable to all situations. If you are unable to resolve your issue, please contact the product manufacturer or an authorized service provider for official support.

