

## PRODUCT OVERVIEW

### Product Features

The images in this guide may be different from the actual components and accessories, which are subject to change by the manufacturer without prior notice for product improvement purposes.

#### Exterior

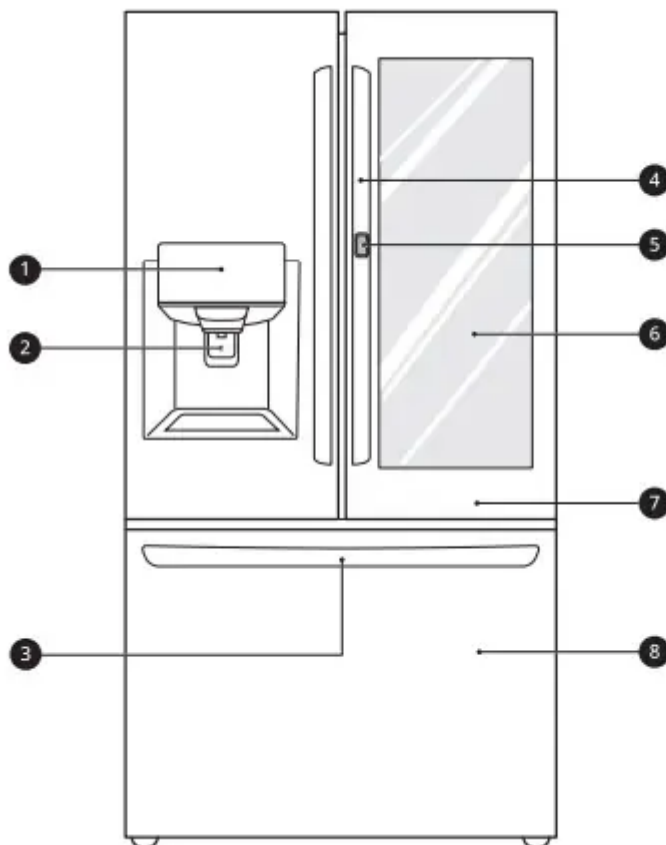

#### 1. Control Panel

- Sets the refrigerator temperature and freezer temperature, the water filter condition and the dispenser mode

#### 2. Filtered Water and Ice Dispenser

- Dispenses purified water and ice.

#### 3. SmartPull™ Handle

- Easily opens the freezer door

#### 4. Handle

- Opens and closes the refrigerator door.

## 5. Door Button†

- Opens the Door-in-Door Compartment.

## 6. Door Button†

- Opens the Door-in-Door Compartment.

## 7. Refrigerator

- Fresh food compartment

## 8. Freezer

- Frozen food compartment

† This feature is only available on some models.

## Interior

InstaView Door-in-Door: LRFVS3006\* / LRFVC2406\*

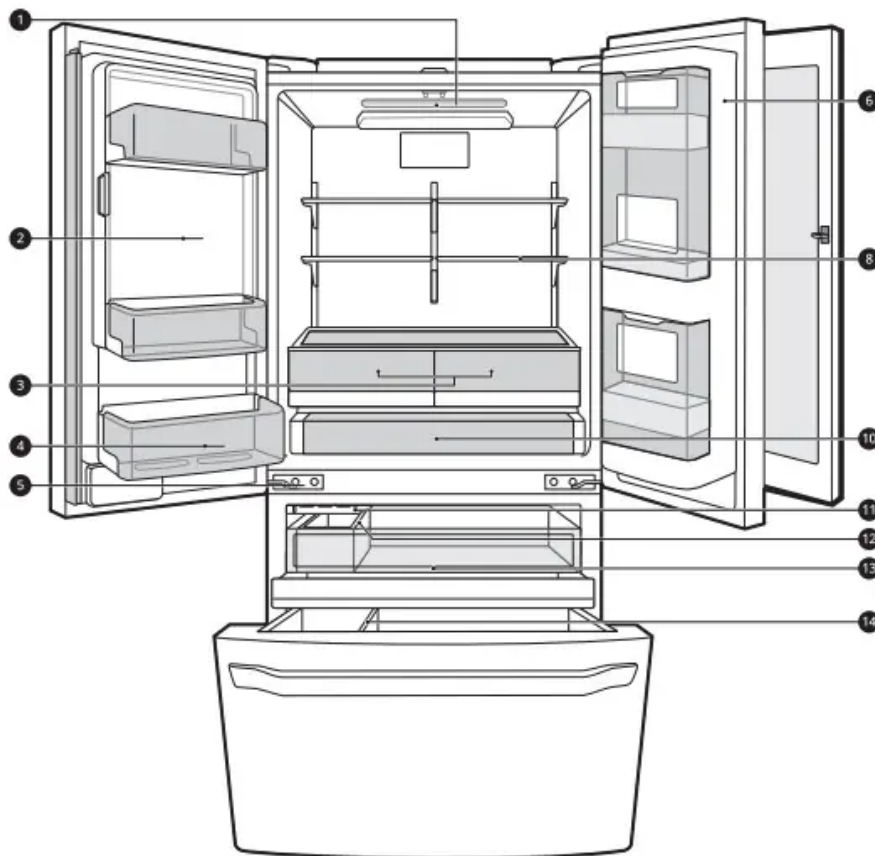

## 1. LED interior lamps

- Light up the inside of the refrigerator.

## 2. In-Door Icemaker (Refrigerator)

- This is where ice is automatically produced and stored.

### 3. Humidity Controlled Crisper

- Helps vegetables and fruit to stay crisp and controls humidity

### 4. Fixed Door Bin

- Store chilled food or drinks.

### 5. Auto-Closing Hinge

- The refrigerator doors and freezer drawers close automatically when pushed slightly. (The door only closes automatically when it is open at an angle of less than 30°.)

### 6. Door-in-Door Case

- A convenient storage area for frequently-used items that require easy access

### 7. Cheese & Butter and Condiment Bins

- Cheese & Butter and Condiment bins are specially designed for these items, making spreading butter and slicing cheese easier.

### 8. Adjustable Refrigerator Shelf

- The refrigerator shelves are adjustable to meet individual storage needs.

### 9. Modular Door Bin

- Interchangeable bins can be arranged to suit storage needs.

### 10. Glide'N'Serve

- Store food items at a different temperature than the regular refrigerator area.

### 11. Automatic Icemaker (Freezer)

- Dispenses ice automatically.

### 12. Ice Bin

- If a large amount of ice is needed, transfer the ice in the in-door ice bin to an ice storage bin in the freezer.

### 13. Pullout Drawer

- Provides extra storage within the freezer compartment.

### 14. Durabase and Durabase Divider

- Provides storage for large food items

## **Product Specifications**

The appearance and specifications listed in this manual may vary due to constant product improvements.

Electrical requirements: 115 V, 60 Hz

Min. / Max. water pressure: 20 - 120 psi (138 - 827 kPa)

<b>Model LRFDS3006*</b>	
Description	Standard-depth, Door-in-Door French door refrigerator, bottom freezer
Net weight	331 lb (150 kg)

<b>Model LRFVS3006*</b>	
Description	Standard-depth, InstaView Door-in-Door French door refrigerator, bottom freezer
Net weight	342 lb (155 kg)

<b>Model LRFXC2406*</b>	
Description	Counter-depth, French door refrigerator, bottom freezer
Net weight	276 lb (125 kg)

<b>Model LRFVC2406*</b>	
Description	Counter-depth, InstaView Door-in-Door French door refrigerator, bottom freezer
Net weight	311 lb (141 kg)

## INSTALLATION

### Before Installing

#### Installation Overview

Please read the following installation instructions first after purchasing this product or transporting it to another location.

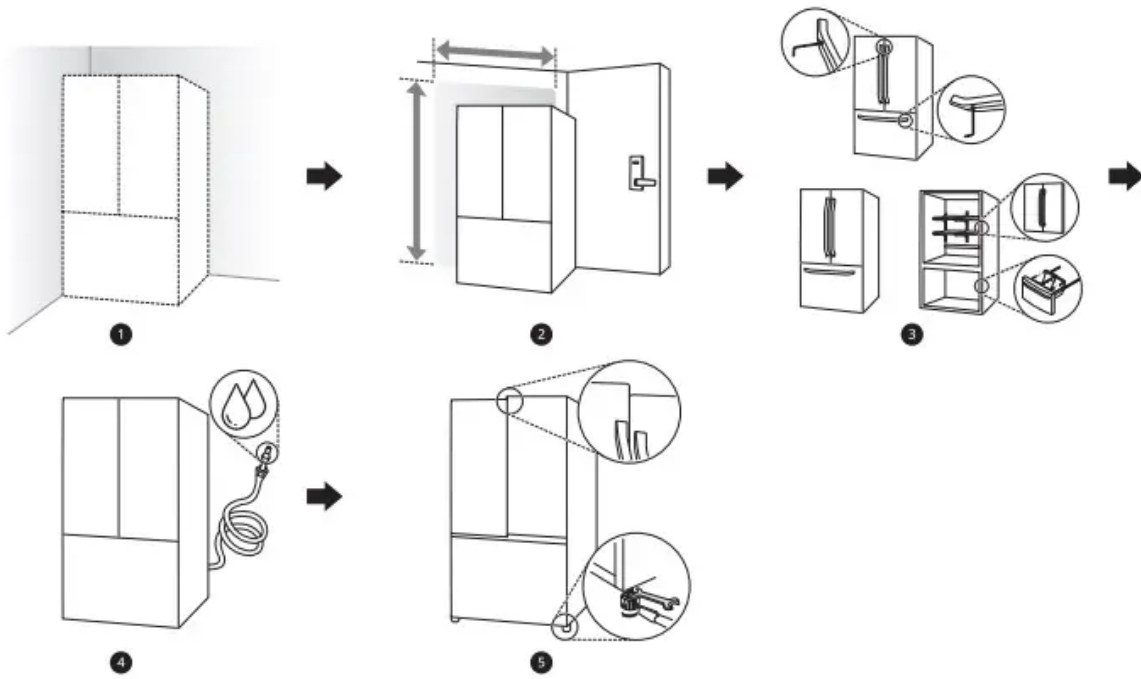

1. Unpacking the Refrigerator
2. Choosing the Proper Location
3. Disassembling/Assembling
4. Connecting the Water Line
5. Leveling and Door Alignment

### Unpacking the Refrigerator

#### WARNING

- Use two or more people to move and install the refrigerator. Failure to do so can result in back injury or other injury.
- The refrigerator is heavy. Protect the floor when moving the refrigerator for cleaning or service. Always pull the refrigerator straight out when moving it. Do not wiggle or walk the refrigerator when trying to move it, as floor damage could occur.
- Keep flammable materials and vapors, such as gasoline, away from the refrigerator. Failure to do so can result in fire, explosion, or death.

#### NOTE

- Remove tape and any temporary labels from your refrigerator before using. Do not remove any warning labels, the model and serial number label, or the Tech Sheet that is located under the front of the refrigerator.
- To remove any remaining tape or glue, rub the area briskly with your thumb. Tape or glue residue can also be easily removed by rubbing a small amount of liquid dish soap over the adhesive with your fingers. Wipe with warm water and dry.

- Do not use sharp instruments, rubbing alcohol, flammable fluids, or abrasive cleaners to remove tape or glue. These products can damage the surface of your refrigerator.
- Reinstall or adjust shelves as needed. Refrigerator shelves are installed in the shipping position. Reinstall shelves according to your individual storage needs.

## **Choosing the Proper Location**

### **Water**

- Water supply must be easily connected for the automatic icemaker.

### **Electricity**

- Use an individual, grounded outlet: 115 Volts, 60 Hz, AC, 15 Amps minimum.

### **Flooring**

- To avoid noise and vibration, the unit must be installed and leveled on a solidly constructed floor. If required, adjust the leveling legs to compensate for the unevenness of the floor.

### **Ambient Temperature**

- Install this appliance in an area where the temperature is between 55 °F (13 °C) and 110 °F (43 °C).
- If the temperature around the appliance is too low or high, cooling ability may be adversely affected.

### **Dimensions and Clearances**

- Check the dimensions of the appliance and the installation path to ensure there is sufficient room to move the refrigerator through doors or narrow openings.
- If an opening is too narrow to fit the refrigerator through, remove the refrigerator doors. See Removing/ Assembling the Doors and Drawers in this manual.
- The installation location chosen for the refrigerator should allow space behind the unit for connections and airflow and space in front to open the doors and drawers.
- Too small of a distance from adjacent items may result in lowered freezing capability and increased electricity consumption charges. Allow at least 24 inches (610 mm) in front of the refrigerator to open the doors, and at least 2 inches (50.8 mm) between the back of the refrigerator and the wall.

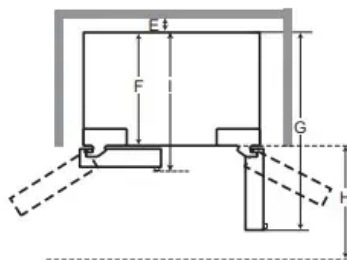
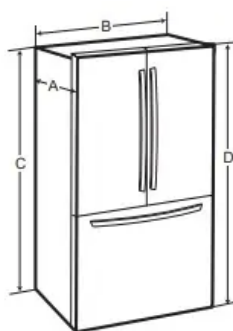

-	Dimension/Clearance	LRFVS3006*	LRFVC2406*
		LRFDS3006*	LRFXC2406*
A	Depth without Handle	34 1/8" (866 mm)	28 1/4" (718 mm)
B	Width	35 3/4" (908 mm)	35 3/4" (908 mm)
C	Height to Top of Case	68 7/8" (1750 mm)	68 7/8" (1750 mm)
D	Height to Top of Hinge	70 1/4" (1785 mm)	70 1/4" (1785 mm)
E	Back Clearance	2" (50 mm)	2" (50 mm)
F	Depth without Door	29 7/8" (758 mm)	24" (610 mm)
G	Depth (Total with Door Open 90°)	42 5/8" (1231 mm)	42 5/8" (1083 mm)
H	Front Clearance	24" (610 mm)	24" (610 mm)
I	Depth with Handle	36 5/8" (929 mm)	30 3/4" (781 mm)

## Connecting the Water Line

### Before Beginning

This water line installation is not covered by the refrigerator warranty. Follow these instructions carefully to minimize the risk of expensive water damage.

If necessary, call a qualified plumber to correct water hammer before installing the water supply line to the refrigerator. Water banging in the pipes, or water hammer in residential plumbing can cause damage to refrigerator parts and lead to water leakage or flooding.

- Turn the icemaker OFF if the refrigerator will be used before the water line is connected.
- Do not install the icemaker tubing in areas where the ambient temperatures fall below freezing.

### Water Pressure

You will need a cold water supply.

<b>Water Pressure</b>	
models with water filter	20 - 120 psi (138 - 827 kPa)
where reverse osmosis water filtration system is connected to a cold water supply	40 - 60 psi minimum to reverse osmosis system (2.8 kgf/cm <sup>2</sup> - 4.2 kgf/cm <sup>2</sup> , or less than 2 - 3 seconds to fill a cup of 7 oz capacity)

If the water pressure from the reverse osmosis system is less than 20 psi or 138 kPa or 1.4 kgf/cm<sup>2</sup> (takes more than 4 seconds to fill a cup of 7 oz or 198 cc capacity):

- Check to see if the sediment filter in the reverse osmosis system is blocked. Replace the filter if necessary.
- Allow the storage tank on the reverse osmosis system to refill after heavy usage.
- If the water pressure remains low, call a licensed, qualified plumber.
- All installations must be in accordance with local plumbing code requirements.

### **Supplies Needed**

- Copper or PEX Tubing, ¼ in. outer diameter, to connect the refrigerator to the water supply. Be sure both ends of the tubing are cut square. To determine how much tubing you need, measure the distance from the water valve on the back of the refrigerator to the water supply pipe. Then, add 8 feet (2.4 m). Be sure there is sufficient extra tubing (about 8 feet [2.4 m] coiled into 3 turns of about 10 in. [25 cm] diameter) to allow the refrigerator to move out from the wall after installation.
- Power drill.
- ½ in. or adjustable wrench.
- Flat-blade and Phillips-head screwdrivers.
- Two ¼ in. outer diameter compression nuts and 2 ferrules (sleeves) to connect the copper tubing to the shutoff valve and the refrigerator water valve.

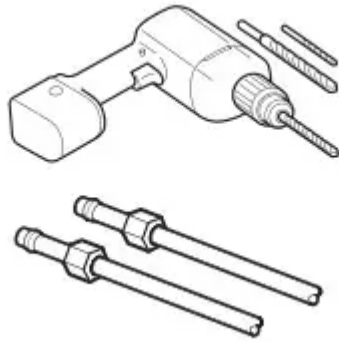

- If your existing copper water line has a flared fitting at the end, purchase an adapter (available at plumbing supply stores) to connect the water line to the refrigerator OR cut off the flared fitting with a tube cutter and then use a compression fitting.

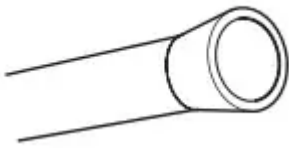

- Shutoff valve to connect to the cold water line. The shutoff valve should have a water inlet with a minimum inside diameter of 5/32 in. at the point of connection to the COLD WATER LINE. Saddle-type shutoff valves are included in many water supply kits. Before purchasing, make sure a saddle-type valve complies with your local plumbing codes.

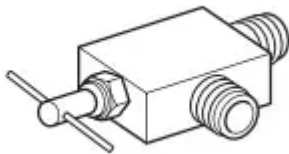

## Water Line Installation Instructions

1 Shut off the main water supply.

- Turn on the nearest faucet to relieve the pressure on the line.

2 Choose the valve location.

- Choose a location for the valve that is easily accessible. It is best to connect into the side of a vertical water pipe. When it is necessary to connect into a horizontal water pipe, make the connection to the top or side, rather than at the bottom, to avoid drawing off any sediment from the water pipe.

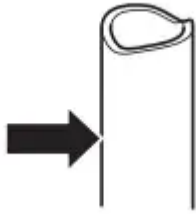

### 3 Drill the hole for the valve.

- Drill a ¼ in. hole in the water pipe using a sharp bit. Remove any burrs resulting from drilling the hole in the pipe. Be careful not to allow water to drain into the drill. Failure to drill a ¼ in. hole may result in reduced ice production or smaller cubes.

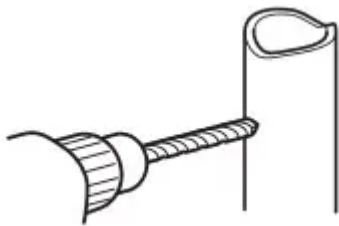

### 4 Fasten the shutoff valve.

- Fasten the shutoff valve to the cold water pipe with the pipe clamp.

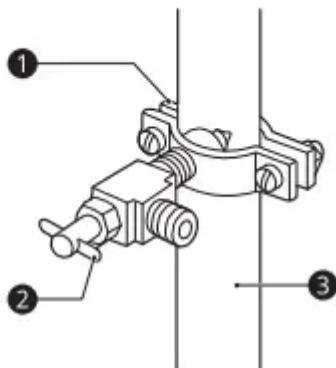

- ❶ Pipe Clamp
- ❷ Saddle-Type Shutoff Valve
- ❸ Vertical Cold Water Pipe

### 5 Tighten the pipe clamp.

- Tighten the clamp screws until the sealing washer begins to swell.

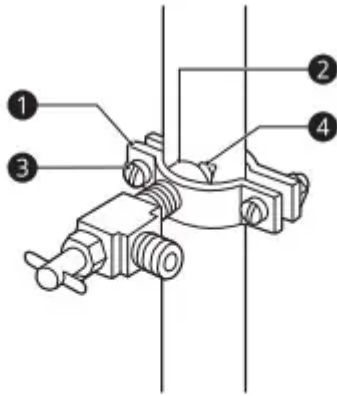

- ❶ Pipe Clamp
- ❷ Inlet End
- ❸ Clamp Screw
- ❹ Washer

6 Route the tubing.

- Route the tubing between the cold water line and the refrigerator. Route the tubing through a hole drilled in the wall or floor (behind the refrigerator or adjacent base cabinet) as close to the wall as possible.

7 Connect the tubing to the valve.

- Place the compression nut and ferrule (sleeve) for copper tubing onto the end of the tubing and connect it to the shutoff valve. Make sure the tubing is fully inserted into the valve. Tighten the compression nut securely.

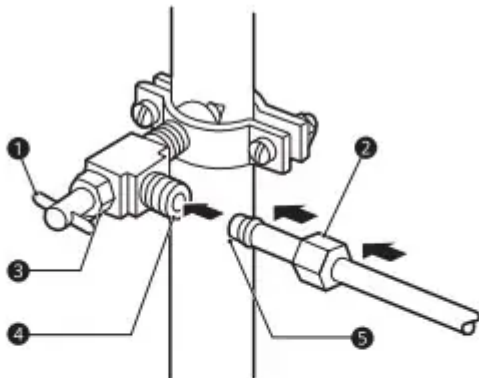

- ❶ Saddle-Type Shutoff Valve
- ❷ Compression Nut
- ❸ Packing Nut
- ❹ Outlet Valve
- ❺ Ferrule (sleeve)

8 Flush out the tubing.

- Turn the main water supply on and flush out the tubing until the water is clear. Shut the water off at the water valve after about one quart of water has been flushed through the tubing.



9 Connect the tubing to the refrigerator.

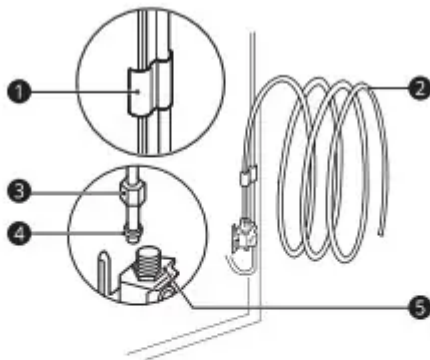

- ❶ Tubing Clamp
- ❷ ¼ in. Tubing
- ❸ ¼ in. Compression Nut
- ❹ Ferrule (sleeve)
- ❺ Refrigerator Connection

10 Turn the water on at the shutoff valve.

- Tighten any connections that leak.

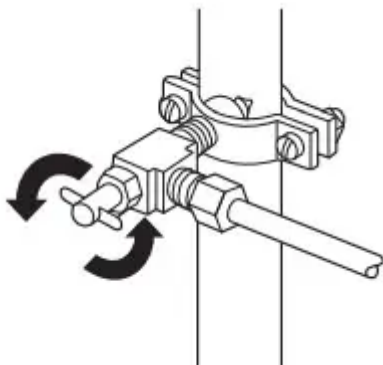

## Leveling and Door Alignment

### Leveling

The refrigerator has two front leveling legs. Adjust the legs to alter the tilt from front-to-back or side to side. If the refrigerator seems unsteady, or the doors do not close easily, adjust the refrigerator's tilt using the instructions below:

1. Turn the leveling leg to the left to raise that side of the refrigerator or to the right to lower it. It may take several turns of the leveling leg to adjust the tilt of the refrigerator.

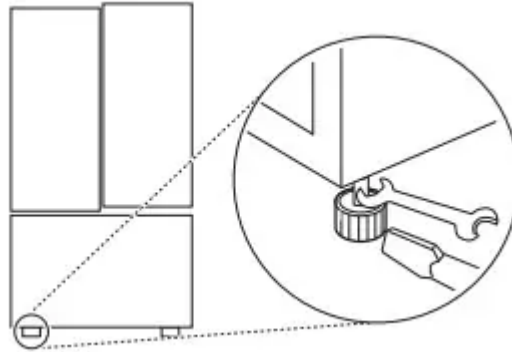

2. Open both doors and check to make sure that they close easily. If the doors do not close easily, tilt the refrigerator slightly more to the rear by turning both leveling legs to the left. It may take several more turns, and be sure to turn both leveling legs the same amount.

### Door Alignment (Standard Door Model)

- Both the left and right refrigerator doors have an adjustable nut, located on the bottom hinge, to raise and lower them to align properly.
- If the space between the doors is uneven even after the door bins are filled, follow the instructions below to align the doors evenly
- Use the wrench (included with the owner's manual) to turn the nut in the door hinge to adjust the height. Turn the nut to the right to raise the door or to the left to lower it.

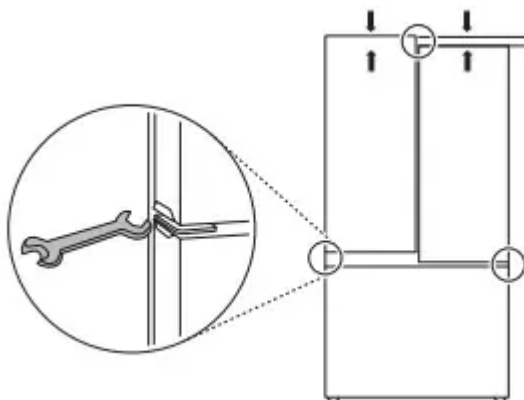

### Door Alignment (Door-in-Door Model)

#### *Left Refrigerator Door*

The left refrigerator door has an adjustable nut, located on the bottom hinge, to raise and lower the door for proper alignment.

If the space between the doors is uneven, follow the instructions below to align the left door:

Use the wrench (included with the owner's manual) to turn the nut in the door hinge to adjust the height. Turn the nut to the right to raise the door or to the left to lower it.

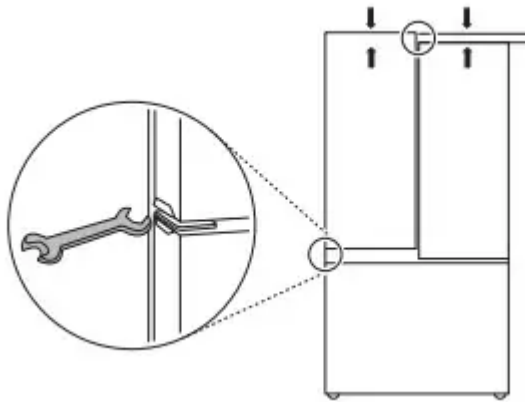

### *Right Refrigerator Door*

The right refrigerator door does not have an adjustable nut. If the space between the doors is uneven, follow the instructions below to align the right door:

1. With one hand, lift up both the inner and outer door sections of the right door to raise them at the middle hinge. (It may be easier to lift it with the doors open.)
2. With the other hand, use pliers to insert the snap ring on the middle hinge of the inner door section as shown. Do not insert the ring on the hinge of the outer door section.
3. Insert additional snap rings until the right door is aligned. (Two snap rings are provided with the unit.)

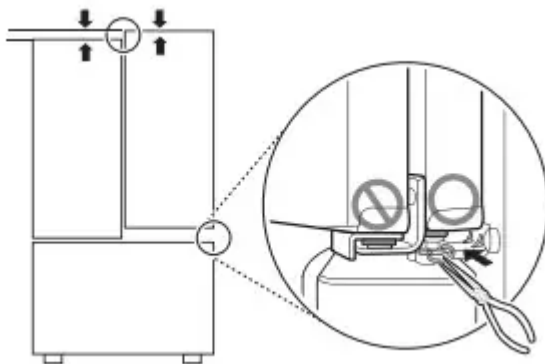

### **Turning on the Power**

- After installing, plug the refrigerator's power cord into a 3-prong grounded outlet and push the refrigerator into the final position.

### **Position the Refrigerator**

- Arrange the coil of tubing so that it does not vibrate against the back of the refrigerator or against the wall. Push the refrigerator back to the wall.

## Start the Icemaker

- If the water line is connected, set the icemaker power switch to the ON position.
- The icemaker will not begin to operate until it reaches its operating temperature of 15 °F (–9 °C) or below. It will then begin operation automatically if the icemaker power switch is in the ON (I) position.

## OPERATION

### Control Panel

Depending on the model, some of the following functions may not be available. The actual control panel may differ from model to model.

### Control Panel Features

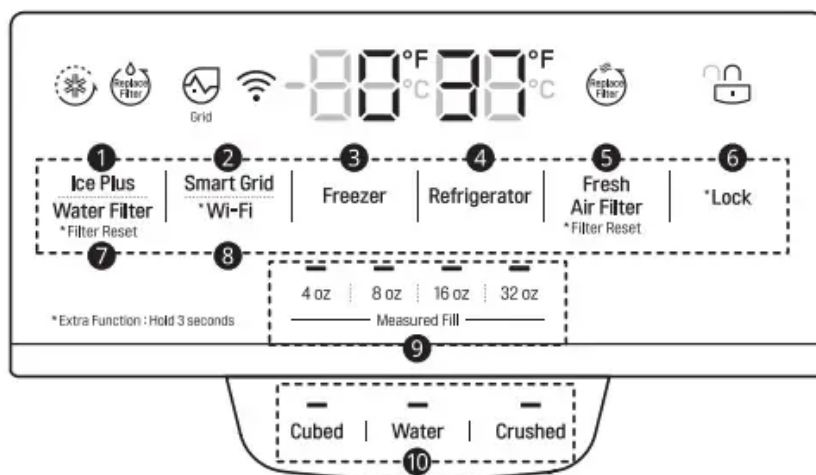

#### 1. Ice Plus

- This function increases both ice making and freezing capabilities.
- Press the Ice Plus button to illuminate the icon and activate the function for 24 hours. The function automatically shuts off after 24 hours. Stop the function manually by pressing the button once more.

#### 2. Smart Grid

- Press the Smart Grid button to turn the function On/Off. When the function is on, the icon illuminates. The function automatically turns on when the refrigerator is connected to the Wi-Fi network.
- When the refrigerator is responding to a Demand Response (DR) message from the electric company, the Grid text illuminates.

### 3. Freezer

- Indicates the set temperature of the freezer compartment in Celsius (°C) or Fahrenheit (°F). The default freezer temperature is 0°F (-18 °C). Press the Freezer button repeatedly to select a new set temperature from - 6 °F to 8 °F (-21 °C to -13 °C).

### 4. Refrigerator

- Indicates the set temperature of the refrigerator compartment in Celsius (°C) or Fahrenheit (°F). The default refrigerator temperature is 37 °F (3 °C). Press the Refrigerator button repeatedly to select a new set temperature from 33 °F to 46 °F (1 °C to 8 °C).

### 5. Fresh Air Filter

- The Fresh Air Filter helps remove odors from the refrigerator.

### 6. Lock

The lock function disables every other button on the display.

- When power is initially connected to the refrigerator, the lock function is off.
- To lock the control panel buttons, press and hold the Lock button until the  icon appears in the display and the function is activated.
- To disable the function, press and hold the Lock button for approximately three seconds.

### 7. Water Filter

- Replace the water filter when the  icon turns on. After replacing the water filter, press and hold the Water Filter button for three seconds to turn the icon light off. Replace the water filter approximately every six months.

### 8. Wi-Fi

- The Wi-Fi button, when used with the LG SmartThinQ app, allows the refrigerator to connect to a home Wi-Fi network. Refer to Smart Functions for information on the initial setup of the application.
- The  icon shows the status of the refrigerator's network connection. The icon illuminates when the refrigerator is connected to the Wi-Fi network.
- Press and hold the Wi-Fi button for 3 seconds to connect to the network. The icon blinks while the connection is being made, then turns on once the connection is successfully made.

### 9. Measured Fill

- The measured fill function dispenses premeasured amounts of water automatically.

## 10. Water & Ice Type

- Select the desired dispenser mode from the buttons on the dispenser control panel. Press the dispenser switch with a glass or other container to dispense cubed ice, water or crushed ice.

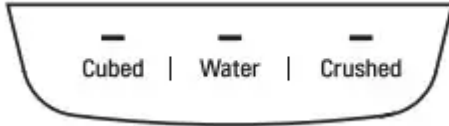

## Sabbath Mode

- Sabbath mode is used on the Jewish Sabbath and holidays.
- To activate the Sabbath mode:
  - To turn Sabbath mode on, touch the display to activate it, then press and hold the Freezer and Wi-Fi buttons for 3 seconds until sb appears in the display.
  - Sabbath mode automatically turns off after 96 hours.
  - To turn Sabbath mode off manually, press and hold the Freezer and Wi-Fi buttons for 3 seconds.
  - Once turned on, Sabbath mode is maintained even after a power outage.
  - Selecting Sabbath mode automatically turns off the Alarm functions. The dispenser and InstaView are disabled in Sabbath Mode.

## Ice and Water Dispenser

### Using the Ice and Water Dispenser

- Select the desired dispenser mode from the buttons on the dispenser control panel.
- Press the dispenser paddle 1 with a glass or other container to dispense cubed ice, water or crushed ice.

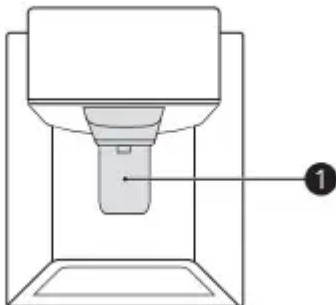

### Using the Measured Fill

The Measured Fill function dispenses premeasured amounts of water automatically.

1. Select the desired amount from the Measured Fill buttons on the dispenser control panel.

2. Press the dispenser switch with a container.
3. To stop the measured fill, release the dispenser switch.

### Locking the Ice and Water Dispenser

- Press and hold the Lock button for three seconds to lock the dispenser and all the control panel functions. Follow the same instructions to unlock.

### Ice Compartment

Keep the ice compartment door closed tightly. If the ice compartment door is not closed tightly, the cold air in the ice bin will freeze food in the refrigerator compartment. This could also cause the icemaker to stop producing ice.

### In-Door Ice Bin

- The icemaker stops producing ice when the indoor ice bin is full. To make room for additional ice, empty the ice bin into the extra ice bin in the freezer compartment. During use, the ice may stack unevenly in the bin, causing the icemaker to misread the number of ice cubes and stop producing ice. Shaking the ice bin to level the ice within it can reduce this problem.
- If the icemaker is turned OFF for an extended period of time, the ice compartment will gradually warm up to the temperature of the refrigerator compartment. To prevent ice cubes from melting and leaking from the dispenser, ALWAYS empty the ice bin when the icemaker is turned OFF for more than a few hours.
- The ice passage may become blocked with frost if only crushed ice is used. Remove the frost that accumulates by removing the ice bin and clearing the passage with a rubber spatula. Dispensing cubed ice can also help prevent frost buildup.

### Detaching the In-Door Ice Bin

1. Gently pull the handle to open the ice compartment.

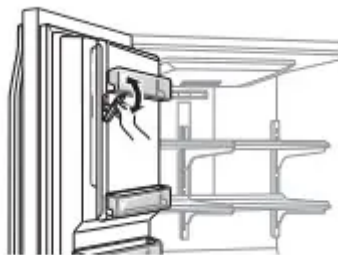

2. To remove the in-door ice bin, grip the front handle, slightly lift the lower part, and slowly

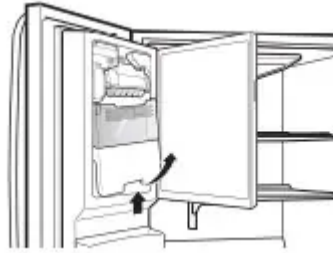

pull out the bin as shown.

## MAINTENANCE

### Cleaning

#### General Cleaning Tips

- Both the refrigerator and freezer sections defrost automatically; however, clean both sections once a month to prevent odors.
- Wipe up spills immediately.
- Unplug the refrigerator or disconnect power before cleaning.
- Remove all removable parts, such as shelves.
- Use a clean sponge or soft cloth and a mild detergent in warm water. Do not use abrasive or harsh cleaners.
- Hand wash, rinse and dry all surfaces thoroughly

#### Exterior

- Waxing external painted metal surfaces helps provide rust protection. Do not wax plastic parts. Wax painted metal surfaces at least twice a year using appliance wax (or auto paste wax). Apply wax with a clean, soft cloth.
- For products with black stainless steel exterior, spray glass cleaner on a clean, microfiber cloth and rub in direction of grain. Do not spray glass cleaner directly at the display panel. Do not use harsh or abrasive cleaners.
- For products with a standard stainless steel exterior, use a damp microfiber cloth and rub in the direction of the grain. Dry with a paper towel to avoid streaks. For stubborn stains and fingerprints, use a few drops of liquid dish soap in water, and rinse with hot water before drying. Do not use abrasive or harsh cleaners.

#### Inside Walls

- Allow freezer to warm up so the cloth will not stick.

To help remove odors, wash the inside of the refrigerator with a mixture of baking soda and warm water. Mix 2 tablespoons of baking soda to 1 quart of water (26 g soda to 1 liter water.) Be sure the baking soda is completely dissolved so it does not scratch the surfaces of the refrigerator.

## Door Liners and Gaskets

- Use a clean sponge or soft cloth and a mild detergent in warm water. Do not use cleaning waxes, concentrated detergents, bleaches, or cleaners containing petroleum on plastic refrigerator parts.

## Plastic Parts (Covers and Panels)

- Use a clean sponge or soft cloth and a mild detergent in warm water. Do not use glass cleaners, abrasive cleansers, or flammable fluids. These can scratch or damage the material.

## Condenser Coils

- Use a vacuum cleaner with a brush or crevice attachment to clean the condenser cover and vents. Do not remove the panel covering the condenser coil area.

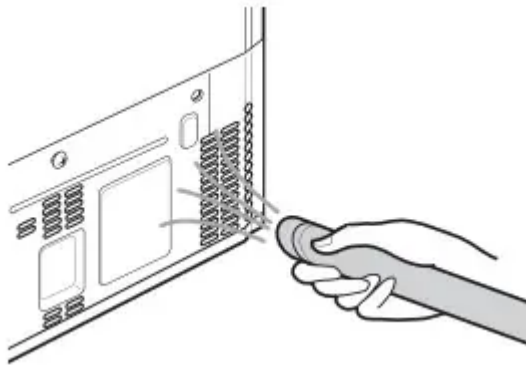

# TROUBLESHOOTING

## FAQs

### Frequently Asked Questions

Q: What are the best temperature settings for my refrigerator and freezer?

A: The default setting for the refrigerator is 37° Fahrenheit (3° Celsius). The default setting for the freezer is 0° Fahrenheit (-18° Celsius). Adjust these settings as necessary to keep food at desired temperatures. Milk should be cold when stored on the inner shelf of the refrigerator. Ice cream should be firm and ice cubes should not melt in the freezer. To switch the display from Fahrenheit to Celsius, press and hold the Freezer and Refrigerator buttons until you hear a beep and the settings in the display change.

Q: How do I set the refrigerator and freezer temperatures?

A: Continually press the Refrigerator or Freezer button on the control panel until the desired temperature appears. The numbers will cycle from highest to lowest and then return to the highest again with continuous pressing.

Q: Why do I hear a buzzing noise from my refrigerator periodically?

A: This may happen if you do not have a water source attached to your refrigerator and the icemaker is turned on. If you do not have a water source attached to the back of the refrigerator you should turn the icemaker off.

Q: Why does the icemaker tray look crooked?

A: This is a normal part of the icemaker cycle. The icemaker tray may appear level or with a slight tilt. The change in position is to assist in the freezing process.

Q: My refrigerator is powered on and the controls are working, but it's not cooling and the display shows "OFF" (see below). What is wrong?

A: The refrigerator is in Display Mode. The Display Mode disables all cooling in the refrigerator and freezer sections to conserve energy while on display in a retail store. When activated, OFF is displayed on the control panel and the display remains on for 20 seconds. With either refrigerator door opened, press the Ice Plus button 3 times consecutively while pressing the Refrigerator button. The control panel beeps and the temperature settings display to confirm that Display Mode is deactivated. Use the same procedure to activate Display Mode.



## Before Calling for Service

Review this section before calling for service; doing so will save you both time and money.

### Cooling

Refrigerator and Freezer section are not cooling.

- The refrigerator control is set to OFF (some models).
  - Turn the control ON. Refer to the Setting the Controls section for proper temperature settings.
- Refrigerator is set to Demo Mode.
  - Demo Mode allows the lights and control display to work normally while disabling cooling, to save energy while the refrigerator is on the showroom floor. See the FAQs section of this manual for instructions on how to disable Demo Mode.
- Refrigerator is in the defrost cycle.
  - During the defrost cycle, the temperature of each compartment may rise slightly. Wait 30 minutes and confirm the proper temperature has been restored once the defrost cycle has completed.

- Refrigerator was recently installed.
  - It may take up to 24 hours for each compartment to reach the desired temperature.
- Refrigerator was recently relocated.
  - If the refrigerator was stored for a long period of time or moved on its side, it is necessary for the refrigerator to stand upright for 24 hours before connecting it to power.

Cooling system runs too much.

- Refrigerator is replacing an older model.
  - Modern refrigerators require more operating time but use less energy due to more efficient technology.
- Refrigerator was recently plugged in or power restored.
  - The refrigerator will take up to 24 hours to cool completely
- The door is opened often or a large amount of food / hot food was added.
  - Adding food and opening the door warms the refrigerator, requiring the compressor to run longer in order to cool the refrigerator back down. In order to conserve energy, try to get everything you need out of the refrigerator at once, keep food organized so it is easy to find, and close the door as soon as the food is removed. (Refer to the Food Storage Guide.)
- Doors are not closed completely.
  - Firmly push the doors shut. If they will not shut all the way, the "Doors will not close correctly or pop open" section in Troubleshooting.
- Refrigerator is installed in a hot location.
  - The compressor will run longer under warm conditions. At normal room temperatures (70 °F or 21 °C) expect your compressor to run about 40 % to 80 % of the time. Under warmer conditions, expect it to run even more often. The refrigerator should not be operated above 110 °F (43 °C).
- Condenser / back cover is clogged.
  - Use a vacuum cleaner with an attachment to clean the condenser cover and vents. Do not remove the panel covering the condenser coil area.

Interior moisture buildup

- Doors are opened often or for long periods of time.
  - When the doors are opened often or for long periods of time, warm, humid air enters the compartment. This raises the temperature and moisture level within

the compartment. To lessen the effect, reduce the frequency and duration of door openings.

- Doors are not closed correctly.
  - See the "Doors will not close correctly or pop open" section
- Weather is humid.
  - Humid weather allows additional moisture to enter the compartments when the doors are opened leading to condensation or frost. Maintaining a reasonable level of humidity in the home will help to control the amount of moisture that can enter the compartments.
- Defrost cycle recently completed.
  - During the defrost cycle, the temperature of each compartment may rise slightly and condensation may form on the back wall. Wait 30 minutes and confirm that the proper temperature has been restored once the defrost cycle has completed.
- Food is not packaged correctly.
  - Food stored uncovered or unwrapped, and damp containers can lead to moisture accumulation within each compartment. Wipe all containers dry and store food in sealed packaging to prevent condensation and frost.

Food is freezing in the refrigerator compartment.

- Food with high water content was placed near an air vent.
  - Rearrange items with high water content away from air vents.
- Refrigerator temperature control is set incorrectly.
  - If the temperature is too cold, adjust the control one increment at a time and wait for the temperature to stabilize. Refer to the Control Panel section for more information.
- Refrigerator is installed in a cold location.
  - When the refrigerator is operated in temperature below 41 °F (5 °C), food can freeze in the refrigerator compartment. The refrigerator should not be operated in temperature below 55 °F (13 °C).

Refrigerator or Freezer section is too warm.

- Refrigerator was recently installed.
  - It may take up to 24 hours for each compartment to reach the desired temperature.

- The air vents are blocked. Cold air circulates from the freezer to the fresh food section and back again through air vents in the wall dividing the two sections.
  - Locate air vents by using your hand to sense airflow and move all packages that block vents and restrict airflow. Rearrange items to allow air to flow throughout the compartment.
- Doors are opened often or for long periods of time.
  - When the doors are opened often or for long periods of time, warm, humid air enters the compartment. This raises the temperature and moisture level within the compartment. To lessen the effect, reduce the frequency and duration of door openings.
- Unit is installed in a hot location.
  - The refrigerator should not be operated in temperatures above 110 °F (43 °C).
- A large amount of food or hot food was added to either compartment.
  - Adding food warms the compartment requiring the cooling system to run. Allowing hot food to cool to room temperature before putting it in the refrigerator will reduce this effect.
- Doors are not closed correctly.
  - See the "Doors will not close correctly or pop open" section in the Troubleshooting.
- Temperature control is not set correctly.
  - If the temperature is too warm, adjust the control one increment at a time and wait for the temperature to stabilize.
- Defrost cycle has recently completed.
  - During the defrost cycle, the temperature of each compartment may rise slightly and condensation may form on the back wall. Wait 30 minutes and confirm the proper temperature has been restored once the defrost cycle has completed.

Refrigerator or Freezer section is too cold.

- Incorrect temperature control settings.
  - If the temperature is too cold, adjust the control one increment at a time and wait for the temperature to stabilize. Refer to the Control Panel for more information.

Frost or ice crystals form on frozen food (inside of sealed package).

- Condensation from food with a high water content has frozen inside of the food package.
  - This is normal for food items with a high water content.
- Food has been left in the freezer for a long period of time.
  - Do not store food items with high water content in the freezer for a long period of time.

Frost or ice crystals form on frozen food (outside of package).

- Door is opened frequently or for long periods of time.
  - When the doors are opened often or for long periods of time, warm, humid air enters the compartment. This raises the temperature and moisture level within the compartment. Increased moisture will lead to frost and condensation. To lessen the effect, reduce the frequency and duration of door openings.
- Door is not closing properly.
  - Refer to the "Doors will not close correctly or pop open" section in the Troubleshooting.

## **Ice & Water**

Icemaker is not making enough ice.

- Demand exceeds ice storage capacity.
  - The icemaker will produce approximately 70-184 cubes in a 24 hour period.
- House water supply is not connected, valve is not turned on fully, or valve is clogged.
  - Connect the refrigerator to a cold water supply with adequate pressure and turn the water shutoff valve fully open. If the problem persists, it may be necessary to contact a plumber.
- Water filter has been exhausted.
  - Replacing the water filter is recommended: Approximately every six months. When the water filter indicator turns on. When the water dispenser output decreases. When the ice cubes are smaller than normal.
- Low house water supply pressure.
  - The water pressure must be between 20 and 120 psi on models without a water filter and between 40 and 120 psi on models with a water filter. If the problem persists, it may be necessary to contact a plumber.

- Reverse osmosis filtration system is used.
  - Reverse osmosis filtration systems can reduce the water pressure below the minimum amount and result in icemaker issues. (Refer to the Connecting the Water Line section.)
- Tubing connecting refrigerator to house supply valve is kinked.
  - The tubing can kink when the refrigerator is moved during installation or cleaning resulting in reduced water flow. Straighten or repair the water supply line and arrange it to prevent future kinks.
- Doors are opened often or for long periods of time.
  - If the doors of the unit are opened often, ambient air will warm the refrigerator which will prevent the unit from maintaining the set temperature. Lowering the refrigerator temperature can help, as well as not opening the doors as frequently.
- Doors are not closed completely.
  - If the doors are not properly closed, ice production will be affected. See the "Doors will not close correctly or pop open" section in Parts & Features Troubleshooting for more information.
- The temperature setting for the freezer is too warm.
  - The recommended temperature for the freezer compartment for normal ice production is 0°F. If the freezer temperature is warmer, ice production will be affected.

#### Icemaker is not making ice

- Refrigerator was recently installed or icemaker recently connected.
  - It may take up to 24 hours for each compartment to reach the desired temperature and for the icemaker to begin making ice.
- Icemaker is not turned on.
  - Locate the icemaker ON/OFF and confirm that it is turned on.
- The ice detecting sensor is obstructed.
  - Foreign substances or frost on the ice-detecting sensor can interrupt ice production. Make sure that the sensor area is clean at all times for proper operation.

- The refrigerator is not connected to a water supply or the supply shutoff valve is not turned on.
  - Connect the refrigerator to the water supply and turn the water shutoff valve fully open
- Icemaker shutoff (arm or sensor) obstructed.
  - If your icemaker is equipped with an ice shutoff arm, make sure that the arm moves freely. If your icemaker is equipped with the electronic ice shutoff sensor, make sure that there is a clear path between the two sensors.
- Reverse osmosis water filtration system is connected to your cold water supply.
  - Reverse osmosis filtration systems can reduce the water pressure below the minimum amount and result in icemaker issues. (Refer to the Connecting the Water Line section.)

Ice has bad taste or odor.

- Water supply contains minerals such as sulfur.
  - A water filter may need to be installed to eliminate taste and odor problems. NOTE: In some cases, a filter may not help. It may not be possible to remove all minerals/odor/taste in all water supplies.
- Icemaker was recently installed.
  - Ice that has been stored for too long will shrink, become cloudy, and may develop a stale taste. Throw away old ice and make a new supply.
- The food has not been stored properly in either compartment.
  - Rewrap the food. Odors may migrate to the ice if food is not wrapped properly.
- The interior of the refrigerator needs to be cleaned.
  - See the Maintenance section for more information.
- The ice storage bin needs to be cleaned.
  - Empty and wash the bin (discard old cubes). Make sure that the bin is completely dry before reinstalling it

Icemaker is making too much ice.

- Icemaker shutoff (arm/ sensor) is obstructed.
  - Empty the ice bin. If your icemaker is equipped with an ice shutoff arm, make sure that the arm moves freely. If your icemaker is equipped with the electronic ice shutoff sensor, make sure that there is a clear path between the two sensors. Reinstall the ice bin and wait 24 hours to confirm proper operation.

## Ice is not dispensing

- Unable to hear the sound of ice coming out?
  - In the control panel, select the modes for cubed ice and crushed ice alternately to dispense the ice.
- Doors are not closed completely.
  - Ice will not dispense if any of the refrigerator doors are left open.
- Infrequent use of the dispenser.
  - Infrequent use of the ice dispenser will cause the cubes to stick together over time, which will prevent them from properly dispensing. Check the ice bin for ice cubes clumping/ sticking together. If they are, break up the ice cubes to allow for proper operation.
- The delivery chute is clogged with frost or ice fragments.
  - Eliminate the frost or ice fragments by removing the ice bin and clearing the chute with a plastic utensil. Dispensing cubed ice can also help prevent frost or ice fragment buildup
- The dispenser display is locked.
  - Press and hold the Lock button for three seconds to unlock the control panel and dispenser.
- Ice bin is empty.
  - It may take up to 24 hours for each compartment to reach the desired temperature and for the icemaker to begin making ice. Make sure that the shutoff (arm/sensor) is not obstructed. Once the ice supply in the bin has been completely exhausted, it may take up to 90 minutes before additional ice is available, and approximately 24 hours to completely refill the bin.

## Water is dispensing slowly.

- Water filter has been exhausted.
  - Replacing the water filter is recommended: Approximately every six months. When the water filter indicator turns on. When the water dispenser output decreases. When the ice cubes are smaller than normal.
- Reverse osmosis filtration system is used.
  - Reverse osmosis filtration systems can reduce the water pressure below the minimum amount and result in icemaker issues. If the problem persists, it may be necessary to contact a plumber.

- Low house water supply pressure.
  - The water pressure must be between 20 and 120 psi on models without a water filter and between 40 and 120 psi on models with a water filter. If the problem persists, it may be necessary to contact a plumber.

Water is not dispensing.

- New installation or water line recently connected.
  - Dispense 2.5 gallons of water (flush for approximately 5 minutes) to remove trapped air and contaminants from the system. Do not dispense the entire 2.5 gallon amount continuously. Depress and release the dispenser pad for cycles of 30 seconds ON and 60 seconds OFF.
- The dispenser panel is locked.
  - Press and hold the Lock button for three seconds to unlock the control panel and dispenser.
- The dispenser is not set for water dispensing.
  - The dispenser can be set for ice or water. Make certain that the control panel is set for the proper operation. Press the Water button on the control panel to dispense water.
- Refrigerator or freezer doors are not closed properly.
  - Water will not dispense if any of the refrigerator doors are left open.
- Water filter has been recently removed or replaced.
  - After the water filter is replaced, dispense 2.5 gallons of water (flush for approximately five minutes) to remove trapped air and contaminants from the system. Do not dispense the entire 2.5 gallon amount continuously. Depress and release the dispenser pad for cycles of 30 seconds ON and 60 seconds OFF.
- Tubing connecting refrigerator to house supply valve is kinked.
  - The tubing can kink when the refrigerator is moved during installation or cleaning. Resulting in reduced water flow. Straighten or repair the water supply line and arrange it to prevent future kinks.
- The house water supply is not connected, the valve is not turned on fully, or the valve is clogged.
  - Connect the refrigerator to the water supply and turn the water shutoff valve fully open. If the problem persists, it may be necessary to contact a plumber

Dispensing warm water.

- Refrigerator was recently installed.
  - Allow 24 hours after installation for the water storage tank to cool completely.
- The water dispenser has been used recently and the storage tank was exhausted.
  - Depending on your specific model, the water storage capacity will range from approximately 20 to 30 oz.
- Dispenser has not been used for several hours.
  - If the dispenser has not been used for several hours, the first glass dispensed may be warm. Discard the first 10oz.
- Refrigerator is connected to the hot water supply.
  - Make sure that the refrigerator is connected to a cold water pipe.

**WARNING:** Connecting the refrigerator to a hot water line may damage the icemaker.

Water has bad taste or odor.

- Water supply contains minerals such as sulfur.
  - A water filter may need to be installed to eliminate taste and odor problems
- Water filter has been exhausted.
  - Replacing the water filter is recommended: Approximately every six months. When the water filter indicator turns on. When the water dispenser output decreases. When the ice cubes are smaller than normal.
- Refrigerator was recently installed.
  - Dispense 2.5 gallons of water (flush for approximately 5 minutes) to remove trapped air and contaminants from the system. Do not dispense the entire 2.5 gallon amount continuously. Depress and release the dispenser pad for cycles of 30 seconds ON and 60 seconds OFF.

## **Parts & Features**

Doors will not close correctly or pop open

- Food packages are blocking the door open.
  - Rearrange food containers to clear the door and door shelves.
- Ice bin, crisper cover, pans, shelves, door bins, or baskets are out of position.
  - Push bins all the way in and put crisper cover, pans, shelves and baskets into their correct positions. See the Operation section for more information.

- The doors were removed during product installation and not properly replaced.
  - Remove and replace the doors according to the Removing and Replacing Refrigerator Handles and Doors section.
- Refrigerator is not leveled properly.
  - See Door Alignment in the Refrigeration Installation section to level refrigerator.

Doors are difficult to open

- The gaskets are dirty or sticky.
  - Clean the gaskets and the surfaces that they touch. Rub a thin coat of appliance polish or kitchen wax on the gaskets after cleaning
- Door was recently closed.
  - When you open the door, warmer air enters the refrigerator. As the warm air cools, it can create a vacuum. If the door is hard to open, wait one minute to allow the air pressure to equalize, then see if it opens more easily.

Refrigerator wobbles or seems unstable

- Leveling legs are not adjusted properly.
  - Refer to the Leveling and Door Alignment section.
- Floor is not level.
  - It may be necessary to add shims under the leveling legs or rollers to complete installation

Lights do not work.

- LED interior lighting failure.
  - The refrigerator compartment lamp is LED interior lighting, and service should be performed by a qualified technician.

Refrigerator has an unusual odor.

- The Air Filter may need to be set to the MAX setting or replaced.
  - Set the Air Filter to the MAX setting. If the odor does not go away within 24 hours, the filter may need to be replaced. See the Replacing the Air Filter section for replacement instructions.

The interior of the refrigerator is covered with dust or soot.

- The refrigerator is located near a fire source, such as a fireplace, chimney, or candle.
  - Make sure that the refrigerator is not located near a fire source, such as a fireplace, chimney or candle.

**Noises**

## Clicking

- The defrost control will click when the automatic defrost cycle begins and ends. The thermostat control (or refrigerator control on some models) will also click when cycling on and off.
  - Normal Operation

## Rattling

- Rattling noises may come from the flow of refrigerant, the water line on the back of the unit, or items stored on top of or around the refrigerator.
  - Normal Operation
- Refrigerator is not resting solidly on the floor.
  - Floor is weak or uneven or leveling legs need to be adjusted. See the Leveling and Door Alignment section.
- Refrigerator with linear compressor was jarred while running.
  - Normal Operation

## Whooshing

- Evaporator fan motor is circulating air through the refrigerator and freezer compartments.
  - Normal Operation
- Air is being forced over the condenser by the condenser fan.
  - Normal Operation

## Gurgling

- Refrigerant flowing through the cooling system.
  - Normal Operation

## Popping

- Contraction and expansion of the inside walls due to changes in temperature.
  - Normal Operation

## Sizzling

- Water dripping on the defrost heater during a defrost cycle.
  - Normal Operation

## Vibrating

- If the side or back of the refrigerator is touching a cabinet or wall, some of the normal vibrations may make an audible sound.
  - To eliminate the noise, make sure that the sides and back cannot vibrate against any wall or cabinet.

## Dripping

- Water running into the drain pan during the defrost cycle
  - Normal Operation

## Pulsating or highpitched sound

- Your refrigerator is designed to run more efficiently to keep your food items at the desired temperature. The high efficiency compressor may cause your new refrigerator to run longer than your old one, but it is still more energy efficient than previous models. While the refrigerator is running, it is normal to hear a pulsating or highpitched sound.
  - Normal Operation

## Wi-Fi

### Trouble connecting appliance and smartphone to Wi- Fi network

- The password for the Wi-Fi network was entered incorrectly.
  - Delete your home Wi-Fi network and begin the registration process again.
- Mobile data for your smartphone is turned on.
  - Turn off the Mobile data on your smartphone before registering the appliance.
- The wireless network name (SSID) is set incorrectly.
  - The wireless network name (SSID) should be a combination of English letters and numbers. (Do not use special characters.)
- The router frequency is not 2.4 GHz.
  - Only a 2.4 GHz router frequency is supported. Set the wireless router to 2.4 GHz and connect the appliance to the wireless router. To check the router frequency, check with your Internet service provider or the router manufacturer.
- The distance between the appliance and the router is too far.
  - If the appliance is too far from the router, the signal may be weak and the connection may not be configured correctly. Move the router closer to the appliance or purchase and install a Wi-Fi repeater.

### Warning

This content is compiled from multiple sources and is provided for reference purposes only. It may not be complete or fully applicable to all situations. If you are unable to resolve your issue, please contact the product manufacturer or an authorized service provider for official support.

---

Document generated by [ManualsFile](#)

