

PARTS AND FEATURES

This manual covers different models. The cooktop you have purchased may have some or all of the items listed.

36" (91.4 cm) Cooktop

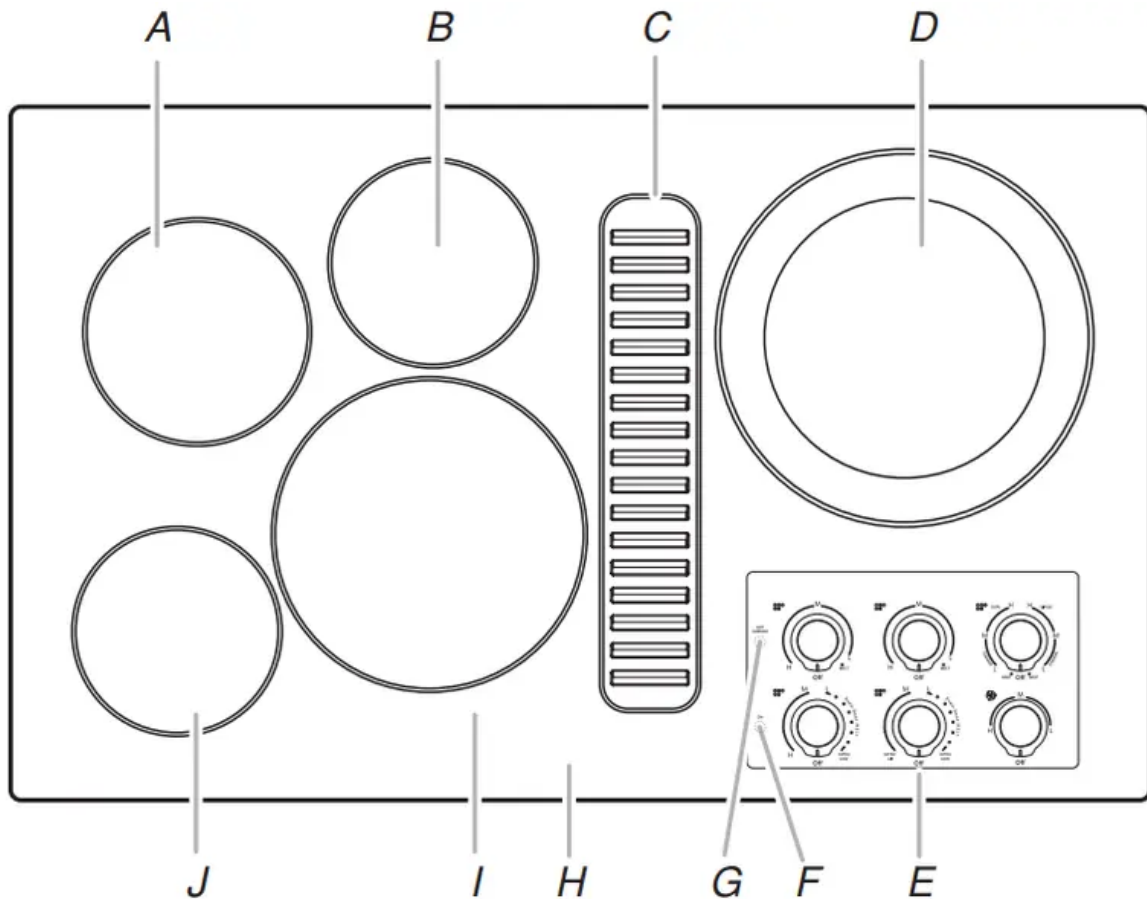

- A. 8" (20.3 cm) single element
- B. 6" (15.2 cm) single element
- C. Downdraft vent grille
- D. 12"/9" (30.5 cm/22.9 cm) dual element
- E. Control panel
- F. On indicator light
- G. Hot Surface indicator light
- H. Ceramic cooking surface
- I. 10" (25.4 cm) single element
- J. 6" (15.2 cm) single element

COOKTOP USE

Cooktop Controls

WARNING: Fire Hazard

Turn off all controls when done cooking.

Failure to do so can result in death or fire.

The controls can be set to anywhere between H and L.

To Set:

Push in and turn knob to desired heat setting. Use the following chart as a guide when setting heat levels.

Setting	Recommended Use
H (High)	<ul style="list-style-type: none">• Bring liquid to a boil.
Medium High (between H and M)	<ul style="list-style-type: none">• Hold a rapid boil.• Quickly brown or sear food
M (Medium)	<ul style="list-style-type: none">• Maintain a slow boil.• Fry or sauté foods.• Cook soups, sauces, and gravies.
Medium Low (between M and L)	<ul style="list-style-type: none">• Stew or steam food.• Simmer.
L (Low)	<ul style="list-style-type: none">• Keep cooked foods warm.
Dual/Triple Circuit Elements	<ul style="list-style-type: none">• Home canning• Large-diameter cookware• Large quantities of food
Melt	<ul style="list-style-type: none">• Melt chocolate or butter.

REMEMBER: When cooktop is in use, the entire cooktop area may become hot.

Hot Surface Indicator Light

This unit features a Hot Surface indicator light. The Hot Surface indicator light will glow as long as any surface cooking area is too hot to touch, even after the surface cooking area(s) is turned off. If the cooktop is ON when a power failure occurs, the Hot Surface indicator light will remain on after the power is restored to the cooktop. It will remain on until the cooktop has cooled completely.

Cooktop On Indicator Light

Each cooktop has a Cooktop On indicator light. When the control knob is ON, the light will glow.

Dual Element

The dual-size element offers flexibility depending on the size of the cookware. Single size can be used in the same way as a regular element. The dual size combines the single and outer element and is recommended for larger cookware, large quantities of food, and home canning.

For best High heat performance, match burner to cookware size.

For best Low heat or Simmer performance, match cookware to largest cooking area ring and use single ring for desired performance.

Dual Element

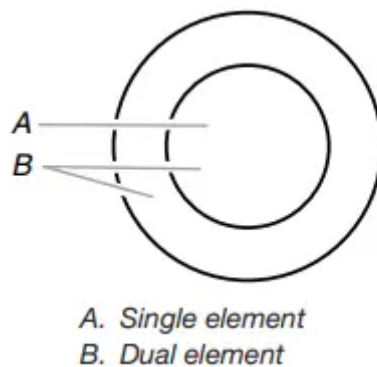

To Use Single:

1. Push in and turn knob from the OFF position to the SINGLE zone anywhere between L and H.
2. Turn knob to OFF when finished.

To Use Dual:

1. Push in and turn knob from the OFF position to the DUAL zone anywhere between L and H.
2. Turn knob to OFF when finished.

Melt

The Melt function is available on all the surface cooking elements and is ideal for melting chocolate or butter.

To Use:

1. Push in and turn knob to MELT.
2. Turn knob to OFF when finished.

Ceramic Glass

The surface cooking area will glow red when an element is ON, except when Melt or Warming Zone (on some models) are used. It may cycle on and off to maintain the selected heat level.

It is normal for the surface of light-colored ceramic glass to appear to change color when surface cooking areas are hot. As the glass cools, it will return to its original color.

Cleaning off the cooktop before and after each use will help keep it free from stains and provide the most even heating. On cooktops with light-colored ceramic glass, soils and stains may be more visible, and may require more cleaning and attention. Cooktop cleaner and a cooktop scraper are recommended. For more information, see the “General Cleaning” section.

- Avoid storing jars or cans above the cooktop. Dropping a heavy or hard object onto the cooktop could crack the cooktop.
- To avoid damage to the cooktop, do not leave a hot lid on the cooktop. As the cooktop cools, air can become trapped between the lid and the cooktop, and the ceramic glass could break when the lid is removed.
- For foods containing sugar in any form, clean up all spills and soils as soon as possible. Allow the cooktop to cool down slightly. Then, while wearing oven mitts, remove the spills using a scraper while the surface is still warm. If sugary spills are allowed to cool down, they can adhere to the cooktop and can cause pitting and permanent marks.
- To avoid scratches, do not slide cookware or bakeware across the cooktop. Aluminum or copper bottoms and rough finishes on cookware or bakeware could leave scratches or marks on the cooktop.
- Do not cook popcorn in prepackaged aluminum containers on the cooktop. They could leave aluminum marks that cannot be removed completely.
- To avoid damage to the cooktop, do not allow objects that could melt, such as plastic or aluminum foil, to touch any part of the entire cooktop.
- To avoid damage to the cooktop, do not use the cooktop as a cutting board.
- Use cookware about the same size as the surface cooking area. Cookware should not extend more than ½" (1.3 cm) outside the area.

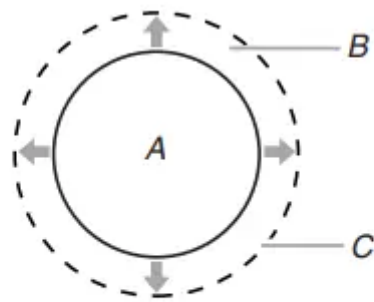

A. Surface cooking area
 B. Cookware/Canner
 C. ½" (1.3 cm) maximum overhang

- Use flat-bottomed cookware for best heat conduction and energy efficiency. Cookware with rounded, warped, ribbed, or dented bottoms could cause uneven heating and poor cooking results.
- Determine flatness by placing the straight edge of a ruler across the bottom of the cookware. While you rotate the ruler, no space or light should be visible between it and the cookware.
- Make sure the bottoms of pots and pans are clean and dry before using them. Residue and water can leave deposits when heated.
- To avoid damage to the cooktop, do not cook foods directly on the cooktop.

Downdraft Ventilation System

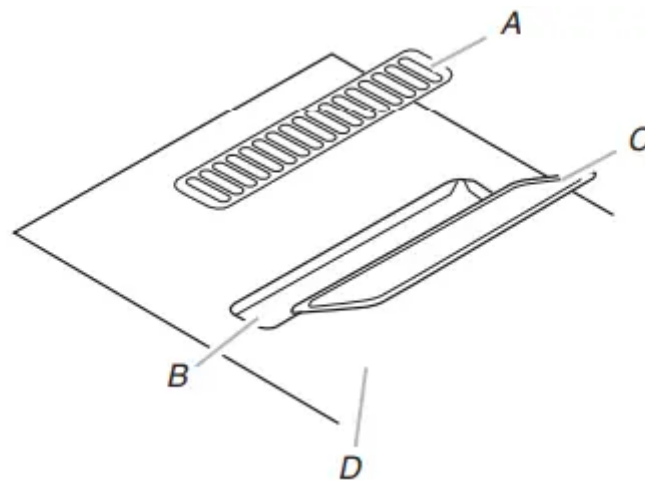

- A. Vent grille
- B. Plenum chamber
- C. Removable grease filter
- D. Ceramic glass top

The downdraft ventilation system consists of a vent cover, filter, and vent fan. The downdraft ventilation system removes cooking vapors, odors, and smoke from foods prepared on the cooktop.

IMPORTANT: For optimal performance, operate downdraft ventilation system with the filter properly installed.

To avoid the buildup of grease, the filter should be cleaned often.

For more information on proper filter placement and cleaning, see “Downdraft Ventilation System” in the “General Cleaning” section.

To Use:

Turn vent fan knob to L (low), M (medium) or H (high). Turn vent fan knob to OFF when finished cooking or when the cooktop is not in use

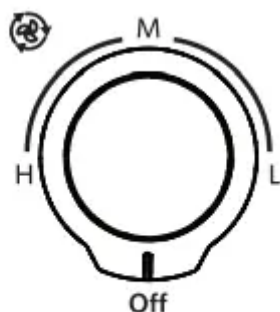

Home Canning

When canning for long periods, alternate the use of surface cooking areas, elements, or surface burners between batches. This allows time for the most recently used areas to cool.

- Center the canner on the grate or largest surface cooking area or element. On electric cooktops, canners should not extend more than ½" (1.3 cm) beyond the surface cooking area or element.
- Do not place canner on two surface cooking areas, elements or surface burners at the same time.
- On ceramic glass models, use only flat-bottomed canners.
- For more information, contact your local agricultural department. Companies that manufacture home canning products can also offer assistance.

Cookware

IMPORTANT: Do not leave empty cookware on a hot surface cooking area, element, or surface burner.

Ideal cookware should have a flat bottom, straight sides, and a well-fitting lid and the material should be of medium-to-heavy thickness.

Rough finishes may scratch the cooktop. Aluminum and copper may be used as a core or base in cookware. However, when used as a base, they can leave permanent marks on the cooktop or grates.

Cookware material is a factor in how quickly and evenly heat is transferred which affects cooking results. A nonstick finish has the same characteristics as its base material. For example, aluminum cookware with a nonstick finish will take on the properties of aluminum.

Use the following chart as a guide for cookware material characteristics.

Cookware	Characteristics
Aluminum	<ul style="list-style-type: none"> • Heats quickly and evenly. • Suitable for all types of cooking • Medium or heavy thickness is best for most cooking tasks.
Cast iron	<ul style="list-style-type: none"> • Heats slowly and evenly. • Good for browning and frying • Maintains heat for slow cooking.
Ceramic or ceramic glass	<ul style="list-style-type: none"> • Follow manufacturer's instructions. • Heats slowly but unevenly. • Ideal results on low-to-medium heat settings
Copper	<ul style="list-style-type: none"> • Heats very quickly and evenly.
Earthenware	<ul style="list-style-type: none"> • Follow manufacturer's instructions. • Use on low heat settings
Porcelain enamel-steel or cast iron	<ul style="list-style-type: none"> • See stainless steel or cast iron.
Stainless steel	<ul style="list-style-type: none"> • Heats quickly but unevenly. • A core or base of aluminum or copper on stainless steel provides even heating.



COOKTOP CARE

General Cleaning

IMPORTANT: Before cleaning, make sure all controls are OFF and the cooktop is cool. Always follow label instructions on cleaning products.

Soap, water, and a soft cloth or sponge are suggested first, unless otherwise noted.

CERAMIC GLASS

To avoid damage to ceramic glass, do not use steel wool, abrasive powder cleansers, chlorine bleach, rust remover, or ammonia.

Always wipe with a clean, wet cloth or sponge and dry thoroughly to avoid streaking and staining.

Cooktop Polishing Creme is recommended for regular use to help avoid scratches, pitting, and abrasions and to condition the cooktop. It may be ordered as an accessory. See the “Assistance or Service” section to order.

A Cooktop Scraper is also recommended for stubborn soils, and can be ordered as an accessory. See the “Assistance or Service” section to order. The Cooktop Scraper uses razor blades. Store razor blades out of the reach of children.

Cleaning Method:

Light to moderate soil

- Paper towels or clean damp sponge

Sugary spills (jellies, candy, syrup)

- Cooktop Scraper: Scrape sugary spills while the cooktop is still warm. You may want to wear oven mitts while doing so.
- Cooktop Polishing Creme and clean damp paper towel: Clean as soon as cooktop has cooled down. Rub creme into surface with a damp paper towel or soft cloth. Continue rubbing until white film disappears.

Heavy soil, dark streaks, specks, and discoloration

- Cooktop Polishing Creme or nonabrasive cleanser: Rub product into soil with a damp paper towel or soft cloth. Continue rubbing until white film disappears.

Burned-on soil

- Cooktop Polishing Creme and Cooktop Scraper: Rub creme into soil with damp paper towel. Hold scraper as flat as possible on surface and scrape. Repeat for stubborn spots. Polish entire cooktop with creme and paper towel.

Metal marks from aluminum and copper

Cooktop Polishing Creme: Clean as soon as cooktop has cooled down. Rub creme into surface with a damp paper towel or soft cloth. Continue rubbing until white film disappears. The marks will not totally disappear but, after many cleanings, become less noticeable.

Tiny scratches and abrasions

- Cooktop Polishing Creme: Rub creme into surface with a damp paper towel or soft cloth. Continue rubbing until white film disappears. Scratches and abrasions do not affect cooking performance and, after many cleanings, become less noticeable.

COOKTOP CONTROLS

To avoid damage to the cooktop controls, do not use steel wool, abrasive cleansers, or oven cleaner.

To avoid damage, do not soak knobs.

When replacing knobs, make sure knobs are in the Off position.

Do not remove seals under knobs.

Cleaning Method:

- Soap and water: Pull knobs straight away from control panel to remove.
- When replacing knobs, make sure they are in the Off position.

STAINLESS STEEL (on some models)

To avoid damage to stainless steel surfaces, do not use soap-filled scouring pads, abrasive cleaners, Cooktop Cleaner, steelwool pads, gritty washcloths, or abrasive paper towels.

Rub in direction of grain to avoid damaging.

Cleaning Method:

- Liquid detergent or all-purpose cleaner: Rinse with clean water and dry with soft, lint-free cloth.
- Vinegar for hard water spots.

DOWNDRAFT VENTILATION SYSTEM

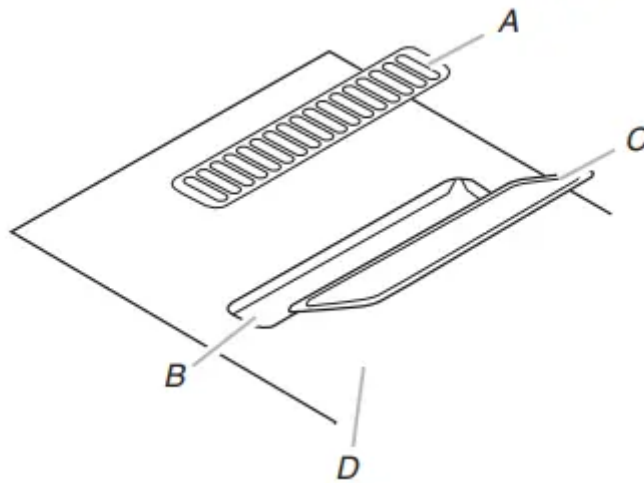

- A. Vent grille
- B. Plenum chamber
- C. Removable grease filter
- D. Ceramic glass top

Vent Grille

Cleaning Method:

- Grasp the opening and lift the vent grille of the cooktop.
- Wipe clean or wash in sink: Nonabrasive plastic scrubbing pad and mildly abrasive cleanser
- Dishwasher: Use mild detergent.

Removable Grease Filter

The filter is a permanent type and should be cleaned when soiled.

Cleaning Method:

- Turn off the downdraft ventilation system before removing the filter.
- Remove vent grate then lift the filter out of the vent chamber.
- Clean the filter in the sink with warm water and detergent or in the dishwasher.
- Replace the filter.

The filter should always be placed at an angle. As you face the front of the cooktop, the top of the filter should rest against the left side of the vent opening.

The bottom of the filter should rest against the right side of the vent chamber at the bottom.

If the filter is flat against the fan wall, ventilation effectiveness will be reduced.

Ventilation Chamber

The ventilation chamber, which houses the filter, should be cleaned in the event of spills or when it becomes coated with a film of grease.

Cleaning Method:

- Mild household detergent or cleanser and paper towel, damp cloth, or sponge: Apply detergent or cleanser to paper towel, damp cloth, or sponge, not directly to the ventilation chamber

TROUBLESHOOTING

Problem	Possible Causes and/or Solutions
Nothing will operate	A household fuse has blown or a circuit breaker has tripped - Replace the fuse or reset the circuit breaker. If the problem continues, call an electrician.
Cooktop will not operate	Control knob set incorrectly - Push in knob before turning to a setting
Excessive heat around cookware on cooktop	Cookware is not the proper size - Use cookware about the same size as the surface cooking area, element, or surface burner. Cookware should not extend more than ½" (1.3 cm) outside the cooking area.
Cooktop cooking results not what expected	Proper cookware is not being used - See the "Cookware" section. Control knob is not set to the proper heat level - See the "Cooktop Controls" section. Cooktop is not level - Level the cooktop. See the Installation Instructions.
Downdraft performance not what expected	The filter is not clean - See the "General Cleaning" section for instructions on cleaning the filter.

Warning

This content is compiled from multiple sources and is provided for reference purposes only. It may not be complete or fully applicable to all situations. If you are unable to resolve your issue, please contact the product manufacturer or an authorized service provider for official support.

