

## User Manual

# Getting started

## Features

### The Google Assistant™ on Android TV™

Android TV brings a world of content to your biggest screen. With the Google Assistant built in, you can quickly access entertainment, get answers, and control devices around your home. Find the latest blockbuster, check the score of the big game, or dim the lights. Press the Google Assistant button on your remote to get started.

### Google Play

Android TV offers thousands of movies, shows, and games from Google Play, and your favorite apps. Discover your favorite content, apps, and games on Google Play.

### DTV / Analog TV / CATV

You can use your remote to select channels which are broadcast in digital format and conventional analog format. Also, cable and satellite subscribers can access their TV channels.

### Information display

You can display on the TV screen the title, contents (DTV only) and other information on the current program.

### Autoprogram

This unit automatically scans and memorizes channels available in your area, eliminating difficult setup procedures.

### Parental controls

This feature allows you to block children's access to inappropriate programs.

### Closed caption decoder

Built-in closed caption decoder displays text for closed caption supported programs.

### MTS / SAP tuner

Audio can be selected from the remote.

### Auto standby

If there is no input signal and no operation for 15 minutes, the unit will go into standby mode automatically.

### Sleep timer

You can set the unit to go into standby mode after a specific amount of time.

## **Choices for on-screen language**

Select your on-screen language: English, Spanish or French.

## **Stereo sound function**

## **Various adjustments for picture and sound**

Customizes picture quality suitable for your room and sets your sound preference.

## **HDMI control**

HDMI control allows your other HDMI link devices to be controlled by the HDMI cable connected to your TV.

## **HDMI input**

## **HDMI-DVI input**

If your video device has a DVI output jack, use an HDMI-DVI conversion cable to connect the unit.

## **AV input**

Audio and video input from an external device.

## **Digital audio output**

## **Headphone audio output**

Headphone 3.5 mm stereo jack for personal listening.

## **Unpacking**

Cover a table top with a cloth or blanket to avoid damage to the TV screen. Hold both sides of the TV set to place on the table.

1 Open the top flaps of the box.



2 Remove all accessories.

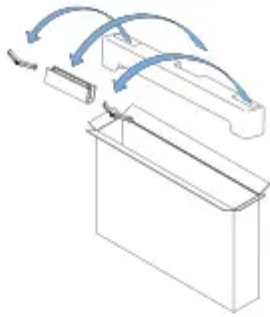

3

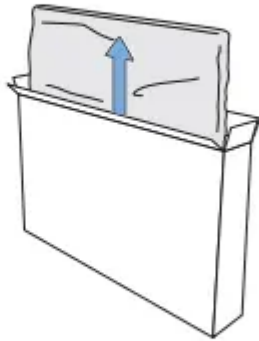

4

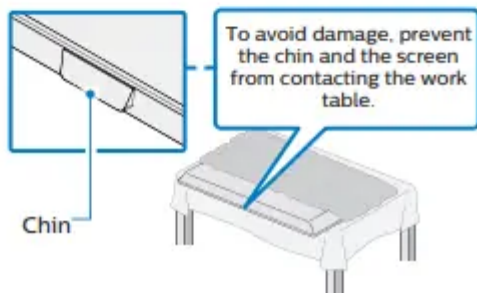

## Installing the stands

1 Remove the tape on the bottom of the TV set and the plastic bag.



2 Fasten the stand to the TV with 4 screws.

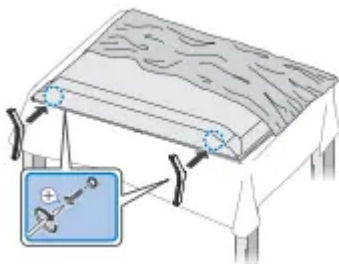

3 Both stands should now be securely fastened.

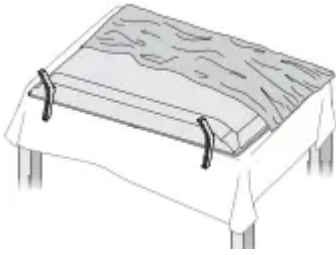

## Installing the Batteries

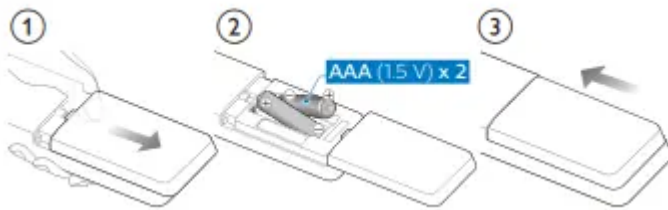

1 Open the battery cover by firmly sliding down.

2 Insert 2 AAA (1.5 V) batteries matching the polarity indicated inside battery compartment of the remote.

3 Slide the cover back into position.

## Remote



- ① **Microphone**
- ② **⏻ (POWER)**  
Turns the TV on and off of standby.
- ③ **SAP**  
Selects audio mode (MONO / STEREO / SAP) / audio language.
- ④ **📺 (FORMAT)**  
Adjusts the picture size on the TV screen.
- ⑤ **📺 (TV GUIDE)**  
Access to the Electronic Program Guide (EPG).  
It allows you to find channels and content easily.
- ⑥ **⬅️ (BACK)**  
Returns to the previous menu screen.
- ⑦ **VOL + / -**  
Adjusts the volume.
- ⑧ **🔇 (MUTE)**  
Turns the sound on and off.
- ⑨ **CC**  
Selects closed caption settings.
- ⑩ **ℹ️ (INFO)**  
Displays input and resolution information.
- ⑪ **The Google Assistant**  
Press the Assistant button on your remote to talk to your Google Assistant.
- ⑫ **☰ (OPTIONS)**  
Displays a list of menu options applicable to the active screen.
- ⑬ **OK**  
Press to decide the command of setting when the Home menu is displayed.
- ⑭ **⬆️ ⬆️ ⬆️ (NAVIGATION buttons)**  
Moves the cursor, selects the on-screen menu items.
- ⑮ **🏠 (HOME)**  
Access to your apps, Live TV, input devices, settings, and the Google Play Store.
- ⑯ **PREV.CH**  
Direct access to the Live TV channels.  
Displays the last selected terminal or channel.
- ⑰ **COLOR buttons**  
Works as direct access to user specified net apps.
- ⑱ **📺 (INPUT)**  
Change input source.  
Select and change access to the attached devices such as Blu-ray player, gaming consoles, or cable box.
- ⑲ **CH + / -**  
Selects a channel.
- ⑳ **0 - 9 (NUMBER buttons)**  
Used to enter a channel / program number.  
• **(DOT)** : Use with **0-9** to select digital channels.  
For example, to enter 2.1, press
- ㉑ **EasyLink buttons**
  - ⏮️ / ⏭️ : Skips backward or forward chapters, titles or tracks on a disc.
  - : Stops the disc playback.
  - ⏮️ / ⏭️ : Searches backward or forward through the disc.
  - ⏸️ : Starts, pauses or resumes playback.

## Control panel

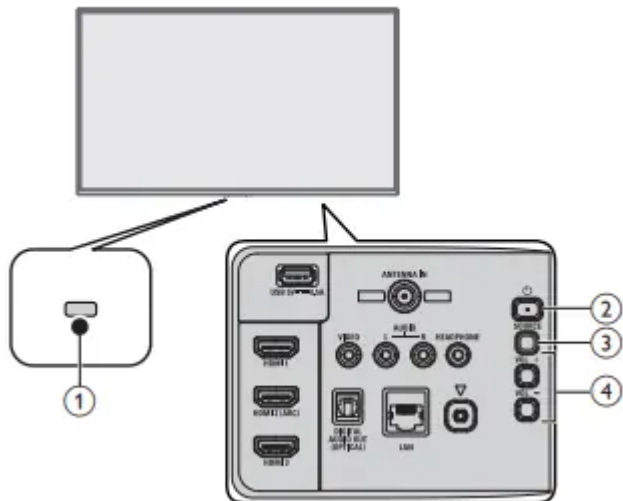

**1 Remote sensor** Receives IR signal from remote.

**2  (POWER)** Turns the TV on or switches the TV into standby mode. Turns the TV on and off of standby.

**3 SOURCE** Selects connected devices.

**4 VOL + / -** Adjusts the volume.

**VOL +** : Volume up

**VOL -** : Volume down

## Terminals

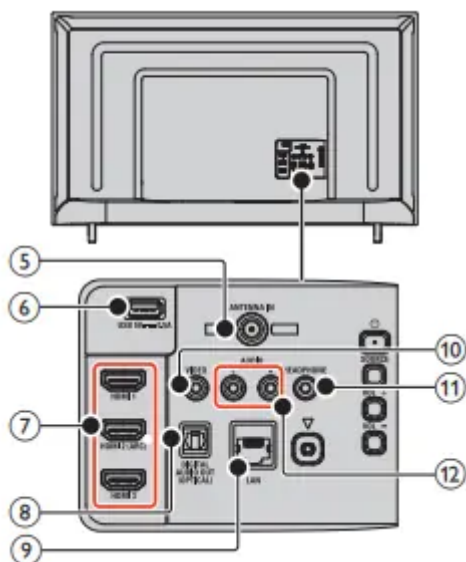

**5 75 ohm Cable / Antenna connection**

Signal input from an antenna or Cable / Satellite set-top boxes.

**6 USB terminal**

Data input from USB memory stick only.

### **7 HDMI input jack(s)**

Digital audio and video input from high definition digital devices such as DVD / Blu-ray Disc™ players, Soundbar / cable / satellite set-top boxes, PC's, etc.

- HDMI-DVI / Analog audio (L/R) jacks signal
- Composite video / Analog audio (L/R) jacks signal
- PC connection / Analog audio (L/R) jacks signal with stereo mini 3.5 mm plug audio cable on PC

\* For HDMI 2 only : In addition to normal HDMI functionality, it outputs TV audio to an HDMI-ARC compliant device, such as a soundbar and home theater system.

### **8 Digital audio output (Optical) jack**

Digital audio (SPDIF) output to home theaters and other digital audio systems.

### **9 Ethernet port**

For internet connection using an Ethernet cable with an RJ-45 connector.

### **10 Composite video (VIDEO) input jack**

Connect composite analog video signal.

### **11 Headphone audio output jack**

Headphone 3.5 mm stereo jack for personal listening.

### **12 Analog audio (L/R) input jacks**

Connect analog audio signals from;

- HDMI-DVI / Analog audio (L/R) jacks signal
- Composite video / Analog audio (L/R) jacks signal
- PC connection / Analog audio (L/R) jacks signal with stereo mini 3.5 mm plug audio cable on PC

## **Connecting antenna or cable / satellite / IPTV set-top box**

Be sure your antenna or another device is connected properly before plugging in the AC power cord.

### **If connecting to an antenna through an RF cable**

Any DTV programs that are broadcast in your area can be received for free through an antenna connection.

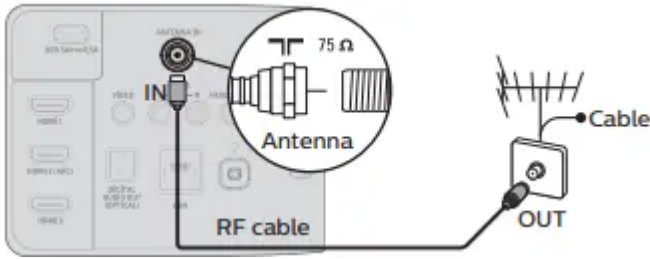

**If connecting cable / satellite / IPTV set-top box using an RF cable**

If the TV is connected to a cable / satellite set-top box via a coaxial connection, set the TV to channel 3/4 or the channel specified by the service provider.

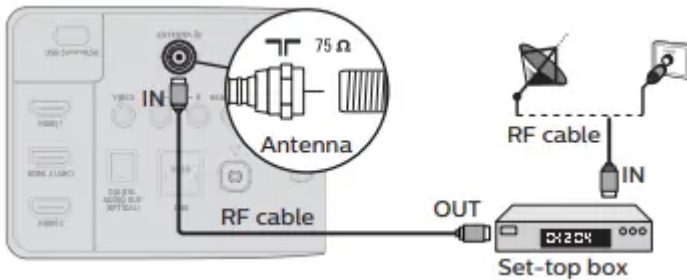

**If connecting cable / satellite / IPTV set-top box using an HDMI cable**

If the TV is connected to a cable / satellite set-top box via an HDMI cable, make sure you select the correct source by using  (INPUT).

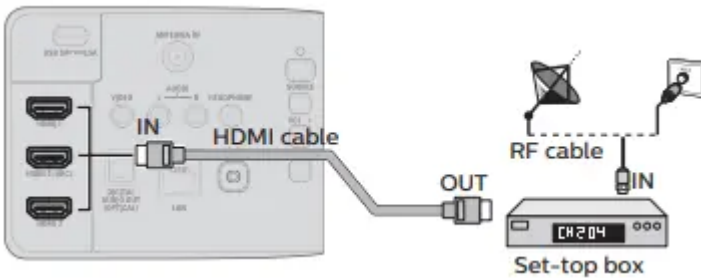

**Connecting a cable / satellite / IPTV set-top box, Blu-ray Disc™ / DVD recorder via composite connectors and analog audio**

Do not place your recorder too close to the screen because some recorders can be susceptible to harmful interference from the TV.



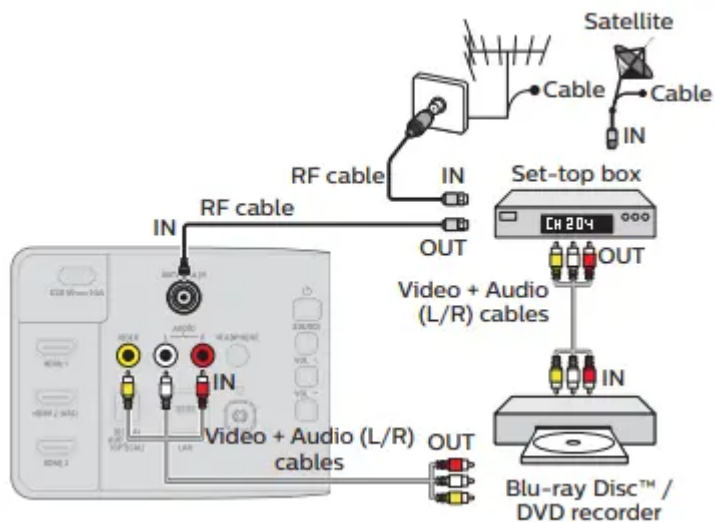

## Plugging in the AC power cord

Make sure that the AC power cord must be plugged to an AC outlet after all the necessary connections are made

**No included cables are used with these connections:**

- Please purchase the necessary cables at your local store.

**Before you connect the AC power cord:**

Be sure other devices are connected properly before plugging in the AC power cord.

## Selecting your connection quality

### HDMI - Highest quality

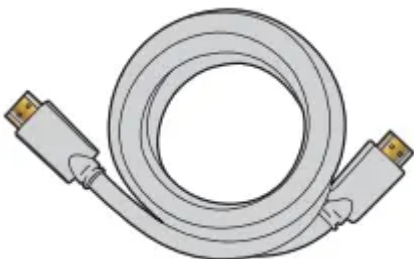

Supports high-definition digital signals and gives highest picture and sound quality. Video and audio signals are combined in one cable. You must use HDMI for full high-definition video and to enable HDMI control (HDMI CEC).

### Composite - Basic quality

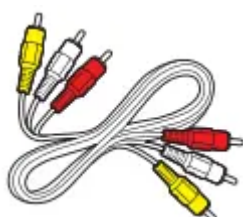

For analog connections. Composite video / Audio analog cable usually combine a yellow video cable with red / white audio (L/R) cables.

## Connecting your devices

### HDMI digital connection

HDMI connection offers the highest picture quality. HDMI (High-Definition Multimedia Interface) transports high definition digital video and multi-channel digital audio through a single cable.

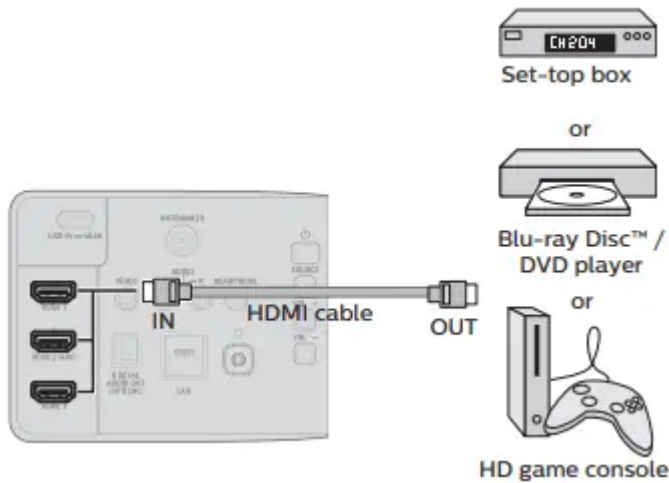

### HDMI-DVI connection

This unit can be connected to a device that has a DVI terminal. Use an HDMI-DVI conversion cable for this connection and it requires audio cable for analog audio signal as well.

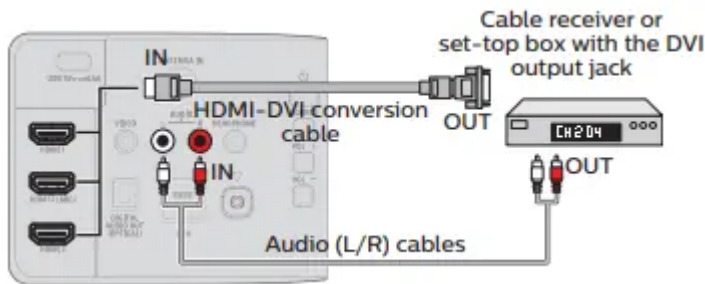

### HDMI-ARC connection

HDMI-ARC allows you to use HDMI control to output TV audio directly to a connected audio device, without the need for an additional digital audio cable

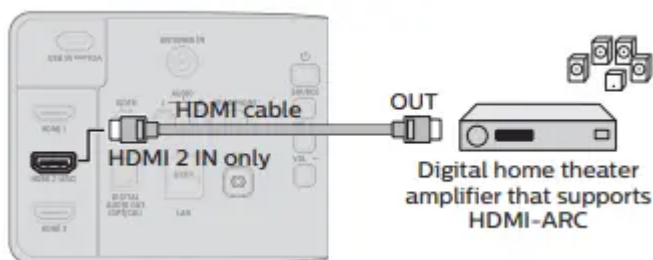

### HDMI EDID Version

If there are issues with picture/color and/or sound when connecting an external device using the HDMI port, please try switching the HDMI mode following the instructions below.

1. Press **INPUT** to switch input device list.
2. Press **OPTIONS** on your remote and navigate to Settings and press OK.
3. Select Device Preferences and press OK.
4. Select Inputs and press OK.
5. Select HDMI EDID Version and press OK.

### Digital audio output connection

If you connect this unit to an external digital audio device, you can enjoy multi-channel audio like 5.1ch digital broadcasting sound. Use a digital audio optical cable to connect the unit to external digital audio devices.

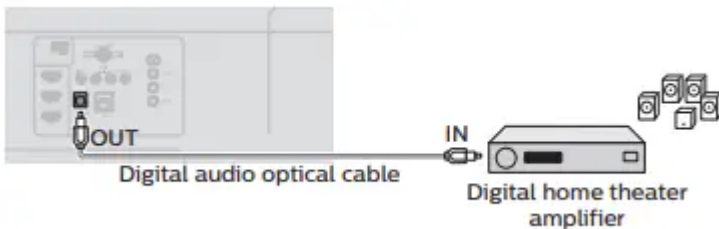

### Composite analog video connection

Composite analog video connection offers standard picture quality for video devices connected to the unit. If you connect to the unit's composite video (VIDEO) input jack, connect audio cables to the audio (L/R) input jacks. When the audio is monaural, then only connect to the audio L input jack

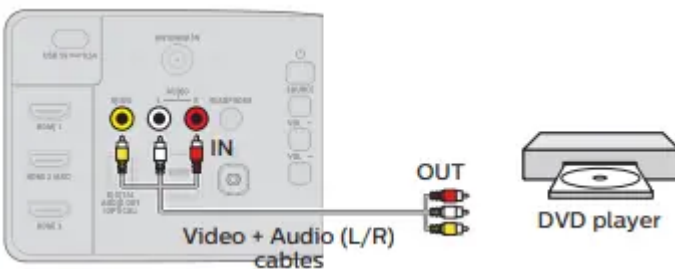

### Connecting the TV to the internet using an Ethernet cable

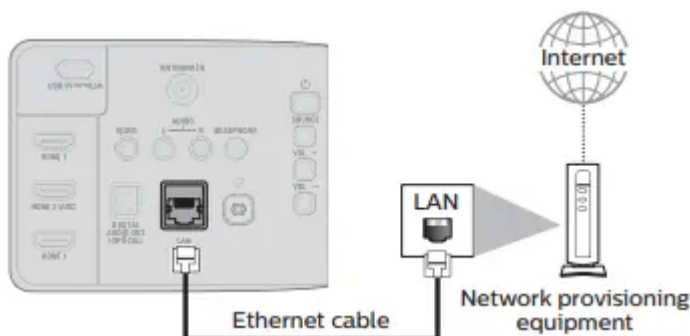

## PC connection

PC content can also be sent to the TV via any Google Chromecast compatible application.

### HDMI connection

This unit can be connected to your PC that has an HDMI terminal. Use an HDMI cable for this digital connection.

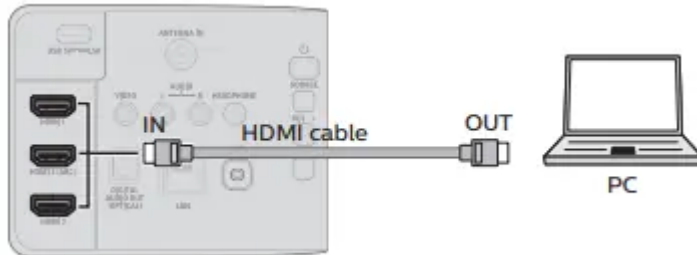

### HDMI-DVI connection

This unit can be connected to your PC that has a DVI terminal. Use an HDMI-DVI conversion cable for this video digital connection and it requires stereo mini 3.5 mm plug audio cable for analog audio signal as well.

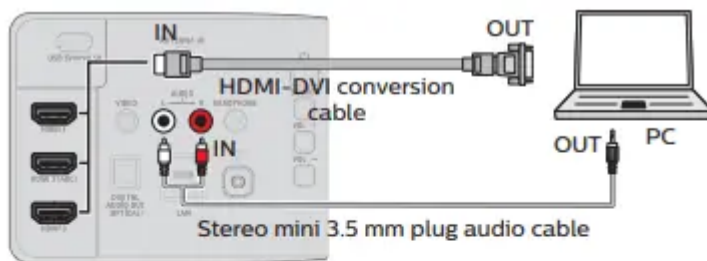

The following PC-input video signals can be displayed:

Format	Resolution	Refresh rate
VGA	640 x 480	60 Hz
SVGA	800 x 600	
XGA	1,024 x 768	
WXGA	1,280 x 768	
	1,360 x 768	24/30/60 Hz
FHD	1,920 x 1,080	
UHD	3,840 x 2,160*	
	4,096 x 2,160*	

### Note(s)

- Please purchase a HDMI-DVI conversion cable that has a ferrite core.
- The following operations may reduce noise.
  - Attach a ferrite core to the AC power cord of your PC.
  - Unplug the AC power cord and use the built-in battery of your portable / laptop PC.

- Some HDMI cables and devices may not be compatible with the TV due to different HDMI specifications.
- Use an HDMI cable with the HDMI logo (a certified HDMI cable). High speed HDMI cable is recommended for the better compatibility.
- The unit accepts 480p, 720p, 1080p and 2160p video signals only when using the HDMI connection and HDMI-DVI connection. When connecting with HDMI-DVI, the operation is maximum 2160p@30 Hz.
- HDMI-DVI connection requires separate audio connections as well and the audio signals are output as analog (L/R) audio.
- DVI does not display 480i image which is not in compliance with CTA-861-G.

## Use your TV

### Switching on your TV and putting it in standby mode

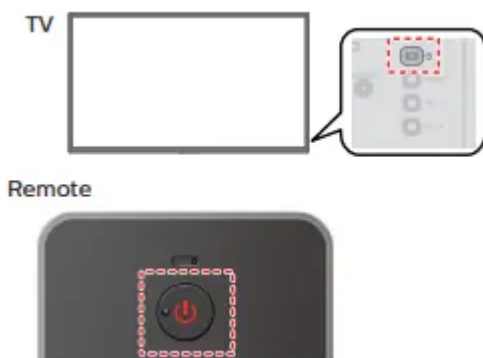

Turns the TV on and off of standby.

- Press **⏻** (POWER) on the TV or the remote, then TV will go to suspend standby.
- Press and hold **⏻** (POWER) on the TV or the remote, then TV will go to standby mode completely

### Adjusting volume

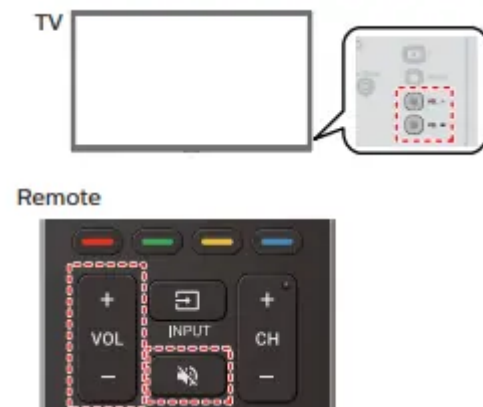



To decrease or increase volume

- Press VOL + / – on the TV or the remote.

VOL + : Volume up

VOL – : Volume down

To mute or unmute sound

- Press  (MUTE) on the remote to mute the sound.
- Press  (MUTE) again or VOL + / – to recover the original sound.

## Switching channels



To change channels, you can do any of the following:



- Press CH + / –\* on the remote.
- Use the NUMBER buttons\* on the remote.
- Press ▲▼ on the remote for digital channels only.

## Watching channels from an external device

Switching each input mode can easily switch with the remote between TV and external devices when they are connected to the unit.

1 Turn on the set-top box or the connected device.



① Press  (INPUT) and use   to select the set-top box or the connected device and wait a few seconds till the picture appears

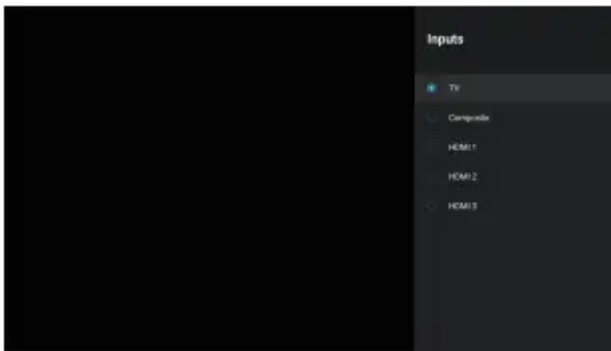

② Use the remote of the set-top box or the connected device to select channels.

## Access the Home menu

1 Press  (HOME)



## Guide to Home menu

From the Android TV home screen, you can easily access movies, TV shows, music, apps, input devices, settings, and more. To go back to the home screen at any time, press  (HOME) on your remote

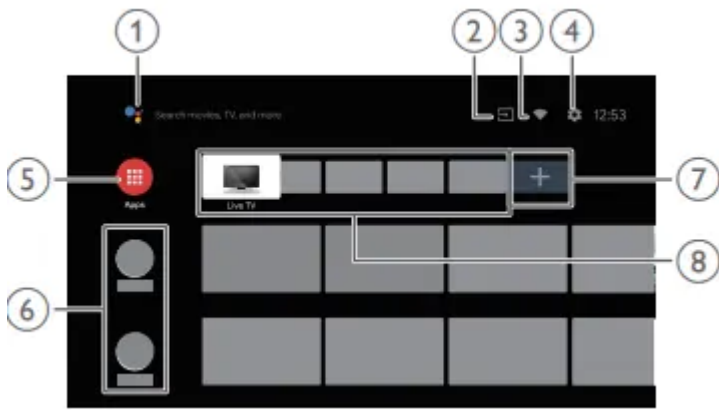

## 1 The Google Assistant

With the Google Assistant, quickly access entertainment, control smart devices, get answers on screen, and more using your voice.

**2 Input :** Toggle inputs between your favorite source devices.

**3 Network condition :** Display the network status and open network settings if selected.

**4 Settings :** Configure your television settings and connect to wireless devices.

**5 Apps :** Apps gallery

You must sign in with a Google account to visit and download apps from the Google Play store.

## 6 How to rearrange channels

Within the row, you want to rearrange, press ◀ on your remote.

To rearrange channels,

Select arrow (▲▼) icon, and press OK.

Use ▲▼ to move up or down. Press OK.

To delete channels,

Select minus (-) icon, and press OK.

## 7 Install additional apps

Select the "+" and click on the Google

Play Store to expand your entertainment library.

## 8 How to move or delete applications

Select the application and long press OK on your remote.

To move,

Select Move in the list, and press OK. Use ▶◀ to move left or right. Press OK.

To delete,

Select Remove from favorites in the list, and press OK.

## Apps

You can download the apps.

1 Press  (HOME) and use    to select Apps, then press OK.

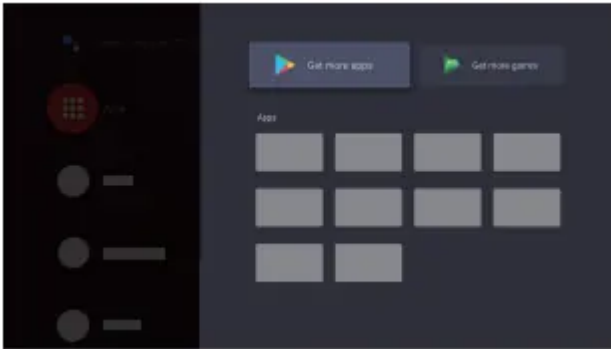

2 Select "Get more apps" to open the Google Play Store apps.

3 Search for the app or type of app you want to install.

4 Select the app.

5 Select install.

## The Google Assistant



Press the Google Assistant to launch the Google Assistant . You can operate what you want to do and what you want to ask by hands-free.

## Microphone



1 Activating the Google Assistant on the home screen will launch a Google Query.

- Activating the Google Assistant within an app will allow you to search and find information only related to a specific app.

2 Speak into the microphone located on the top of your remote. Speech examples may be displayed depending on your model. Refer to the Google web site

## Picture format

Display modes can be selected when your TV receives a 16:9 or 4:3 video signal.

Press  (FORMAT) repeatedly to switch the TV aspect ratio



<b>Automatic</b>	Displays a picture at maker recommended picture format setting.
<b>Full</b>	Displays a picture that is stretched out of proportion to fill the screen.
<b>Unscaled</b>	Displays a picture at its original size.
<b>4:3</b>	Displays a 4:3 picture at its original size. Sidebars appear on both edges of the screen.
<b>Movie expand</b>	Displays a American vista 16:9 picture at its original size.

## TV screen information

You can display the currently selected channel or other information

1 Press  (INFO).



## Using options menu

You can access to some TV settings directly by using  (OPTIONS).

1 Press  (OPTIONS) to display options menu, then press OK



2 Use     to select a desired setting, then press OK.

## Useful tips

### FAQ

#### **My remote does not work. What should I do?**

- Check the antenna or cable connection to the main unit.
- Check the batteries on the remote.
- Check if there is an obstacle between the infrared sensor window and the remote.
- Test the IR signal output use IR signal check. If okay, then possible infrared sensor trouble.
- Aim the remote directly at the infrared sensor window on the front of the unit.
- Reduce the distance to the unit.
- Re-insert or replace the AAA batteries with their polarities (+/–) as indicated on the remote battery area.
- When there is an infrared-equipped device such as PC near this unit, it may interrupt the remote signal on this unit. Move the infrared-equipped device away from this unit, change the angle of the device's infrared sensor or turn off the infrared communication function.

#### **How come the initial setup appears every time I turn on this unit?**

- Make sure to complete the initial setup before the unit goes into standby mode.

#### **Why can I not watch some RF signal TV programs?**

- The selected channel may not be broadcasting.
- The selected channel cannot be viewed by the Parental Controls setting.
- The unit requires some kind of antenna input. An indoor antenna (Digital or VHF / UHF), an external antenna (Digital or VHF / UHF) or an RF coaxial cable from your wall cable or set-top box needs to be plugged into the unit.

#### **How come there is no image from the connected external devices?**

- Check if the correct input is selected by pressing  (INPUT).
- Check the antenna, cable or other input connection to the unit.

#### **When I enter a channel number, why does it change automatically?**

- Many digital channels have alternate channel numbers. The unit changes the numbers automatically to the ones signifying the broadcasting station's channel number. These basic numbers used for the previous analog broadcasts. (e.g., input digital ch# 30 automatically changes to digital ch# 8.1)

## **Why are captions not displayed entirely? Or why are captions delayed behind the dialog?**

- Closed captions that are delayed a few seconds behind the actual dialog are common for live broadcasts. Most captioning production companies can display a dialog to maximum of 220 words per minute. If a dialog exceeds that rate, selective editing is used to insure that the closed captions remain up-to date with the current TV screen dialog.

## **How can I set the clock?**

- From the Android TV home screen, select Settings in the upper right of the screen. Scroll down to Device Preferences and select Date & time. Please set it automatically or manually.

## **Troubleshooting tips**

If the unit does not perform properly when operated as instructed in this manual,

Please check the following Troubleshooting tips and all connections once before calling for service.

### **Power**

#### **No power**

- Make sure the AC power cord is plugged in.
- Make sure that the AC outlet supplies the proper voltage, plug another electrical appliance into the AC outlet to ensure that the AC outlet operates normally.
- If a power failure occurs, unplug the AC power cord for 1 minute to allow the unit to reset itself.

### **Remote**

#### **Control buttons do not work.**

- Do NOT press more than one button at the same time.
- Ensure that no buttons on the remote are depressed and move freely.
- Re-insert or replace the AAA batteries with their polarities (+/-) as indicated on the remote battery area.

#### **Universal remote does not work properly.**

- Refer to the user manual of the universal remote for the Philips code.

#### **The Google Assistant microphone on the remote does not work.**

- To pair the remote, refer to the step “6 Connecting your devices” in the Quick start guide and see “How to connect to your Bluetooth® devices”.

## Performance

### Remote response is delayed or sluggish during initial use.

- Your television is automatically, downloading and installing the latest applications, for the best user experience.
- During this time, you may experience a delayed response from your remote. Upon successful installation, your remote will operate normally.

## Accessibility

### Television is speaking prompts out-loud.

- To enable or disable the talkback (text to speech) on your television, press  (HOME) on your remote, navigate to settings (found in the upper right corner of the home screen) and select accessibility, select talkback, press OK to toggle between on or off.

## Picture

### Power is on but screen image is off.

- Check if the connection for your source device is properly secured.
- Check if the correct input is selected by pressing  (INPUT).
- Verify that your HDMI mode, for the input selected matches the resolution output of your source device. Change source input until you have picture and sound.

## Sound

### No sound is heard when using the HDMI digital connection.

- Some HDMI cables and devices may not be compatible with the TV due to different HDMI specifications.

### No sound, distorted sound or incorrect audio sound is heard when using the HDMI-DVI connections.

- Make sure that the analog audio signals from the HDMI-DVI device are connected to the analog audio input L/R jacks.
- When using Composite analog video, make sure that the analog audio (L/R) connectors are mounted into the audio (L/R) input jacks.

### No sound from Soundbar / Home theater using an HDMI cable.

- Please check to be sure the device is connected to the HDMI 2 (ARC) input on the TV.

### Sound intermittent or no sound.

- Check if the audio cable is connected into the unit correctly.

### **You switch to a different input and the volume changes.**



- This unit will memorize the volume level from the last time you adjusted it.
- If the volume of the sound from another device is higher or lower, then the loudness will change.
- Make sure Auto Volume Control is set to On.

## **Picture & Sound**

### **No sound with distorted picture occurs when using the HDMI digital connection.**

- Some HDMI cables and devices may not be compatible with the TV due to different HDMI specifications.

### **No picture or sound**

- Check if the power is on.
- Check whether all the cables to the unit are connected to the correct output jack on your separate device like Blu-ray Disc™ / DVD recorder.
- View other TV channels. The problem might be limited to the broadcasting station or weak signal strength.
- Unplug the AC power cord and wait for about 1 minute, then plug the AC power cord and turn on the unit again.
- Check whether the connection of the antenna or cable / satellite set-top box is connected correctly.
- Make sure that the selected input mode is connected to the working input jack.
- Make sure that the sound is not muted. Press  (MUTE) so that the volume bar and current volume level will appear on the TV screen.
- Make sure that the volume is NOT set to 0 or  (MUTE). If so, use VOL + / – to adjust to the desired volume.
- Make sure that the headphone is NOT connected to the headphone audio output jack.
- If there are issues with picture/color and/or sound when connecting an external device using the HDMI port, please try switching the HDMI EDID Version. (Refer to HDMI EDID Version)

### **Adjusted Picture or Sound settings are not effective every time the unit is turned on.**

- You need to turn off the Retail Mode setting. (Otherwise, the settings you adjusted will not be memorized after the unit goes into standby mode.)

### **You see a distorted picture or hear an unusual sound. (Analog TV - NTSC signal)**

- You may be getting NTSC (Analog) TV signal (not HDTV signal) interference from electrical appliances, automobiles, motorcycles or fluorescent lights.

- Try moving the unit to another location to see if this is the cause of the problem.

### **Ghosts, lines or streaks in picture.**

- Electrical interference from nearby appliances may affect picture quality.
- View other TV channels. The problem might be limited to the broadcasting station or weak signal strength.

### **Picture poor, sound intermittent or no sound**

- View other TV channels. The problem might be limited to the broadcasting station or weak signal strength.

## **Screen**

### **You switch to a different input and the screen size changes.**

- This unit will memorize the viewing mode from the last time you used the particular input modes.

### **The display image does not cover the entire screen.**

- If you are watching TV or using the composite video or HDMI with 480i input, select Picture format, and then switch to various screen modes. (Refer to Picture format )

### **Different color marks on the TV screen**

- View other TV channels. The problem might be limited to the broadcasting station, missing data or pixelation due to weak signal strength

## **Closed captions**

### **Closed captions are displayed as a white box. No closed captions are displayed in the closed captions-supported program.**

- Interference from buildings or weather conditions may cause closed captions to be incomplete if watching analog TV signals.
- Broadcasting station may shorten the program to insert advertisements. The closed caption decoder cannot read the information of the shortened program.

### **Black box is displayed on the TV screen.**

- The text mode is selected for caption. Select CC-1, CC-2, CC-3 or CC-4.

## **Software update**

### **A message appears on the screen prompting for software update again.**

- When you start up the TV or a net service after executing the software update, a message may appear on the screen prompting for software update again. In this case,

please execute the software update. (start from Settings > Device Preferences > About > System update)

## **Network**

### **Cannot connect to the network.**

- Check if the broadband router and/or modem is correctly connected.
- Check if the Ethernet cable connection is properly made. Turn on the broadband router and/or modem.
- Check the network settings.

### **Sometimes video quality is poor when using the wireless LAN.**

- The wireless network connection quality varies depending on the distance or obstacles (e.g. wall, basement, 2nd floor) between the TV wireless LAN adapter and the wireless router (access point), from other wireless networks, and brand and type of the wireless router (access point). When using the wireless LAN of the TV, it is suggested to place the wireless router as close as possible to the television.

### **Wireless LAN connection fails or wireless connection is poor.**

- Check the installation location of the TV and wireless router (access point). Signal quality may be affected for the following reasons.
  - Interference of other wireless devices, microwaves, fluorescent lights, etc., are placed nearby.
  - There are floors or walls between the wireless router and TV.
  - If the problems continue even after checking the above, try making a wired LAN connection.

### **Cannot use the wireless connection.**

- Check if the wireless LAN Access Point (AP) (e.g. wireless router) is oriented properly or not placed too close between them.
- Once you have activated the wireless connection please wait 30 seconds for the connection to be established after turning on the unit, before trying to access network features.

### **Slow Data Connection or buffering.**

- Check the settings between your router and ISP modem or gateway (if applicable).
- Connect to a stable wireless connection from home wireless or wired network.
- The use of mobile hot spots or public wireless connections is not recommended.

### **Cannot use Netflix feature.**

- Check if the network connection is properly made.

- Visit netflix.com on your PC and become a Netflix member.
- Some network services may not be available in your country.

**Cannot add movies or TV episodes to the Instant Queue.**

- Visitnetflix.com on your PC.

**Even though the speed of the internet connection improves during playback, the picture quality of Netflix streaming movie does not improve.**

- The picture quality does not change during playback. It differs depending on the speed of internet connection at the time of loading.

**Cannot use VUDU feature.**

- VUDU is available only in the United States.
- Check if the network connection is properly made.

**Cannot rent or buy movies / TV episodes on VUDU.**

- You need to activate the VUDU account. For detailed information, please visit the service providers website
- Log into your account and check your payment information.

**The picture quality of a streaming movie (Netflix or VUDU) is poor.**

- Check the speed of your internet connection. You need speeds of at least 8 Mbps to this player for high quality uninterrupted playback.

**Streaming movie (Netflix or VUDU) often stops or starts buffering during playback.**

- Contact your internet service provider to troubleshoot your internet connection for speed and line quality. Consistent line quality and speed are very important for internet video playback.

**Cannot connect to the network while my PC is connected to the network.**

- Check the content of your internet service contract to see if your internet service provider prevents multiple terminals connecting at the same time.

**Folder or files stored on home network media server are not displayed in the file list or cannot be played back.**

- Check the setting on your home media server. (Refer to the user manual of the home media server.)
- Check the network connection and settings

# Specifications

Model #		43PFL5604
<b>Picture</b>		
Type	UHD (Ultra HD) (3840 x 2160 pixels 60 Hz)	
Diagonal screen size / Aspect ratio	42.5" / 16:9	
Viewing angles	178° (V) by 178° (H)	
Built-in digital / analog tuner	ATSC (digital) / NTSC (analog)	
<b>Sound</b>		
Mono / Stereo	Mono, Stereo	
Power output (RMS watts)	8 W x 2	
Equalizer	5 band	
<b>Ease of use</b>		
Picture format	SD (4:3 source)	Automatic / Full / Unscaled / 4:3 / Movie expand
	HD (16:9 source)	
	UHD	
<b>Channel</b>		
Channel coverage	Over-the-Air DTV (ATSC)	VHF: 2~13 UHF: 14~69 (Each channel may have e.g. 21~29, 31~39, etc)
	Over-the-Air Analog (NTSC)	VHF: 2~13 UHF: 14~69
CATV (Analog NTSC)	2~13, A~W W+1~W+94 (Analog W+1~W+84), A-5~A-1, 5A	
Tuning system	Channel frequency synthesized tuning system	
Channel access	Direct access number keyboard, Programmable scan and Channel + (up) / - (down)	
<b>Connectivity</b>		
Composite video input	1	
HDMI input	3 (selectable HDMI modes)	
	Supporting HDMI video signals : 480i/p, 720p, 1080i @60 Hz, 1080p, 2160p @24/30/60 Hz	
	Supporting HDMI HDR signals : HDR10	
	Supporting HDMI digital audio signals : LPCM, AC3, DD+	
	Supporting PC-input video signal up to 4096 x 2160	
Analog audio L/R input	1 (L audio / R audio)	
PC input	Via HDMI and HDMI-DVI + Analog audio L/R	
USB	1	
Wireless LAN	Wireless LAN Supporting wireless standards : IEEE 802.11a/b/g/n/ac (2.4 GHz/5 GHz)	
Ethernet port	1	
Digital audio output	1 Supporting Dolby Digital	
Headphone output	1 1/8" (3.5 mm)	
<b>Power</b>		
Power requirements	120 V~ +/- 10%, 60 Hz +/- 0.5%	
<b>Temperature</b>		
Operating temperature	41 °F (5 °C) to 104 °F (40 °C)	

• Specifications are subject to change without prior notice.

## Warning

This content is compiled from multiple sources and is provided for reference purposes only. It may not be complete or fully applicable to all situations. If you are unable to resolve your issue, please contact the product manufacturer or an authorized service provider for official support.