

AUTOMATIC ICE & WATER DISPENSER

Ice maker/dispenser tips

- If your refrigerator is not connected to a water supply or the water supply is turned off, turn off the ice maker as described in the previous section.
- The following sounds are normal when the ice maker is operating:
 - Motor running
 - Ice dropping into ice bin
 - Water valve opening or closing
 - Running water
- If you need a large quantity of ice at one time, it is best to get cubes directly from the ice bin.
- Ice cubes stored too long may develop an odd flavor. Empty the ice bin as explained below.
- When dispensing cubed ice, it is normal to have a small quantity of little pieces along with the whole cubes.
- To avoid splashing, dispense ice into your container before adding liquids.
- It is normal for ice to fill to the top of the ice bin.



CAUTION

If the water supply to your refrigerator is softened, be sure the softener is properly maintained. Chemicals from a water softener can damage the ice maker

Cleaning the ice maker

Clean the ice maker and ice bin at regular intervals, especially prior to vacation or moving.

1. Turn off the ice maker.
2. Remove the ice bin by pulling straight out.

3. Empty and carefully clean the ice bin with mild detergent. Do not use harsh or abrasive cleaners. Rinse with clear water.

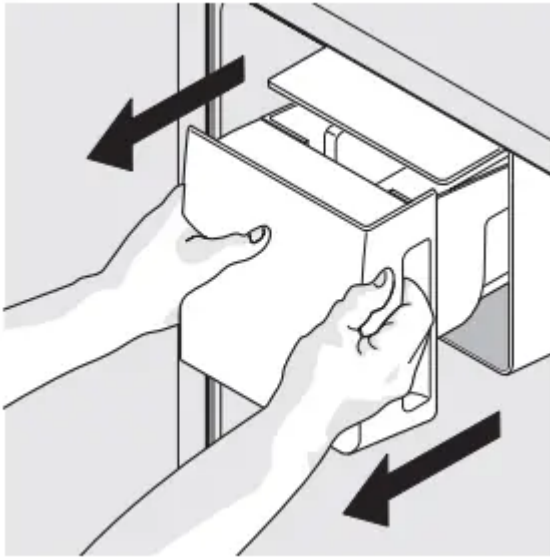

4. Allow the ice bin to dry completely before replacing in the freezer.
5. Replace the ice bin. Turn the ice maker on.

Remove and empty the ice bin if:

- An extended power failure (one hour or longer) causes ice cubes in the ice bin to melt and refreeze together after power is restored, jamming the dispenser mechanism.
- You do not use the ice dispenser frequently. Ice cubes will freeze together in the bin, jamming the dispenser mechanism.

Remove the ice bin and shake to loosen the cubes or clean as explained above.

CAUTION NEVER

use an ice pick or similar sharp instrument to break up the ice. This could damage the ice bin and dispenser mechanism.

To loosen stuck ice, use warm water. Before replacing the ice bin, make sure it is completely dry



IMPORTANT

When removing or replacing the ice bin, avoid rotating the auger in the ice bin. If the auger is accidentally rotated, you must realign the auger by turning it in 45 degree turns (see below) until the ice bin fits into place with the drive mechanism. If the auger is not properly aligned when replacing the ice bin, the refrigerator will not dispense ice. The fresh food door also may not close

properly causing warm air to leak into the fresh food compartment.

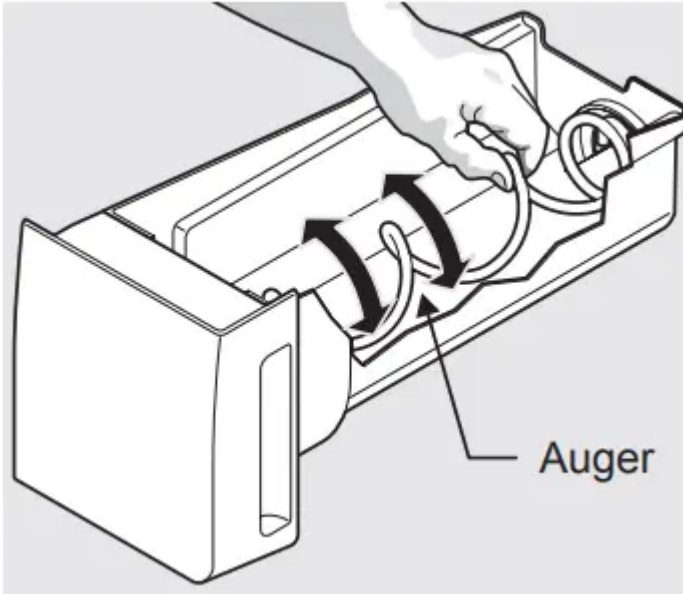

STORAGE FEATURES

CAUTION

To avoid personal injury or property damage, handle tempered glass shelves carefully. Shelves may break suddenly if nicked, scratched, or exposed to sudden temperature change. Allow the glass shelves to stabilize to room temperature before cleaning. Do not wash in dishwasher.

NOTE

Features may vary according to mode

Your refrigerator includes SpillSafe™ glass shelves that are designed to catch and hold accidental spills.

You can easily adjust shelf positions in the fresh food compartments to suit your needs. The shelves have mounting brackets that attach to slotted supports at the rear of each compartment

Change the Position of a Shelf

1. Remove all food from shelf.
2. Lift the front edge up and pull the shelf out.
3. Replace by inserting the mounting bracket hooks into the desired support slots.
4. Lower the shelf and lock into position.



IMPORTANT

Be aware of the air seal located at the rear of the shelf. Shelves located on the left side should have the air seal mounted on the far left side. Shelves located on the right side should have the air

seal mounted on the far right side. This is to ensure there is no interference with the large air tower on the back wall of the cabinet. This also applies to the crisper shelves.

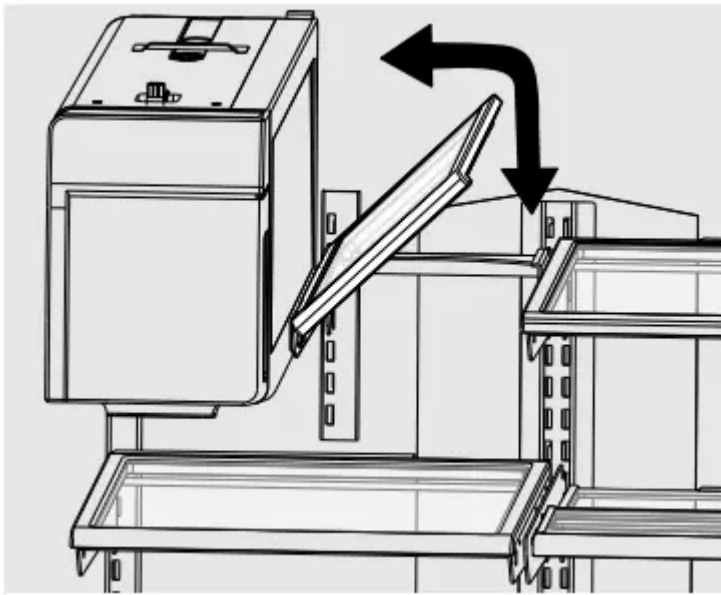

Flip Shelf

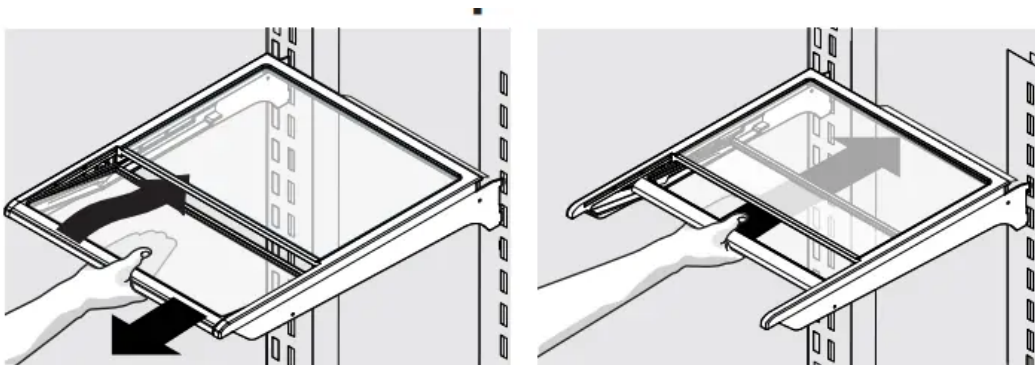

Slide-Under Shelf (varies by model)

Reposition the Air Seal

For slide-out shelves & crisper shelves:

1. Remove air seal by pushing down on the flap with a downward rotation.
2. Position the air seal towards the outside end of the shelf to avoid the air tower when shelf is pushed back into place.
3. Install seal by sliding lower tab of seal up into bottom rear slot of shelf with seal at a downward angle then pulling up on seal flap until seal sits snug on back of shelf and flap sits at about a 10 degree angle from shelf surface.

For slide-under shelves:

1. Remove air seal by pushing seal straight back.

2. Position the air seal towards the outside edge of the shelf to avoid the air tower when shelf is pushed back into place.
- 3 Install seal by sliding the open channel end of the seal onto back edge of shelf until seal sits snug on back of shelf and flap sits at about a 10 degree angle from shelf surface.

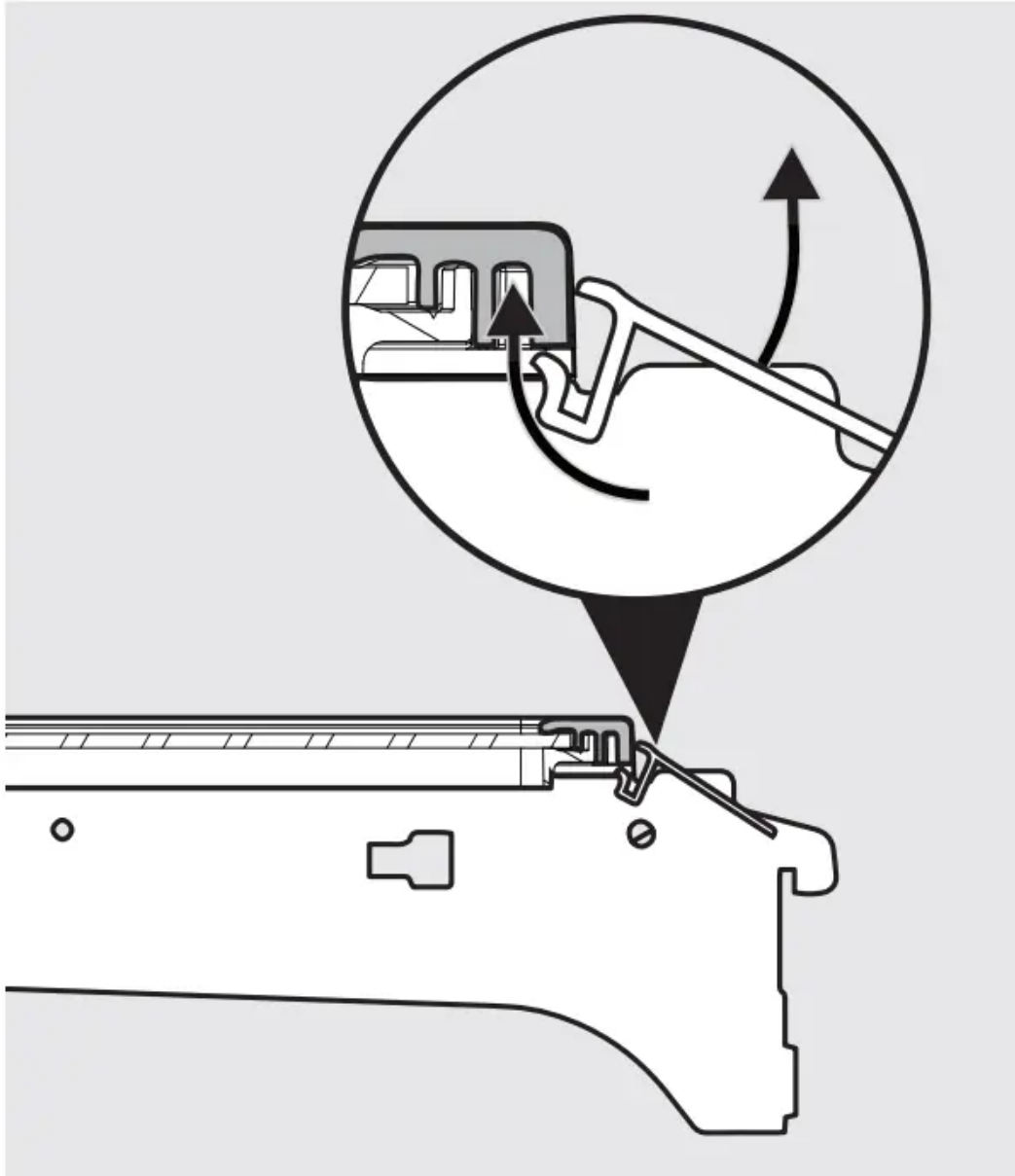

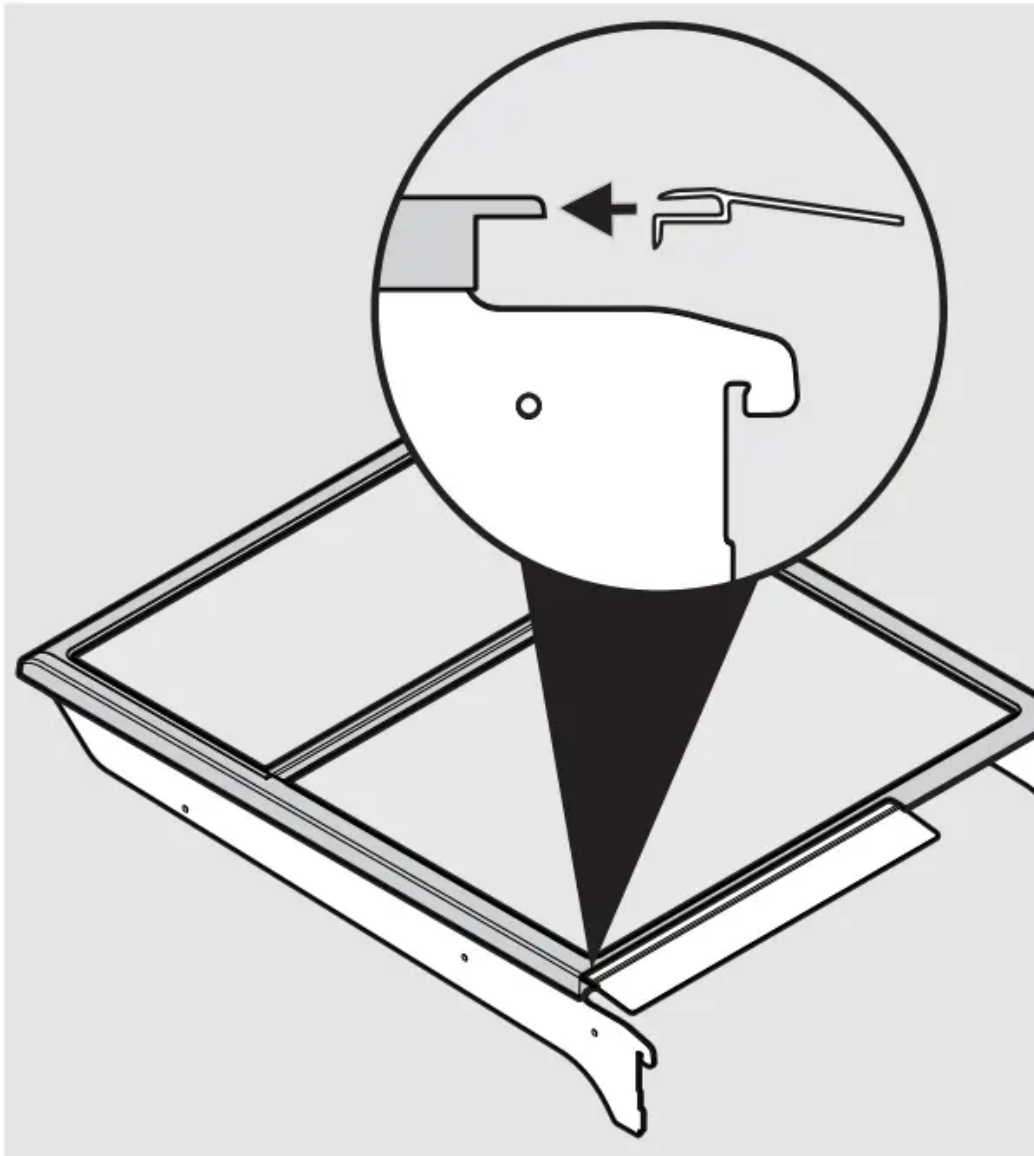

Drawers

Your refrigerator includes a variety of storage drawers.

Crispers

Crisper drawers are designed for storing fruits, vegetables, and other fresh produce.

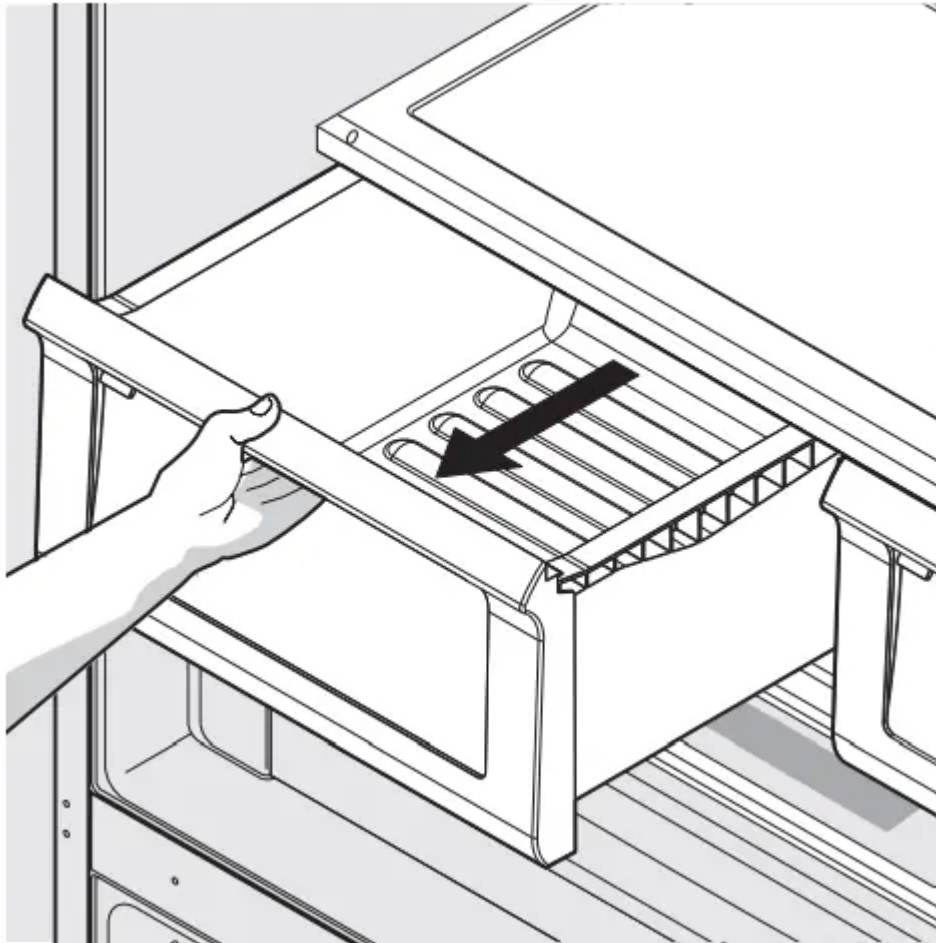

Opening Crisper Drawer

Crisper humidity control

Crisper drawers include a sliding control for adjusting the humidity inside the crisper. Leafy vegetables keep best when stored with the Humidity Control set on Higher Humidity. Fresh fruits keep best when stored with the Humidity Control set on Lower Humidity.

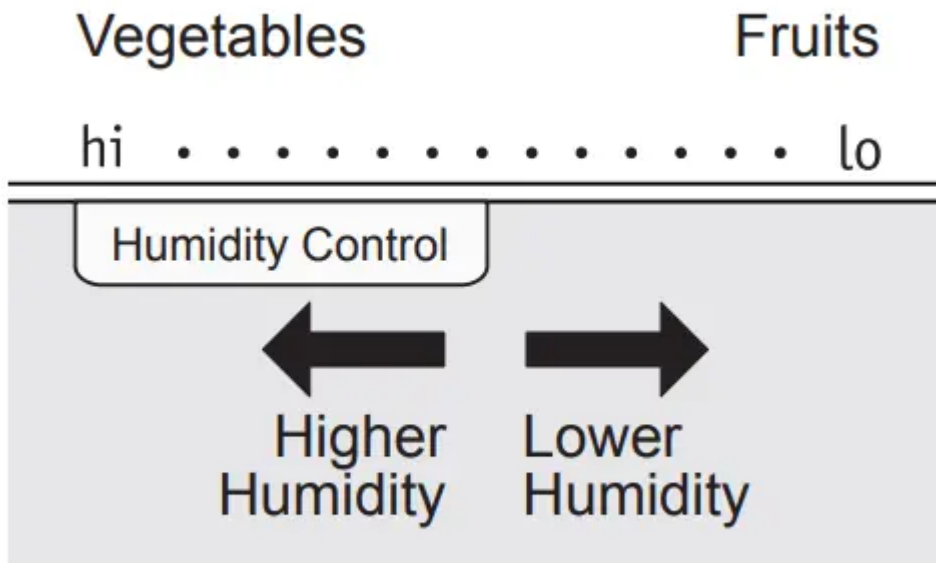

Adjusting Crisper Humidity

To remove the Crisper Drawer for cleaning:

1. Pull the drawer out until it stops.
2. Lift the front slightly and remove the drawer.

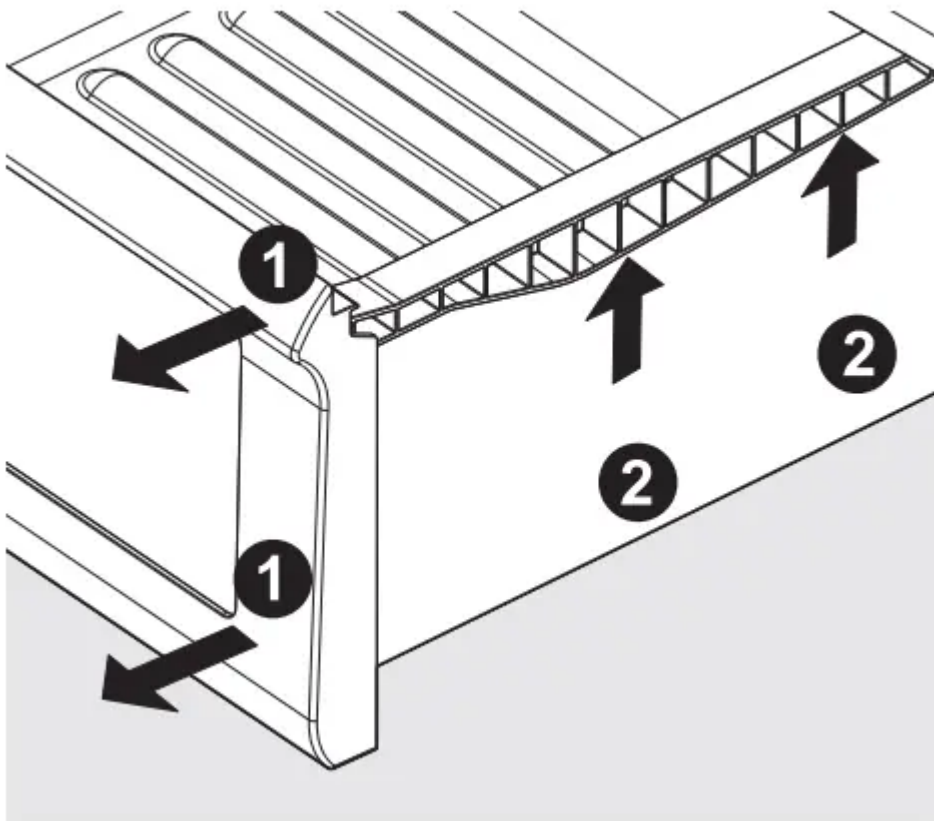

Removing Crisper Drawer



Deli drawer

Ideal for storage of deli meats and cheese

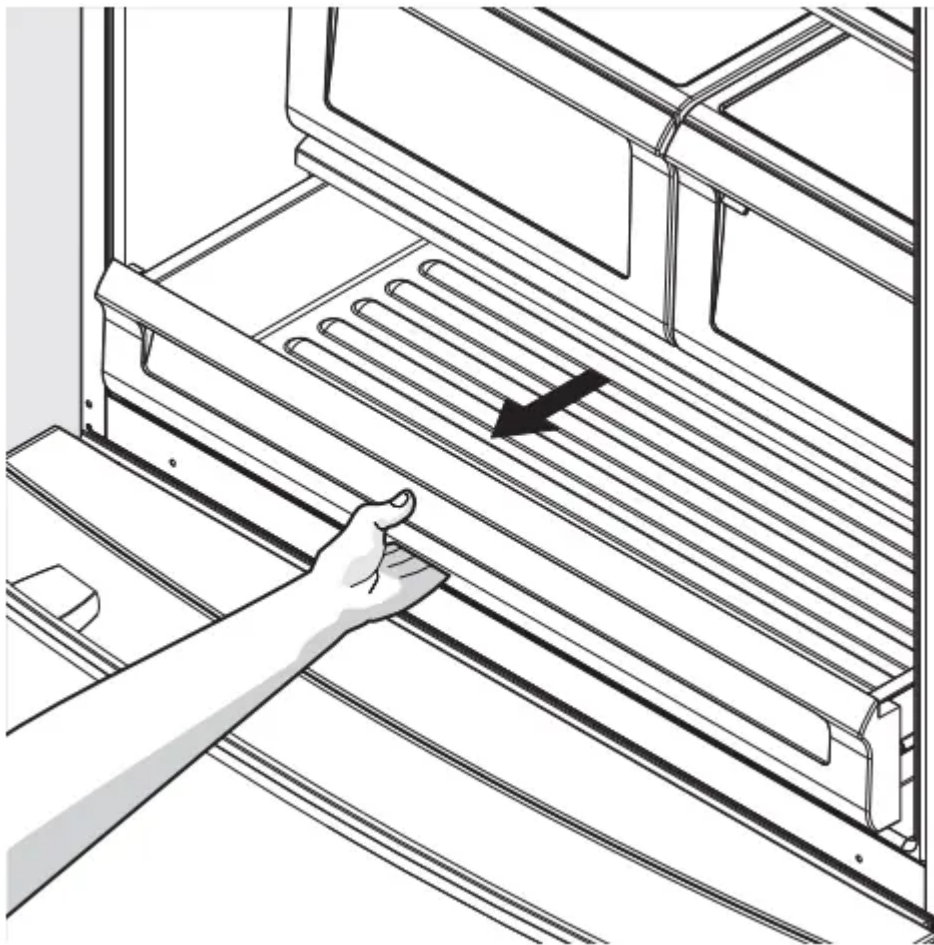

Doors

Storage bins (varies by model)

The doors to your fresh food compartment use a system of modular storage bins. All of these bins are removable for easy cleaning. Some of them have fixed positions, while others can be adjusted to your needs. Door bins are ideal for storing jars, bottles, cans, and large drink containers. They also enable quick selection of frequently used items.

To change the position of an adjustable door bin:

1. Remove all food from door bin.
2. Grip the bin firmly with both hands and lift it upward.
3. Remove the bin.
4. Place the bin just above desired position

5. Lower the bin onto supports until locked in place.
Adjustable Door Bin

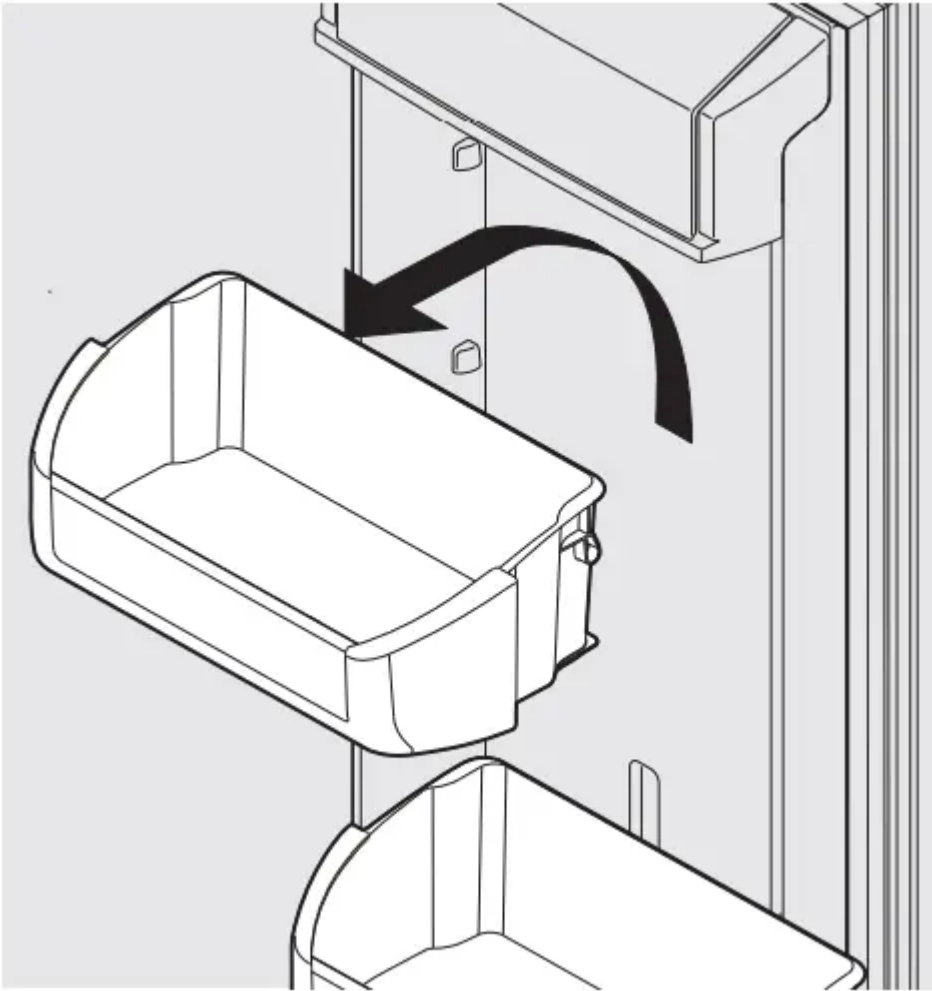

6. Place bin liner into bin

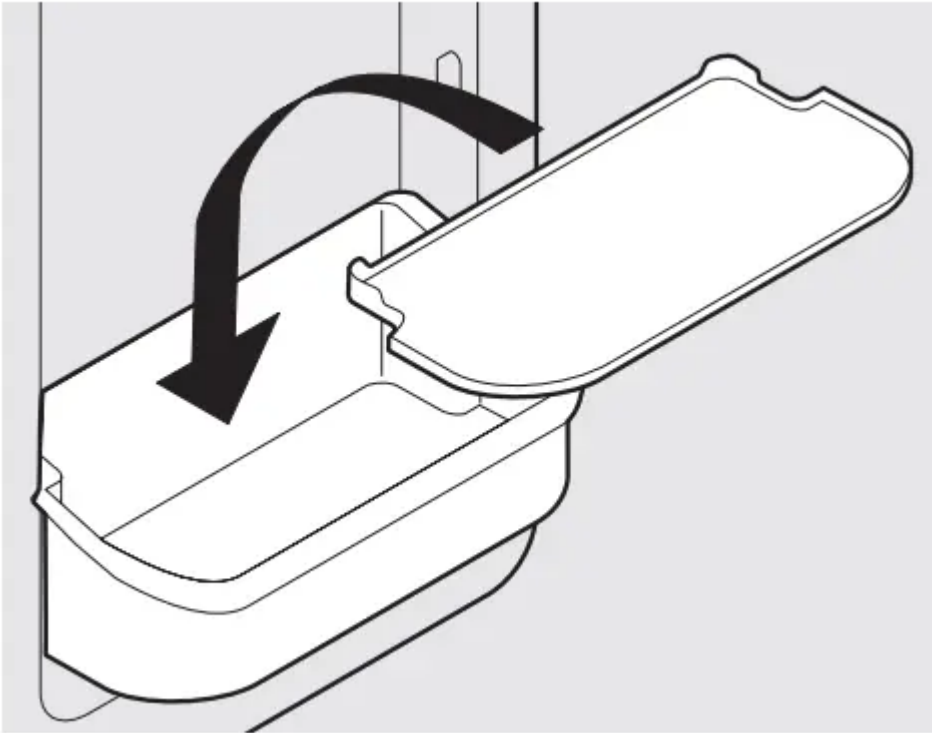

Accessories (varies by model)

Removable Can Dispenser

The can dispenser holds six (12 ounce) cans. Insert cans into top of bin and dispense from the bottom.

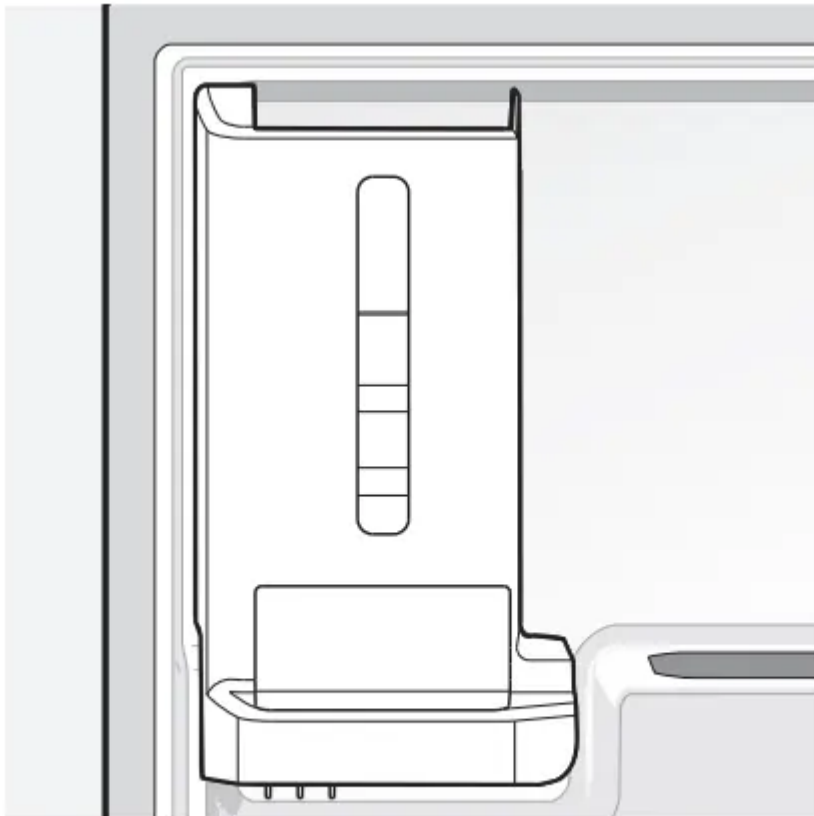

Can Dispenser

Dairy compartment

Use the dairy compartment, at the top of the fresh food compartment door, for shortterm storage of cheese, spreads, or butter. The dairy compartment is designed to be warmer than the open area

and includes a lift-up cover and a dairy divider (select models).

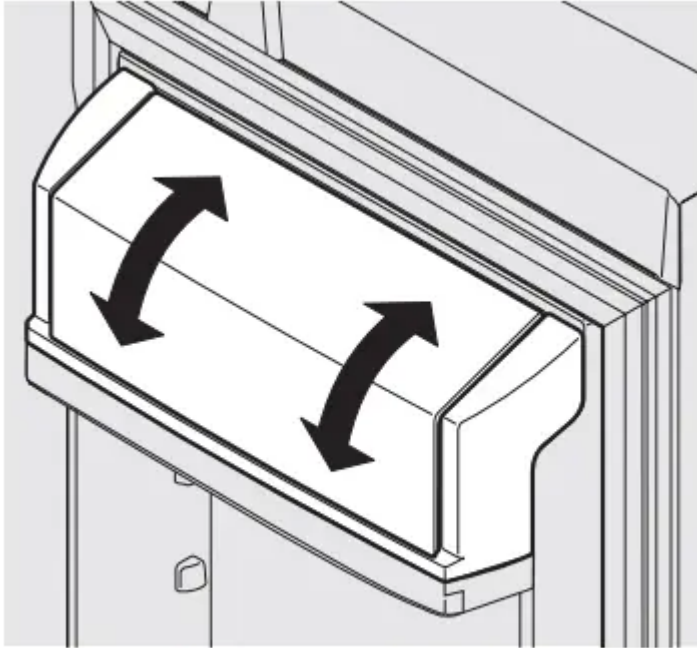

Dairy Compartment

Freezer Features (varies by model)

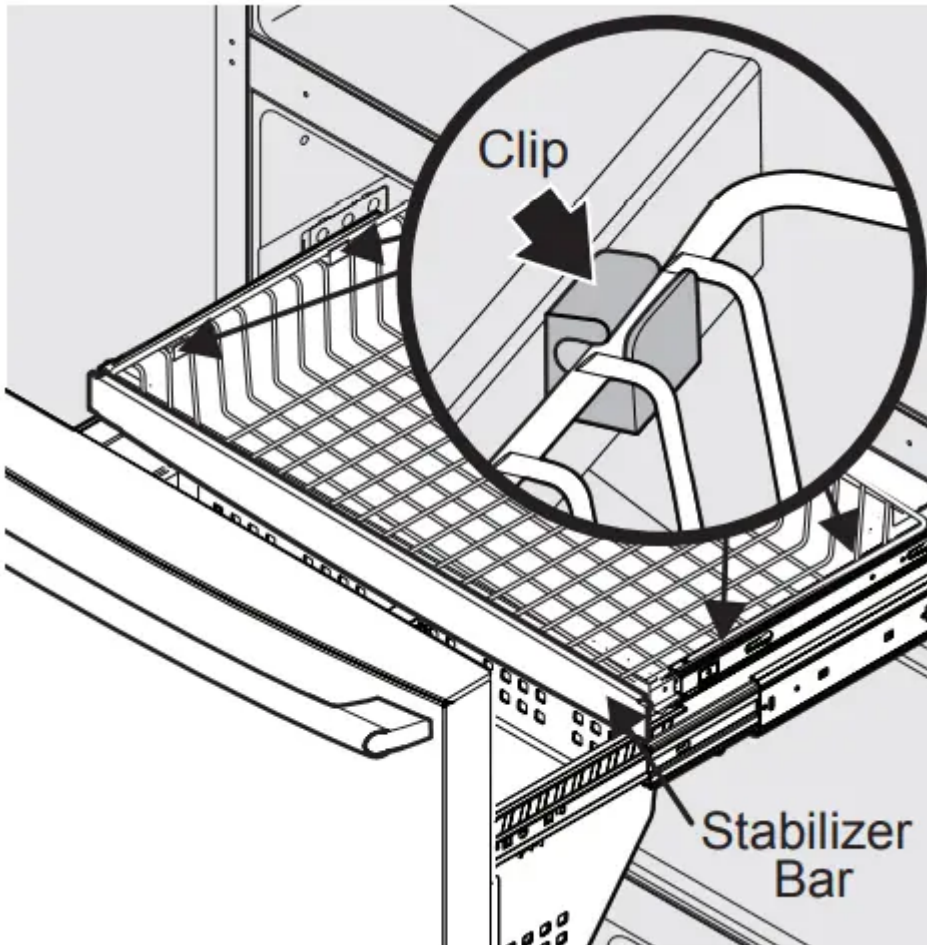

To Remove Upper Freezer Basket

1. Find the side where the basket frame is aligned to the clip opening. The basket frame should be aligned to both front and rear clips on the same side (either left or right side).
2. If the basket frame is not aligned to the left or right side, push the basket sideways (to either side) until it is aligned.
3. By grabbing the basket wire frame close to the frontal clip, pull up to take the basket frame out.
4. Grab the basket frame close to the rear clip and pull up until it comes out of the clip.
5. Once one side of the basket is off the clips or retainers, slide the basket sideways until the other side of the frame is aligned with the clip openings on the opposite side of the freezer.
6. In the same way, pull up the basket frame from the frontal and rear clips until it is out of the clips.
7. Remove the basket.

Reverse the steps to reinstall the basket.

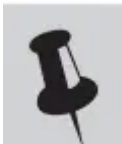

NOTE

If basket is not resting on stabilizer bar retainer clips, the drawer will not close properly.

Removing Freezer Basket Instructions

1. Locate the basket clips in the rear corners of the basket and pull them out to remove.
2. Open fresh food doors completely.
3. Lift the basket up and remove.

Replacing Freezer Basket Instructions

1. Place freezer basket back inside the freezer drawer.
2. Replace clips by sliding them back into the slots.

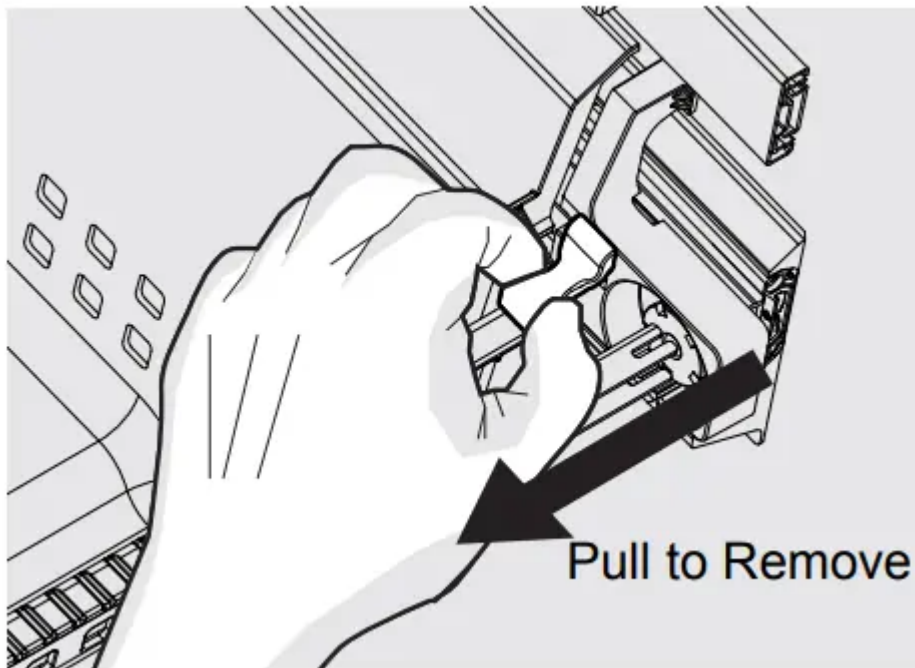
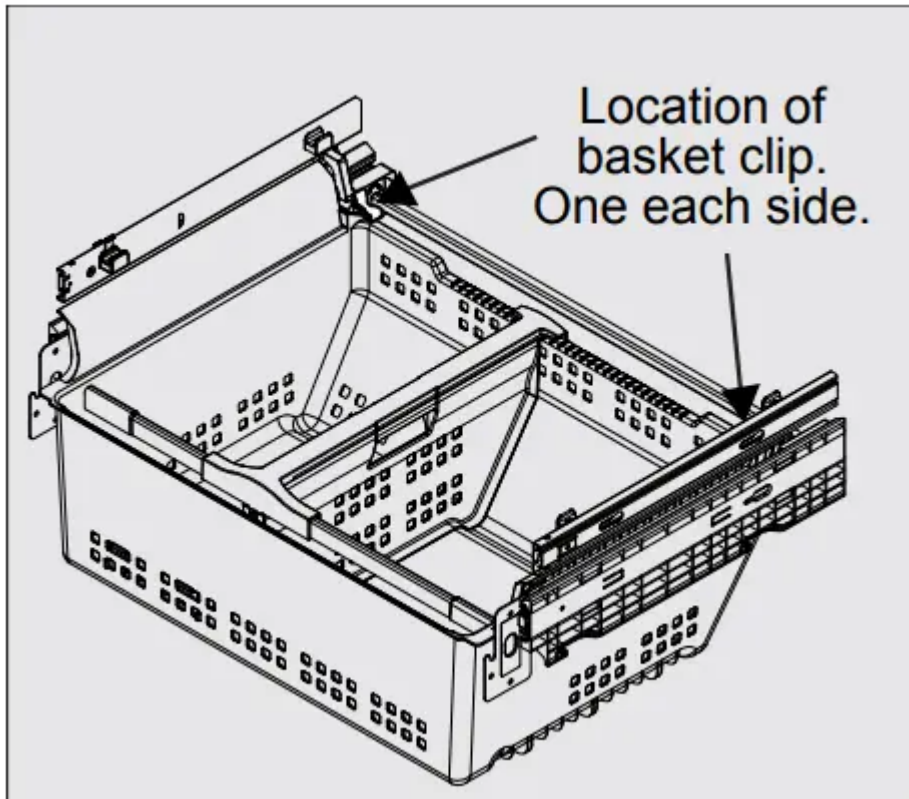

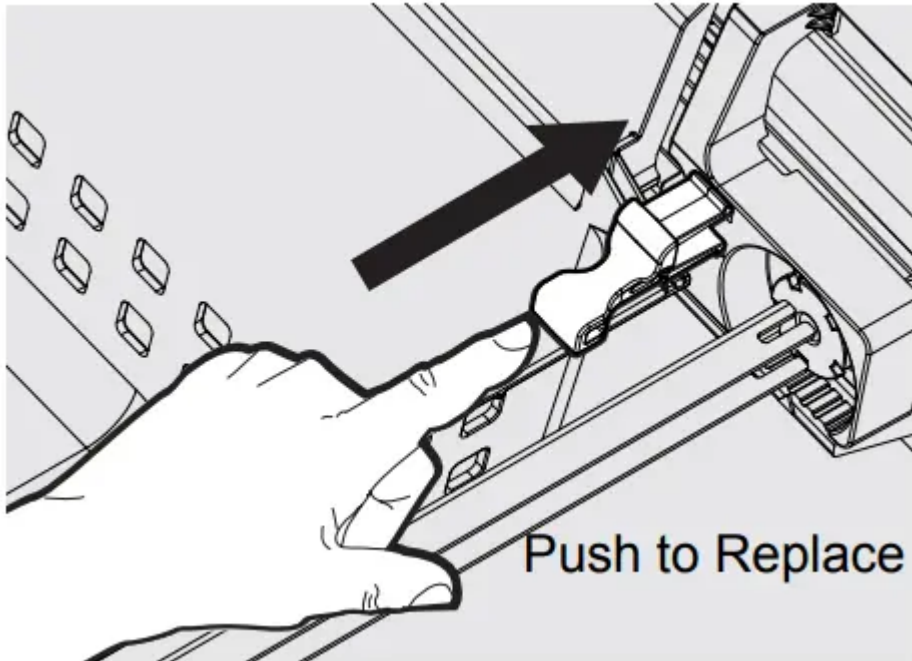

Dividers Removal

Lift up on the front of the upper divider and pull out.

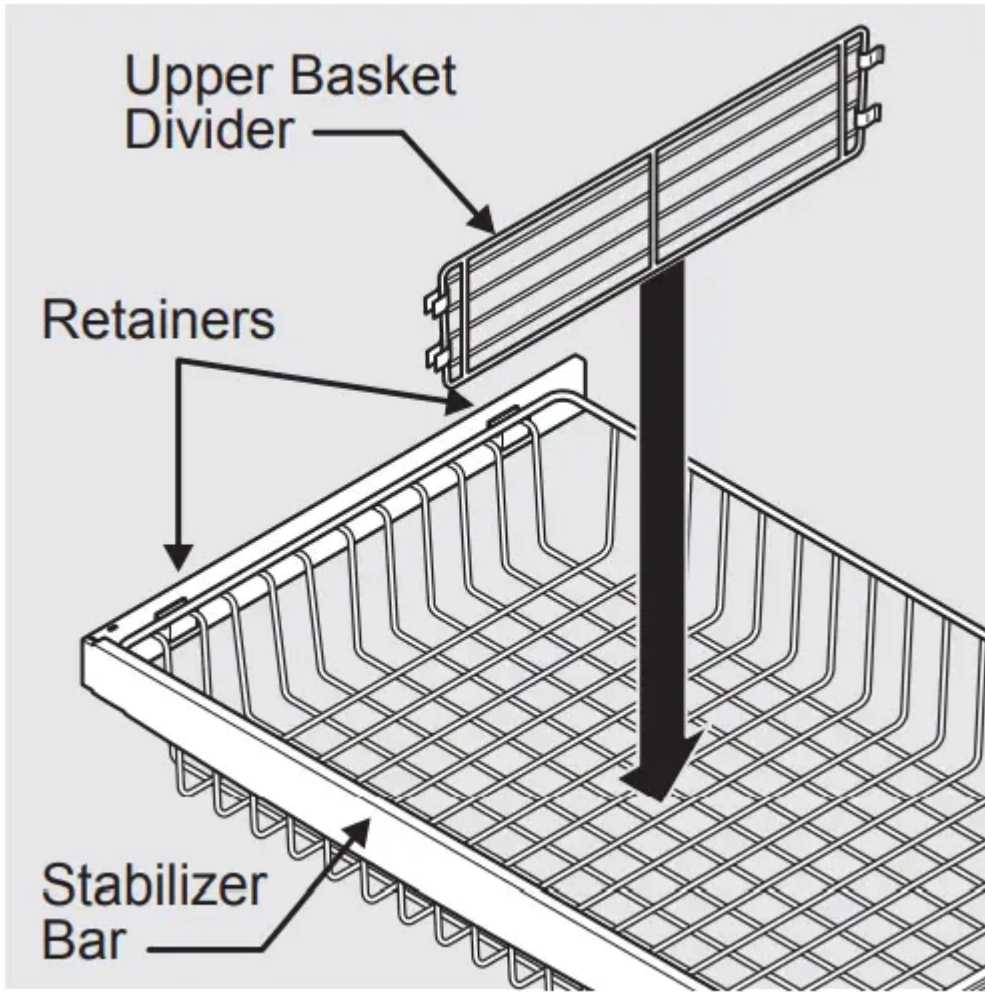

Upper Basket Divider

Squeeze handle and lift up in the center of the divider to move it side-to-side. (The divider cannot be removed.)



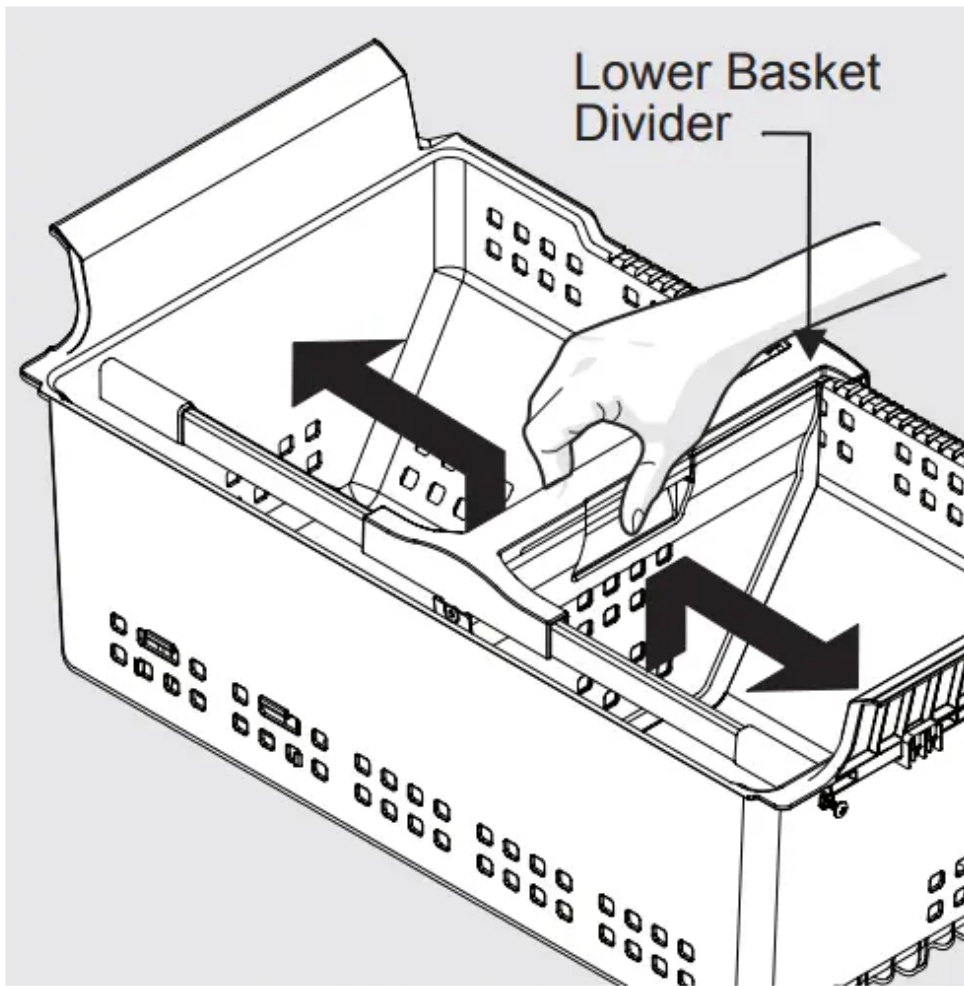

Plastic Lower Basket Divider

Tilt Wire Shelf

The freezer tilt wire shelf (located on the inside of the freezer drawer) is not designed to be removed.

NORMAL OPERATING SOUNDS AND SIGHTS

Understanding the sounds you may hear

Your new, high-efficiency refrigerator may introduce unfamiliar sounds. These sounds normally indicate your refrigerator is operating correctly. Some surfaces on floors, walls, and kitchen cabinets may make these sounds more noticeable.

The following is a list of major components in your refrigerator and the sounds they can cause:

- A. Evaporator Refrigerant through the evaporator may create a boiling or gurgling sound.
- B. Evaporator fan You may hear air being forced through the refrigerator by the evaporator fan.

- C. Defrost heater During defrost cycles, water dripping onto the defrost heater may cause a hissing or sizzling sound. After defrosting, a popping sound may occur.
- D. Automatic ice maker When ice has been produced, you will hear ice cubes falling into the ice bin. Ice maker fan, water valve activation, and refrigerant gas fluid may create sounds from its operation.
- E. Electronic control & automatic defrost control These parts can produce a snapping or clicking sound when turning the cooling system on and off.
- F. Condenser fan You may hear air being forced through the condenser.
- G. Compressor Modern, high-efficiency compressors run much faster than older models. The compressor may have a highpitched hum or pulsating sound.
- H. Water valve Makes a buzzing sound each time it opens to fill the ice maker.
- I. Drain pan (not removable) You may hear water dripping into the drain pan during the defrost cycle.
- J. Condenser May create minimal sounds from forced air.
- K. Motorized damper May produce a light humming during operation.
- L. Ice dispensing paddle When dispensing ice, you will hear a snapping, clicking, or popping sound.



NOTE

Energy efficient foam in your refrigerator is not a sound insulator.

During automatic defrost cycle, a red glow in the back wall vents of your freezer compartment is normal.

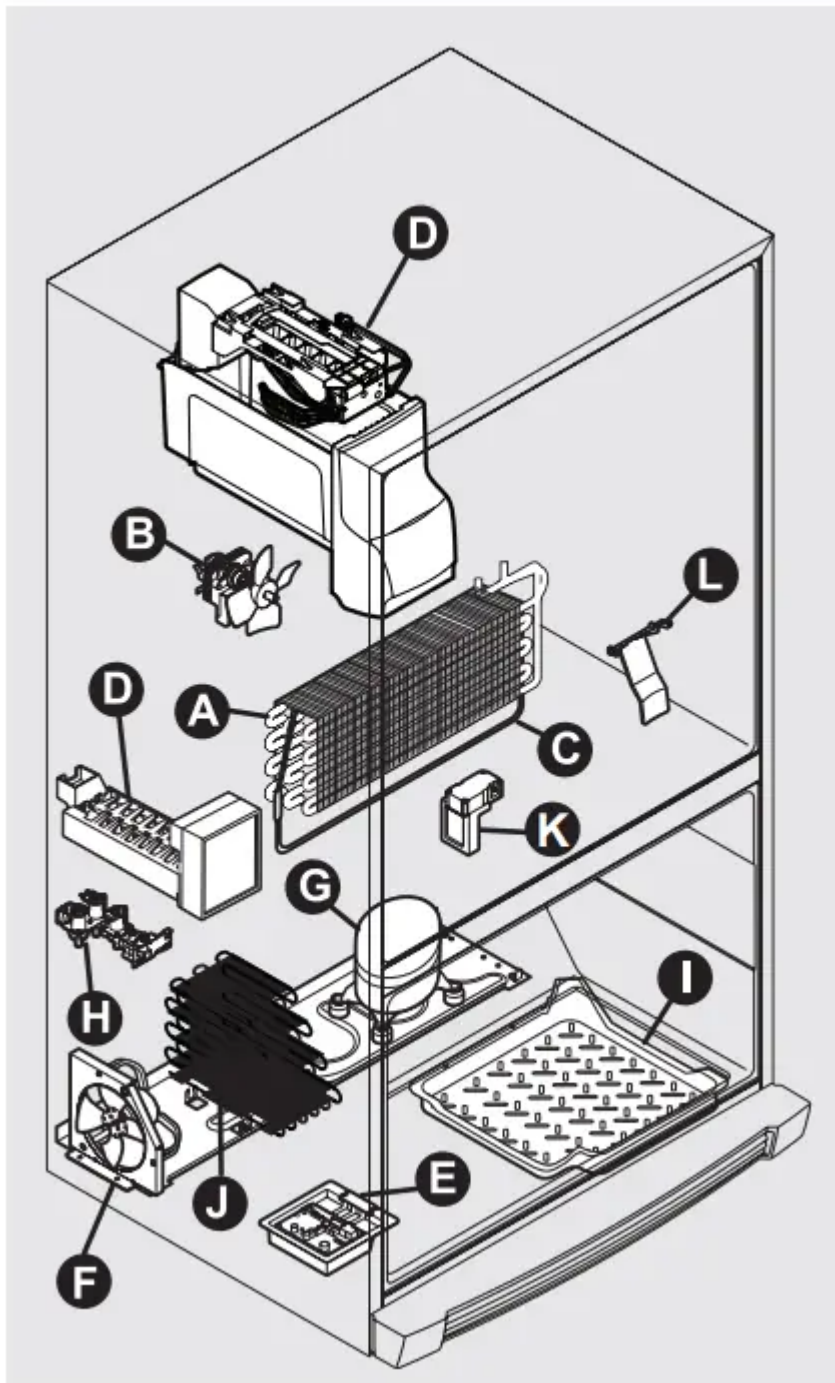

Features vary by model

CHANGING THE FILTER

Air filter (Frigidaire Professional)

The air filter is located under the utility bin

Replacing your PureAir Ultra™ air filter

To ensure optimal filtering of refrigerator odors, you should change the air filter every six months (the filter status light on the Touch Panel prompts you to replace the filter after six months).

1. Open the air filter door.
2. Remove the old filter and discard it.
3. Unpack the new filter and slide it into the housing. The open face of the filter should be installed facing downward.
4. To close the air filter door, push the top and bottom to lock the door closed.
5. Press and hold the Air Filter Reset button on the control panel for three seconds. When the display changes from "Replace" to "Good," the status has been reset.
6. The Air Filter Reset will turn itself off after a few seconds.

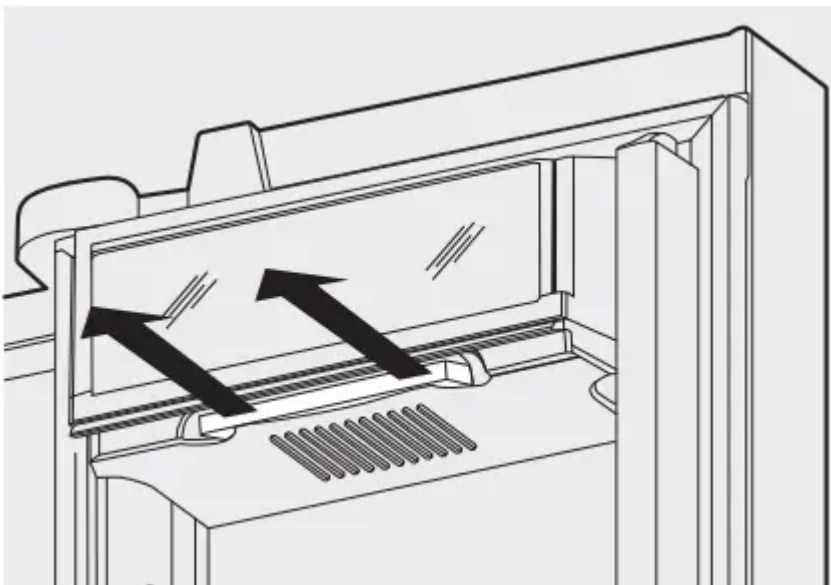
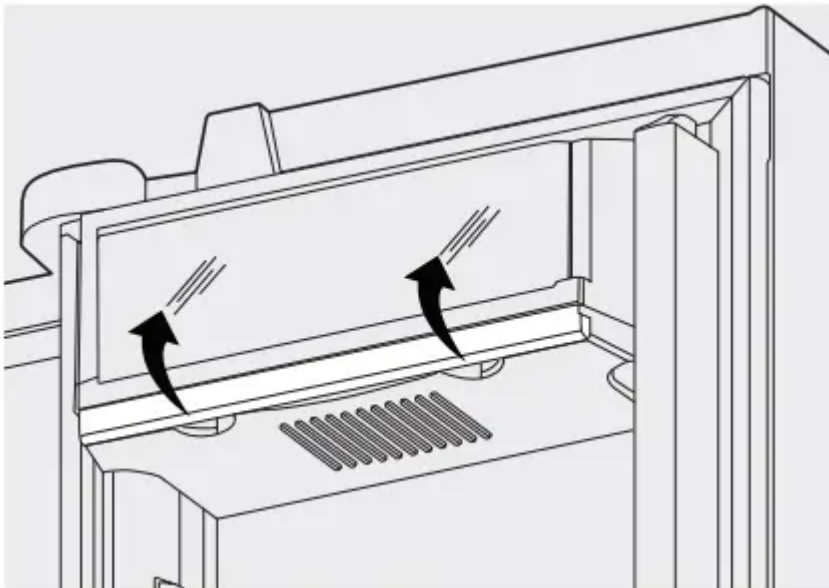

Ordering replacement filters

Order new filters by calling 877-808-4195, online at www.frigidaire.com/store, or through the dealer where you bought your refrigerator. You may want to consider ordering extra filters when you first install your refrigerator.

Air filter (Frigidaire Gallery)

The air filter is located at the top of the air tower.

Replacing your PureAir Ultra IITM air filter

To ensure optimal filtering of refrigerator odors, you should change the air filter every six months (the filter status light on the Touch Panel prompts you to replace the filter after six months).

1. Insert fingers in circled area.
2. Push clips in to release front cover.
3. Remove front cover by pulling towards you and lifting up.
4. Replace air filter by sliding into slots.
5. Installation of front cover is reverse of removal.
6. To reset Air Filter status, refer to instructions under “Controls Section”

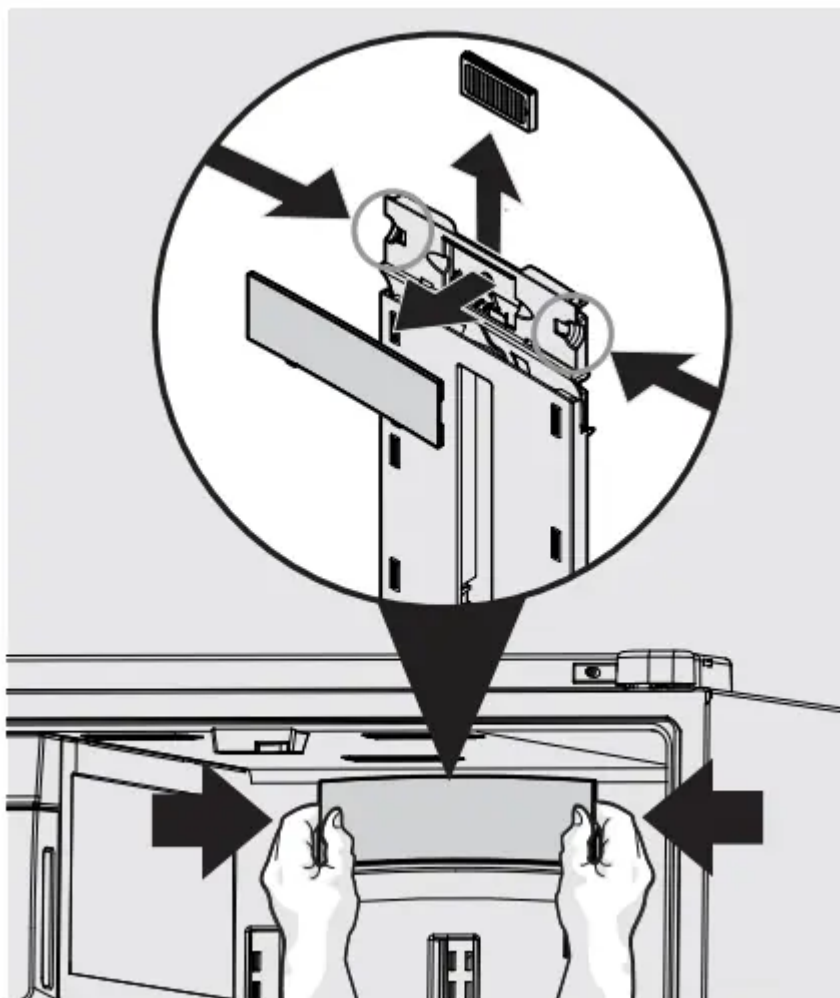

Ordering replacement filters

Order new filters by calling 877-808-4195, online at www.frigidaire.com/store, or through the dealer where you bought your refrigerator. You may want to consider ordering extra filters when you first install your refrigerator.

Locating the Filters

Your refrigerator is equipped with water filtering system. The water filter system filters all dispensed drinking water, as well as the water used to produce ice.

Water Filter

The water filter is located at the top right side of the fresh food compartment.

Replacing the Water

Filter In general, you should change the water filter every six months to ensure the highest possible water quality. Water Filter Status on the user interface prompts you to replace the filter after a standard amount of water (125 gallons/473 liters for PureSource Ultra IITM) has flowed through the system

If your refrigerator has not been used for a period of time (during moving for example), change the filter before reinstalling the refrigerator.

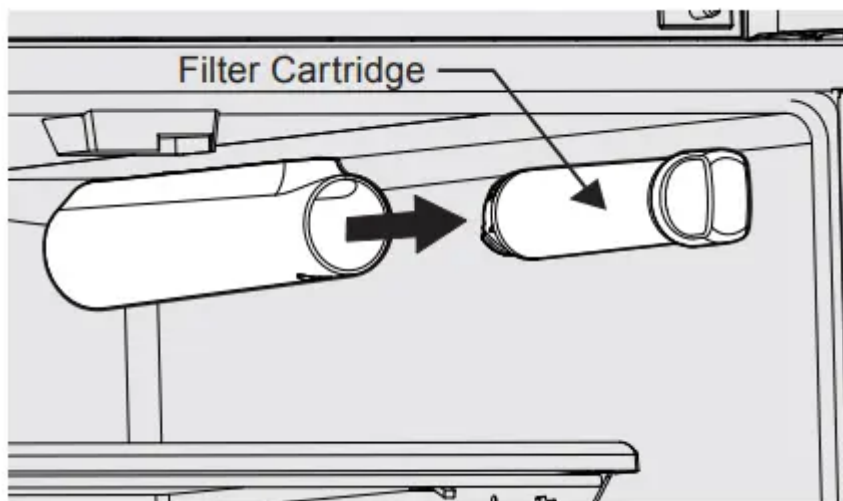

Ordering Replacement Filters

To order your replacement filters, please visit our online store at www.frigidaire.com/store, by calling toll-free at 1-800-599-7569, or by visiting the dealer where you purchased your refrigerator. Frigidaire recommends that you order extra filters when you first install your refrigerator, and that you replace your filters at least once every six months.

NOTE

When ordering your replacement filter, please reorder the same filter type that is currently in your refrigerator.

More about your Advanced Water Filter



The PureSource Ultra IITM ice and water filter system is tested and certified to NSF/ANSI Standards 43, 53 and 401 for the reduction of claims specified on the performance data sheet.

Do not use with water that is microbiologically unsafe or of unknown quality without adequate disinfection before or after the system. Systems certified for cyst reduction may be used on disinfected waters that may contain filterable cysts.

Test & certification results:

- Rated Capacity - 125 gallons/473 liters for PureSource Ultra IITM ice and water filter
- Rated service flow - .65 gallons per minute
- Operating Temp: Min. 33°F, Max. 100°F
- Maximum Rated Pressure - 100 pounds per square inch
- Recommended Minimum Operating Pressure: 30 pounds per square inch

To replace your PureSource Ultra IITM water filter:

It is not necessary to turn the water supply off to change the filter. Be ready to wipe up any small amounts of water released during the filter replacement.

1. Turn Off the ice maker power switch.
2. Remove the old filter by rotating it counterclockwise (to the left) 90 degrees to release it.
3. Slide the old filter cartridge straight out of the housing and discard it.
4. Unpackage the new filter cartridge. Slide it into the filter housing as far as it will go with the grip end horizontal.
5. Push lightly inward on the filter while rotating it clockwise (to the right). The filter will then pull itself inward as it is rotated. Rotate the filter 90 degrees until it stops and the grip end is vertical. You may be able to feel a very light click as the filter locks into place.
6. Press a drinking glass against the water dispenser while checking for any leaks at the filter housing. Any spurts and sputters that occur as the system purges air out of the dispenser system are normal.
7. Continue dispensing water for 3-4 minutes or until 1.5 gallons of water has flowed through the system. You will likely need to empty and refill your glass several times.

8. Turn On the ice maker.
9. Press and hold the Water Filter reset button on the control panel for three seconds.
When the display changes from Red to Green, the status has been reset.

BEFORE YOU CALL



Concern	Potential Cause	Common Solution
Automatic Ice Maker		
Ice maker is not making any ice.	<ul style="list-style-type: none"> • Ice maker is turned off. • Refrigerator is not connected to water line or water valve is not open. • The water supply line is kinked. • The water filter is not seated properly. • The water filter may be clogged with foreign material. • Freezer ice maker wire signal arm is being held up by an item not allowing it to go in the on or down position. 	<ul style="list-style-type: none"> • Turn on ice maker. For the fresh food ice maker, press ice maker on-off button once. For the freezer ice maker, lower the arm to turn the ice maker on, or raise it and snap it in its upper position to turn the ice maker off. • Connect the unit to the household water supply and ensure the water valve is open. • Ensure that the supply line does not kink when the refrigerator is pushed into place against the wall. • Remove and re-install the water filter. Be sure to seat it fully into the locked position. • If water dispenses slowly or not at all, or if the filter is six months old or older, it should be replaced. • Move any item or frozen ice cubes that may block the signal arm from being in the on or down position. Additionally, the ice bin itself may be out of position so that it prevents the signal arm from dropping all the way down. Be sure the bin is pushed all the way to the rear of the shelf. See Automatic Ice Maker-Freezer section in manual.
Freezer ice maker will not stop making ice (select models).	<ul style="list-style-type: none"> • Ice maker wire signal arm is being held down by a package in the freezer that has fallen against ice maker. 	<ul style="list-style-type: none"> • Move any item or frozen ice cubes that may block the signal arm from being in the off or upward position. See Automatic Ice Maker-Freezer section in manual.



<p>Ice cubes are freezing together.</p>	<ul style="list-style-type: none"> • Ice cubes are not being used frequently enough or interruption of power for prolonged time. • Ice cubes are hollow (shells of ice with water inside). The hollow cubes break open in the bin and leak their water onto existing ice, which causes it to freeze together. 	<ul style="list-style-type: none"> • Remove ice container and discard ice. The ice maker will produce fresh supply. Ice should be used at least twice weekly to keep the cubes separated. • This generally occurs when the ice maker does not get enough water. This is usually the result of a clogged water filter or restricted water supply. Replace the water filter and if the condition still occurs check for a clogged Saddle Valve, water valve not turned on all the way or kinked water supply line.
<p>Dispenser will not dispense ice.</p>	<ul style="list-style-type: none"> • There is no ice in the bin to be dispensed. • The refrigerator doors are not completely closed. • Dispenser paddle has been pressed too long and the dispenser motor has overheated. 	<ul style="list-style-type: none"> • See the “Ice maker is not making any ice” section above. • Be sure the refrigerator doors are completely closed. • The motor overload protector will reset in about three minutes and then ice can be dispensed.
<p>Ice dispenser is jammed.</p>	<p>Ice has melted and frozen around auger due to infrequent use, temperature fluctuations, and/or power outages.</p> <ul style="list-style-type: none"> • Ice cubes are jammed between ice maker and back of ice container. 	<ul style="list-style-type: none"> • Remove ice container, thaw, and empty the contents. Clean container, wipe dry, and replace in proper position. When new ice is made, dispenser should operate. • Remove ice cubes that are jamming the dispenser.
<p>Dispenser will not dispense water.</p>	<p>Water filter not seated properly.</p> <ul style="list-style-type: none"> • Water filter is clogged. 	<ul style="list-style-type: none"> • Remove and reinstall the water filter. For Puresource Ultra II, be sure to rotate it to the right until it stops and the grip end is vertical.



	<ul style="list-style-type: none"> • Household water line valve is not open. 	<ul style="list-style-type: none"> • Replace filter cartridge. Be sure to rotate it to the right until it stops and the grip end is vertical. • Open household water line valve. See CONCERN column AUTOMATIC ICE MAKER.
Water not cold enough.	<ul style="list-style-type: none"> • The water dispensing system is not designed to chill water 	<ul style="list-style-type: none"> • Add ice to cup or container before dispensing water.
Water has an odd taste and/or odor.	<ul style="list-style-type: none"> • Water has not been dispensed for an extended period of time. • Unit not properly connected to cold water line. 	<ul style="list-style-type: none"> • Draw and discard 10-12 glasses of water to freshen the supply. • Connect unit to cold water line that supplies water to the kitchen faucet.
Door(s) will not close.	<ul style="list-style-type: none"> • Door was closed too hard, causing other door to open slightly. • Refrigerator is not level. It rocks on the floor when moved slightly. • Refrigerator is touching a wall or cabinet. 	<ul style="list-style-type: none"> • Close both doors gently. • Ensure floor is level and solid, and can adequately support the refrigerator. Contact a carpenter to correct a sagging or sloping floor. • Ensure floor is level and solid, and can adequately support the refrigerator. Contact a carpenter to correct a sagging or sloping floor.
Drawers are difficult to move.	<ul style="list-style-type: none"> • Food is touching shelf on top of drawer. • Track that drawers slide on is dirty 	<ul style="list-style-type: none"> • Remove top layer of items in drawer. • Ensure drawer is properly installed on track. • Clean drawer, rollers, and track. See Care & Cleaning.
Running of Refrigerator		
Compressor does not run.	<ul style="list-style-type: none"> • Freezer control is set to "OF". 	<ul style="list-style-type: none"> • Set freezer control.

	<ul style="list-style-type: none"> • Refrigerator is in defrost cycle. • Plug at electrical outlet is disconnected. • House fuse blown or tripped circuit breaker. • Power outage. 	<ul style="list-style-type: none"> • This is normal for a fully automatic defrost refrigerator. The defrost cycle occurs periodically, lasting about 30 minutes. • Ensure plug is tightly pushed into outlet. • Check/replace fuse with a 15 amp timedelay fuse. Reset circuit breaker. • Check house lights. Call local electric company.
Refrigerator seems to run too much or too long.	<ul style="list-style-type: none"> • Your variable speed compressor is designed to run 100% of the time except during the defrost cycle. At times it will run faster, such as after a defrost cycle. 	<ul style="list-style-type: none"> • It is normal for the compressor to run continuously except during defrost mode.
Digital Temperature Setting Display		
Digital temperature displays an error.	<ul style="list-style-type: none"> • Electronic control system has detected a performance problem. 	<ul style="list-style-type: none"> • Call your Electrolux service representative, who can interpret any messages or number codes flashing on the digital displays.
Water/Moisture/Frost Inside Refrigerator		
Moisture collects on inside of refrigerator walls.	<ul style="list-style-type: none"> • Weather is hot and humid. • Flipper mullion 	<ul style="list-style-type: none"> • The rate of frost buildup and internal sweating increases. • Adjust flipper mullion. (See “To adjust the flipper mullion” in the Installation section.)
Water collects on bottom side of drawer cover.	<ul style="list-style-type: none"> • Vegetables contain and give off moisture. 	<ul style="list-style-type: none"> • It is not unusual to have moisture on the bottom side of the cover. Move humidity control (some models) to lower setting.
		<ul style="list-style-type: none"> • Water collecting in bottom of drawer is normal. Dry items before putting

Water collects in bottom of drawer.	<ul style="list-style-type: none"> Washed vegetables and fruit drain while in the drawer. 	them in the drawer or store produce in tightly sealed bags to help reduce condensation inside of the drawer
Water/Moisture/Frost Outside Refrigerator		
Moisture collects on outside of refrigerator or between doors.	<ul style="list-style-type: none"> Weather is humid. 	<ul style="list-style-type: none"> This is normal in humid weather. When humidity is lower, the moisture should disappear.
Food in Fresh Food Compartment		
Food is freezing.	<ul style="list-style-type: none"> Temperature setting is too low. Temperature sensor is covered by food (right side of fresh food area). Food is covering the air ports. 	<ul style="list-style-type: none"> Move the setting to a higher degree. Allow space for air flow to the sensor. Allow space between the air ports and the food.

FEATURES AT A GLANCE

BASELINE MODEL

*Features may vary according to model

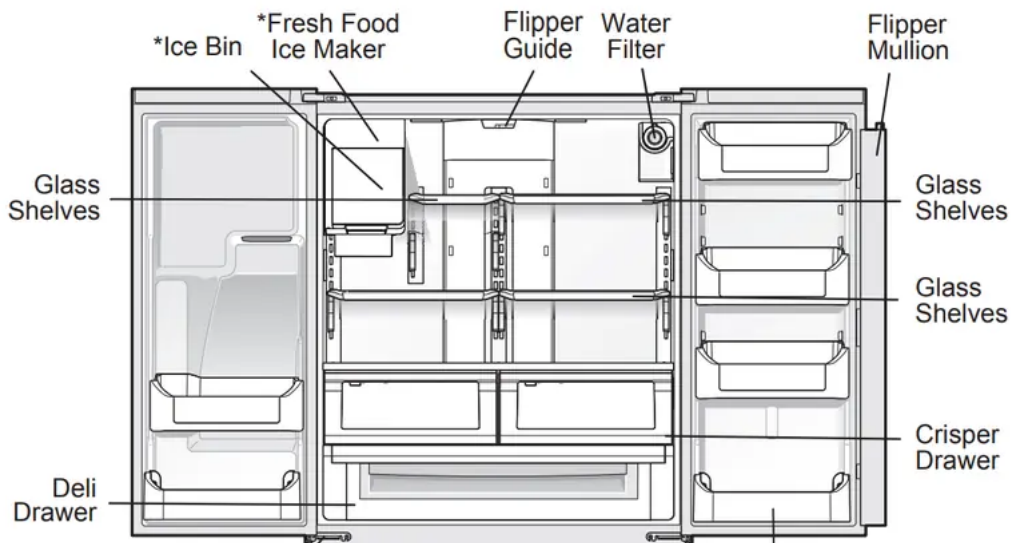

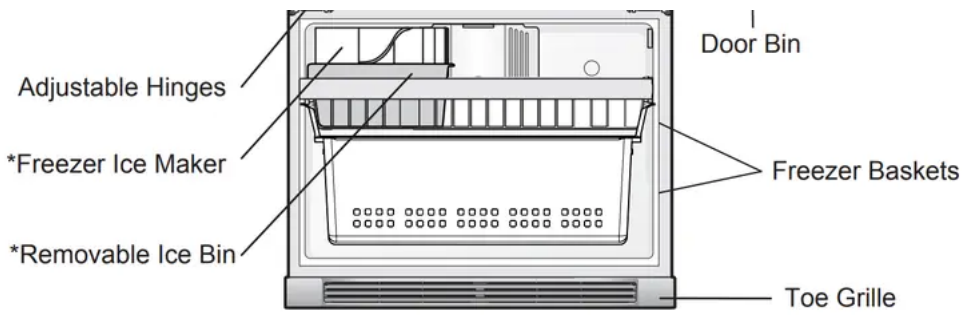

IMPORTANT

Features not purchased with your refrigerator can be purchased at www.frigidaire.com or by calling 1-800-944-9044.

GALLERY MODEL

***Features may vary according to model**

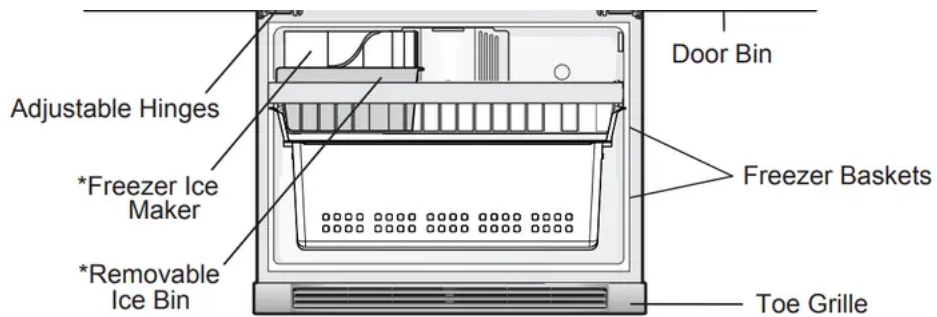
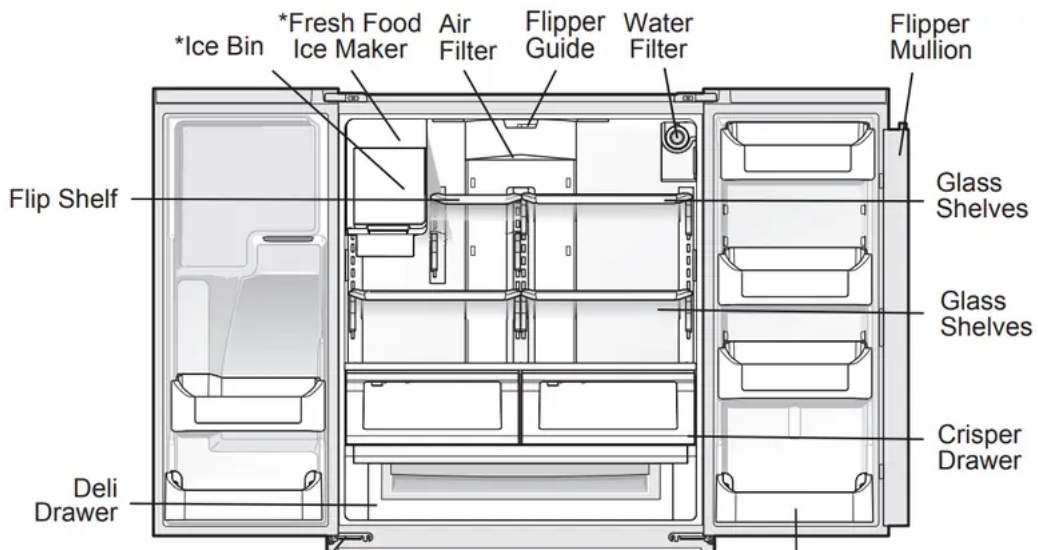



IMPORTANT

Features not purchased with your refrigerator can be purchased at www.frigidaire.com or by calling 1-800-944-9044.

PRO MODEL

***Features may vary according to model**

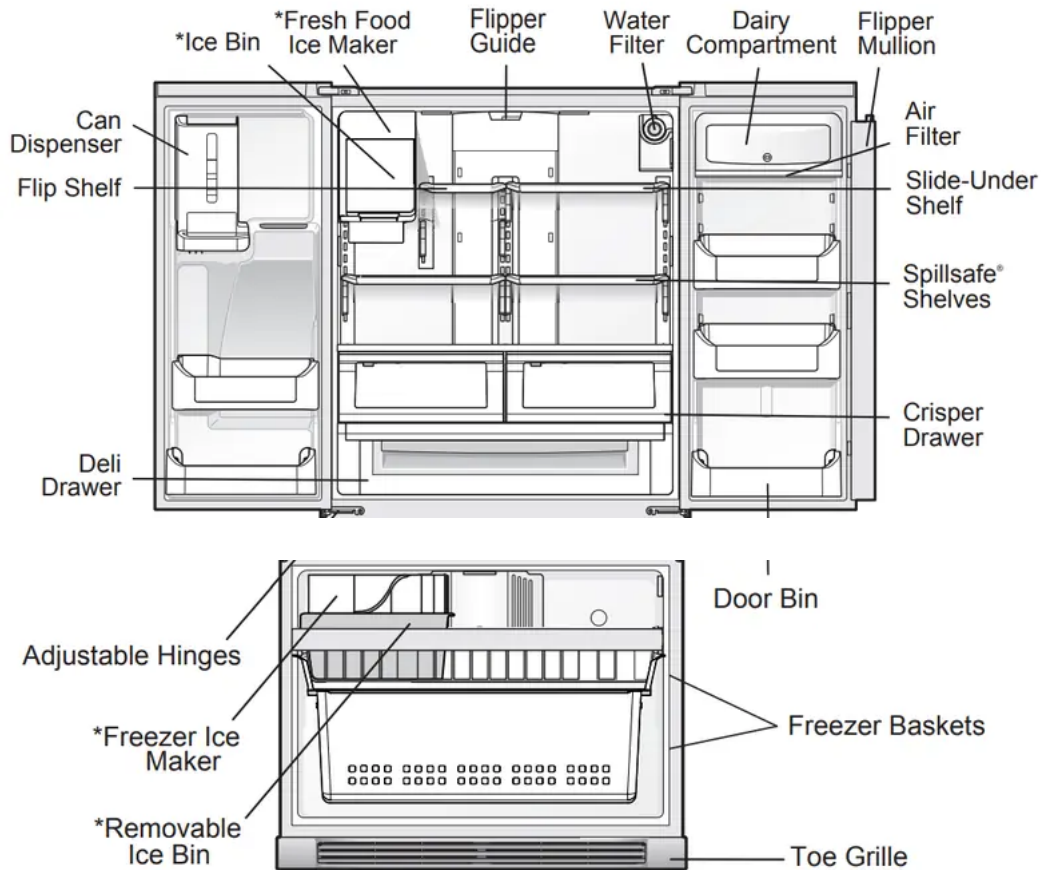

IMPORTANT

Features not purchased with your refrigerator can be purchased at www.frigidaire.com or by calling 1-800-944-9044.

CONTROLS

FRIGIDAIRE & FRIGIDAIRE GALLERY DISPENSER

User Interface (colors and options may vary by model)



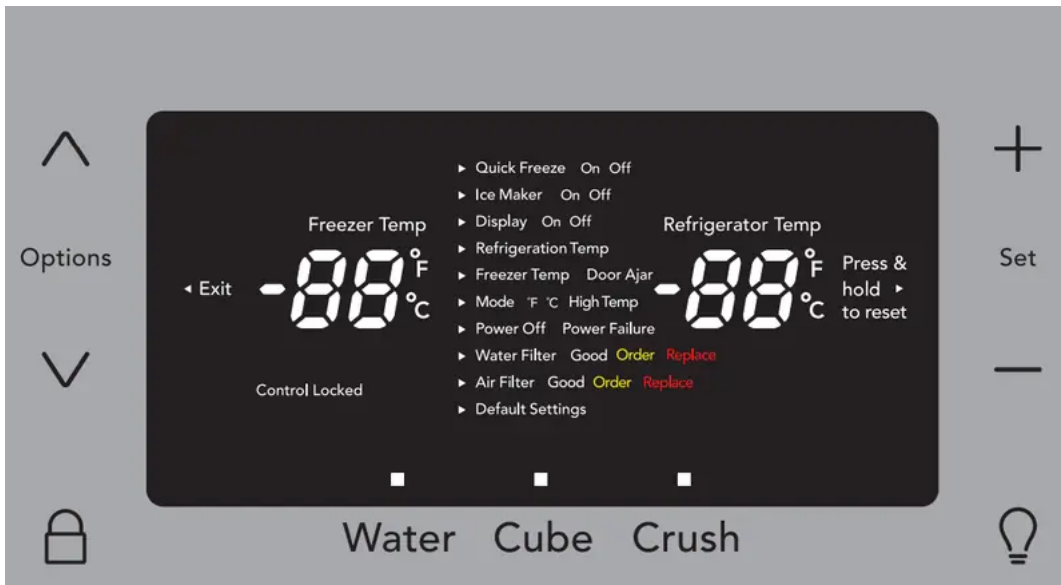

Enlarged view of above user interface display menu (colors and options may vary by model)

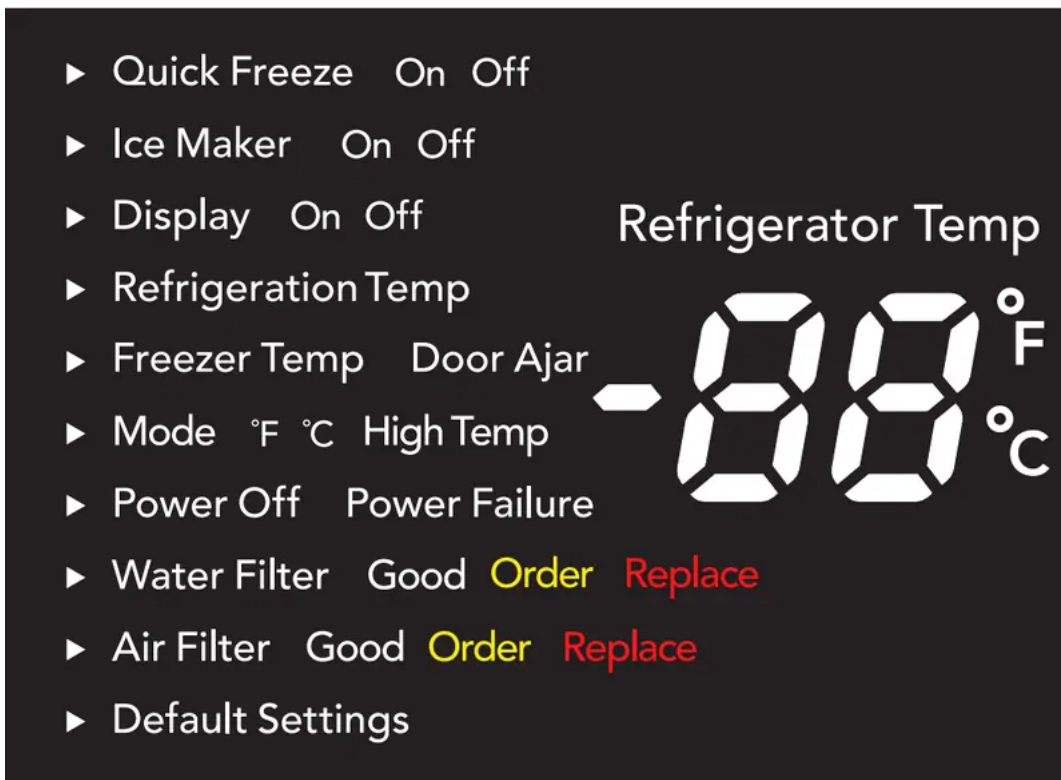

Options May Vary

Options (\wedge or \vee)	Used to enter and exit the options menu and make selections.
Exit	Toggles the options and run modes
Control Locked	While in the locked state, you will not be able to change any settings on the display nor dispense ice and water. The “Control Locked” indicator will flash and an audible warning tone is played.
Quick Freeze On Off	Activates a faster rate for freezing food and increases ice production in the freezer. Deactivates after 12 hours.
Ice Maker On Off	Toggles the ice maker in the refrigerator compartment “ON” or “OFF”. In the “Off” state, the indicator will blink when ice is dispensed.
Display On Off	Toggles the display of the temperature settings On and Off.
Refrigeration Temp	Allows the temperature setpoints to be adjusted. Control temperatures range from +33°F / +1°C to +47°F / +8°C.
Freezer Temp	Allows the temperature setpoints to be adjusted. Control temperatures range from -6°F / -21°C to +6°F / -15°C.
Mode °F °C	Toggles display from Fahrenheit to Celsius.
Light 	Toggles dispenser light On and Off
Power Off	Press and hold for three seconds to turn off the cooling system. It also turns off the ice maker and all dispenser functions. The display will read “power off”.
Water Filter	Displays the current status of the water filter (Good, Order, or Replace). To reset the filter status to “Good”, press and hold the “set” key for three seconds.
Air Filter	Displays the current status of the air filter (Good, Order, or Replace). To reset the filter status to “Good”, press and hold the “set” key for three seconds.
Default Settings	While in the default option, press and hold the “set” key for three seconds to reset all refrigerator settings to their factory default settings.

Set (+ or -)	Selects the current menu selection option.
Water	Press the “water” key to select water. An indicator light will be illuminated above the active feature.
Cube	Press the “cube” key to select cubed ice. An indicator light will be illuminated above the active feature.
Crush	Press the “crush” key to select crushed ice. An indicator light will be illuminated above the active feature.

Setting cooling temperatures (options may vary)



NOTE

The recommended settings for a product installed in a kitchen is 37°F for the fresh food compartment and 0°F for the freezer.



IMPORTANT

If your product has food freezing in the fresh food compartment, increase the temperature setting 1 or 2 degrees.

If you place food within 1 inch in front of the air ports, there may be the chance of freezing food.

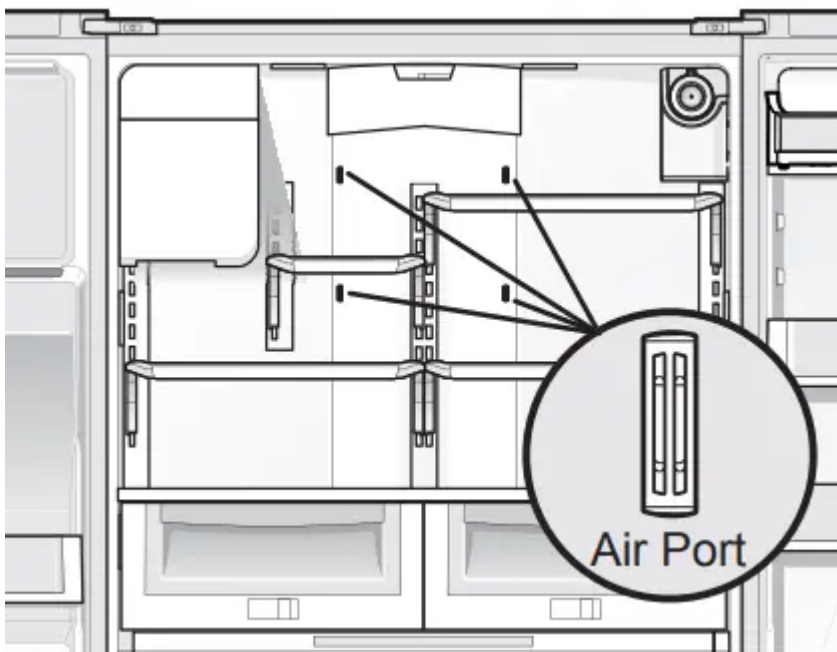



NOTE

Control features and alarms may vary by model.

Alarms

Power Failure

In the event of a power failure, the power fail alert will be illuminated. Press set to acknowledge the alarm. Other modes may be turned off until the alarm is acknowledged. While a power fail alert is displayed on the control panel, the unit will continue normal operation. The power fail alert on the control panel will be removed once in the user acknowledges the power fail condition by pressing any key on the control panel. The high temp alarm may also be illuminated until a safe operating range temperature has been reached.

Freezer Temp

If the freezer temperature reaches 26°F or greater, the alarm will sound and the temperature will flash. You can disable the alarm by pressing the set key but the “High Temp” indicator will illuminate until the temperature goes below 26°F.

Fresh Food Temp

If the fresh food temperature reaches 55°F or greater, the alarm will sound and the temperature will flash. You can disable the alarm by pressing the set key but the “High Temp” indicator will illuminate until the temperature goes below 55°F.

Door Ajar

If the freezer or fresh food doors have been left open for five minutes or more, an alarm will sound and the door ajar indicator will illuminate on the display. Press the set key to reset any system alarms.

Flapper

When “Cube” or “Crush” is selected, if the flapper (or ice chute door) is being held open by a jammed ice cube, an alarm will sound for two minutes. The alarm will reset after two minutes or when the ice cube is removed and the set key is pressed to reset.

Sabbath Mode

The Sabbath Mode is a feature that disables portions of the refrigerator and its controls in accordance with observance of the weekly Sabbath and religious holidays within the Orthodox Jewish community.

Sabbath Mode is turned ON and OFF by simultaneously pressing and holding both the “v” and “+” for five seconds. The display shows “Sb” while in Sabbath mode.

In the Sabbath Mode, the High Temp alarm is active for health reasons. For example, if the door is left ajar the High Temp alarm is activated. The refrigerator will function normally once the door is closed, without any violation of the Sabbath/Holidays. The High Temp alarm is permitted when cabinet temperature is outside the safe zone for 20 minutes. The alarm silences itself after 10 minutes while the High Temp icon stays lit until the Sabbath mode is exited.



NOTE

While in Sabbath Mode, neither the lights, dispenser, nor the control panel will work until Sabbath Mode is deactivated.

Refrigerator stays in Sabbath Mode after power failure recovery. It must be deactivated with the buttons on the control panel.

Although you have entered the Sabbath Mode, the ice maker will complete the cycle it had already initiated. The ice cube compartment will remain cold and new ice cubes can be made with standard trays.

NON-DISPENSER MODELS

User Interface In-Door Controls (options may vary)



IMPORTANT

Pressing the system on/off icon does not turn off power to your refrigerator. You must unplug the power cord from the wall outlet.

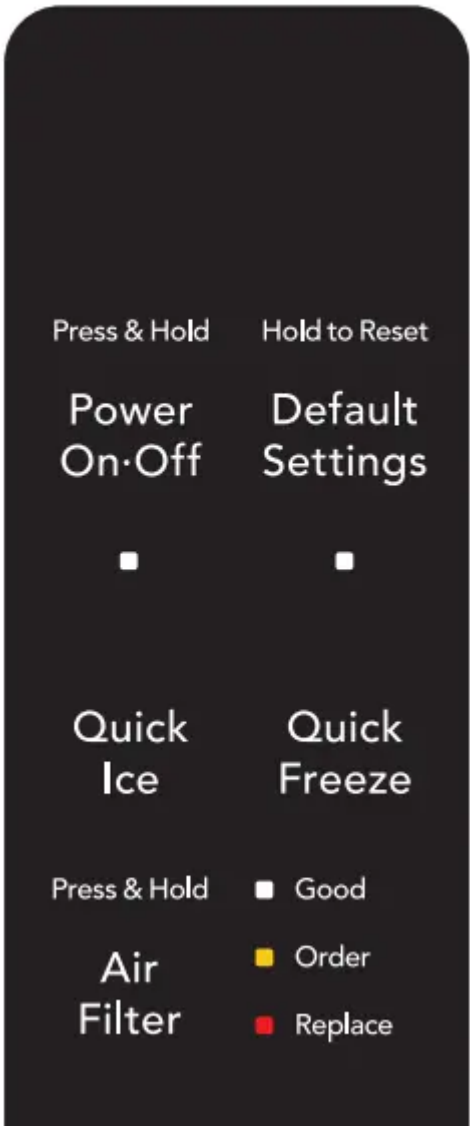



An indicator light will be illuminated above most active features.

Touch the icon to activate the options below.

Power On Off	Press and hold for three seconds to turn off the cooling system to clean the refrigerator. The digital displays will read OFF.
Default Settings	Resets all refrigerator settings such as temp, temp display and tones to their factory default settings.
Quick Freeze	Activates a faster rate for freezing food.
Quick Ice	Temporarily increases cooling for freezer to increase the production of ice
Air Filter	Filter condition status is always displayed when door is open. Press and hold for three seconds to reset after filter change.
Water Filter	Press and hold for three seconds to reset after filter change.
Alert Reset	Tones emitted by each key press can be turned off based on user preference. The sounds are muted when the red indicator is lit. Warning signals will stay active.
C/F	Touch to toggle display from Fahrenheit to Celsius.

Setting cooling temperatures

Press the + or – indicator to adjust the temperature to the desired setting.

The temperature setting will begin to blink with the first touch. The display will time out after 10 seconds and return to the basic display.



NOTE

The recommended settings for a product installed in a kitchen is 37°F for the fresh food compartment and 0°F for the freezer.

Alarms

Door Ajar	If the door has been left open for an extended period of time, an alarm will sound and the door ajar indicator will display on the bottom display of the control panel. The alarm is turned off by closing the door. The alert reset key will blink to prompt the reset of any active alarms. Press this key to reset any system alarms.
High Temp	In the event of a high temperature condition, the temperature display will blink and display "HI". After 20 minutes, the alarm will sound and the high temp indicator will be red on the bottom of the control panel. Upon acknowledging the alarm, the highest temperature reached will be displayed and the refrigerator will resume normal operation. In case the high temp alarm is not acknowledged at the first alarm sound time out, when the door is first opened, the alarm sound will be repeated.
Power Fail	Fail In the event of a power failure, the power fail alert will be displayed and the temperature display will blink until the alert reset icon is pressed, acknowledging the alarm. Other modes may be turned off until the alarm is acknowledged. The power fail alert is turned off and the refrigerator will resume normal operation. The high temp alarm may also be illuminated until a safe operating range temperature has been reached.

"Sabbath Mode"

The Sabbath Mode is a feature that disables portions of the refrigerator and its controls for, in accordance with observance of the weekly Sabbath and religious holidays within the Orthodox Jewish community.

Sabbath Mode is turned ON and OFF by simultaneously pressing and holding the freezer temp "-" and the refrigerator temp "+" indicators for five seconds. The display shows "Sb" while in Sabbath mode.

In the Sabbath Mode, the High Temp alarm is active for health reasons. For example, if the door is left ajar the High Temp alarm is activated. The refrigerator will function normally once the door is closed, without any violation of the Sabbath/Holidays. The High Temp alarm is permitted when cabinet temperature is outside the safe zone for 20 minutes. The alarm silences itself after 10 minutes while the High Temp icon stays lit until the Sabbath mode is exited.

NOTE

While in Sabbath Mode, neither the lights nor the control panel will work until Sabbath Mode is deactivated.

Refrigerator stays in Sabbath Mode after power failure recovery. It must be deactivated with the buttons on the control panel.



During Sabbath Mode, the freezer ice maker will continue to work and must be manually turned off to be compliant with the Sabbath observances.

User Interface In-Door Controls (options may vary)



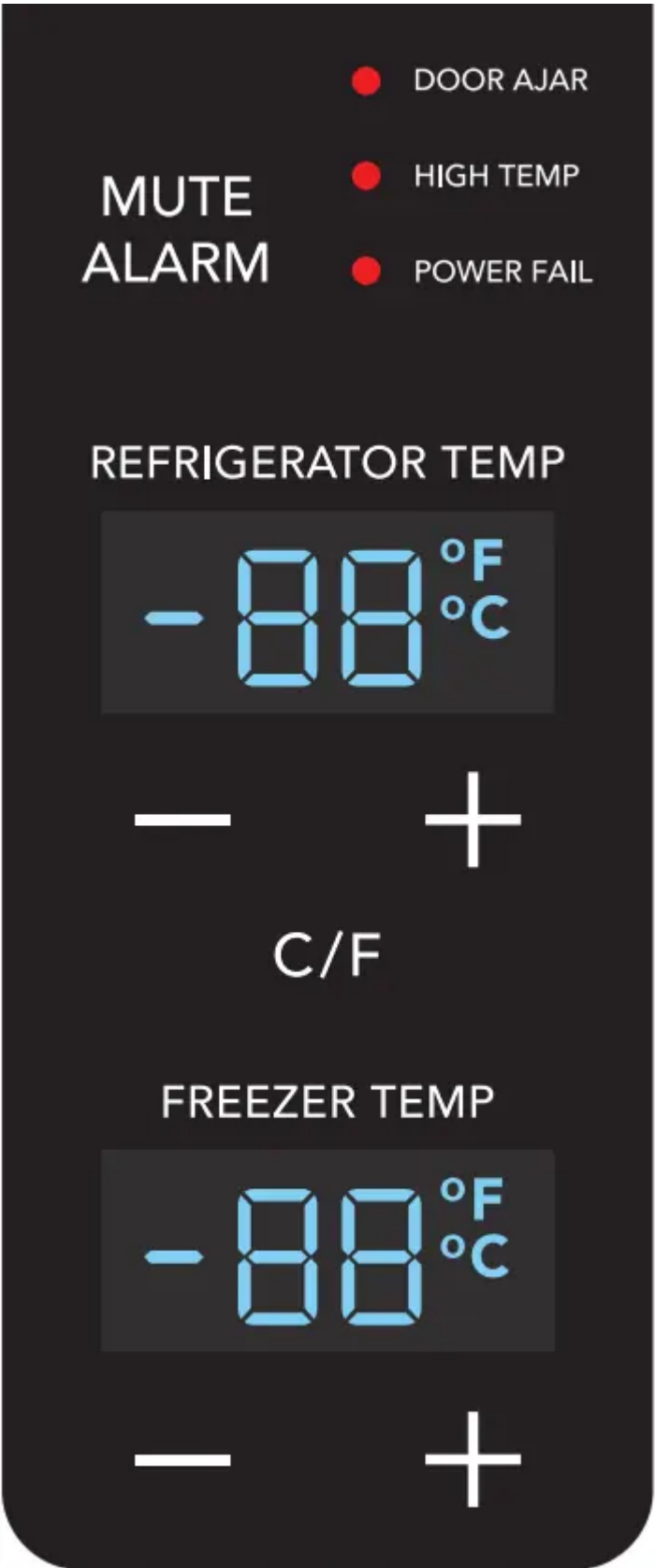



POWER ON-OFF	Press and hold for three seconds to turn off the cooling system. It also turns off the ice maker and all dispenser functions. The display will read "OFF".
DEFAULT SETTINGS	Press and hold for three seconds to reset all refrigerator settings to their factory default settings.
ICE MAKER ON-OFF	The Ice Maker is on if the LED above the Icon is illuminated. Ice dispensing will still function. Press and hold the button for 3 seconds to toggle the Ice Maker on and off.
POWERPLUS FREEZE	Activates a faster rate for freezing food and increases ice production in the freezer. Deactivates after 12 hours.
AIR FILTER	Displays the current status of the air filter (GOOD, ORDER, or REPLACE). To reset the filter status to "GOOD", press and hold for three seconds.
WATER FILTER	Displays the current status of the water filter (GOOD, ORDER, or REPLACE). To reset the filter status to "GOOD", press and hold for three seconds.
MUTE ALARM	Tones emitted by each key press can be turned off based on user preference. The sounds are muted when the red indicator is lit. Warning signals will stay active.
REFRIGERATOR TEMP	Allows the temperature setpoints to be adjusted. Press the "-" or "+" indicator to adjust the temperature to the desired setting. Control temperatures range from +33°F / +1°C to +47°F / +8°C.
FREEZER TEMP	Allows the temperature setpoints to be adjusted. Press the "-" or "+" indicator to adjust the temperature to the desired setting. Control temperatures range from -6°F / -21°C to +6°F / -15°C.
C/F	Toggles display between Celsius and Fahrenheit.

Dispenser Controls (options may vary)

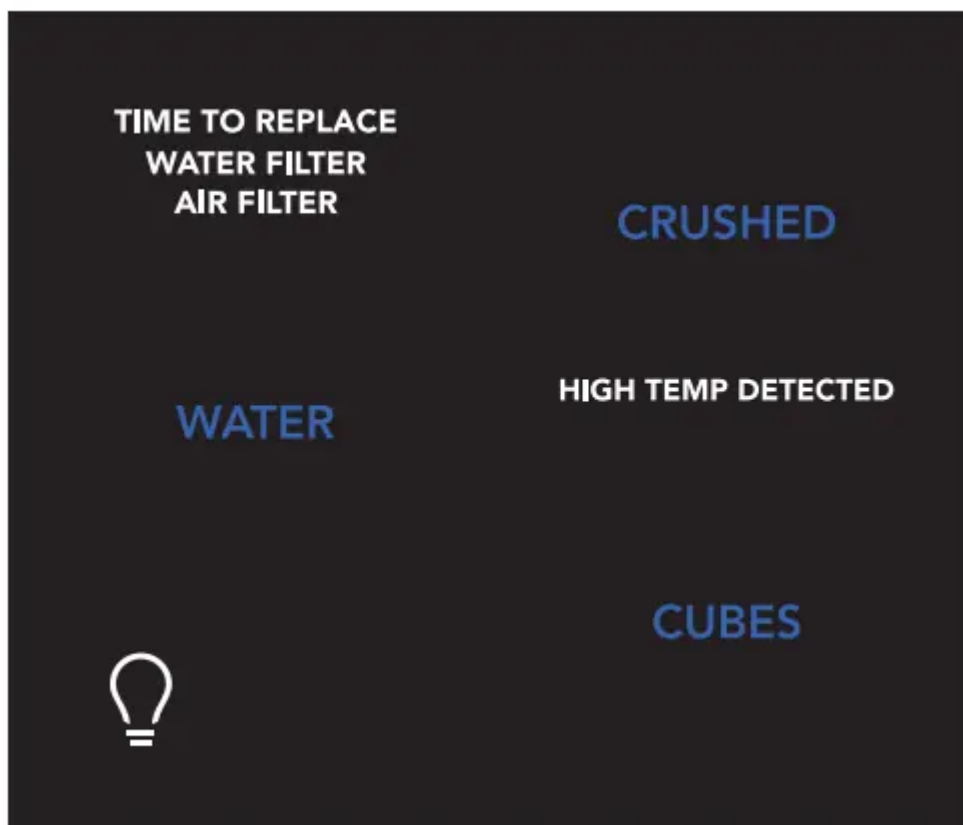



WATER	Press the “WATER” key to select water.
CUBES	Press the “CUBES” key to select cubed ice.
CRUSHED	Press the “CRUSHED” key to select crushed ice.
 light	Toggles dispenser light on and off

Alarms

Power Failure

In the event of a power failure, the power fail alert will be illuminated. Press “mute alarm” to acknowledge the alarm. Other modes may be turned off until the alarm is acknowledged. While a power failure alert is displayed on the control panel, the unit will continue normal operation. The power fail alert on the control panel will be removed once the user acknowledges the power fail condition by pressing any key on the control panel. The high temp alarm may also be illuminated until a safe operating range temperature has been reached.

Freezer Temp

If the freezer temperature reaches 26°F or greater, the alarm will sound and the temperature will flash and the dispenser control will display “HIGH TEMP DETECTED”. You can disable the alarm by pressing “mute alarm” but the “HIGH TEMP DETECTED” indicator will illuminate until the temperature goes below 26°F.

Fresh Food Temp

If the fresh food temperature reaches 55°F or greater, the alarm will sound and the temperature will flash and the dispenser control will display “HIGH TEMP DETECTED”. You can disable the alarm by pressing “mute alarm” but the “HIGH TEMP DETECTED” indicator will illuminate until the temperature goes below 55°F.

Door Ajar

If the freezer or fresh food doors have been left open for five minutes or more, an alarm will sound and the door ajar indicator will illuminate on the display. Press “mute alarm” to reset any system alarms.

Flapper

When “CUBES” or “CRUSHED” is selected, if the flapper (or ice chute door) is being held open by a jammed ice cube, an alarm will sound for two minutes and the current selection will blink on the dispenser control. The alarm will reset after two minutes or when the ice cube is removed.

Sabbath Mode

The Sabbath Mode is a feature that disables portions of the refrigerator and its controls in accordance with observance of the weekly Sabbath and religious holidays within the Orthodox Jewish community

Sabbath Mode is turned ON and OFF by simultaneously pressing and holding both the freezer “-” and the refrigerator “+” for five seconds. The display shows “Sb” while in Sabbath mode.

In the Sabbath Mode, the High Temp alarm is active for health reasons. For example, if the door is left ajar the High Temp alarm is activated. The refrigerator will function normally once the door is closed, without any violation of the Sabbath/Holidays. The High Temp alarm is permitted when cabinet temperature is outside the safe zone for 20 minutes. The alarm silences itself after 10 minutes while the High Temp icon stays lit until the Sabbath mode is exited.

NOTE

While in Sabbath Mode, neither the lights, dispenser, nor the control panel will work until Sabbath Mode is deactivated.

Refrigerator stays in Sabbath Mode after power failure recovery. It must be deactivated with the buttons on the control panel.

Although you have entered the Sabbath Mode, the ice maker will complete the cycle it had already initiated. The ice cube compartment will remain cold and new ice cubes can be made with standard trays.

During Sabbath Mode, the freezer ice maker will continue to work and must be manually turned off to be compliant with the Sabbath observances.

CARE & CLEANING

Protecting your investment

Keeping your refrigerator clean maintains its appearance and prevents odor build-up. Wipe up any spills immediately and clean the freezer and fresh food compartments at least twice a year

NOTE

Do not use abrasive cleaners such as window sprays, scouring cleansers, flammable fluids, cleaning waxes, concentrated detergents, bleaches, or cleansers containing petroleum products on plastic parts, interior doors, gaskets, or cabinet liners. Do not use paper towels, scouring pads, or other abrasive cleaning materials.

- Never use metallic scouring pads, brushes, abrasive cleaners, or strong alkaline solutions on any surface.
- Never use CHLORIDE or cleaners with bleach to clean stainless steel.
- Do not wash any removable parts in a dishwasher.
- Always unplug the electrical power cord from the wall outlet before cleaning.

If you set your temperature controls to turn off cooling, power to lights and other electrical components will continue until you unplug the power cord from the wall outlet.

- Remove adhesive labels by hand. Do not use razor blades or other sharp instruments which can scratch the appliance surface.
- Do not remove the serial plate. Removal of your serial plate voids your warranty.
- Before moving your refrigerator, raise the anti-tip brackets so the rollers will work correctly. This will prevent the floor from being damaged.

Refer to the guide on the next page for details on caring and cleaning specific areas of your refrigerator.

CAUTION

- Pull the refrigerator straight out to move it. Shifting it from side to side may damage flooring. Be careful not to move the refrigerator beyond the plumbing connections.
- Damp objects stick to cold metal surfaces. Do not touch refrigerated surfaces with wet or damp hands.

IMPORTANT

If you store or move your refrigerator in freezing temperatures, be sure to completely drain the water supply system. Failure to do so could result in water leaks when the refrigerator is put back into service. Contact a service representative to perform this operation.

Vacation and moving tips

Occasion Tips	
Short Vacations	<ul style="list-style-type: none"> • Leave refrigerator operating during vacations of three weeks or less. • Use all perishable items from refrigerator compartment. • Turn automatic ice maker off and empty ice bucket, even if you will only be gone a few days.
Long Vacations	<ul style="list-style-type: none"> • Remove all food and ice if you will be gone one month or more. • Turn the cooling system off (see “Controls” section for location of On/Off button) and disconnect power cord. • Turn water supply valve to closed position. • Clean interior thoroughly. • Leave both doors open to prevent odors and mold build-up. Block doors open if necessary.
Moving	<ul style="list-style-type: none"> • Remove all food and ice. • If using a handcart, load from the side. • Adjust rollers all the way up to protect them during sliding or moving. • Pad cabinet to avoid scratching surface.



Care & Cleaning Tips		
Part	What To Use	Tips and Precautions
Interior & Door Liners	<ul style="list-style-type: none"> • Soap and water • Baking soda and water 	Use two tablespoons of baking soda in one quart of warm water. Be sure to wring excess water out of sponge or cloth before cleaning around controls, light bulb or any electrical part.
Door Gaskets	<ul style="list-style-type: none"> • Soap and water 	Wipe gaskets with a clean soft cloth.
Drawers & Bins	<ul style="list-style-type: none"> • Soap and water 	Use a soft cloth to clean drawer runners and tracks.
Glass Shelves	<ul style="list-style-type: none"> • Soap and water • Glass cleaner • Mild liquid sprays 	Allow glass to warm to room temperature before immersing in warm water.
Toe Grille	<ul style="list-style-type: none"> • Soap and water • Mild liquid sprays • Vacuum attachment 	Vacuum dust from front of toe grille. Remove toe grille (see Installation Instructions). Vacuum backside, wipe with sudsy cloth or sponge. Rinse and dry.
Exterior & Handles	<ul style="list-style-type: none"> • Soap and water • Non Abrasive Glass Cleaner 	Do not use commercial household cleaners containing ammonia, bleach or alcohol to clean handles. Use a soft cloth to clean smooth handles. DO NOT use a dry cloth to clean smooth doors.
Exterior & Handles	<ul style="list-style-type: none"> • Soap and water 	Never use CHLORIDE or cleaners with bleach to clean stainless steel.



(Stainless Steel Models Only)	<ul style="list-style-type: none"> • Stainless Steel Cleaners 	<p>Clean stainless steel front and handles with non-abrasive soapy water and a dishcloth. Rinse with clean water and a soft cloth. Use a non-abrasive stainless steel cleaner. These cleaners can be purchased at most home improvement or major department stores. Always follow manufacturer's instructions. Do not use household cleaners containing ammonia or bleach.</p> <p>NOTE: Always clean, wipe and dry with the grain to prevent scratching. Wash the rest of the cabinet with warm water and mild liquid detergent. Rinse well, and wipe dry with a clean soft cloth.</p>

Warning

This content is compiled from multiple sources and is provided for reference purposes only. It may not be complete or fully applicable to all situations. If you are unable to resolve your issue, please contact the product manufacturer or an authorized service provider for official support.

