

Unit Specifications and Features

Product overview

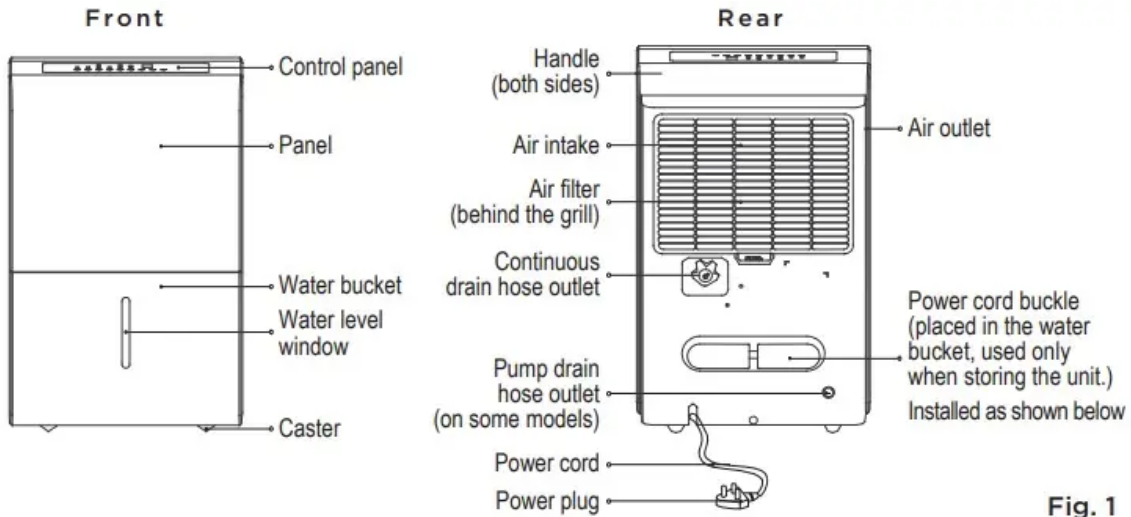
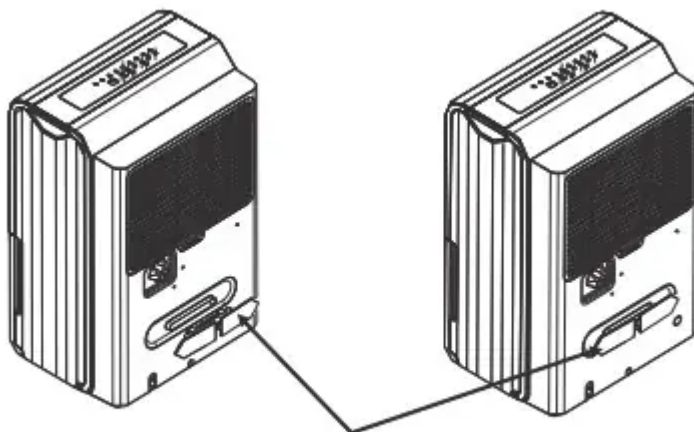

Fig. 1



Insert the power cord buckle into the unit.

Fig. 2

NOTE: All the pictures in this manual are for illustrative purposes only. The actual shape of the air conditioner you purchased may be slightly different, but its operations and functions are similar.

Accessories

Pump drain hose (1 pc) (only for the unit with pump feature)



Power cord buckle (1 pc)

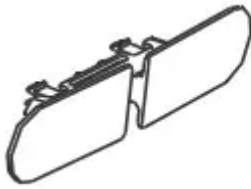

Specifications

MODEL			MDP30SR71	MDP50SR71	MDP70SR71	MDP70PR71 (w/ pump)	
Power supply		Ph-V-Hz	1Ph, 115V-, 60Hz	1Ph-115V-60Hz	1Ph-115V-60Hz	1Ph-115V-60Hz	
Performance	Moisture removal	Pints/day	30	50	70	70	
	Rated input	W	295	495	690	690	
	Rated current	A	2.8	4.7	6.5	6.5	
	Energy factor	L/kWh	2.0	2.0	2.0	2.0	
Starting current		A	14	24	29	29	
System	Refrigerant type	ozs	R-410A	R-410A	R-410A	R-410A	
	Design pressure	PSIG	540/300	540/300	540/300	540/300	
	Water tank volume	L	3	6	6	6	
	Air flow (Hi/Med/Lo)	m ³ /h		234/219	320/280	320/280	320/280
		CFM (ft ³ /min)		138/129	188/165	188/165	188/165
Noise level (Hi/Med/Lo)	dB(A)		54.3	48	53.5	53.5	
Control type			Digital Display	Digital Display	Digital Display	Digital Display	
Application	Set RH Range		35%-85%RH	35%-85%RH	35%-85%RH	35%-85%RH	
	Ambient temperature	°C	5 - 35	5 - 35	5 - 35	5 - 35	
		°F	41 - 95	41 - 95	41 - 95	41 - 95	
Dimension (W*D*H)		mm	409x272x493	423x297x620	423x297x620	423x297x620	
		in	16.1x10.7x19.4	16.8x11.7x24.4	16.8x11.7x24.4	16.8x11.7x24.4	
Net/Gross weight		kg	13.9/15.2	18/19.3	19.9/21.2	20.9/22.2	
		lb	30.6/33.5	40/43	43.9/46.7	46.1/48.9	

Operating Instructions

Key Pad Features

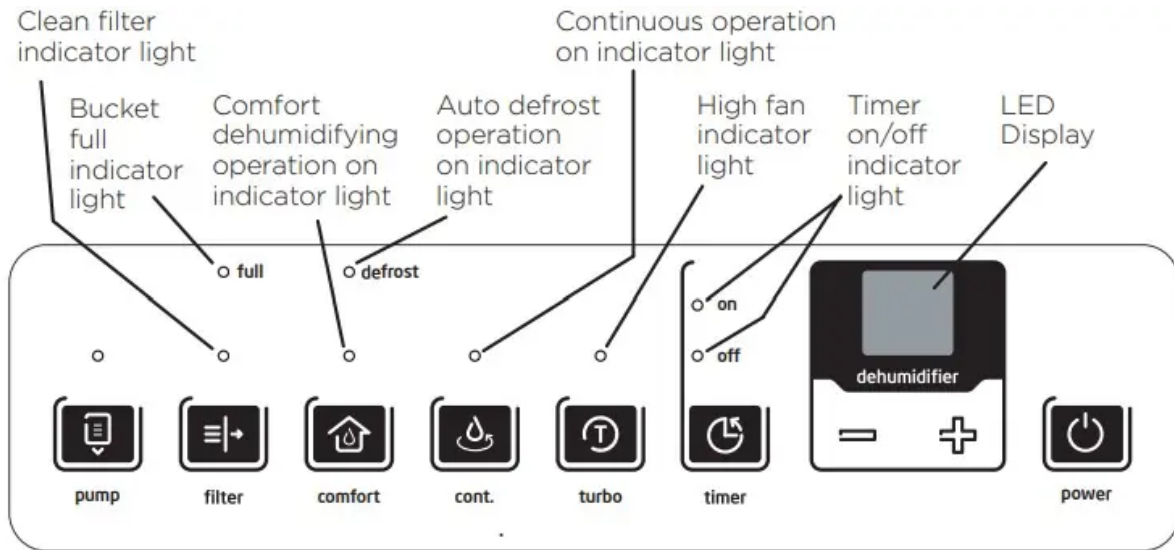

Control Pads

When you push the button to change operation modes, the unit will make a beep sound to indicate that it is changing modes.

(COMFORT) Button

- Press to activate the comfort dehumidifying operation.

(FILTER) Button

- This feature is a reminder to clean the Air Filter for more efficient operation. The LED (light) will illuminate after 250 hours of operation. To reset after cleaning the filter, press the Filter button and the light will go off.

(CONTINUE) Button

- Press to activate the continuous dehumidifying operation

(TURBO) Button

- Control the Turbo speed. Press to select either Turbo or normal fan speed. Set the Turbo control to high for maximum moisture removal. When room humidity is at your preferred level, it is advised to turn off Turbo speed.

(TIMER) Button

- Starts the Timer ON and Timer OFF function setting.

Up/Down Buttons (+ / -)

Humidity Set Control Buttons

- The humidity level can be set within a range of 35% RH (Relative Humidity) to 85% RH (Relative Humidity) in 5% increments.
- For drier air, press the - button and set to a lower value (%).
- For damper air, press the + button and set a higher value (%).

TIMER Set Control Buttons

- Use the - and key + buttons to set the Timer ON or Timer OFF from 0 to 24 hours.

(POWER) Button

- Press to turn the dehumidifier on and off.

LED Display

- Shows the set % humidity level from 35% to 85% or auto start/stop time (0 ~ 24) while setting, then shows the actual (+/- 5% accuracy) room % humidity level in a range of 30% RH (Relative Humidity) to 90% RH (Relative Humidity)

Error Codes and Protection Code:

- AS - Humidity sensor error - Unplug the unit and plug it back in. If error persists, contact Customer Service.
- ES - Tube Temperature sensor of the evaporator error - Unplug the unit and plug it back in. If error persists, contact Customer Service.
- P2 - Bucket is full or bucket is not in right position - Empty the bucket and replace it in the right position. (only available for the unit with no pump feature.)
- P2 - Bucket is full - Empty the bucket. (only available for the unit with pump feature.)
- EC - Refrigerant leakage detection - Display area will show EC when the unit detects refrigerant leakage. If error persists, contact Customer Service
- E3 - Unit malfunction - Unplug the unit and plug it back in. If error persists, contact Customer Service.
- Eb - Bucket is removed or not in right position - Replace the bucket in the right position. (only available for the unit with pump feature.)

Other Features

Bucket Full Light

- Lights up when the bucket is ready to be emptied.

Auto Shut Off

- The dehumidifier shuts off when the bucket is full, or when the bucket is removed or not replaced in the proper position. When the setting humidity is reached, the unit will be shut off automatically. The fan motor will continue operating.

Auto Defrost

- When frost builds up on the evaporator coils, the compressor will cycle off and Auto Defrost function will run automatically

Wait 3 minutes before resuming operation

- After the unit has stopped, it can not be restarted in the first 3 minutes to protect compressor operation. The unit will restart automatically after 3 minutes.

Auto-Restart

- If the unit stops unexpectedly due to a power cut, it will restart with the previous function setting automatically when the power resumes.

Setting the Timer ON and Timer OFF

- When the unit is on, first press the Timer button, the Timer OFF indicator light illuminates. It indicates the Timer OFF program is initiated. Press it again the Timer ON indicator light illuminates. It indicates the Timer ON is initiated.
- When the unit is off, first press the Timer button, the Timer ON indicator light illuminates. It indicates the Timer ON program is initiated. Press it again the Timer OFF indicator light illuminates. It indicates the Timer OFF is initiated.
- Press or hold the - and + key buttons to change the Timer by 0.5 hour increments, up to 10 hours, then at 1 hour increments up to 24 hours. The control will count down the time remaining until start.
- The selected time will register in 5 seconds and the system will automatically revert back to display the previous humidity setting.
- When the Timer ON and Timer OFF times are set, within the same program sequence, indicator lights illuminate identifying both ON and OFF times are now programmed.
- Turning the unit ON or OFF at any time or adjusting the timer setting to 0.0 will cancel the Timer function.
- When LED display window displays the code of P2, the Auto Start/Stop function will also be cancelled.

Removing Collected Water

There are three ways to remove collected water:

1. Use the bucket

- When the unit is off, if the bucket is full, the Full indicator light will light.
- When the unit is on, if the bucket is full, the compressor and the fan turn off, and the Full indicator light will light, the digital display shows P2.
- Slowly pull out the bucket. Grip the left and right handles securely, and carefully pull out straight so water does not spill. Do not put the bucket on the as because the bottom of the bucket is uneven. Otherwise water may be spilled.
- Throw away the water and reposition the bucket.
- The unit will restart operation when the bucket back in place.

1. Pull out the bucket.



2. Hold both sides of the bucket evenly, and pull it out from the unit.

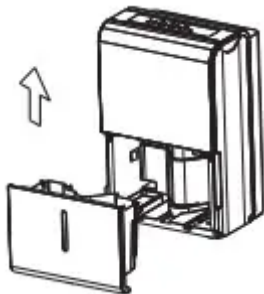

3. Pour the water out.

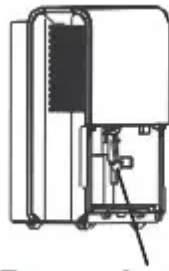

Pump hose drops

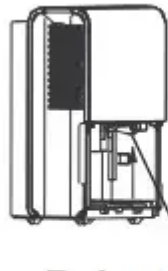

**Reinstall pump
hose properly**

2. Continuous draining

- Water can be automatically emptied into a floor drain by attaching the unit with a water hose (1d Ø 5/16", not included) with a female threaded end
- Remove the plastic cover from the back drain outlet of the unit and set aside, then insert the drain hose through the drain outlet of the unit and lead the drain hose to the floor drain or a suitable drainage facility. (See Fig. 9 and Fig. 10)
- When you remove the plastic cover, if there is some water in the back drain outlet of the unit you must dry it. Make sure the hose is secure so there are no leaks and the end of the hose is level or down to let the water flow.
- Direct the hose toward the drain, making sure that there are no kinks that will stop the water flowing.
- Select the desired humidity setting and fan speed on the unit for continuous draining to start.

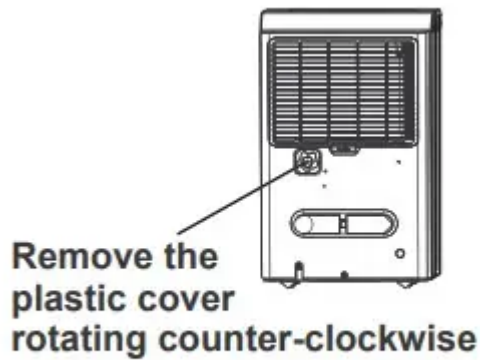

Fig. 9

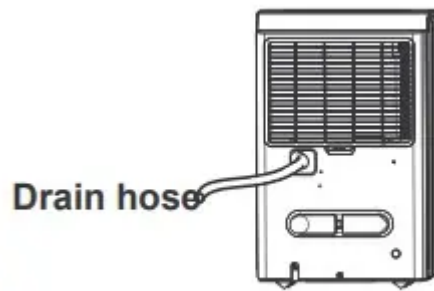

Fig. 10

3. Pump draining (Pump models only)

Water can be automatically emptied into a floor drain or a suitable drainage facility by attaching the pump drain out with a pump drain hose (\varnothing od = 1/4", supplied).

- Remove the continuous drain hose from the unit and install the plastic cover to the continuous drain hose outlet of the unit by clockwise rotation. (See Fig. 11)
- Insert the pump drain hose into the pump drain hose outlet for at least 15mm (See Fig. 11), then lead the water hose to the floor drain or a suitable drainage facility.
- Press the pump pad on the unit to activate the pump operation. When the bucket is full the pump starts to work.

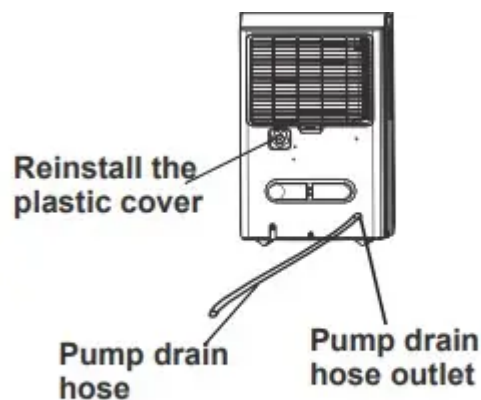

Fig. 11

Installation Instructions

Positioning the Unit

A dehumidifier operating in a basement will have little or no effect in drying an adjacent enclosed storage area, such as a closet, unless there is adequate circulation of air in and out of the area. (See Fig. 13)

- Do not use outdoors.

- This dehumidifier is intended for indoor residential applications only. This dehumidifier should not be used for commercial or industrial applications.
- Place the dehumidifier on a smooth, level floor strong enough to support the unit with a full bucket of water.
- Allow at least 8 inches of air space on all sides of the unit for air circulation (at least 16 inches for air outlet).
- Place the unit in an area where the temperature will not fall below 41°F (5°C). The coils can become covered with frost at at lower temperatures, which may reduce performance.
- Place the unit away from any clothes dryer, heater or radiator.
- Close all doors, windows and other outside openings to the room.

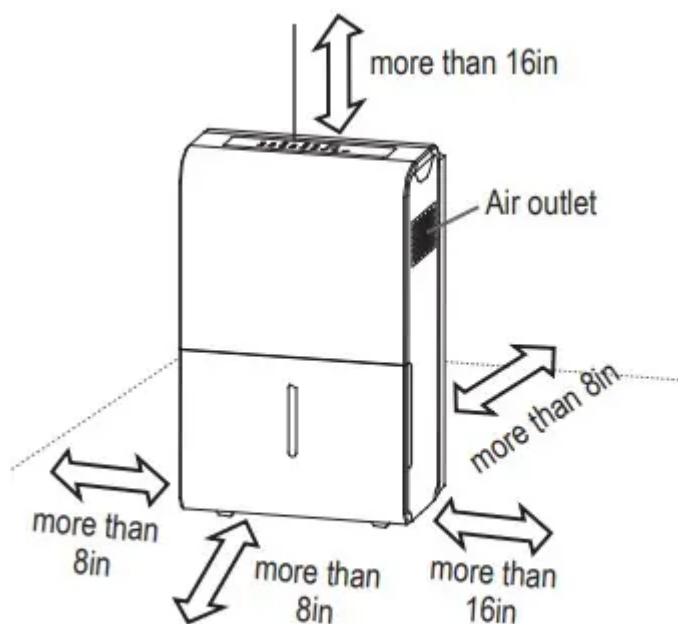

Fig. 13

Care and Cleaning

1. Clean the Grill and Case

- Use water and a mild detergent. Do not use bleach or abrasives.
- Do not splash water directly onto the unit. Doing so may cause an electrical shock, cause the insulation to deteriorate, or cause the unit to rust.
- The air intake and outlet may get dirty during operation, use a vacuum cleaner or brush to clean.

2. Clean the bucket

- Every few weeks, clean the bucket thoroughly to prevent growth of mold, mildew and bacteria. Partially fill the bucket with clean water and mild detergent. Swish it around in the bucket, empty and rinse.

3. Clean the air filter

- To remove the filter, pull filter outwards (See Fig. 14).
- Wash the filter with clean water then dry.
- Re-install the filter, replace bucket.

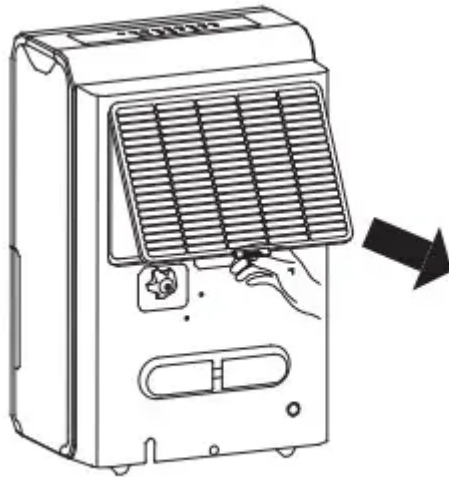

Fig. 14

Troubleshooting Tips

Before calling for service, review this list. It may save you time and money. This list includes common occurrences that are not the result of defective workmanship or materials in this appliance.

Unit does not start

- Make sure the dehumidifier's plug is connected firmly into the wall outlet.
- Check the house fuse/circuit breaker box.
- Dehumidifier has reached its preset level or bucket is full.
- Water bucket is not in the proper position.

Dehumidifier does not dry the air as it should

- Not enough time to remove the moisture.
- Make sure there are no curtains, blinds or furniture blocking the front or back of the dehumidifier.
- The humidity control may not be set low enough.

- Check that all doors, windows and other openings are securely closed.
- Room temperature is too low, below 5°C(41°F).
- There is a water vapor source in the room.

The unit makes a loud noise when operating

- Air filter may be dirty. Clean filter. Refer to Care and Cleaning section.
- The unit is tilted instead of upright as it should be.
- The floor surface is not level.

Frost appears on the coils

- This is normal. The dehumidifier has Auto defrost feature.

Water on floor

- Hose to connector or hose connection may be loose.
- Intend to use the bucket to collect water, but the back drain plug is removed.

ES, AS, P2, EC, Eb and E3 appear in the display

- These are error codes and protection code. Check Operating Instructions.

The pump operation on light blinks at 1 Hz

- Clean the pump filter.
- Check the pump hose is not blocked or leaking.
- Empty the water bucket.

Warning

This content is compiled from multiple sources and is provided for reference purposes only. It may not be complete or fully applicable to all situations. If you are unable to resolve your issue, please contact the product manufacturer or an authorized service provider for official support.