

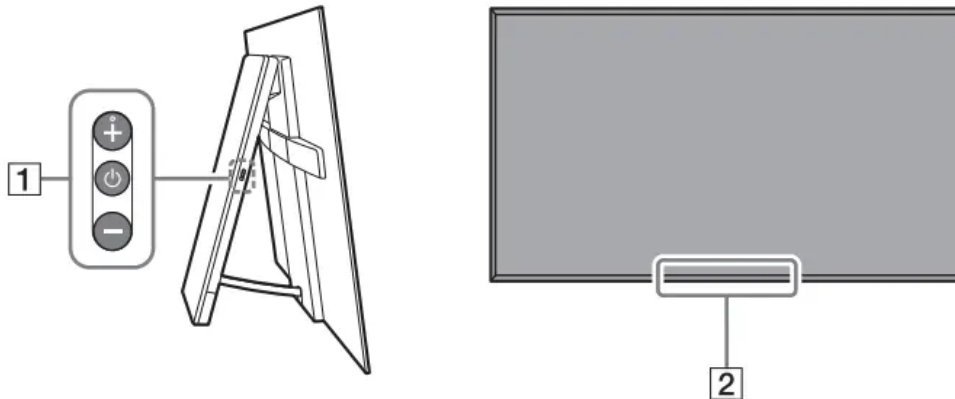



## Parts and Controls

### Controls and Indicators



1.  (Power) / + / -

When the TV is off, Press  to power on.

When the TV is on, Press and hold  to power off. Press  repeatedly to change the function, then press + or - button to:

- Adjust the volume.
- Select the channel.
- Select the input source of TV.

2. Remote Control sensor\* / Light sensor\* / Illumination LED: The illumination LED lights up or blinks according to the status of the TV. For more information, refer to the Help Guide.

\* Do not place anything near the sensor.

## Using Remote Control

### Remote Control Parts Description

The remote control shape, location, availability and function of remote control button may vary depending on your region/country/TV model.

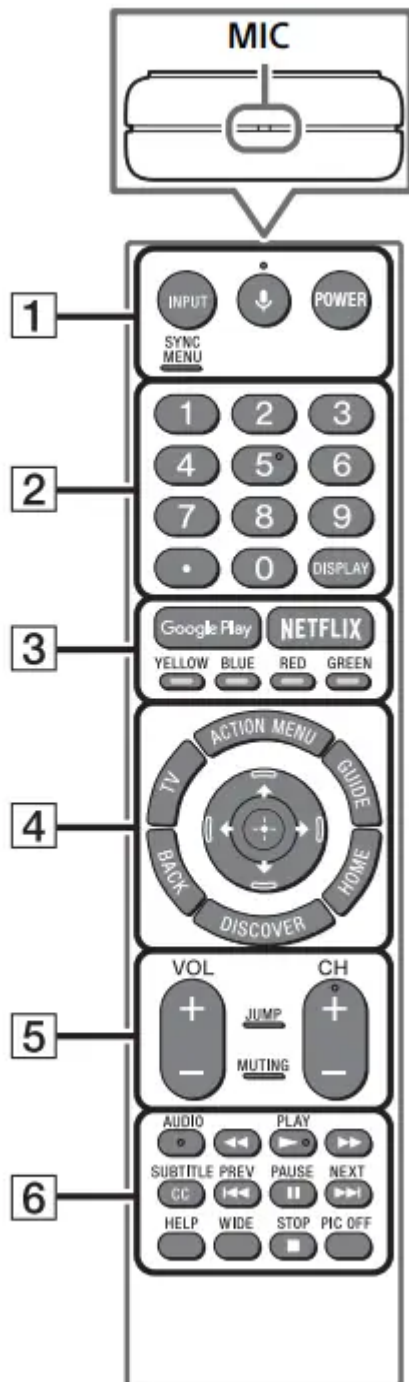

1. INPUT: Display and select the input source.

-  (Microphone): Use Voice Function. (e.g., Search various content by voice.)
- POWER: Turn on or turn off the TV (standby mode).
- SYNC MENU: Display the BRAVIA Sync Menu.

2. Number buttons

-  : Use with the 0-9 buttons to select digital channels.

- DISPLAY: Display information about the channel/ program/input you are viewing.
3. Google Play: Access the “Google Play” online service.
- NETFLIX (Only on limited region/ country/TV model): Access the “NETFLIX” online service.
  - Color buttons: Execute corresponding function at that time.
4. ACTION MENU: Display a list of contextual functions.
- TV
  - Switch to a TV channel or input from other applications. Turn on the TV to display TV channel or input.
  - GUIDE: Display the digital program guide.
  - BACK: Return to previous screen.
  - HOME: Display the TV Home Menu.
  - DISCOVER: Bring up the Content Bar to search for content.



5. VOL +/- (Volume): Adjust the volume.
- JUMP: Jump back and forth between two channels or inputs. The TV alternates between the current channel or input and the last channel or input that was selected.
  - MUTING: Mute the sound. Press again to restore the sound.
  - CH +/- (Channel): Select the channel.
6. AUDIO: Change the language for the program currently being viewed.
- : Operate media contents on TV and connected BRAVIA Sync-compatible device.
  - SUBTITLE/CC: Turn subtitles on or off (when the feature is available). Display Help menu. Help Guide can be accessed from here.
  - WIDE: Change the screen format.
  - PIC OFF: Turn the picture off, while sound remains on.

### Guidelines for IR Remote Control

- Point your remote control directly at the IR sensor located on your TV.
- Make sure that no objects are blocking the path between the remote control and the IR sensor on your TV.

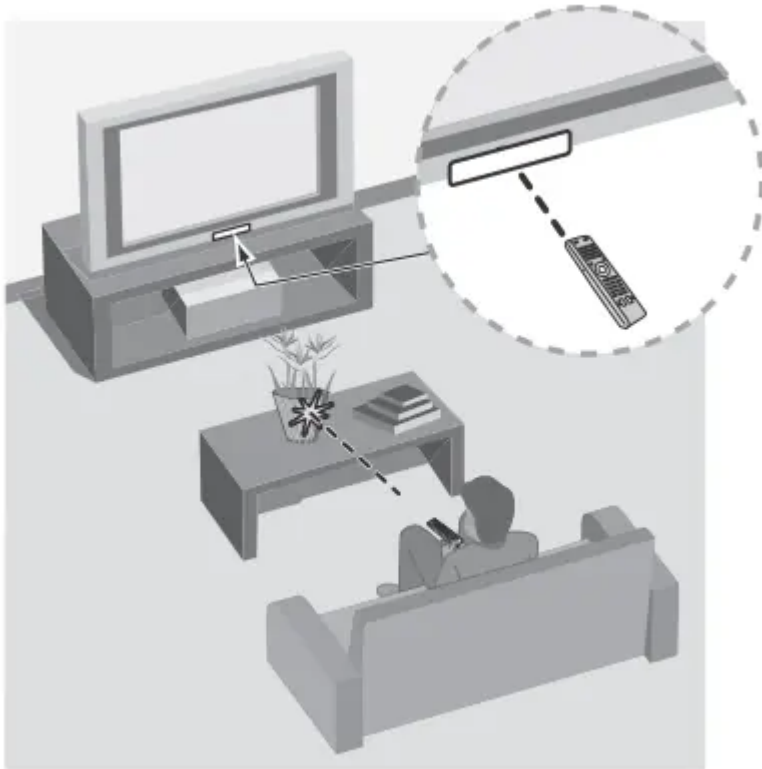

- Fluorescent lamps can interfere with your remote control; try turning off the fluorescent lamps.
- If you are having problems with the remote control, reinsert or replace your batteries and make sure that they are correctly inserted.

## Connection Diagram

For more information on connections, refer to the Help Guide by pressing HELP on the remote control.

Note: When connecting the cable to the Cable/Antenna input, finger tighten only, over tightening the connection can damage the TV.

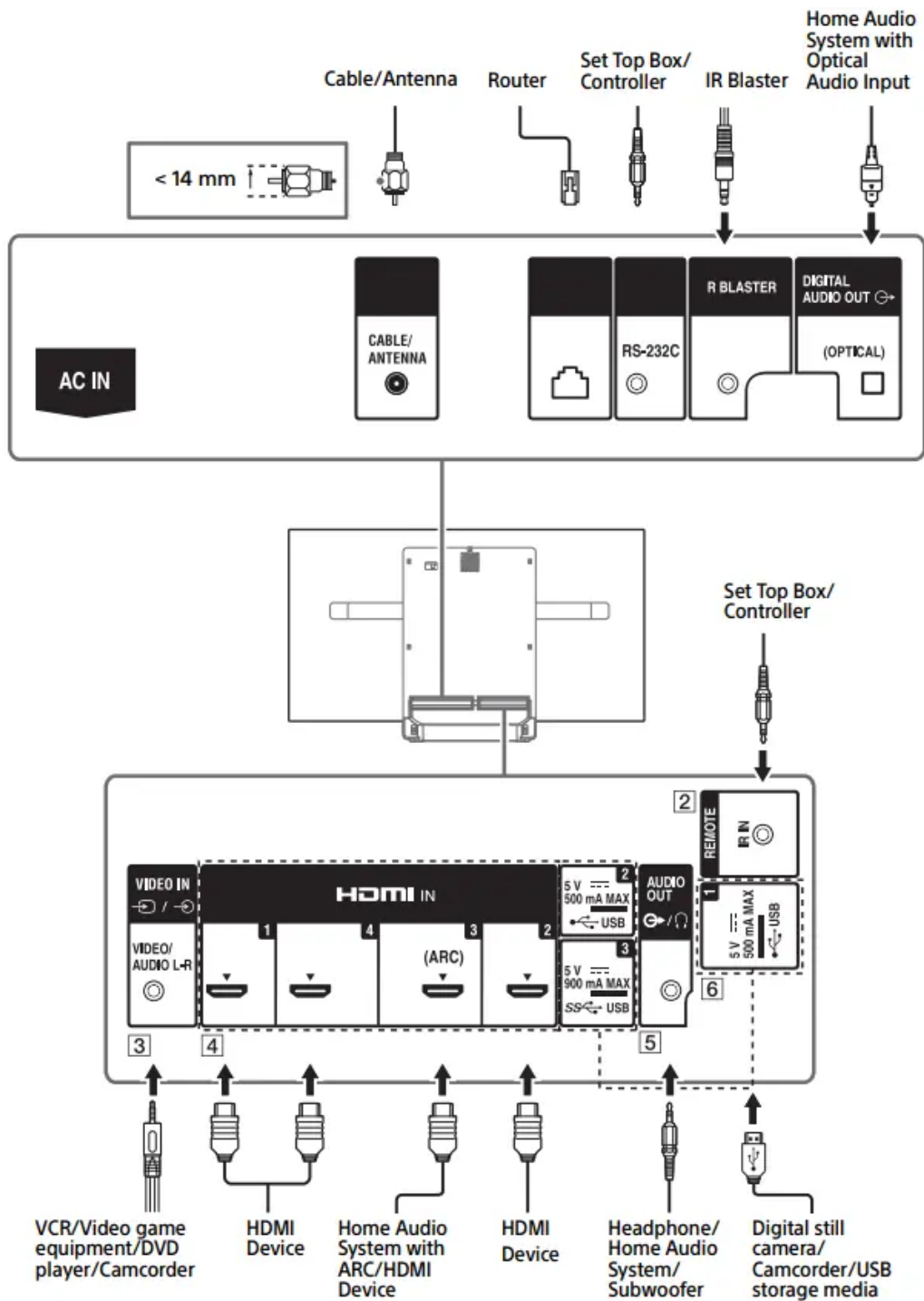

1. IR BLASTER\*

2. REMOTE RS-232C REMOTE IR IN

- These jacks are for receiving the external control signal. Enables extended control of the TV using RS232C via the RS-232C and IR IN jacks. RS-232C: connect to the RS-232C terminal of the home controller. IR IN: connect to the IR out terminal of the home controller.
- Take care to not connect to headphones or an external audio system.

### 3. VIDEO IN

- For a composite connection, use an Analog Extension Cable (not supplied)

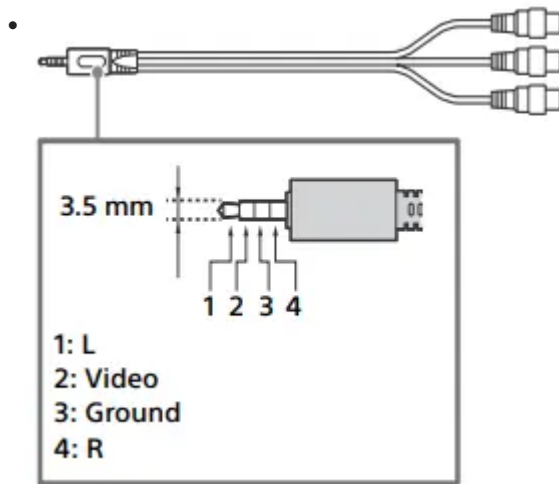

### 4. HDMI IN 1/2/3/4

- If connecting a digital audio system that is compatible with Audio Return Channel (ARC) technology, use HDMI IN 3. If not, an additional connection with DIGITAL AUDIO OUT (OPTICAL) is necessary.

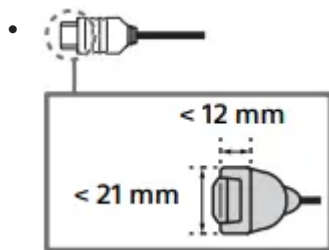

### 5. AUDIO OUT

- Supports 3-pole stereo mini jack only.
- To listen to the TV's sound through the connected equipment, press HOME. Select [Settings] → [Sound] → [Headphone/Audio out] and then select the desired item.

### 6. USB 1/2, USB 3

- Connecting a large USB device may interfere with other connected devices beside it.
- When connecting a large USB device, connect to the USB 1 port.

\* Only on limited region/country/TV model.

Note: Be sure to store the side cover in a safe place for future use.

## Installing the TV to the Wall

This TV's instruction manual only shows the steps on preparing the installation of the TV before installing to the wall.

Your TV can be mounted on a wall using a Wall-Mount Bracket (not supplied) out of the box as packaged. If the Table-Top Stand is attached to the TV, the TV may require detaching the Table-Top Stand; see page 18 (Detaching the Table-Top Stand from the TV). Prepare the TV for the Wall-Mount Bracket before making cable connections.

**For product protection and safety reasons, Sony strongly recommends that installation of your TV on the wall be performed by qualified professionals. Do not attempt to install it yourself.**

- Follow the instruction guide provided with the Wall-Mount Bracket for your model. Sufficient expertise is required in installing this TV, especially to determine the strength of the wall for withstanding the TV's weight.
- The length of the screw for Wall-Mount Bracket differs depending on the Wall-Mount Bracket thickness. Please see below illustration.

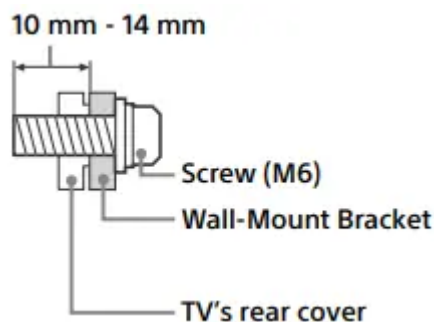

- Be sure to store the unused screws and Table-Top Stand in a safe place until you are ready to attach the Table-Top Stand. Keep the screws away from small children.

### Note

- Read the supplied Safety Booklet for additional safety information.
- Be sure to hold the TV while preparing it for wall-mount installation.
- Please remove the corner guards after installing the TV to the wall.

## Installing the TV to the Wall from Carton

1. Attach WM1 and WM2 (supplied with the TV) to the rear of the TV.

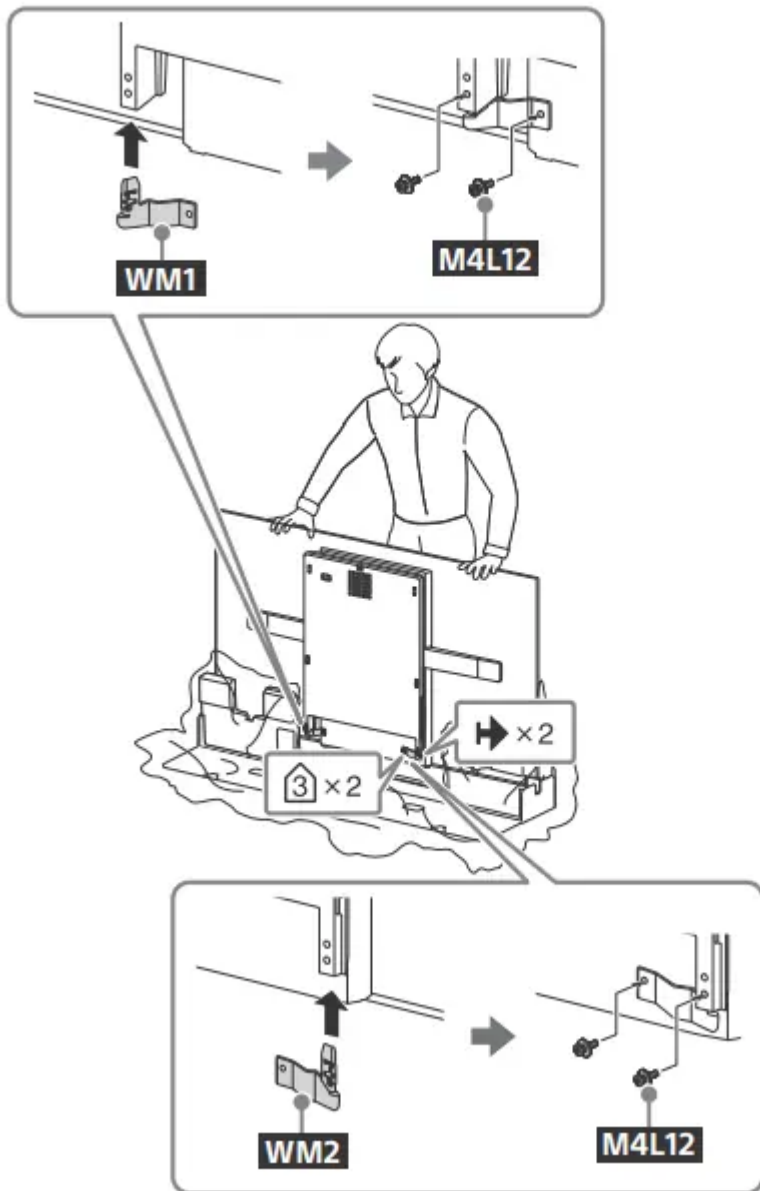

2. Attach the Wall-Mount Bracket (not supplied) using the screws (not supplied).



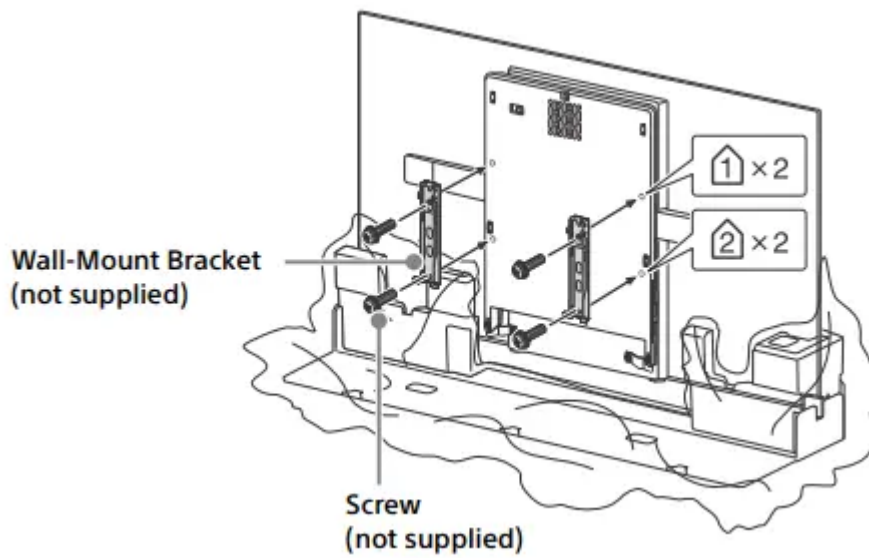

Note: If using an electric screwdriver, set the torque at approximately 1.5 N·m {15 kgf·cm}.

## Installing the TV to the Wall from Table-Top Stand

1. Insert the corner guards.

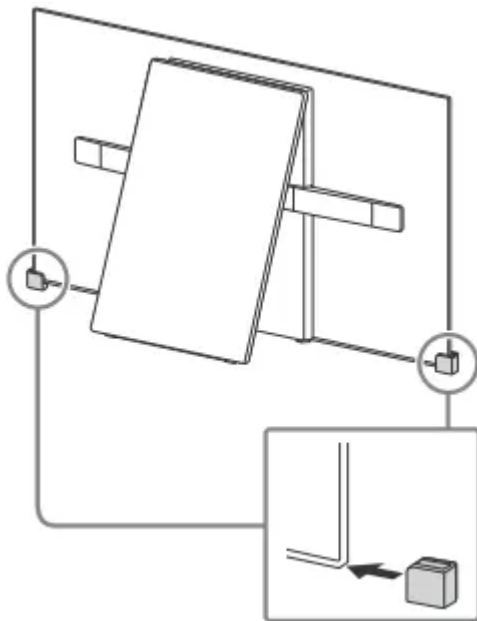

2. Remove the center cover.

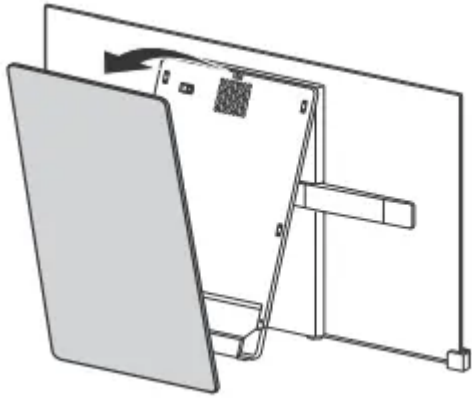

3. Remove the screws.

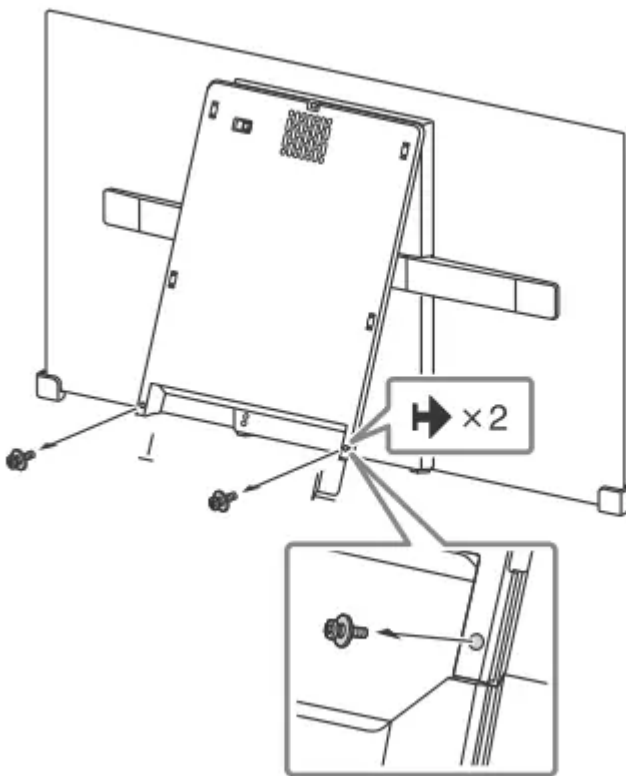

4. Detach the stand base.

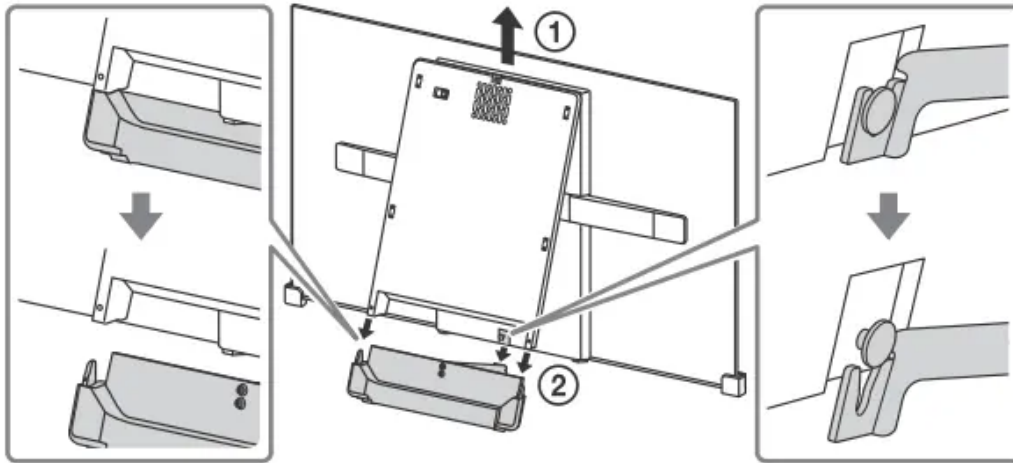

5. Close the center block by releasing the hinge lock.

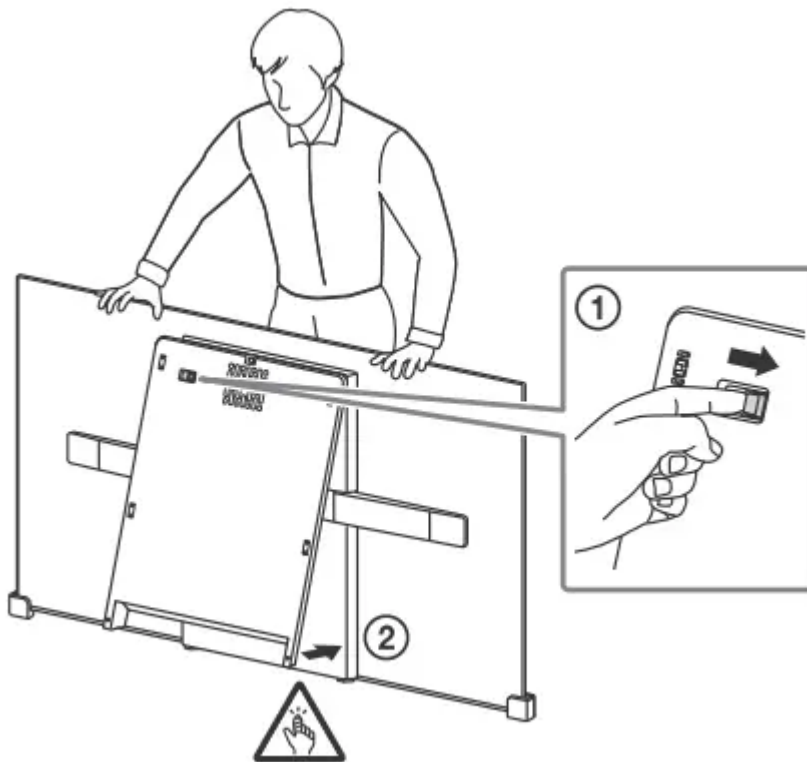

6. Detach SS from SB .

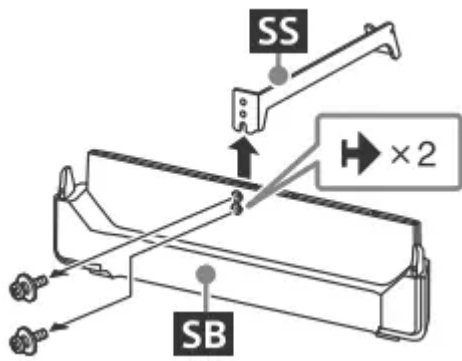

7. Attach WM1 and WM2 (supplied with the TV) to the rear of the TV.

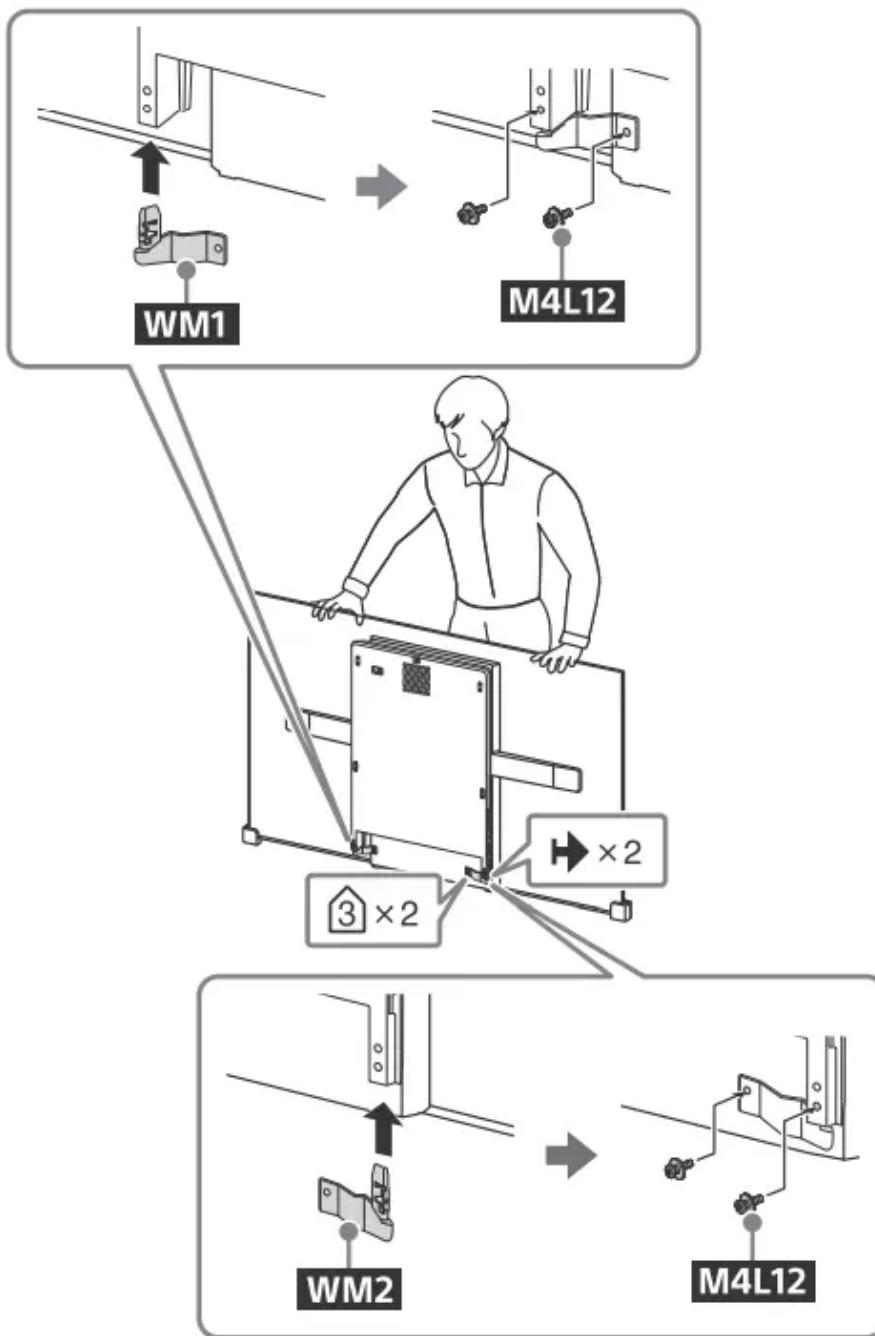

8. Attach the Wall-Mount Bracket (not supplied) using the screws (not supplied).

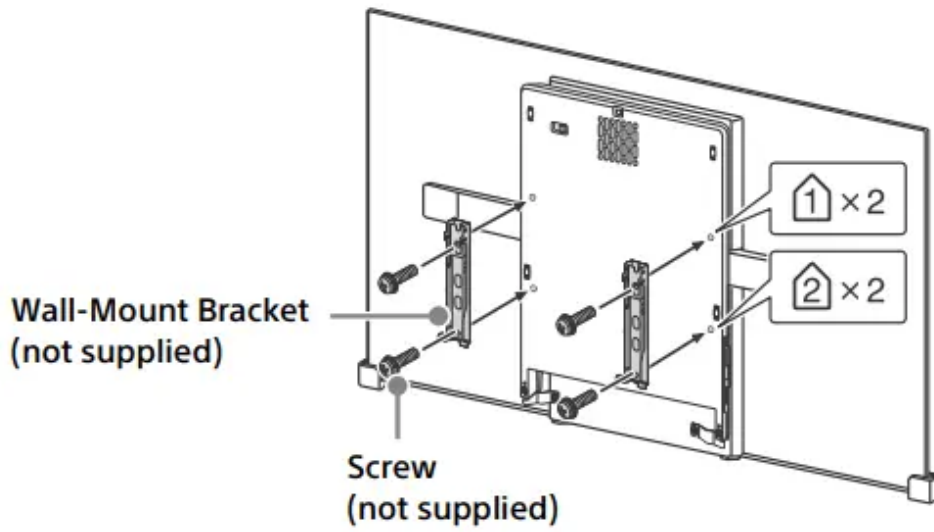

Note: If using an electric screwdriver, set the torque at approximately 1.5 N·m {15 kgf·cm}.

#### Detaching the Table-Top Stand from the TV

To detach the Table-Top Stand from the TV, remove the screws .

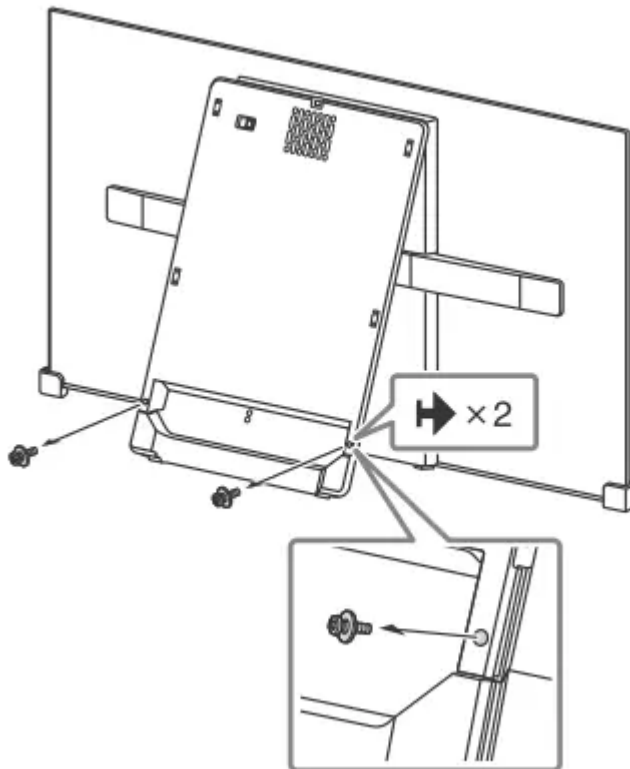

Note

- Do not remove the Table-Top Stand for any reason other than to install corresponding accessories on the TV.

- Be sure the TV is vertical before turning on. To avoid uneven picture uniformity do not power on the TV with the panel facing down.
- When attaching the Table-Top Stand again, be sure to fasten the screws (previously removed) to the original holes on the rear of the TV.

## Installing the TV against a wall or enclosed area

### Ventilation

- Never cover the ventilation holes or insert anything in the cabinet.
- Leave space around the TV set as shown below.

### Installed with stand

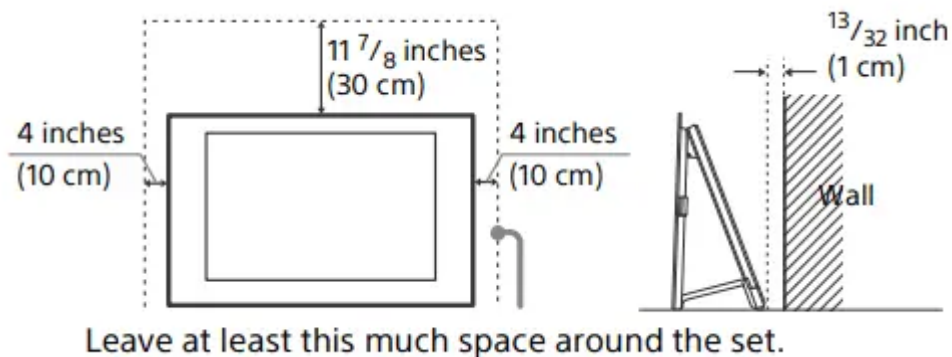

### Installed on the wall

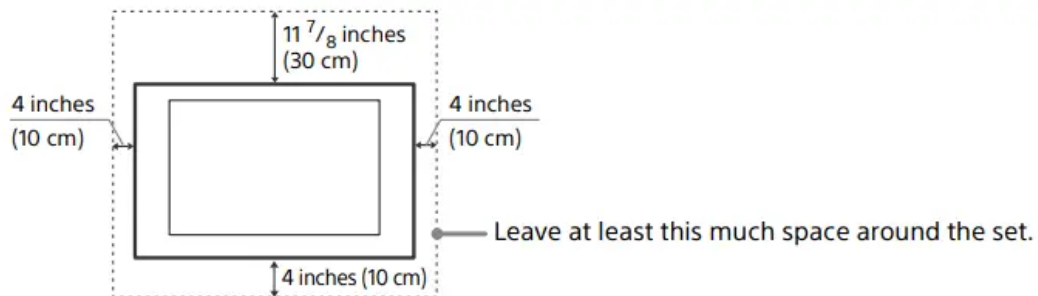

Never install the TV set as follows:

Air circulation is blocked.      Air circulation is blocked.

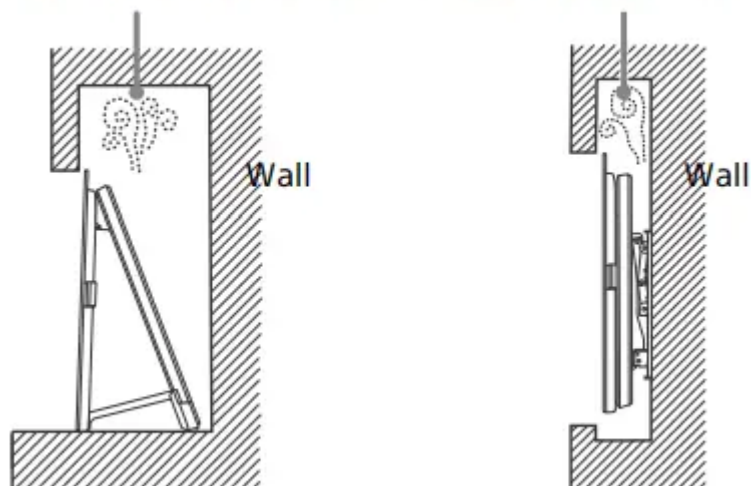

Note: Inadequate ventilation can lead to overheating of the TV and may cause damage to your TV or cause a fire.

## Troubleshooting

General troubleshooting for issues like: black screen, no sound, frozen picture, TV does not respond, or network is lost, do the following steps.

1. Restart your TV by pressing the power button on the remote control until a message appears. The TV will restart. If the TV does not recover, try unplugging the TV from the AC power cord for three minutes and then plug it in again.
2. Refer to the Help menu by pressing HELP on the remote control.
3. Connect your TV to the Internet and perform a software update.
4. Visit Sony support website (information provided on the front cover).
5. Perform the factory data reset. Refer to “How to reset the TV to factory settings” (page 20).

### **When [A new TV system software update is available...] message is displayed.**

Sony strongly recommends you to update the TV software by selecting [Update Now]. These software updates improve your TV performance or add new features. The following screen with [Updating...] will appear and the illumination LED flashes white while software is updating.

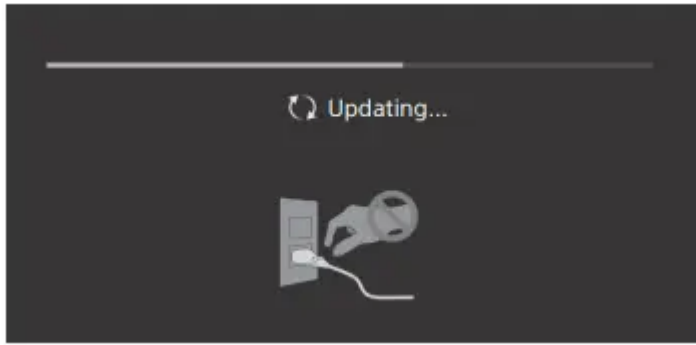



Do not unplug the AC power cord during the software update. If you do, the software update may not finish completely, and it may cause a software malfunction. Software updates can take up to 15 minutes.

**When you plug in TV, the TV may not be able to turn on for a while even if you press the power button on the remote control or the TV.**

It takes time to initialize the system. Wait for about one minute, then operate it again.

### **How to reset the TV to factory settings**

**WARNING:** The reset will clear all of your customized settings including the parental lock for broadcast setting.

- Turn on the TV. You can reset the TV to factory settings by pressing HOME, then select [Settings] → [Storage & reset] → [Factory data reset].
- To force factory data reset, unplug the AC power cord. Press and hold both  and  buttons on the TV, then plug in the AC power cord. Release both buttons when the illumination LED blinks in green.
- For security purposes, be sure to remove all personal and account information before discarding, selling or passing your TV to someone else by: unlinking/unregistering, signing out of and deactivating all network services as well as factory reset the TV.

## **Troubles and Solutions**

### **When the illumination LED is flashing in red.**

Count how many times it flashes (interval time is three seconds). Reboot the TV by disconnecting the AC power cord from the TV for three minutes, then turn on the TV. If the problem persists, disconnect the AC power cord, and contact Sony Customer Support (information provided on the front cover) with the number of times the illumination LED flashes.

### **There is no picture (screen is dark) and no sound.**

- Check the cable/antenna connection.
- Connect the TV to AC power, and press the  button on the TV or POWER button on the remote control.

**Some programs cannot be tuned.**

- Check the cable/antenna connection.

**The remote control does not function.**

- Replace the batteries.

**The parental lock for broadcast password has been forgotten.**

- Enter 4357 for the password and select [Change PIN]. The restricted profile password has been forgotten.
- Perform the force factory data reset. Refer to “How to reset the TV to factory settings” (page 20).

**The TV and its surroundings become warm.**

- When the TV is used for an extended period of time, the TV and its surroundings may become warm to the touch. This is not a malfunction of the TV.

**The screen becomes darker while watching TV.**

- If the whole image or part of the image remains still, the screen brightness will be gradually reduced to prevent image retention. This is not a malfunction of the TV.

**You are concerned about image retention.**

- If the same image is displayed repeatedly or for long periods of time, image retention may occur. You can manually perform a Panel refresh to reduce image retention.

**Note**

- Perform Panel refresh only when image retention is particularly noticeable. As a reference, perform it only once a year. Avoid performing it more than once a year because it may affect the usable life of the panel.
- Images that include clocks, logos and bright colors (including white) easily cause image retention. Avoid displaying these types of images for long periods of time, otherwise image retention may occur.

**A white line appears on the screen.**

- Panel refresh automatically runs after the TV has been used for long periods of time to reduce image retention. Panel refresh starts after the TV is turned off and takes about one hour to complete. A white line may be displayed on the screen during the Panel refresh. This is not a malfunction of the TV.

**The message [Panel refresh did not finish...] is displayed.**

Panel refresh automatically runs after the TV has been used for long periods of time to reduce image retention. If the TV is turned on, the AC power cord is unplugged, or the room temperature

falls outside of the range between 50 °F and 104 °F (10 °C and 40 °C) during the Panel refresh, the process will not be completed and this message will appear.

- If Panel refresh started automatically, it will restart when you turn off the TV with the remote control.
- If Panel refresh initiated manually, you must select it again

### **Warning**

This content is compiled from multiple sources and is provided for reference purposes only. It may not be complete or fully applicable to all situations. If you are unable to resolve your issue, please contact the product manufacturer or an authorized service provider for official support.