

## INSTALLATION INSTRUCTIONS

### Water Supply Requirements

Gather the required tools and parts before starting installation.

Read and follow the instructions provided with any tools listed here.

#### TOOLS NEEDED:

- Flat-blade screwdriver
- $\frac{7}{16}$ " and  $\frac{1}{2}$ " Open-end or two adjustable wrenches
- $\frac{1}{4}$ " Nut driver
- $\frac{1}{4}$ " Drill bit
- Cordless drill

#### IMPORTANT:

- All installations must meet local plumbing code requirements.
- Do not use a piercing-type or  $\frac{3}{16}$ " (4.76 mm) saddle valve which reduces water flow and clogs more easily.
- Use copper tubing and check for leaks. Install copper tubing only in areas where the household temperatures will remain above freezing.
- For models with water filters, the disposable water filter should be replaced at least every 6 months.

### Water Pressure

A cold water supply with water pressure between 35 and 120 psi (241 and 827 kPa) is required to operate the water dispenser and ice maker. If you have questions about your water pressure, call a licensed, qualified plumber

### *Reverse Osmosis Water Supply*

IMPORTANT: The pressure of the water supply coming out of a reverse osmosis system going to the water inlet valve of the refrigerator needs to be between 35 and 120 psi (241 and 827 kPa).

If a reverse osmosis water filtration system is connected to your cold water supply, the water pressure to the reverse osmosis system needs to be a minimum of 40 to 60 psi (276 to 414 kPa).

If the water pressure to the reverse osmosis system is less than 40 to 60 psi (276 to 414 kPa):

- Check to see whether the sediment filter in the reverse osmosis system is blocked. Replace the filter if necessary.
- Allow the storage tank on the reverse osmosis system to refill after heavy usage.

- If your refrigerator has a water filter, it may further reduce the water pressure when used in conjunction with a reverse osmosis system. Remove the water filter. See “Water Filtration System.”

If you have questions about your water pressure, call a licensed, qualified plumber.

## **Connect the Water Supply**

Read all directions before you begin.

**IMPORTANT:** If you turn on the refrigerator before the water line is connected, turn off the ice maker to avoid excessive noise or damage to the water line.

### **Connect to Water Line**

1. Unplug refrigerator or disconnect power.
2. Turn off main water supply. Turn on nearest faucet long enough to clear line of water.
3. Find a ½" to 1¼" (12.7 mm to 31.8 mm) vertical cold water pipe near the refrigerator.

**IMPORTANT:**

- Make sure it is a cold water pipe.
  - Horizontal pipe will work, but the following procedure must be followed: Drill on the top side of the pipe, not the bottom. This will help keep water away from the drill. This also keeps normal sediment from collecting in the valve.
4. Determine the length of copper tubing you need. Measure from the connection on the lower right rear of the refrigerator to the water pipe. Add 7 ft (2.1 m) to allow for cleaning. Use ¼" (6.35 mm) O.D. (outside diameter) copper tubing. Be sure both ends of copper tubing are cut square.
  5. Using a cordless drill, drill a ¼" hole in the cold water pipe you have selected
  6. Fasten the shut-off valve to the cold water pipe with the pipe clamp. Be sure the outlet end is solidly in the ¼" drilled hole in the water pipe and that the washer is under the pipe clamp. Tighten the packing nut. Tighten the pipe clamp screws slowly and evenly so the washer makes a watertight seal. Do not overtighten.
  7. Slip the compression sleeve and compression nut on the copper tubing as shown. Insert the end of the tubing into the outlet end squarely as far as it will go. Screw compression nut onto outlet end with adjustable wrench. Do not overtighten or you may crush the copper tubing.
  8. Place the free end of the tubing in a container or sink, and turn on the main water supply. Flush the tubing until water is clear. Turn off the shut-off valve on the water pipe.

### **Connect to Refrigerator**

1. Create a service loop (minimum diameter of 2 ft [61 cm]) with the copper tubing. Avoid kinks when coiling the copper tubing.
2. Remove the plastic cap from water valve inlet port. Place a compression nut and sleeve on the copper tubing.
3. Insert the end of the copper tubing into the water valve inlet port. Shape tubing slightly so that the tubing feeds straight into the port to avoid kinks.
4. Slide the compression nut over the sleeve and screw into the water valve inlet port.

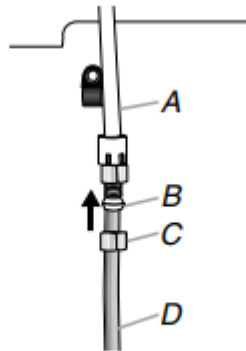

A. Plastic water tubing  
B. Sleeve  
C. Compression nut  
D. Copper tubing

5. Using an adjustable wrench, hold the nut on the plastic water line to keep it from moving. Then, with a second wrench turn the compression nut on the copper tubing counterclockwise to completely tighten. Do not overtighten.

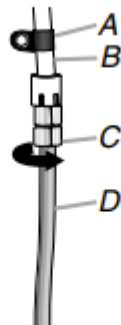

A. "P" clamp  
B. Plastic water line  
C. Compression nut  
D. Copper tubing

6. Check connection by pulling on copper tubing. Attach copper tubing to refrigerator cabinet with a "P" clamp. Turn on water supply to refrigerator and check for leaks. Correct any leaks.

### Complete the Installation

1. Plug into a grounded 3 prong outlet.

NOTE: Allow 24 hours to produce the first batch of ice. Discard the first three batches of ice produced. Allow 3 days to completely fill the ice container

## Refrigerator Doors and Drawer

All graphics referenced in the following instructions are included later in this section after “Final Steps.”

### Remove and Replace Handles

#### Style 1

1. Using a 3/32" or 1/8" hex key, loosen the two setscrews located on the side of each handle. See Style 1 Handle graphics 1 and 2.
2. Pull the handle straight out from the door. Make sure you keep the screws for reattaching the handles.
3. To replace the handles, reverse the directions.

#### Style 2

To Remove Handles:

1. Grasp the lower part of the handle firmly, slide the handle up and pull the handle straight out from the door. See Style 2 Handle graphics 1 and 2.

To Replace Handles:

1. Position the handle so that the large holes in the mounting clips are down and align the holes with the door studs.
2. Rotate the handle so that the mounting clips are flat against the door and slide the handle down to engage. See Style 2 Handle graphics 1 and 2.

### Remove Doors and Hinges

IMPORTANT:

- Remove food and any adjustable door or utility bins from doors.
- Keep the refrigerator doors closed until you are ready to lift them free from the cabinet.

NOTE: Provide additional support for the refrigerator door while the hinges are being removed. Do not depend on the door gasket magnets to hold the door in place while you are working.

TOOLS NEEDED: W, VS hex-head socket wrench, Torxet

T20 screwdriver, #2 Phillips screwdriver, and a flat-blade screwdriver.

1. Unplug refrigerator or disconnect power.
2. Remove the base grille. Grasp the grille firmly and pull it toward you.

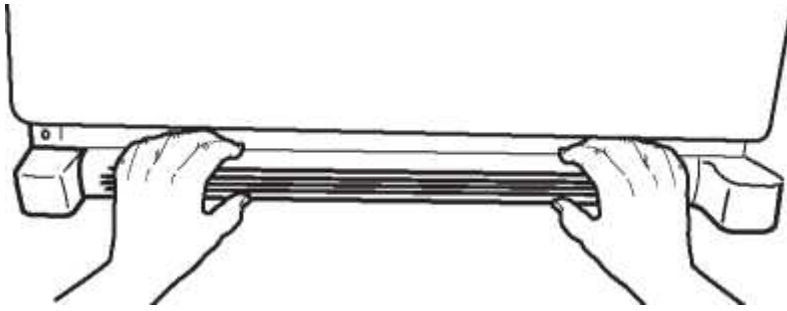

3. Starting with the right-hand side door, remove the parts for the top hinge as shown in Top Hinge graphic. Lift the refrigerator door from the bottom hinge pin.
4. Remove top hinge cover from left side refrigerator door. Disconnect the wiring plug located on top of the hinge by wedging a flat-blade screwdriver or your fingernail between the two sections. See Connections graphic.
5. Disconnect the water line by pulling back on the locking collar while pulling the water line out of the water line connector. See Connections graphic.
6. Remove the parts for the top hinge as shown in Top Hinge graphic. Lift the left-hand side door from the bottom hinge pin.
7. Using a  $\frac{5}{8}$ " hex wrench, remove the leveling leg brackets from the bottom of the cabinet. Keep screws for later use.

### **Replace Doors and Hinges**

1. Assemble the parts for the top hinge as shown in Top Hinge graphic. Do not tighten the screws completely.
2. Replace the parts for the bottom hinge as shown in Bottom Hinge graphic. Tighten screws. Replace the refrigerator door. NOTE: Provide additional support for the refrigerator door while the hinges are being moved. Do not depend on the door gasket magnets to hold the door in place while you are working.
3. Align the door so that the bottom of the refrigerator door aligns evenly with the top of the freezer drawer. Tighten all screws.
4. Reconnect the wiring plug on top of the left-hand side refrigerator door
5. Reconnect the water line by pulling back the locking collar ring while firmly pushing the water line into the connector.
6. Check for leaks. Replace the top hinge covers

### **Remove and Replace Freezer Drawer**

IMPORTANT: Two people may be required to remove and replace the freezer drawer. Graphics are included later in this section.

#### ***Remove Drawer Front***

1. Open the freezer drawer to full extension.

2. Loosen the four screws attaching the drawer glides to the drawer front. See Drawer Front Removal graphic.

NOTE: Loosen screws three to four turns. Keep the screws in the drawer front.

3. Lift drawer front upward and off the screws. See Drawer Front Removal graphic.

### **Replace Drawer Front**

1. Slide the drawer glides out of the freezer compartment. Insert the screws in the top of the drawer front into the slots in the drawer brackets. See Drawer Front Replacement graphic.

2. Pull the drawer brackets toward you to position the two screws in the bottom of the drawer front into the brackets. See Drawer Front Replacement graphic.

3. Completely tighten the four screws.

### **Final Steps**

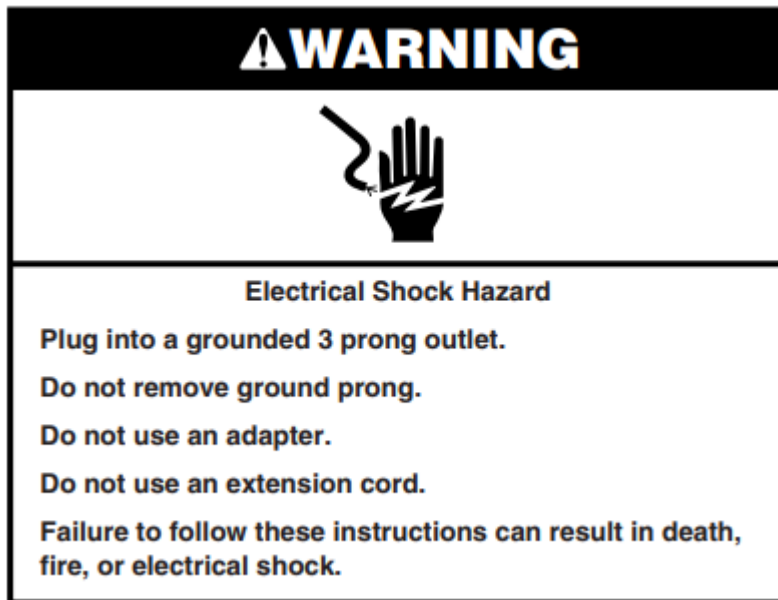

1. Replace the base grille.

2. Plug into a grounded 3 prong outlet.

3. Return all removable parts to doors and drawer and food to refrigerator and freezer.

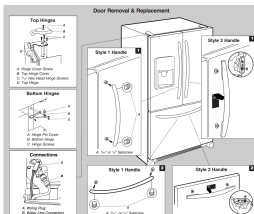

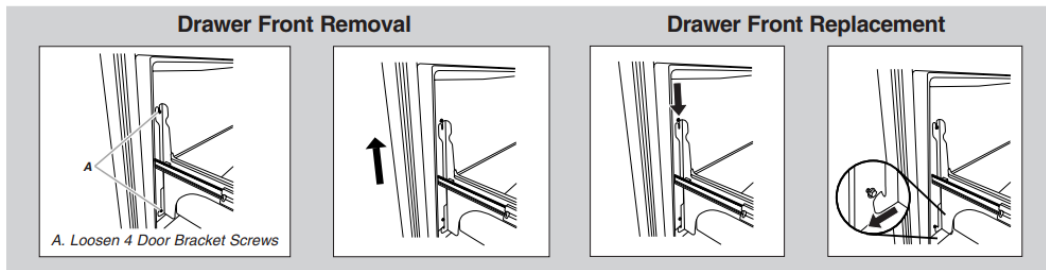

## Adjust the Doors

1. Remove the base grille. Grasp the grille firmly and pull it toward you.

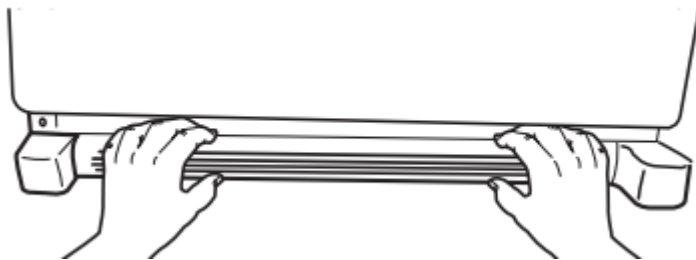

2. Raise or lower the cabinet.

Using a 1/8" hex driver, turn the leveling screw on each side to raise or lower that side of the refrigerator.

**NOTE:** Having someone push against the top of the refrigerator takes some weight off the leveling screws. This makes it easier to turn the screws. It may take several turns of the leveling screw to adjust the tilt of the refrigerator.

- To raise, turn the leveling screw clockwise.
- To lower, turn the leveling screw counterclockwise.

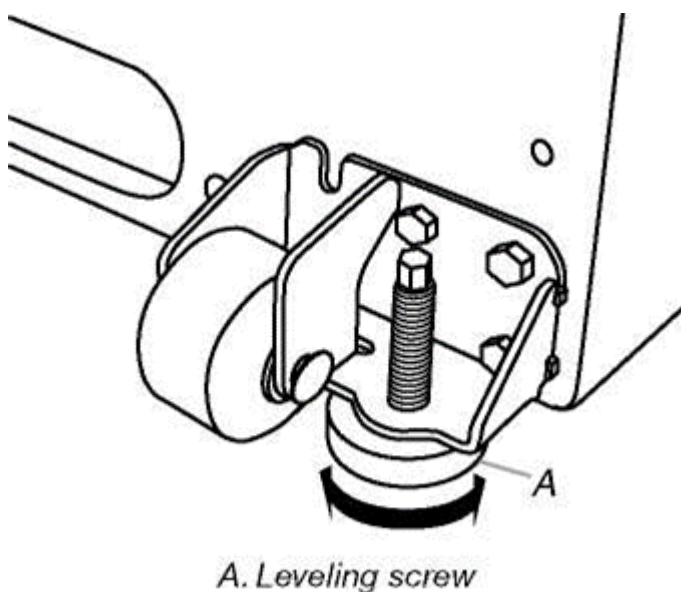

3. Open the door again to make sure that it closes as easily as you like. If not, tilt the refrigerator slightly more to the rear by turning both leveling screws clockwise. It may take several more turns, and you should turn both screws the same amount.

4. Replace the base grille.

## REFRIGERATOR USE

### Opening and Closing Doors

There are two refrigerator compartment doors. The doors can be opened and closed either separately or together.

There is a vertically-hinged seal on the left refrigerator door.

- When the left side door is opened, the hinged seal automatically folds inward so that it is out of the way.
- When both doors are closed, the hinged seal automatically forms a seal between the two doors.

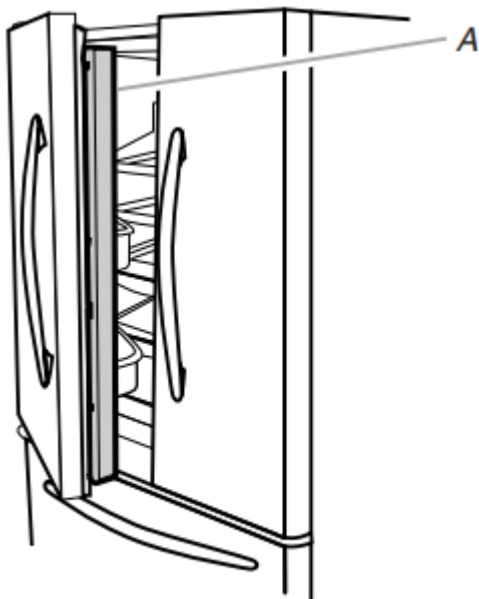

*A. Hinged seal*

### Using the Controls

The control center is located on the front of the ice and water dispenser.

### Temperature Controls

For your convenience, your temperature controls are preset at the factory. When you first install your refrigerator, make sure the controls are still set to the recommended set points as shown.

## Recommended Setting

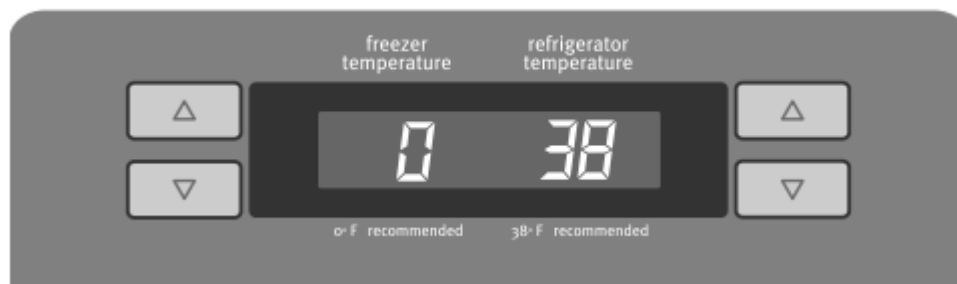

### IMPORTANT:

- When the power is on, the temperature display shows the set point temperature of the compartment.
- Wait 24 hours for your refrigerator to cool completely before adding food. If you add food before the refrigerator has cooled completely, your food may spoil.

**NOTE:** Adjusting the refrigerator and freezer temperature controls to a colder than recommended setting will not cool the compartments any faster.

- The recommended settings should be correct for normal household refrigerator use. The controls are set correctly when milk or juice is as cold as you like and when ice cream is firm.
- If the temperature is too warm or too cold in the refrigerator or freezer, first check the air vents to be sure they are not blocked before adjusting the controls.

### Adjusting Controls

The REFRIGERATOR control adjusts the refrigerator compartment temperature. The FREEZER control adjusts the freezer compartment temperature.

If you need to adjust the temperature in either the refrigerator or freezer compartment, use the settings listed in the chart as a guide.

#### ***To Adjust Set Point Temperatures:***

The first touch of the up or down arrow touch pad displays the current temperature set point.

- Press the up or down arrow touch pads until the desired temperature set point is displayed.

**NOTE:** Except when first turning on the refrigerator, do not adjust either temperature control more than one setting at a time. Wait 24 hours between adjustments for the temperature to stabilize.

| <b>CONDITION/REASON:</b>        | <b>ADJUSTMENT:</b>             |
|---------------------------------|--------------------------------|
| REFRIGERATOR too warm           | REFRIGERATOR Control 1° lower  |
| FREEZER too warm/too little ice | FREEZER Control 1° lower       |
| REFRIGERATOR too cold           | REFRIGERATOR Control 1° higher |
| FREEZER too cold                | FREEZER Control 1° higher      |

## Cooling On/Off

IMPORTANT:

- Depending on your model you may have a control center with an On/Off button (**Style 1**), or you may have a control center without an On/Off button (**Style 2**).
- The On/Off control turns off cooling for both compartments and turns off the dispenser. It does not disconnect power to the refrigerator.

Style 1 - Press and hold the On/Off button for three seconds. The red LED will light up to indicate that cooling is Off. Press the On/Off button again to turn on the cooling. The LED will turn off.



Style 2 – Press the Freezer up arrow touch pad until OFF appears in the display. Neither compartment will cool. Press the Freezer or Refrigerator down arrow touch pad to turn the cooling back on.

## Additional Control Center Features

### **Fast Cool**

The Fast Cool feature assists with periods of high refrigerator use, full grocery loads, or temporarily warm room temperatures.

- Press the Fast Cool touch pad to set the freezer and refrigerator to the lowest temperature settings. Press the Fast Cool touch pad again to return to the normal refrigerator set point.

**NOTE:** The Fast Cool feature will automatically shut off in approximately 2 hours. When fast cool is on, the temperature cannot be adjusted.

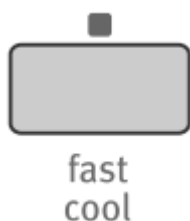

### ***Humidity Control (on some models)***

The Humidity Control feature turns on a heater to help reduce moisture on the door hinge seal. Use in humid environments or when you notice moisture on the door hinge seal. The refrigerator uses more energy when Humidity Control is on.

- Press Humidity Control to turn on the door heater. Press Humidity Control again to turn off the heater. The LED will be illuminated when Humidity Control is on.



### ***Temp Alarm***

The Temp Alarm feature provides temperature information in the event of a power outage.

Power outage: During a power outage, if the temperatures in the refrigerator and freezer compartments exceed normal operating temperatures, the highest temperature reached will be displayed.

- Press the Temp Alarm touch pad until the indicator light is lit, to turn on this feature. Press and hold Temp Alarm for 3 seconds until the indicator light goes off to turn off this feature.

Temperature alarm: An alarm will sound repeatedly if the freezer or refrigerator compartment temperatures exceed normal operating temperatures for an hour or more.

The temperature displays will alternately show the current temperatures and the highest temperatures the compartments reached.

- Press the Temp Alarm touch pad once to stop the audible alarm and alternating temperature displays. The Temp Alarm light will continue to flash until the refrigerator returns to the set temperature.

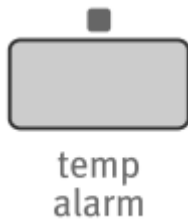

### **Door Alarm**

The Door Alarm feature sounds a chime every few seconds when the refrigerator door has been left open for 5 continuous minutes. The chime will sound until the door is closed or Door Alarm is turned off.

- Press the Door Alarm touch pad to turn this feature on or off. The indicator light will be lit when the Door Alarm feature is on.



### **Filter Reset**

See "Water Filtration System."

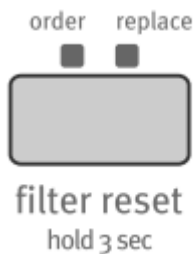

### **User Preferences**

The control center allows you to set user preferences, if desired.

#### **Temperature Display (F\_C)**

This preference allows you to change the temperature display.

F - Temperature in degrees Fahrenheit

C - Temperature in degrees Celsius

#### **Alarm (AL)**

This preference allows you to turn off the sound of all alarms.

ON - You will hear the alarm sound.

OFF - You will not hear the alarm sound.

### ***Auto Light Level Selection (LL)***

This preference allows you to adjust the dispenser light level from dimmest to brightest (settings 1 through 9).

**NOTE:** The Auto Light feature on the control center must be selected to activate this preference.

### ***Sabbath Mode (SAB)***

ON - All control center lights, interior lights and alarm tones will be disabled.

OFF - All control center lights, interior lights and alarm tones will be enabled.

**NOTE:** Press the door alarm touch pad for 3 seconds to restore all lights.

### ***To Access the User Preferences Menu:***

1. Press and hold the Door Alarm touch pad for three seconds. The preference name will appear in the Freezer display and the preference status (F or C) or (ON or OFF) will appear in the Refrigerator display.
2. Use the Freezer up or down arrow touch pads to scroll through the preference names. When the desired preference name is displayed, press the Refrigerator up or down arrow touch pads to change the preference status.
3. Set your preferences by pressing and holding the Door Alarm touch pad for 3 seconds.

## **Crisper Humidity Control**

You can control the amount of humidity in the moisture-sealed crisper. Depending on your model, adjust the control to any setting between FRUIT and VEGETABLES or LOW and HIGH.

**FRUIT/LOW** (open) for best storage of fruits and vegetables with skins.

**VEGETABLES/HIGH** (closed) for best storage of fresh, leafy vegetables.

## **Ice Maker and Ice Storage Bin**

### **IMPORTANT:**

- Flush the water system before turning on the ice maker. See “Water and Ice Dispenser.”
- The ice maker and storage bin are located in the upper left-hand side of the refrigerator compartment.

### **Turning the Ice Maker On/Off**

The On/Off switch is located on the ice maker.

To turn on the ice maker, press the switch to the ON position.

To manually turn off the ice maker, press the switch to the OFF position.

NOTE: Your ice maker has an automatic shutoff. The ice maker sensors will automatically stop ice production, but the control will remain in the ON position.

### Removing and Replacing Ice Storage Bin

To Remove the Ice Storage Bin:

1. Hold the base of the storage bin and press the release button on the lower right.
  2. Pull the storage bin out until resistance is felt. Lift up the front of the ice bin and remove.
  3. Press the switch to the OFF position
- To Replace the Ice Storage Bin:

IMPORTANT: It may be necessary to turn the auger driver, behind the ice bin, counterclockwise to properly align the ice bin with the auger driver. The ice storage bin must be locked in place for proper ice dispensing.

1. Press the switch to the ON position
2. Slide the ice bin into the guide rails located on either side of the enclosure.
3. Push the ice bin in until resistance is felt. Raise the front slightly and push the ice bin in until an audible “click” is heard.

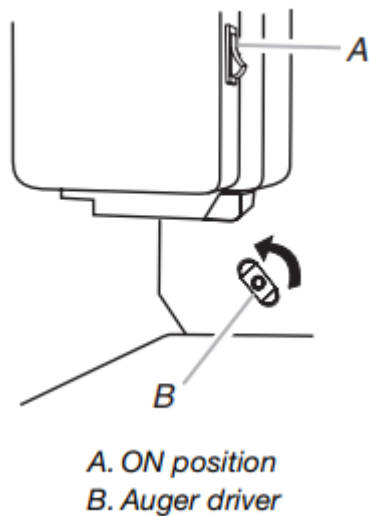

### Ice Production Rate

- Allow 24 hours to produce the first batch of ice. Discard the first three batches of ice produced. Allow 3 days to completely fill the ice storage bin.
- The ice maker should produce approximately 8 to 12 batches of ice in a 24-hour period.
- To increase ice production, lower the freezer and refrigerator temperature. See “Using the Controls.” Wait 24 hours between adjustments.

### Remember

- The quality of your ice will be only as good as the quality of the water supplied to your ice maker. Avoid connecting the ice maker to a softened water supply. Water softener

chemicals (such as salt) can damage parts of the ice maker and lead to poor quality ice. If a softened water supply cannot be avoided, make sure the water softener is operating properly and is well maintained.

- Do not use anything sharp to break up the ice in the bin. This can cause damage to the ice bin and dispenser mechanism.
- Do not store anything on top of the ice maker or in the ice storage bin.

## Water and Ice Dispenser

### IMPORTANT:

- After connecting the refrigerator to a water source, flush the water system. Use a sturdy container to depress and hold the water dispenser pad for 5 seconds, then release it for 5 seconds. Repeat until water begins to flow. Once water begins to flow, continue depressing and releasing the dispenser pad (5 seconds on, 5 seconds off) until a total of 4 gal. (15 L) has been dispensed. This will flush air from the filter and water dispensing system, and prepare the water filter for use. Additional flushing may be required in some households. As air is cleared from the system, water may spurt out of the dispenser.

NOTE: After five minutes of continuous dispensing, the dispenser will stop dispensing water to avoid flooding. To continue dispensing, remove the container and press the dispensing lever again.

- The dispenser will dispense either water or cubed ice.
- Allow 24 hours for the refrigerator to cool down and chill water. Dispense enough water every week to maintain a fresh supply.
- Allow 24 hours to produce the first batch of ice. Discard the first three batches of ice produced.

## Dispense Ice and Water

1. Select water or cubed ice by touching the word “water” or “ice” on the control panel. The light above the control indicates your selection.



2. Press a sturdy container against the dispenser lever.

IMPORTANT: You do not need to apply a lot of pressure to the lever in order to activate the dispenser. Pressing hard will not make the water or ice dispense faster or in greater quantities.

3. Remove the container to stop dispensing.

## Dispenser Light

## NOTES:

- The dispenser lights are LEDs which should not need to be changed
- When you use the dispenser, the lever will automatically turn the light on. If you want the light to be on continuously, you may choose either On or Auto.

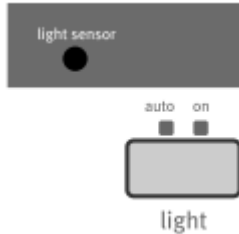

**Auto:** The light sensor monitors the light level in the room. The dispenser light will illuminate at half-power when the light level is low. To activate the Auto option press the “light” button. The Auto indicator light will illuminate.

**On:** For continuous light, press the “light” button a second time. The On indicator light will illuminate.

**Off:** To turn the dispenser light off, press the “light” button a third time

## Dispenser Lock

The dispenser can be locked for easy cleaning or to avoid unintentional dispensing by small children and pets.

**NOTE:** The dispenser lock does not shut off power to the product, to the ice maker, or to the dispenser light. It just deactivates the dispenser lever.

### ***To Lock and Unlock Dispenser:***

Press and hold the “control lock” touch pad for three seconds to lock the dispenser. The indicator light will illuminate when Lock is on.

Press and hold the “control lock” touch pad again for 3 seconds to unlock dispenser. The indicator light will turn off.



## Water Filtration System

The water filter is located in the upper right-hand corner of the refrigerator compartment

### Water Filter Status Lights

The water filter status lights will remind you when it is time to order and replace your water filter. When the yellow (Order) light is on, it is almost time to change the water filter. When the red (Replace) light is on, a new water filter should be installed. The disposable water filter should be replaced at least every 6 months OR earlier if the flow of water to your water dispenser or ice maker decreases noticeably. After replacing the water filter, press and hold Reset Filter or Filter Reset (depending on your model) for 3 seconds. The Order and Replace indicator lights will blink and then go off when the system is reset. See “Using the Controls.”

### **Replacing the Water Filter**

To purchase a replacement water filter, model UKF8001AXX-750 or UKF8001AXX-200, contact your dealer or call 1-800-688-9900 U.S.A. or 1-800-807-6777 Canada.

**IMPORTANT:** Air trapped in the water system may cause water and filter to eject. Always dispense water for at least 2 minutes before removing the filter or blue bypass cap.

1. Turn filter counterclockwise to remove.
2. Remove sealing label from replacement filter and insert the filter end into the filter head.
3. Turn the filter clockwise until it stops. Snap the filter cover closed.
4. Flush the water system. See “Water Dispenser” or “Water and Ice Dispenser.”

**NOTE:** The dispenser feature may be used without a water filter installed. Your water will not be filtered. If this option is chosen, replace the filter with the blue bypass cap.

## **REFRIGERATOR CARE**

### **Cleaning**

Both the refrigerator and freezer sections defrost automatically. However, clean both sections about once a month to avoid buildup of odors. Wipe up spills immediately.

**IMPORTANT:** Because air circulates between both sections, any odors formed in one section will transfer to the other. You must thoroughly clean both sections to eliminate odors. To avoid odor transfer and drying out of food, wrap or cover foods tightly.

### **To Clean Your Refrigerator:**

**NOTE:** Do not use abrasive or harsh cleaners such as window sprays, scouring cleansers, flammable fluids, cleaning waxes, concentrated detergents, bleaches or cleansers containing petroleum products on plastic parts, interior and door liners or gaskets. Do not use paper towels, scouring pads, or other harsh cleaning tools.

1. Unplug refrigerator or disconnect power.
2. Hand wash, rinse, and dry removable parts and interior surfaces thoroughly. Use a clean sponge or soft cloth and a mild detergent in warm water.

3. Wash stainless steel and painted metal exteriors with a clean sponge or soft cloth and a mild detergent in warm water.

- To keep your stainless steel refrigerator looking like new and to remove minor scuffs or marks, it is suggested that you use the manufacturer's approved Stainless Steel Cleaner and Polish, Part Number 20000008. To order the cleaner, call 1-800-688-9900 U.S.A. or 1-800-807-6777 Canada.

**IMPORTANT:** This cleaner is for stainless steel parts only!

Do not allow the Stainless Steel Cleaner and Polish to come into contact with any plastic parts such as the trim pieces, dispenser covers or door gaskets. If unintentional contact does occur, clean plastic part with a sponge and mild detergent in warm water. Dry thoroughly with a soft cloth.

4. There is no need for routine condenser cleaning in normal home operating environments. If the environment is particularly greasy or dusty, or there is significant pet traffic in the home, the condenser should be cleaned every 2 to 3 months to ensure maximum efficiency.

If you need to clean the condenser:

- Remove the base grille.
- Use a vacuum cleaner with a soft brush to clean the grille, the open areas behind the grille and the front surface area of the condenser.
- Replace the base grille when finished.

5. Plug in refrigerator or reconnect power.

## Changing the Light Bulb

**NOTE:** Not all appliance bulbs will fit your refrigerator. Be sure to replace the bulb with an appliance bulb of the same size, shape, and wattage (no greater than 40 watts).

1. Unplug refrigerator or disconnect power.
2. Remove the light shield, if necessary.
  - Top of the refrigerator compartment - Squeeze both sides of the light shield while pulling downward to remove.
  - Beneath ice storage enclosure (on some models) - Press along upper edge of light shield and roll light shield forward to remove.

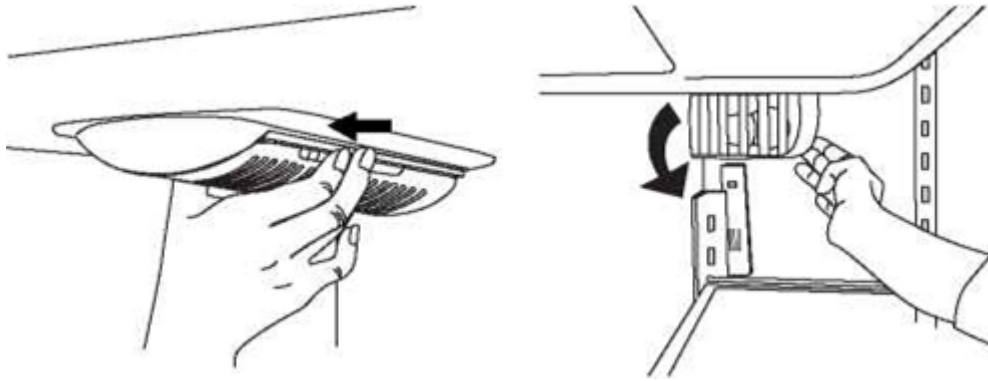

3. Replace burned-out bulb(s) with appliance light bulb(s) no greater than 40 watts.
  4. Replace the light shield(s) by inserting the tabs on the shield into the liner holes and snap into place.
- NOTE: To avoid damaging the light shield, do not force the shield beyond the locking point.
5. Plug in refrigerator or reconnect power.

## TROUBLESHOOTING

### Refrigerator Operation

#### The refrigerator will not operate

- **Power cord unplugged?** Plug into a grounded 3 prong outlet.
- **Is outlet working?** Plug in a lamp to see if the outlet is working.
- **Household fuse blown or circuit breaker tripped?** Replace the fuse or reset the circuit breaker. If the problem continues, call an electrician.
- **Are controls on?** Make sure the refrigerator controls are ON. See “Using the Controls.”
- **New installation?** Allow 24 hours following installation for the refrigerator to cool completely.

NOTE: Adjusting the temperature controls to coldest setting will not cool either compartment more quickly.

#### The motor seems to run too much

Your new refrigerator may run longer than your old one due to its high-efficiency compressor and fans. The unit may run even longer if the room is warm, a large food load is added, doors are opened often, or if the doors have been left open.

#### The refrigerator seems noisy

Refrigerator noise has been reduced over the years. Due to this reduction, you may hear intermittent noises from your new refrigerator that you did not notice from your old model. Below are listed some normal sounds with explanations.

- Buzzing - heard when the water valve opens to fill the ice maker
- Pulsating - fans/compressor adjusting to optimize performance
- Hissing/Rattling - flow of refrigerant, movement of water lines, or from items placed on top of the refrigerator
- Sizzling/Gurgling - water dripping on the heater during defrost cycle
- Popping - contraction/expansion of inside walls, especially during initial cool-down
- Water running - may be heard when ice melts during the
- Defrost cycle and water runs into the drain pan
- Creaking/Cracking - occurs as ice is being ejected from the ice maker mold

#### **The doors will not close completely**

- **Door blocked open?** Move food packages away from door.
- **Bin or shelf in the way?** Push bin or shelf back into the correct position.

#### **The doors are difficult to open**

- **Gaskets dirty or sticky?** Clean gaskets and contact surfaces with mild soap and warm water. Rinse and dry with soft cloth.

### **Temperature and Moisture**

#### **Temperature is too warm**

- **New installation?** Allow 24 hours following installation for the refrigerator to cool completely.
- **Door(s) opened often or left open?** Allows warm air to enter refrigerator. Minimize door openings and keep doors fully closed.
- **Large load of food added?** Allow several hours for refrigerator to return to normal temperature.
- **Controls set correctly for the surrounding conditions?** Adjust the controls a setting colder. Check temperature in 24 hours. See “Using the Controls.”

#### **Temperature is too cold in refrigerator**

- **Refrigerator air vent blocked?** If the air vent located in the top, left, rear corner of the refrigerator compartment is blocked by items placed directly in front of it, the refrigerator will get too cold. Move items away from the air vent.
- **Ice storage bin in correct position?** See “Ice Maker and Ice Storage Bin.”

- **Controls set correctly for the surrounding conditions?** Adjust the controls a setting warmer. Check temperature in 24 hours. See “Using the Controls.”

### **There is interior moisture buildup**

NOTE: Some moisture buildup is normal.

- **Humid room?** Contributes to moisture buildup.
- **Door(s) opened often or left open?** Allows humid air to enter refrigerator. Minimize door openings and keep doors fully closed

## **Ice and Water**

### **The ice maker is not producing ice or not enough ice**

- **Refrigerator connected to a water supply and the supply shut-off valve turned on?** Connect refrigerator to water supply and turn water shut-off valve fully open.
- **Kink in the water source line?** A kink in the line can reduce water flow. Straighten the water source line.
- **Ice maker turned on?** Make sure ice maker is ON. See “Ice Maker and Ice Storage Bin.”
- **New installation?** Wait 24 hours after ice maker installation for ice production to begin. Wait 72 hours for full ice production.
- **Refrigerator door closed completely?** Close the door firmly. If it does not close completely, see “The doors will not close completely.”
- **Large amount of ice recently removed?** Allow 24 hours for ice maker to produce more ice.
- **Ice cube jammed in the ice maker ejector arm?** Remove ice from the ejector arm with a plastic utensil.
- **Water filter installed on the refrigerator?** Remove filter and operate ice maker. If ice volume improves, then the filter may be clogged or incorrectly installed. Replace filter or reinstall it correctly.
- **Reverse osmosis water filtration system connected to your cold water supply?** This can decrease water pressure. See “Water Supply Requirements.”

### **The ice cubes are hollow or small**

NOTE: This is an indication of low water pressure.

- **Water shut-off valve not fully open?** Turn the water shut-off valve fully open.
- **Kink in the water source line?** A kink in the line can reduce water flow. Straighten the water source line.

- **Water filter installed on the refrigerator?** Remove filter and operate ice maker. If ice quality improves, then the filter may be clogged or incorrectly installed. Replace filter or reinstall it correctly.
- **Reverse osmosis water filtration system connected to your cold water supply?** This can decrease water pressure. See “Water Supply Requirements.”
- **Questions remain regarding water pressure?** Call a licensed, qualified plumber.

#### Off-taste, odor, or gray color in the ice

- **New plumbing connections?** New plumbing connections can cause discolored or off-flavored ice.
- **Ice stored too long?** Discard ice. Wash ice bin. Allow 24 hours for ice maker to make new ice.
- **Odor transfer from food?** Use airtight, moisture proof packaging to store food.
- **Are there minerals (such as sulfur) in the water?** A water filter may need to be installed to remove the minerals.
- **Water filter installed on the refrigerator?** Gray or dark discoloration in ice indicates that the water filtration system needs additional flushing. Flush the water system before using a new water filter. Replace water filter when indicated. See “Water Filtration System.”

#### The water and ice dispenser will not operate properly

- **Refrigerator connected to a water supply and the supply shut-off valve turned on?** Connect refrigerator to water supply and turn water shut-off valve fully open.
- **Kink in the water source line?** Straighten the water source line.
- **New installation?** Flush and fill the water system. See “Water and Ice Dispensers.”
- **Is the water pressure at least 35 psi (241 kPa)?** The water pressure to the home determines the flow from the dispenser. See “Water Supply Requirements.”
- **Water filter installed on the refrigerator?** Remove filter and operate dispenser. If water flow increases, the filter may be clogged or incorrectly installed. Replace filter or reinstall it correctly.
- **Water dispenser measured fill feature is not dispensing an accurate amount of water?** Calibrate the water dispenser. See “Water and Ice Dispensers.”
- **Refrigerator door closed completely?** Close the door firmly. If it does not close completely, see “The doors will not close completely.”
- **Recently removed the doors?** Make sure the water dispenser wire/tube assembly has been properly reconnected at the top of the refrigerator door. See “Refrigerator Doors and Drawer.”

- **Reverse osmosis water filtration system connected to your cold water supply?**

This can decrease water pressure. See “Water Supply Requirements.”

### **Water is leaking from the dispenser system**

NOTE: One or two drops of water after dispensing is normal.

- **Glass not being held under the dispenser long enough?** Hold the glass under the dispenser 2 to 3 seconds after releasing the dispenser lever.
- **New installation?** Flush the water system. See “Water and Ice Dispensers.”
- **Recently changed water filter?** Flush the water system. See “Water and Ice Dispensers.”

### **Water from the dispenser is warm**

NOTE: Water from the dispenser is only chilled to 50°F (10°C).

- **New installation?** Allow 24 hours after installation for the water supply to cool completely.
- **Recently dispensed large amount of water?** Allow 24 hours for water supply to cool completely.
- **Water not been recently dispensed?** The first glass of water may not be cool. Discard the first glass of water.
- **Refrigerator connected to a cold water pipe?** Make sure the refrigerator is connected to a cold water pipe. See “Water Supply Requirements.”

#### **Warning**

This content is compiled from multiple sources and is provided for reference purposes only. It may not be complete or fully applicable to all situations. If you are unable to resolve your issue, please contact the product manufacturer or an authorized service provider for official support.