

User Manual

FEATURES AT A GLANCE

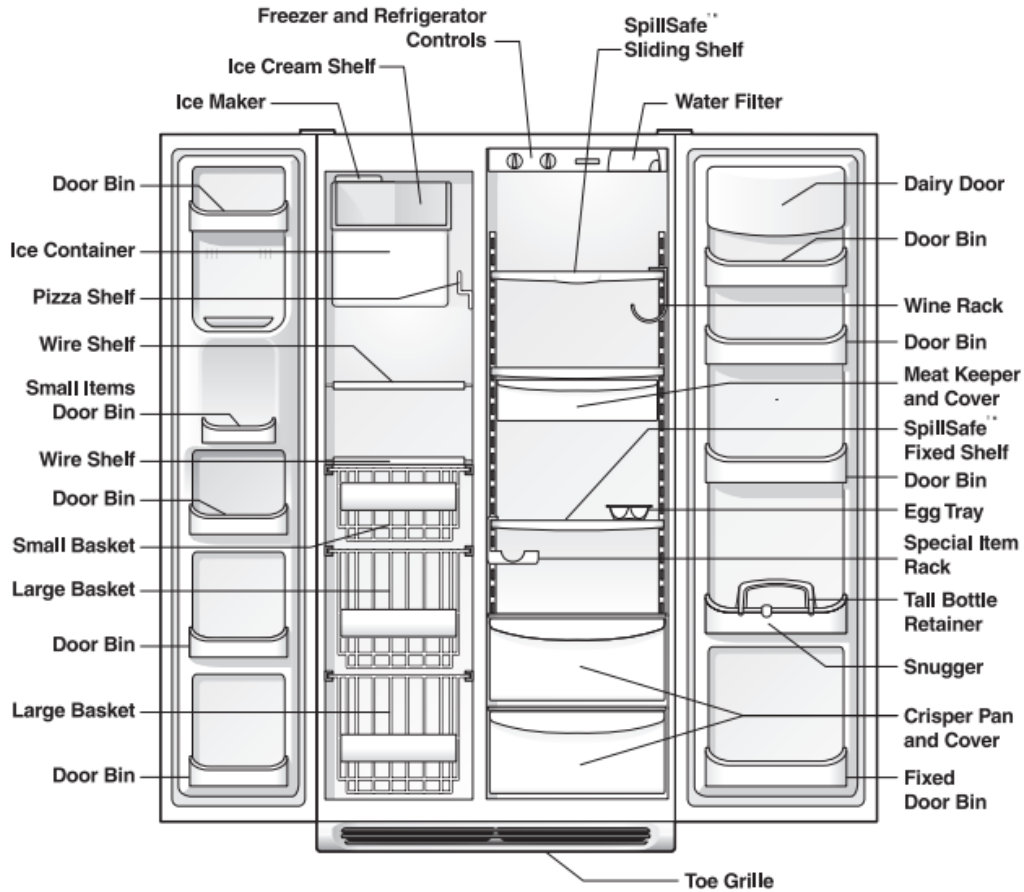

TEMPERATURE CONTROLS

COOL DOWN PERIOD

To ensure safe food storage, allow the refrigerator to operate with the doors closed for at least 8 to 12 hours before loading it with food.

TEMPERATURE ADJUSTMENT

- After 24 hours, adjust the controls as needed. Adjust temperatures gradually; move the knob in small increments, allowing the temperature to stabilize.
- For colder temperatures, turn the knob towards Colder.
- For warmer temperatures, turn the knob towards Cold. To maintain temperatures, a fan circulates air in the refrigerator and freezer compartments. For good circulation, do not block cold air vents with food items.

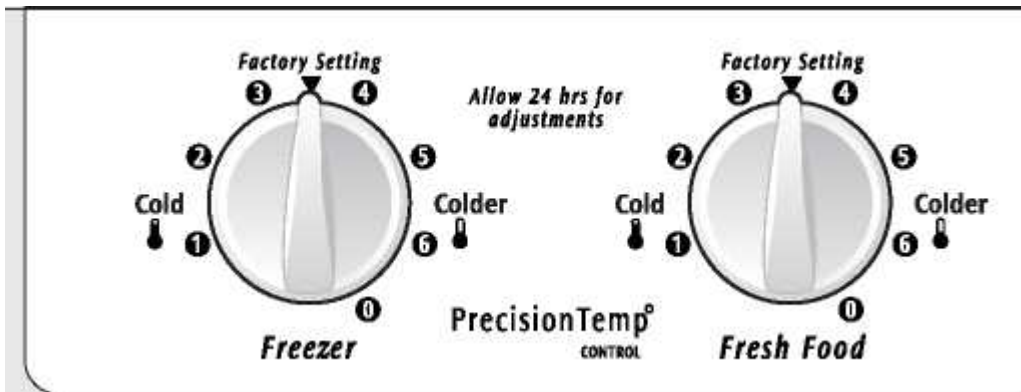

Refrigerator & Freezer Controls (Features may vary according to model.)

IMPORTANT

Turning the Freezer and Fresh Food Controls to “0” turns off the compressor and prevents your refrigerator from cooling, but does not disconnect the power to the light bulb and other electrical components. To turn off power to your refrigerator you must unplug the power cord from the wall outlet.

TEMPERATURE ADJUSTMENT GUIDE	
If Fresh Food Compartment Is Too Warm	Turn Fresh Food Control Slightly Towards Colder .
If Fresh Food Compartment Is Too Cold	Turn Fresh Food Control Slightly Towards Cold .
If Freezer Compartment Is Too Warm	Turn Freezer Control Slightly Towards Colder .
If Freezer Compartment Is Too Cold	Turn Freezer Control Slightly Towards Cold .
* To Turn Refrigerator Off	Turn Freezer and Fresh Food Controls To 0 .

LOOKING INSIDE

PIZZA SHELF (SOME MODELS)

This shelf is attached to the freezer wall beside the ice dispenser container. This convenient area allows for storage of pizza and other tall items placed vertically between the ice dispenser container and the freezer wall.





Pizza Shelf

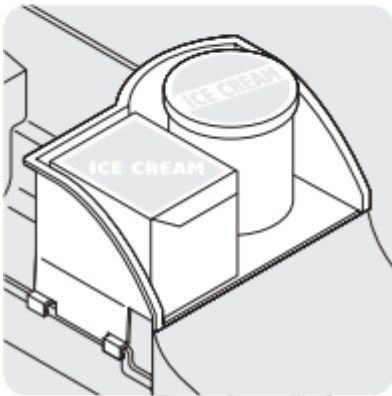

Ice Cream Shelf

ICE CREAM SHELF (SOME MODELS)

This shelf attaches to the top of the ice dispenser container. It allows storage of both round and rectangular cartons of your favorite ice cream.

TIP-UP SHELF (SOME MODELS)

A Tip-Up shelf in the freezer section allows tall items to be easily stored.

ADJUSTABLE DOOR BINS

Some models have adjustable door bins that can be moved to suit individual needs.

To move door bins

1. Lift bin straight up.
2. Remove bin.
3. Place bin in desired position.
4. Lower bin onto supports until locked in place.

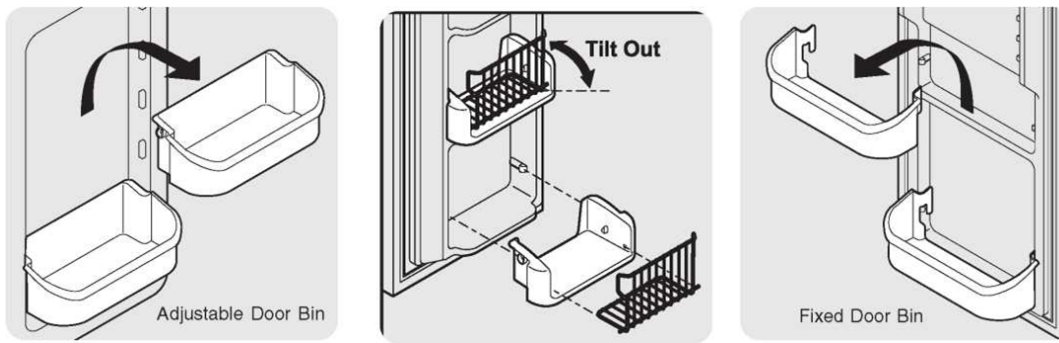

CANTILEVER SHELF ADJUSTMENT

Refrigerator shelves are easily adjusted to suit individual needs. Before adjusting the shelves, remove all food.

Cantilever shelves are supported at the back of the refrigerator.

To adjust cantilever shelves:

1. Lift front edge up.
2. Pull shelf out.

Replace the shelf by inserting the hooks at rear of the shelf into the wall bracket. Lower the shelf into the desired slots and lock into position.

* SpillSafe™ glass shelves (some models) catch and hold accidental spills. In some models, the * SpillSafe™ shelves slide out for easy access to food and for fast cleaning. The shelves slide out independently of their mounting brackets. Just pull the front of the shelf forward. Shelves can be extended as far as the stopper will allow but are not removable from their mounting brackets.

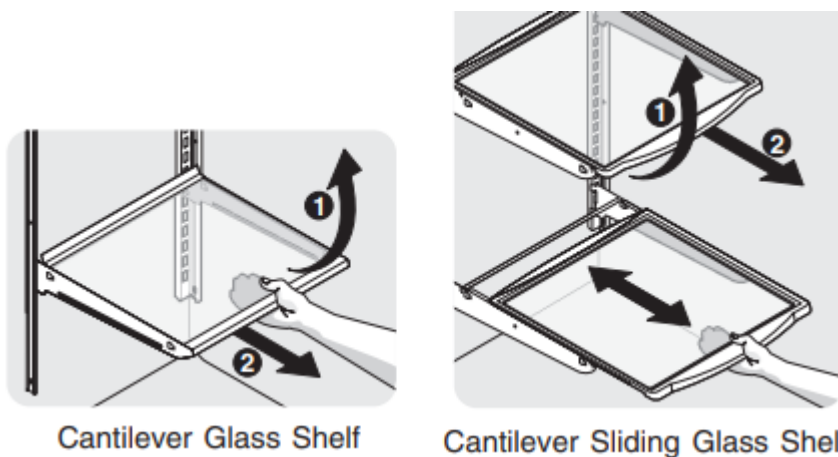

Cantilever Glass Shelf

Cantilever Sliding Glass Shelf

DOOR STORAGE

Door bins and shelves are provided for convenient storage of jars, bottles, and cans. Frequently used items can be quickly selected.

Some models have door bins that can accommodate gallonsized plastic drink containers and economy-sized jars and containers. Some bins are adjustable for maximum storage capacity.

The dairy compartment, which is warmer than the general food storage section, is intended for short term storage of cheese, spreads, or butter.

TALL BOTTLE RETAINER (SOME MODELS)

The Tall Bottle Retainer keeps tall containers in the bin from falling forward when opening or closing the refrigerator door. To install, hold the retainer at the top, and slide it over the outside wall of the bin, as shown in the diagram. The Tall Bottle Retainer works best with a Bin Snugger.

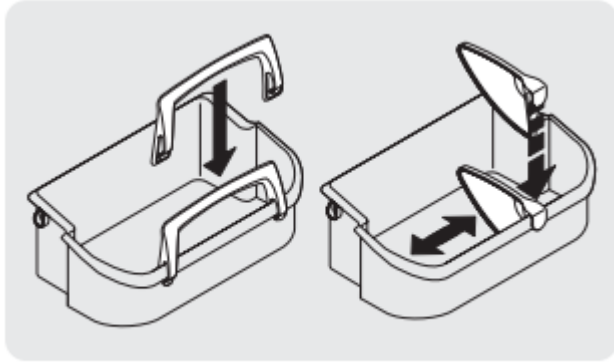

Tall Bottle Retainer (left) and Bin Snugger (right)

SPECIAL ITEM RACK

(SOME MODELS)

The innovative design of the Special Item Rack allows you to store a six-pack of 12 ounce drink cans, a bottle of wine, a two-liter soft drink bottle, or a carton of eggs. The Special Item Rack mounts on the left side of your refrigerator. To install, just slide the Special Item Rack onto any shelf as shown in the drawing.

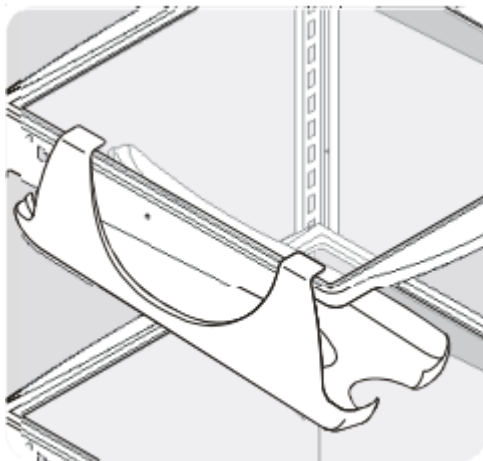

Special Item Rack

LOOKING INSIDE - SPECIAL STORAGE AREAS

CRISPERS (SOME MODELS)

The crispers, located under the bottom refrigerator shelf, are designed for storing fruits, vegetables, and other fresh produce. Wash items in clear water and remove excess water before placing them in the crispers. Items with strong odors or high moisture content should be wrapped before storing.

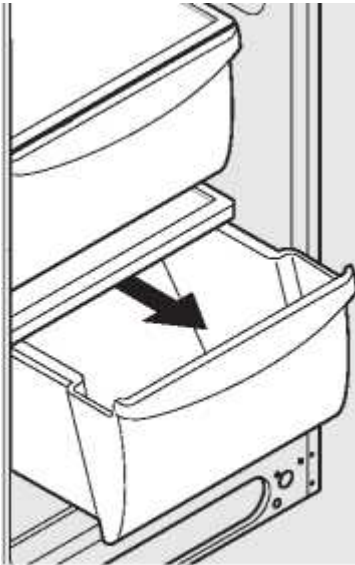

Crisper Drawer

HUMIDITY CONTROL (SOME MODELS)

The Humidity Control, present on some models with crisper drawers, allows you to adjust the humidity within the crisper. This can extend the life of fresh vegetables that keep best in high humidity.

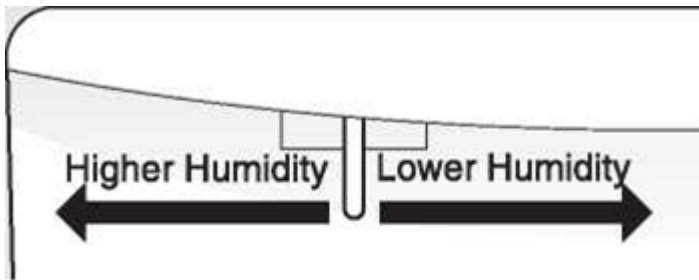

Crisper Humidity Control

DELI DRAWER (SOME MODELS)

Some models are equipped with a Deli Drawer for storage of luncheon meats, spreads, cheeses, and other deli items.

MEAT KEEPER (SOME MODELS)

Some models are equipped with a Meat Keeper. Meat Keeper temperatures can be adjusted by sliding the Meat Keeper Temperature Control in either direction. Use this pan for short term storage of bulk meat items. If meats are to be kept longer than one or two days, they should be frozen. The

Meat Keeper is fixed and cannot be moved up or down. If fruits or vegetables are to be stored in the Meat Keeper, set the Meat Keeper Temperature Control to a warmer setting to prevent freezing.

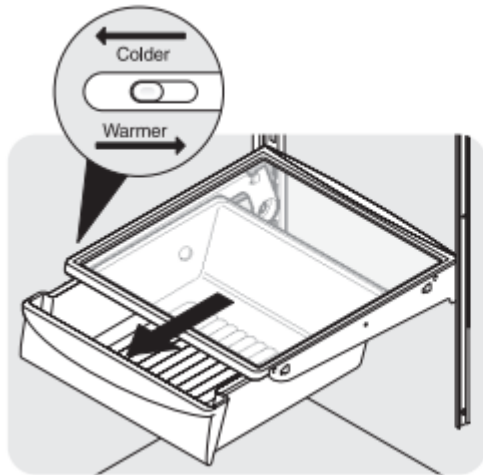

Meat Keeper with Temperature Control

WINE RACK (SOME MODELS)

The wine rack stores bottles of wine, or single two-liter plastic bottles of juice or soda pop. To install, slide the Wine Rack onto the shelf with the curve facing in. To remove, slide the Wine Rack out. Install on either side of shelf.

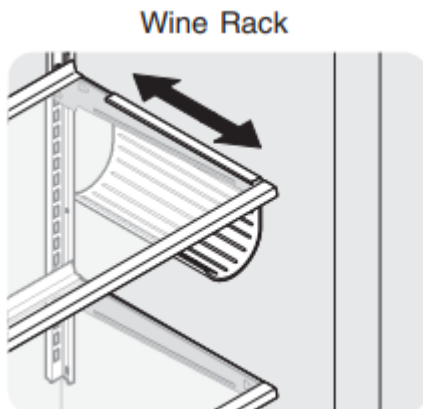

AUTOMATIC ICE AND WATER DISPENSER

AUTOMATIC ICE & WATER DISPENSER OPERATING INSTRUCTIONS

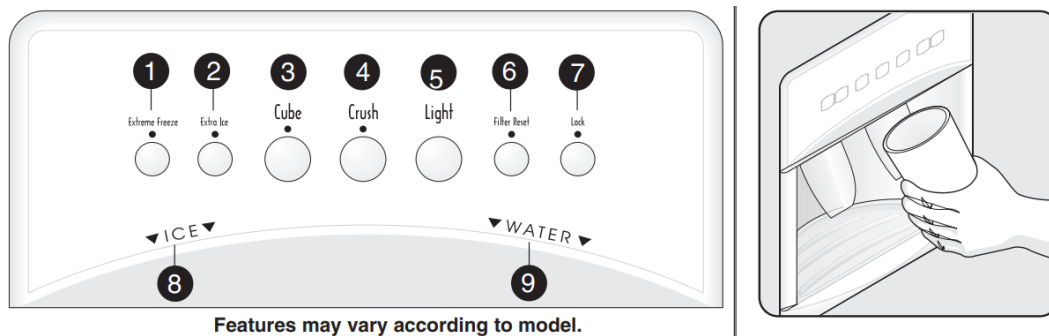

<p>EXTREME FREEZE</p>	<p>To freeze food at a faster rate to preserve freshness, push the Touch Pad 1 for 3-5 seconds to activate this feature. A green light will appear above the Touch Pad. Push the Touch Pad 1 again for 3-5 seconds to deactivate.</p>
<p>EXTRA ICE</p>	<p>To increase ice production for special occasions, such as parties, push the Touch Pad 2 for 3-5 seconds to activate this feature. A green light will appear above the Touch Pad. Push the Touch Pad 2 again for 3-5 seconds to deactivate.</p>
<p>CUBE</p>	<p>Press the CUBE Touch Pad 3 to get cubed ice. A green light will appear above the Touch Pad. Press glass against ICE dispensing paddle 8 as far up as possible to catch all ice.</p>
<p>CRUSH</p>	<p>Press the CRUSH Touch Pad 4 to get crushed ice. A green light will appear above the Touch Pad.</p>
<p>LIGHT</p>	<p>Press glass against ICE dispensing paddle 8 as far up as possible to catch all ice.</p> <p>Press the LIGHT Touch Pad 5 to turn on dispenser light. Press 5 again to turn the light off.</p> <p>The light also turns on automatically when ice and/or water is dispensed. Replace light bulb with an appliance bulb of the same wattage.</p>
<p>FILTER STATUS</p>	<p>The FILTER STATUS indicator light above the Touch Pad 6 will light up each time the dispenser is used. The following filter light indications are:</p> <p>Green The filter is still operating within its specified life cycle.</p> <p>Amber The filter has reached approximately 80% of its useful life. This is the recommended time to purchase a replacement filter.</p> <p>Red The filter is 100% used up. Change the filter as soon as possible.</p> <p>After the filter cartridge has been changed, press and hold the FILTER RESET Touch Pad 6 for 10-15 seconds.</p> <p>NOTE: The Green, Red and Amber lights will flash when reset is completed.</p>
<p>LOCK</p>	<p>The Ice & Water Dispenser can be locked out to prevent unwanted use.</p>



	<p>To Lock Out Press the LOCK Touch Pad 7 for 3-5 seconds. A Red light will appear above the Touch Pad.</p> <p>To Unlock Press the LOCK Touch Pad 7 for 3-5 seconds until the Red light above the Touch Pad goes out.</p>
WATER	<p>To operate the water dispenser, press a glass against the WATER dispensing paddle 9 . To stop dispensing water, pull the glass away from the dispensing paddle 9 . Dispensed water is not cold. For colder water, add crushed ice or cubes before dispensing water. A drip tray located at the base of the dispenser catches small spills and allows them to evaporate. This drip tray is removable and dishwasher safe. Do not pour water and excess ice in this area because there is no drain.</p>



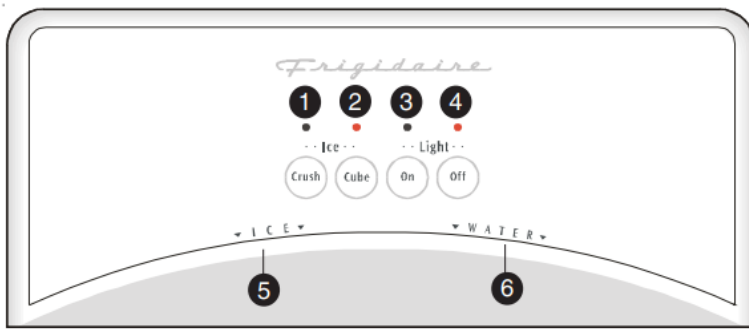

Features may vary according to model.



Crushed	Press the Crushed Touch Pad 1 to get crushed ice. A red indicator will appear above the Touch Pad. Press glass against ICE dispensing paddle 5 as far up as possible to catch all ice.
Cubed	Press the Cubed Touch Pad 2 to get cubed ice. A red indicator will appear above the Touch Pad. Press glass against ICE dispensing paddle 5 as far up as possible to catch all ice.
Light On	Press the Light On Touch Pad 3 to turn on dispenser light. A red indicator will appear above the Touch Pad.
Light Off	Press the Light Off Touch Pad 4 to turn off dispenser light. A red indicator will appear above the Touch Pad.
WATER	To operate the water dispenser , press a glass against the WATER dispensing paddle 6 . Dispensed water is released into the glass. To stop dispensing water, pull the glass away from the dispensing paddle 6 . Dispensed water is released into the glass. For colder water, add crushed ice or cubes before dispensing water. A drip tray located at the bottom of the dispenser catches small spills and allows them to evaporate. This drip tray is removable and dishwasher safe. Do not pour water and excess ice in this area because there is no drain.

AUTOMATIC ICE AND WATER DISPENSER

HOW THE WATER DISPENSER WORKS

The water tank, located behind the drawers in the refrigerator compartment, automatically fills as water is dispensed. For proper dispenser operation, the recommended supply water pressure should fall between 30 psi and 100 psi.

After the refrigerator is connected to the water supply, fill the water tank by drawing one glass of water. It may take about 1% minutes after activating the dispenser paddle before water begins to fill this first glass. Continue flushing the system for 3 minutes to rid the tank and plumbing connections of any impurities. The water dispenser has a built in shutoff device that will stop the

water flow after 3 minutes of continuous use. Simply release the dispenser paddle to reset the shutoff mechanism.

HOW THE ICE DISPENSER WORKS -SIDE MOUNTED

The ice maker and container are located in the top of the freezer compartment. After the refrigerator is installed properly and has cooled for several hours, the ice maker can begin making ice within 24 hours. Air in new plumbing lines may cause the ice maker to cycle two or three times before making a full tray of ice. To begin ice production, lower the wire signal arm to the "down" or ON position. With no usage it will take approximately 2 days to fill the ice container.

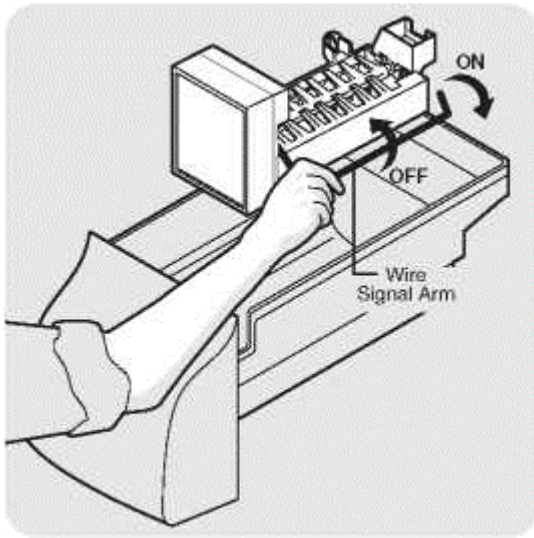

The ice maker turns off automatically when the ice container becomes full. To stop the ice maker, lift the wire signal arm until it clicks, and locks in the "up" or OFF position.

HOW THE ICE DISPENSER WORKS -REAR MOUNTED

The ice maker and container are located in the top of the freezer compartment. After the refrigerator is installed properly and has cooled for several hours, the ice maker can begin making ice within 24 hours. Air in new plumbing lines may cause the ice maker to cycle two or three times before making a full tray of ice.



Ice production is controlled by the ice maker's On/Off power switch. Press the switch to the "O" position to turn it Off and press it to the "I" position to turn it On. With no usage it will take approximately 2 days to fill the ice container. The ice maker also has a built-in wire signal arm, which automatically stops ice production when the ice bin is full. This signal arm should not be used to manually stop the ice maker.

The ice maker produces 4 to 6 pounds of ice every 24 hours depending on usage conditions. Ice is produced at a rate of 8 cubes every 75 to 90 minutes.

Because of new plumbing connections, the first production of ice cubes may be discolored or have an odd flavor. These should be discarded until the cubes made are free of discoloration and taste.

ICE AND WATER DISPENSER FEATURES

The ice and water dispenser conveniently dispenses chilled water, and ice cubes or crushed ice, depending on the model.

To operate the ice dispenser, select the ice option desired using the touchpad. Press a glass against the dispensing paddle as far up as possible to catch all ice. To stop dispensing ice, pull glass away from dispensing paddle. Do not remove the glass until the ice has completely dispensed. (Complete instructions for the dispenser operation are attached to the inside of the freezer door.)

ICE DISPENSER TIPS

- Ice cubes stored too long may develop an odd flavor. Empty the ice container and ensure that the wire signal arm is in its "down" or ON position (side mounted) or the ice maker's On/Off power switch is turned On-set to the "I" position (rear mounted). The ice maker will then produce more ice.
- Occasionally shake the ice container to keep ice separated.

- Keep the wire signal arm in its “up” or OFF position (side mounted) or the ice maker's On/Off power switch turned Off-set to the “O” position (rear mounted) until the refrigerator is connected to the water supply or whenever the water supply is turned off.

CAUTION

If the dispensing paddle is pushed for more than 4 minutes, the dispenser motor may overload and stop. The overload protector will reset automatically after 3 or 4 minutes.

- If a large quantity of ice is needed at one time, it is best to remove cubes directly from the ice container.
- The following sounds are normal when the ice maker is operating:
 - Motor running
 - Ice dropping into ice container
 - Water valve opening or closing
 - Ice loosening from tray
- Running water
- Stop the ice maker when cleaning the freezer and during vacations.
- If the ice maker will be turned off for a long period of time, turn the water supply valve to the closed position.

CLEANING THE ICE DISPENSER

Clean the dispenser and ice container at regular intervals, particularly before you take a vacation or move, or if the ice dispenser sticks.

1. Stop ice production by lifting the wire signal arm to the "up" or OFF position (side mounted) or the ice maker's On/ Off power switch turned Off-set to the “O” position (rear mounted) .
2. Remove ice container by lifting up and out. Empty and carefully clean the container with mild detergent. Rinse with clear water. Do not use harsh or abrasive cleaners. Allow ice container to dry completely before replacing in the freezer.
3. Remove ice chips and clean the shelf and chute that supports the ice container.
4. Replace the ice container. Lower the wire signal arm on the ice maker to the "down" or ON position (side mounted) or the ice maker's On/Off power switch is turned On-set to the “I” position. (rear mounted)and the ice maker will resume production.

WARNING

Do not use the ice chute as a handle when removing or replacing the ice storage bin. Surfaces there may be sharp.

Do not put fingers up ice chute. Surfaces there may be sharp.

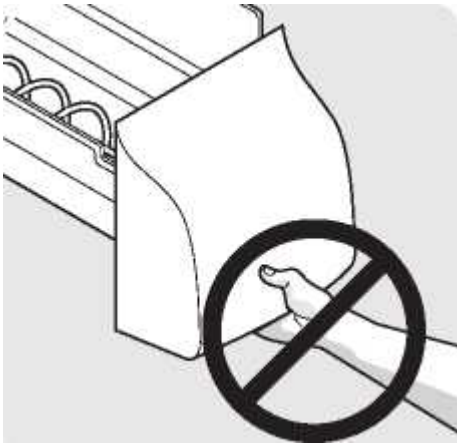

Remove and empty the ice storage bin if:

1. An extended power failure (one hour or longer) causes ice cubes in the ice storage bin to melt and freeze together and jam the dispenser mechanism.
2. The ice dispenser is not used frequently. Ice cubes will freeze together in the bin and jam the dispenser mechanism. Remove the ice storage bin and shake to loosen the cubes.

CAUTION

NEVER use an ice pick or similar sharp instrument to break up the ice. This could damage the ice storage bin and dispenser mechanism.

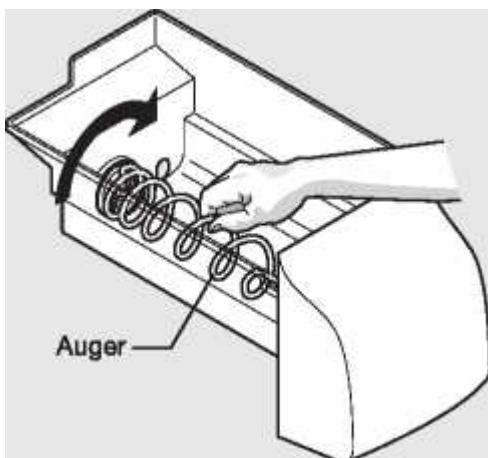

PURESOURCE™ * ICE AND WATER FILTER (SOME MODELS)

System Startup:

Water supply does not need to be turned off, however, do not use ice and water dispenser while installing filter. The filter cartridge has already been installed in the filter housing at the factory. Refer to the *How The Water Dispenser Works* section to properly fill the system with water.

NOTE If you purchased a refrigerator with a PureSource™ * Ice and Water filter, please read the following use and care information. This ice and water filter system filters water to your ice maker and water dispenser. It is located in the upper right back corner of the fresh food compartment.

Order new filter cartridges through the dealer where you bought the refrigerator, contact the Consumer Assistance Center at 1- 800-944-9044, or go to our web site at www.frigidaire.com. It might be good to order some filter cartridges when you first install your refrigerator. Be sure to ask for the RG-100 PureSource™* replacement cartridge

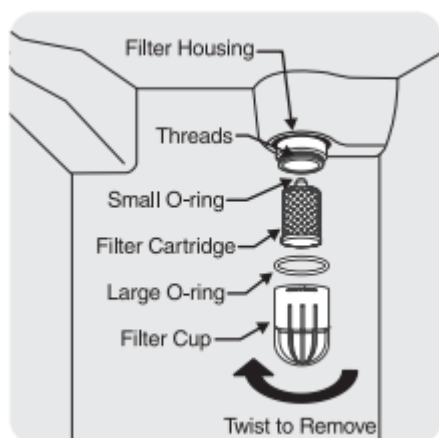

Changing the Filter:

Water conditions vary throughout the world, but changing the water filter every 6 - 9 months normally will ensure the highest possible water quality. The Filter Status light will turn red after 400 gallons of water has flowed through the ice and water dispenser (some models). Also, if the filter has been in a refrigerator that has not been in use for awhile (during moving for example), change the filter before reinstalling the refrigerator.

The dispenser system will also operate without filtration (with filter cartridge removed).

To change filter:

It is not necessary to turn the water supply off to change the filter.

1. Open freezer door and leave open until filter change is complete.
2. Set ice maker wire signal arm to the OFF (up) position (side mounted) or the ice maker's On/Off power switch turned Off-set to the "O" position (rear mounted) .
3. Hold filter cup firmly, and unscrew towards left (Some water could leak out as you remove cup. This is normal.). Filter cartridge should come down with cup. If cartridge remains in housing, pull down gently, while twisting filter back and forth.
4. Rinse out cup under running water.
5. The large o-ring that seals the filter system sets in the o-ring groove down inside the cup. Should the o-ring fall out during filter cartridge replacement, simply place it back in the groove prior to screwing the cup back in place. If the o-ring becomes damaged, you will need to order one from the *Consumer Assistance Center*.
6. Discard old filter cartridge.

7. Remove new filter cartridge from packaging. Place in cup. The end with the small o-ring should be up, out of the cup.
8. Screw cup, with filter, back onto housing. Do Not Use Wrench To Reinstall Cup. Filter cartridge will self-align as cup is tightened. Be sure cup is completely tightened with *PureSource™* logo facing outward. Do Not Tighten Past Stop.
9. Set ice maker wire signal arm to the ON (down) position (side mounted) or the ice maker's On/Off power switch is turned On-set to the "I" position. (rear mounted).
10. Check for leaks. Open refrigerator door. Wipe any water droplets from the filter cup. Fill a glass with water. If there is a leak, unscrew filter cup, and reinsert the filter cartridge. Check placement of large O-ring. Reinstall filter cup, making certain it is tightened completely.
11. To condition filter system and purge air from water line, fill a glass with water. Continue flushing the system for approximately 3 minutes to assure that the purest water possible is stored in the water tank.

PURESOURCE2™ * ICE AND WATER FRONT FILTER (SOME MODELS)

System Startup:

Water supply does not need to be turned off, however, do not use ice and water dispenser while installing filter.

The filter cartridge has already been installed in the filter housing at the factory. Refer to the How The Water Dispenser Works section to properly fill the system with water.

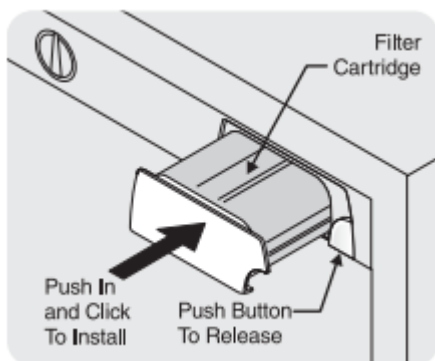

Changing the Filter:

Water conditions vary throughout the world, but changing the water filter every 6 - 9 months normally will ensure the highest possible water quality. The Filter Status light will turn red after approximately 400 gallons of water has flowed through the ice and water dispenser. Also, if the filter has been in a refrigerator that has not been in use for awhile (during moving for example), change the filter before reinstalling the refrigerator. The dispenser system will also operate without filtration (with filter cartridge removed and bypass installed).

To change filter:

It is not necessary to turn the water supply off to change the filter.

1. Set ice maker wire signal arm to the OFF (up) position (side mounted) or the ice maker's On/Off power switch turned Off-set to the "O" position (rear mounted) .
2. Push the *Filter Release Button*, located to the right of the filter cartridge, to release the filter from the housing. To minimize the possibility of the filter falling out of the housing during removal, it would be best to hold the filter as it moves out toward you.

NOTE

A small amount of water may be released during this operation. You should have a paper towel or dish cloth handy to wipe up any water that may drip out of the filter or housing. Two small holes near the back of the housing have been added for any excess water to escape. It would be best to clear away any food near this area on the top shelf in advance of removing the filter.

3. Pull the old filter cartridge straight out of the housing.
4. Discard the old filter.
5. Remove the new filter cartridge from the packaging and insert into the filter housing the same way the old one came out.
6. When the cartridge is almost in, you will feel it stop against the clip assembly in the back of the housing. The clip assembly holds the filter cartridge firmly in place. At this point, you will need to push firmly until the cartridge snaps fully in place. When completely in place, the front of the filter cartridge will be flush with the front of the housing.
7. Set ice maker wire signal arm to the ON (down) position (side mounted) or the ice maker's On/Off power switch is turned Onset to the "I" position. (rear mounted).
8. Fill a glass with water. As you are doing this, check for leaks at the filter housing. There will be noticeable spurts and sputters as the system pushes the air out through the system and out the dispenser nozzle. This is normal.
9. After you have run one glass of water, continue to flush the system for approximately 3 minutes to assure that the purest water possible is stored in the water storage tank.

NORMAL OPERATING SOUNDS & SIGHTS

UNDERSTANDING THE SOUNDS YOU MAY HEAR

Your new high-efficiency refrigerator may make unfamiliar sounds. These are all normal sounds and soon will become familiar to you. They also indicate your refrigerator is operating as designed. Hard surfaces, such as vinyl or wood floors, walls, and kitchen cabinets may make sounds more noticeable. Listed below are descriptions of some of the most common sounds you may hear, and what is causing them.

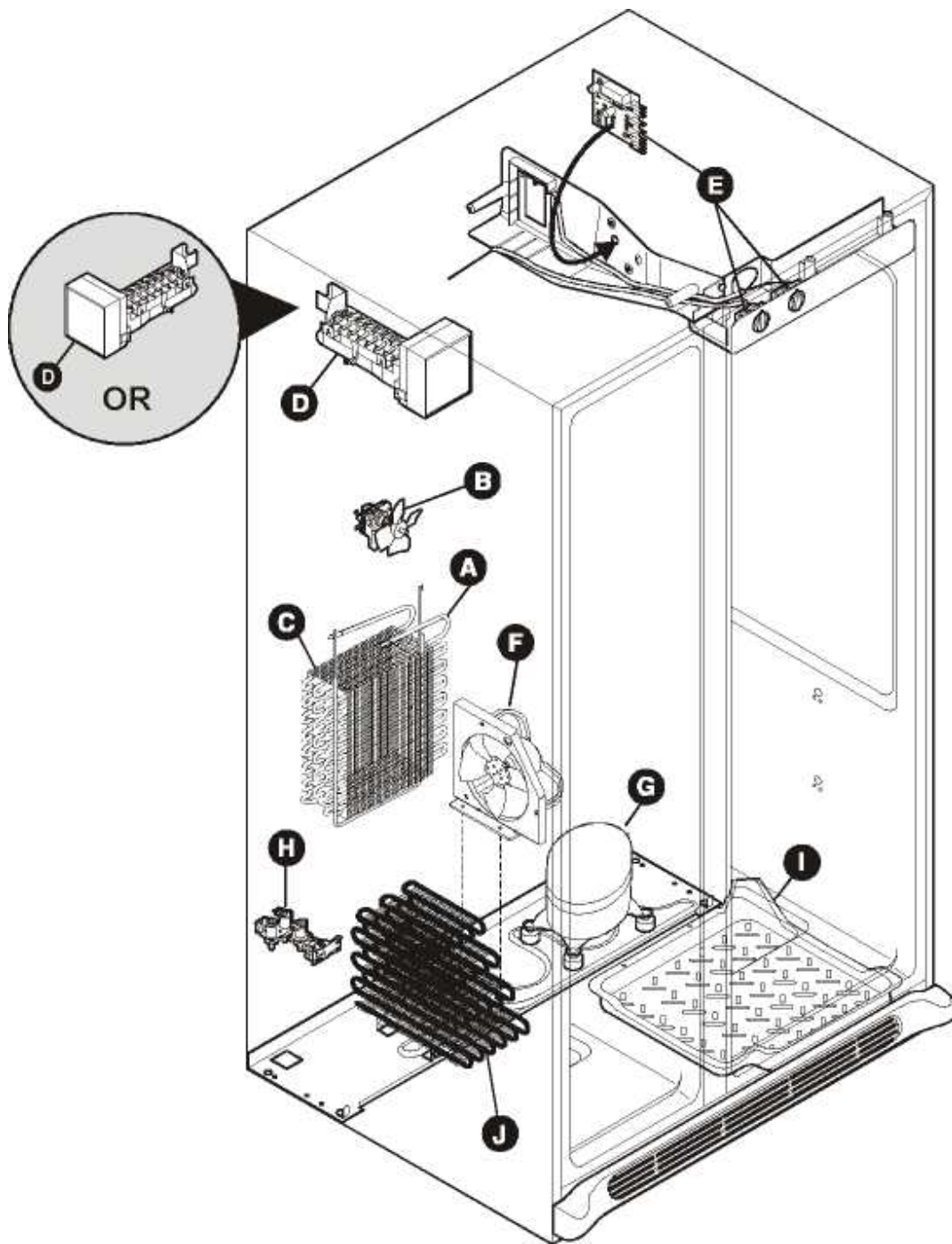

A. Evaporator

The flow of refrigerant through the evaporator may create a boiling or gurgling sound.

B. Evaporator Fan

You may hear air being forced through the refrigerator by the evaporator fan.

C. Defrost Heater

During defrost cycles, water dripping onto the defrost heater may cause a hissing or sizzling sound. After defrosting, a popping sound may occur.

IMPORTANT



During the automatic defrost cycle, you may notice a red glow in the vents on the back wall of your freezer compartment. This is normal during the defrost cycle.

D. Automatic Ice Maker

If your refrigerator is equipped with an automatic ice maker, you will hear ice cubes falling into the ice bin.

E. Cold Control & Automatic Defrost Control

These parts can produce a snapping or clicking sound when turning the refrigerator on and off.

F. Condenser Fan

You may hear air being forced through the condenser by the condenser fan.

G. Compressor

Modern, high-efficiency compressors operate much faster than older models. The compressor may have a high-pitched hum or pulsating sound.

H. Water Valve

If your refrigerator is equipped with an automatic ice maker, you will hear a buzzing sound as the water valve opens to fill the ice maker during each cycle.

IMPORTANT

Your ice maker is shipped with the wire signal arm in the ON position. To ensure proper function of your ice maker, hook up water supply immediately or turn ice maker OFF by lifting the wire signal arm until it clicks or locks in the UP position.

I. Drain Pan (not removable)

You may hear water running into the drain pan during the defrost cycle.

J. Condenser

May create minimal sounds from forced air.

CARE & CLEANING

Keep your refrigerator and freezer clean to prevent odor build-up. Wipe up any spills immediately and clean both sections at least twice a year. Never use metallic scouring pads, brushes, abrasive cleaners or strong alkaline solutions on any surface. Do not wash any removable parts in a dishwasher. Always unplug the electrical power cord from the wall outlet before cleaning.

NOTE

- Turning the freezer and fresh food controls to “O” turns off the compressor, but does not disconnect electrical power to the light bulb or other electrical components. To turn off power to your refrigerator, you must unplug the power cord from the wall outlet.

- Do not use razor blades or other sharp instruments which can scratch the appliance surface when removing adhesive labels. Any glue left from tape or labels can be removed with a mixture of warm water and mild detergent, or, touch the glue residue with the sticky side of tape you have already removed. Do not remove the serial plate.



Care & Cleaning Chart

Part	Cleaning Agents	Tips and Precautions
Interior/Door Liner	<ul style="list-style-type: none"> • Soap and water • Baking soda and water 	Use 2 tablespoons of baking soda in 1 quart of warm water. Be sure to wring excess water out of sponge or cloth before use. Avoid use around controls, light bulb or any electrical part.
Door Gaskets	<ul style="list-style-type: none"> • Soap and water 	Wipe gaskets with a clean soft cloth.
Drawers/Bins	<ul style="list-style-type: none"> • Soap and water 	Do not wash any removable items (bins, drawers, etc.) in dishwasher.
Glass Shelves	<ul style="list-style-type: none"> • Soap and water • Glass cleaner • Mild liquid sprays 	Allow glass to warm to room temperature before immersing in warm water.
Toe Grille	<ul style="list-style-type: none"> • Soap and water • Mild liquid sprays • Vacuum attachment 	Vacuum dust from front of toe grille. Remove toe grille (See illustration on page 4). Vacuum backside and wipe with soft cloth or sponge. Rinse and dry.
Exterior and Handles	<ul style="list-style-type: none"> • Soap and water • Non Abrasive Glass Cleaner 	Do not use commercial household cleaners, ammonia, or other harsh chemicals to clean handles. Use a soft cloth to clean smooth handles. Not use a dry cloth to clean smooth doors.
Exterior and Handles (Stainless Steel Models Only)	<ul style="list-style-type: none"> • Soap and water • Ammonia • Stainless Steel Cleaners 	<p>CAUTION Never use CHLORIDE to clean stainless steel.</p> <p>Clean stainless steel front and handles with non-abrasive cleaner, warm water and a dishcloth. Rinse with clean water and a soft cloth. Wipe stubborn spots with an ammonia-soaked paper towel. Rinse and dry. Wipe with clean soft cloth. Rinse. Use a nonabrasive stainless steel cleaner. These cleaners can be purchased at most home improvement or major department stores. Always follow manufacturer's instructions.</p> <p>NOTE: Always, clean, wipe and dry with the grain to prevent cross-grain scratching. Wash the rest of the cabinet with warm water and mild liquid detergent. Rinse well, and wipe dry with clean soft cloth.</p>



Condenser Coils	<ul style="list-style-type: none"> • Vacuum attachment 	Use the dusting tool attachment on your vacuum to remove build-up on the condenser coils (see item “J” in illustration on page 17 for location).
-----------------	---	--

REPLACING LIGHT BULBS

1. Unplug refrigerator.
2. Wear gloves as protection against possible broken glass.
3. Remove light cover, if necessary.
4. Unscrew and replace old bulb with an appliance bulb of the same wattage.
5. Replace light cover, if necessary.
6. Remember to plug the refrigerator back in.

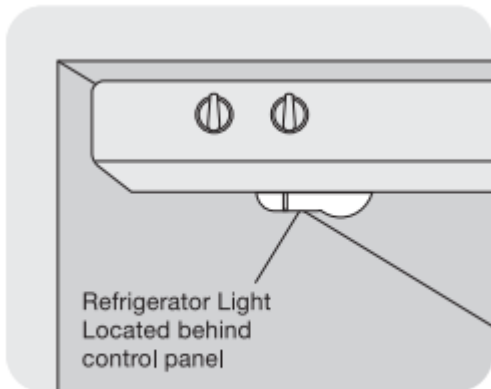

Refrigerator Light Replacement

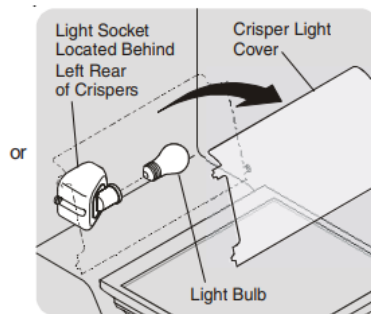
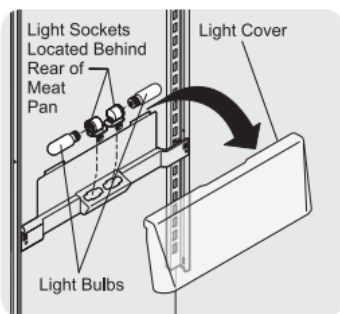

Crisper Light Replacement (Models may vary)

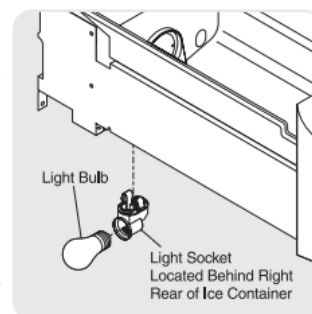

Freezer Light Replacement

Vacation and Moving Tips

Short Vacations	<ul style="list-style-type: none">• Leave refrigerator operating during vacations of 3 weeks or less.• Use all perishable items from refrigerator compartment.• Turn automatic ice maker off, even if you will only be gone for a few days.
Long Vacations	<ul style="list-style-type: none">• Remove all food and ice if you will be gone one month or more.• Turn controls to "O" (the OFF position) and disconnect power.• Turn off automatic ice maker and turn water supply valve to closed position.• Clean interior thoroughly.• Leave both doors open to prevent odors and mold build-up. Block doors open if necessary.
Moving	<ul style="list-style-type: none">• Remove all food and ice.• If using handcart, load from side.• Adjust rollers all the way up to protect them during sliding or moving.• Pad cabinet to avoid scratching surface.



BEFORE YOU CALL

PROBLEM	CAUSE	CORRECTION
RUNNING OF REFRIGERATOR		
Compressor does not run.	<ul style="list-style-type: none"> • Freezer control is set to "O". • Refrigerator is in defrost cycle. • Plug at wall outlet is disconnected. • House fuse blown or tripped circuit breaker. • Power outage. 	<ul style="list-style-type: none"> • Set freezer control. See Temperature Control section. • This is normal for a fully automatic defrost refrigerator. The defrost cycle occurs periodically lasting about 30 minutes. • Ensure plug is tightly pushed into outlet. • Check/replace fuse with a 15 amp time delay. Reset circuit breaker. • Check house lights. Call local Electric Company.
Refrigerator runs too much or too long.	<ul style="list-style-type: none"> • Room or outside weather is hot. • Refrigerator has recently been disconnected for a period of time. • Automatic ice maker is operating. • Doors are opened too frequently or too long. • Refrigerator/freezer door may be slightly open. • Freezer control is set too cold (control found in refrigerator section). • Refrigerator/freezer gasket is dirty, worn, cracked, or poorly fitted. • Condenser is dirty. 	<ul style="list-style-type: none"> • It's normal for the refrigerator to work longer under these conditions. • It takes 8-12 hours for the refrigerator to cool completely. • Ice maker operation causes refrigerator to run slightly more. • Warm air entering the refrigerator causes it to run more. Open doors less often. • Ensure refrigerator is level. Keep food and containers from blocking door. See PROBLEM SOLVING section OPENING/CLOSING OF DOOR AND DRAWERS. • Set refrigerator control to warmer setting. When refrigerator temperature is satisfactory. Allow 24 hours for temperature to stabilize. • Clean or change gasket. Leaks in door gasket cause refrigerator to run longer in order to reach desired temperatures. • Clean condenser. See <i>Care & Cleaning</i> Care and Cleaning section.



<p>Compressor goes off and on frequently.</p>	<ul style="list-style-type: none"> • Thermostat keeps the refrigerator at a constant temperature. 	<ul style="list-style-type: none"> • This is normal. Refrigerator goes on and off to keep temperature constant.
<p>TEMPERATURES ARE TOO COLD</p>		
<p>Freezer temperature too cold. Refrigerator temperature is satisfactory.</p>	<ul style="list-style-type: none"> • Freezer control is set too cold. 	<ul style="list-style-type: none"> • Set freezer control to a warmer setting. Wait 24 hours for temperature to stabilize.
<p>Refrigerator temperature too cold. Freezer temperature is satisfactory.</p>	<ul style="list-style-type: none"> • Refrigerator control is set too cold. 	<ul style="list-style-type: none"> • Set refrigerator control to a warmer setting. Wait 24 hours for temperature to stabilize.
<p>Food stored in drawers freezes.</p>	<ul style="list-style-type: none"> • Refrigerator control is set too cold. 	<ul style="list-style-type: none"> • See solution above.
<p>Food stored in Meat Keeper freezes (some models).</p>	<ul style="list-style-type: none"> • Meat Keeper Temperature Control set too cold. 	<ul style="list-style-type: none"> • Adjust Meat Keeper Temperature Control to a lower setting. (Meat should be stored at a temperature just below the freezing point for the maximum fresh storage time. It is normal for ice crystals to form due to the moisture content of meat.)



TEMPERATURES ARE TOO WARM		
Freezer/Refrigerator temperature is too warm.	<ul style="list-style-type: none"> • Doors are opened too frequently or too long. • Door is slightly open. • Condenser is dirty. 	<ul style="list-style-type: none"> • Warm air enters the refrigerator whenever the door is opened. Open the door less often. • See PROBLEM section OPENING/CLOSING DOORS/DRAWERS. • Clean condenser. See <i>Care & Cleaning</i> section.
Freezer temperature is too warm. Refrigerator temperature is satisfactory.	<ul style="list-style-type: none"> • Freezer control is set too warm. 	<ul style="list-style-type: none"> • Set freezer control to a colder setting. Allow 24 hours for temperature to stabilize.
Refrigerator temperature is too warm. Freezer temperature is satisfactory.	<ul style="list-style-type: none"> • Refrigerator control is set too warm. 	<ul style="list-style-type: none"> • Set refrigerator control to a colder setting. Allow 24 hours for temperature to stabilize.
Temperature in the Meat Keeper is too warm (some models).	<ul style="list-style-type: none"> • Meat Keeper Temperature Control is set too warm. 	<ul style="list-style-type: none"> • Adjust Meat Keeper Temperature Control to a colder setting.
WATER/MOISTURE/FROST INSIDE REFRIGERATOR		
Moisture collects on inside of refrigerator walls.	<ul style="list-style-type: none"> • Weather is hot and humid. • Door is slightly open. • Door is opened too often or too long. • Open containers. 	<ul style="list-style-type: none"> • The rate of frost buildup and internal sweating increases. • See PROBLEM section OPENING/CLOSING DOORS/DRAWERS. • Open door less often. • Keep containers covered.
Water collects on bottom side of drawer cover.	<ul style="list-style-type: none"> • Vegetables contain and give off moisture. 	<ul style="list-style-type: none"> • It is not unusual to have moisture on the bottom side of the cover. • Move humidity control (some models) to a drier setting.



<p>Water collects in bottom of drawer.</p>	<ul style="list-style-type: none"> • Washed vegetables and fruit drain while in the drawer. 	<ul style="list-style-type: none"> • Dry items before putting them in the drawer. Collecting in bottom of drawer is normal.
<p><i>WATER/MOISTURE/FROST OUTSIDE REFRIGERATOR</i></p>		
<p>Moisture collects on outside of refrigerator or between doors.</p>	<ul style="list-style-type: none"> • Weather is humid. • Door is slightly open, causing cold air from inside refrigerator to meet warm air from outside. 	<ul style="list-style-type: none"> • This is normal in humid weather. When weather is lower, the moisture should disappear. • See PROBLEM section OPENING/CLOSING REFRIGERATOR DOORS/DRAWERS.
<p><i>AUTOMATIC ICE MAKER</i></p>		
<p>Ice maker is not making any ice.</p>	<ul style="list-style-type: none"> • Ice maker wire signal arm is in the “up” or OFF position. • Household water line valve is not open. • Freezer is not cold enough. • Saddle valve on cold water pipe is clogged or restricted by foreign material. • Check to see if the water dispenser is dispensing water. 	<ul style="list-style-type: none"> • Move wire signal arm to the “down” or ON position. • Turn on household water line valve. • See PROBLEM section TEMPERATURE TOO WARM. • Turn off household water line valve. Replace saddle valve. Ensure that valve is not a self-piercing saddle valve. Clean valve. Replace valve if necessary. • If not, the ice & water filter cartridge is clogged or restricted by foreign material, and must be replaced.



Ice maker is not making enough ice.	<ul style="list-style-type: none"> • Ice maker is producing less ice than you expect. 	<ul style="list-style-type: none"> • Ice maker should produce approximately 4 pounds of ice every 24 hours. <i>Extra Ice</i> should produce up to 8 pounds of ice every 24 hours.
	<ul style="list-style-type: none"> • Freezer is not cold enough. 	<ul style="list-style-type: none"> • See PROBLEM section TEMPERATURE TOO WARM.
	<ul style="list-style-type: none"> • Household water line valve is not completely open. 	<ul style="list-style-type: none"> • Turn on household water line valve.
	<ul style="list-style-type: none"> • Check to see if water dispenser is dispensing slower than normal. 	<ul style="list-style-type: none"> • If it is, replace the ice & water filter cartridge.
Ice maker will not stop making ice.	<ul style="list-style-type: none"> • Ice maker wire signal arm is being held down by some item in the freezer. 	<ul style="list-style-type: none"> • Move item and release wire signal arm. Remove ice cubes that are frozen together over the arm.
Ice maker is not separating the ice	<ul style="list-style-type: none"> • Ice cubes are not being used frequently enough. 	<ul style="list-style-type: none"> • Remove and shake ice container to separate ice cubes.
cubes.	<ul style="list-style-type: none"> • Ice cubes are hollow or smaller than normal. 	<ul style="list-style-type: none"> • The ice & water filter cartridge may be clogged. Replace filter cartridge.
Ice has bad odor and taste.	<ul style="list-style-type: none"> • Ice has picked up odor or flavor from strong food stored in refrigerator or freezer. 	<ul style="list-style-type: none"> • Cover foods tightly. Discard stale ice. Ice maker will produce fresh supply.
	<ul style="list-style-type: none"> • Water running to ice maker has poor taste or odor. 	<ul style="list-style-type: none"> • Add filter to water supply line. Consult a water purifying company.
	<ul style="list-style-type: none"> • Ice not used frequently enough. 	<ul style="list-style-type: none"> • Discard stale ice.
ICE DISPENSER		
Dispenser will not dispense ice.	<ul style="list-style-type: none"> • Ice storage container is empty. 	<ul style="list-style-type: none"> • When the first supply of ice is dropped into container, the dispenser should operate.
	<ul style="list-style-type: none"> • Freezer temperature is set too warm. 	<ul style="list-style-type: none"> • Turn freezer control to a higher setting so ice cubes will be made. When first supply of ice is made, dispenser should operate.



	<ul style="list-style-type: none"> Household water line valve is not open. 	<ul style="list-style-type: none"> Open household water line valve. Allow sufficient time for the ice to be made. When ice is made, dispenser should operate.
	<ul style="list-style-type: none"> Freezer door is not closed. 	<ul style="list-style-type: none"> Ensure freezer door is closed.
	<ul style="list-style-type: none"> Ice dispensing arm has been held in for more than 4-5 minutes. 	<ul style="list-style-type: none"> Motor is overloaded. Motor overload protection resets in approximately 3 minutes. Ice can then be dispensed.
Ice dispenser is jammed.	<ul style="list-style-type: none"> Ice has melted and frozen around auger due to infrequent use, temperature fluctuations, and/or power outages. 	<ul style="list-style-type: none"> Remove ice container, thaw, and empty the container. Clean container, wipe dry, and replace in proper position. When new ice is made, dispenser should operate.
	<ul style="list-style-type: none"> Ice cubes are jammed between ice maker and back of ice container. 	<ul style="list-style-type: none"> Remove ice cubes that are jamming the dispenser.
	<ul style="list-style-type: none"> Ice cubes are frozen together. 	<ul style="list-style-type: none"> Use the dispenser often so that cubes do not freeze together.
	<ul style="list-style-type: none"> Ice cubes are hollow or smaller than normal. 	<ul style="list-style-type: none"> The ice & water filter cartridge could be clogged. Replace the filter cartridge. Dispensing system operates best at 30 - 100 psi water pressure. Household water pressures should fall within this range.



WATER DISPENSER		
Dispenser will not dispense water.	<ul style="list-style-type: none"> Household water line valve is not open. Freezer door is not closed. Ice & water filter cartridge is clogged. Front filter not fully installed, if equipped 	<ul style="list-style-type: none"> Open household water line valve. See ICE MAKER IS NOT MAKING ICE section. Ensure that freezer door is closed. Replace filter cartridge. Push filter in until you hear a “click”. Filter should be flush with cabinet.
Water has an odd taste and/or odor.	<ul style="list-style-type: none"> Water has been in the tank for a period of time. Unit not properly connected to cold water line. Tubing used in the household water supply and installation may affect water taste and odor. Water has a high mineral content. 	<ul style="list-style-type: none"> Draw and discard 10 - 12 glasses of water to freshen the supply and completely rinse the tank. Connect unit to cold water line that supplies water to the kitchen faucet. For best results, use copper tubing for water supply connections. Contact water treatment plant for help.
Water pressure is extremely low.	<ul style="list-style-type: none"> Cut-off and cut-on pressures are too low (well systems only). Reverse osmosis system is in regenerative phase. 	<ul style="list-style-type: none"> Have someone turn up the cut-off and cut-on pressure on the water pump system (well systems only). It is normal for a reverse osmosis system to have a pressure below 20 psi during the regenerative phase.
ODORS IN REFRIGERATOR		
Interior is dirty.	<ul style="list-style-type: none"> Interior needs to be cleaned. Food with strong odors is in refrigerator. 	<ul style="list-style-type: none"> See <i>Care & Cleaning Chart</i> in Care and Maintenance section. Cover food tightly.
OPENING/CLOSING OF DOORS/DRAWERS		



<p>Door(s) will not close.</p>	<ul style="list-style-type: none"> • Door was closed too hard, causing other door to open slightly. • Refrigerator is not level. It rocks on the floor when moved slightly. • Refrigerator is touching a wall or cabinet. 	<ul style="list-style-type: none"> • Close both doors gently. • Ensure floor is level and solid, and can support the refrigerator. Contact a carpenter to correct a sagging or sloping floor. • Ensure floor is level and solid, and can support the refrigerator. Contact a carpenter to correct a sagging or sloping floor.
<p>Drawers are difficult to move.</p>	<ul style="list-style-type: none"> • Food is touching shelf on top of drawer. • Track that drawers slide on is dirty. 	<ul style="list-style-type: none"> • Keep less food in drawer. • Clean drawer, rollers, and track. See <i>Cleaning Chart</i> in Care and Cleaning section.
<p>LIGHT BULB IS NOT ON</p>		
<p>Light bulb is not on.</p>	<ul style="list-style-type: none"> • Light bulb is burned out. • Light switch is stuck. • No electric current is reaching refrigerator. 	<ul style="list-style-type: none"> • See <i>Replacing Light Bulbs</i> in Care and Cleaning section. • Light switch is located on side of refrigerator freezer liners. • See PROBLEM section RUNNING OF REFRIGERATOR.

Warning

This content is compiled from multiple sources and is provided for reference purposes only. It may not be complete or fully applicable to all situations. If you are unable to resolve your issue, please contact the product manufacturer or an authorized service provider for official support.

