

## BEFORE SETTING SURFACE CONTROLS

### Assembly of the burner caps

Make sure that all of the surface burner caps and surface burner grates are installed correctly and at the correct locations.

1. Remove all packing material from the cooktop area.
2. Make sure burner caps are properly placed on the surface burners.
3. Unpack the burner grates and position them on the cooktop.
4. Discard all packing material.

On round-style burners, the burner cap lip (Figure 1) should fit snug into the center of the burner head and rest level. Refer to Figure 2 for correct and incorrect burner cap placement.

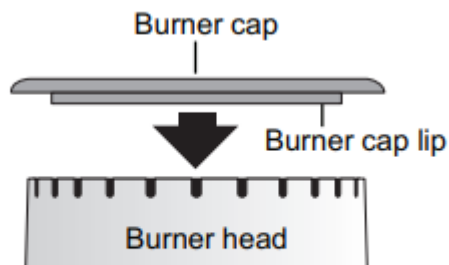

**Figure 1: Burner caps and burner heads**

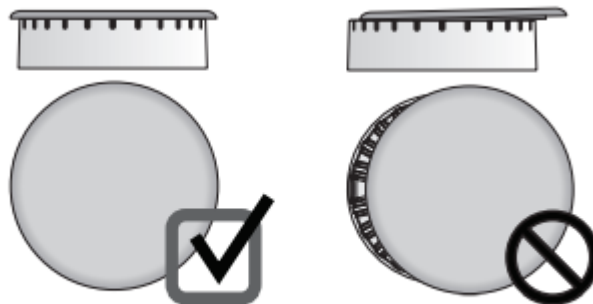
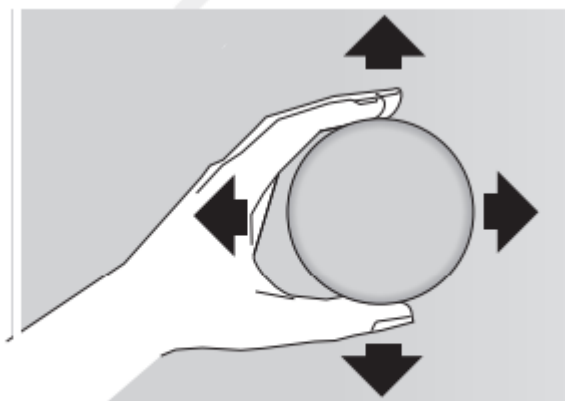

**Figure 2: Proper burner cap placement**

### CAUTION

- Do not allow spills, food, cleaning agents, or any other material to enter the gas orifice holder opening.
- Always keep the burner caps and burner heads in place whenever the surface burners are in use.
- Never place flammable items on the cooktop.

Once in place, you may check the fit by gently sliding the burner cap from side to side (Figure 3) to be sure it is centered and firmly seated. When the burner cap lip makes contact inside the center of the burner head you will be able to hear the burner cap click.



**Figure 3: Gently move cap for proper placement**

**IMPORTANT:** Please note that the burner cap should not move off the center of the burner head when sliding from side to side.

- Check and be sure that all oval-style burner caps (some models) are correctly in place on oval burner heads.
- Do not use the surface burners without the burner caps properly installed. Improperly seated burner caps may prevent burners from lighting or cause uneven flame and heating.
- Missing pieces or improper installation may lead to spills, burns, or damage to your range and cookware.
- Never place flammable items on the cooktop.

### **Install burner grates**

To install burner grates, place the grates flat-side down and align them into the cooktop recess.

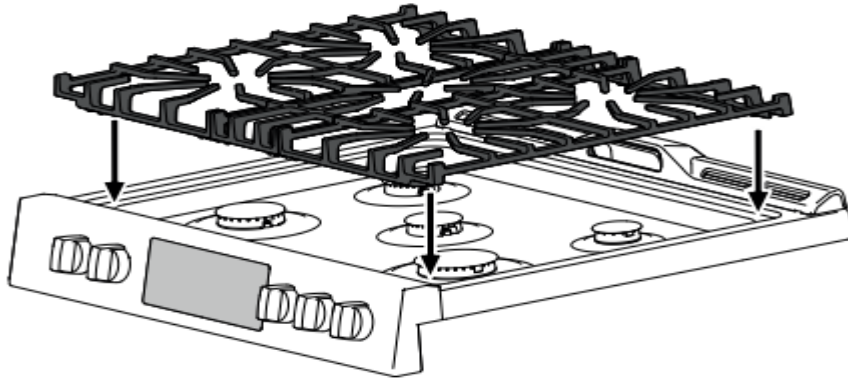

**Figure 4: Proper grate installation**

**IMPORTANT**

- Make sure the burner grates are properly placed on the cooktop before using the surface burners (Figure 4). The grates are designed to rest inside the recess on the cooktop.
- Grates should rest flush against each other and against the sides of the recess.
- Do not line the area underneath the grates or any part of the cooktop with aluminum foil or with any other lining.

NOTE: SCC message in display - If the cooktop is used during a self-clean cycle, the oven may turn off. The oven control display will show "SCC" for 5 seconds. The oven door will remain locked until the oven has cooled down below cleaning temperature. If the oven is below cleaning temperature, the user can start another clean cycle immediately. If the oven is in cleaning temperature range, another self-clean cycle can be set once the door unlocks (up to 4 hours).

**Using Proper Cookware**

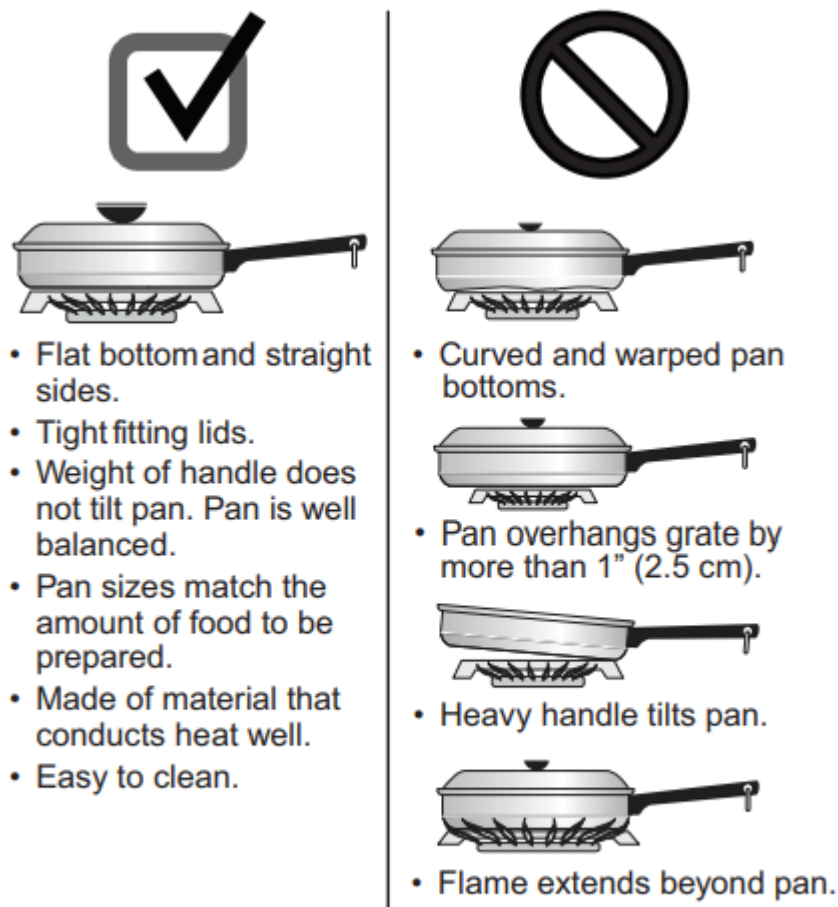

**Figure 5: Testing cookware**

- The size and type of cookware used will influence the heat setting needed for best cooking results. Be sure to follow the recommendations for using proper cookware as illustrated in Figure 5 and Figure 6.



- Check for flatness by rotating a ruler across the bottom of the cookware (See Figure 5). Cookware should have flat bottoms that make good contact with the entire surface heating element (See Figure 6).



**Figure 6: Proper cookware**

## Cookware Material Types

The cookware material determines how evenly and quickly heat is transferred from the surface burner to the pan bottom. The most popular materials available are:

- Aluminum - Excellent heat conductor. Some types of food will cause it to darken (Anodized aluminum cookware resists staining and pitting).
- Copper - Excellent heat conductor but discolors easily (See Aluminum).
- Stainless - Slow heat conductor with uneven cooking results. Is durable, easy to clean and resists staining.
- Cast Iron - A slow heat conductor that retains heat very well. Cooks evenly once cooking temperature is reached.

- Porcelain-enamel on metal - Heating characteristics will vary depending on base material.
- Glass - Slow heat conductor.

## Gas surface burner types

The cooktop is equipped with gas surface burners with different BTU ratings. The ability to heat food quickly and in large amounts increases as the burner size increases.

- Small burners are best used for low-flame heating of small amounts of food.
- Standard burners can be used for most surface cooking needs.
- The largest burner is best used for bringing large quantities of liquid rapidly up to temperature or when preparing larger quantities of food. The large burner is located at the right front position on the cooktop.

Regardless of size, always select cookware that is suitable for the amount and type of food being prepared. Select a burner and set the flame size appropriately for the pan. Never allow flames to extend beyond the outer edge of the pan.

## SETTING SURFACE CONTROLS

### Setting surface controls

The ability to heat food quickly and in large volumes increases as the burner size increases. Your gas appliance may be equipped with many different sized surface burners.

It is important to select cookware that is suitable for the amount and type of food being prepared. Select a burner and flame size appropriate for the cookware size.

- The standard size burner or burners may be used for most surface cooking needs.
- Small burners are best used for low-flame heating of small amounts of food.
- Large burners are best for bringing large quantities of liquid to temperature or heating larger quantities of food.

### Setting a surface burner:

1. Place cooking utensil on center of surface burner grate. Be sure the cooking utensil rests stable on the burner grate.
2. Push the burner's surface control knob in and turn counterclockwise out of the OFF position (Figure 7).
3. Release the surface control knob and rotate to the LITE position (  ). Visually check that the burner has a steady gas flame.

4. Once the surface burner has a flame, push the surface control knob in and turn counterclockwise to the desired flame size setting. Adjust the flame as needed using the knob markings.

**IMPORTANT:**

- NEVER place or straddle a cooking utensil over two different surface cooking areas at the same time unless the cookware is specifically designed for the purpose.
- DO NOT cook with a surface control knob left in the lite position (  ). The electronic ignitor will continue to spark. Turn the control knob out of the lite position and adjust the flame size.
- Do not place aluminum foil, or ANY material that can melt on the range cooktop. If items melt, they may permanently damage the appearance of the cooktop.

**CAUTION:** Do not place flammable items such as plastic wrappings, spoon holders, or plastic salt and pepper shakers on the cooktop when it is in use. These items could melt or ignite. Potholders, towels, or wooden spoons could catch fire if placed too close to the surface burners.

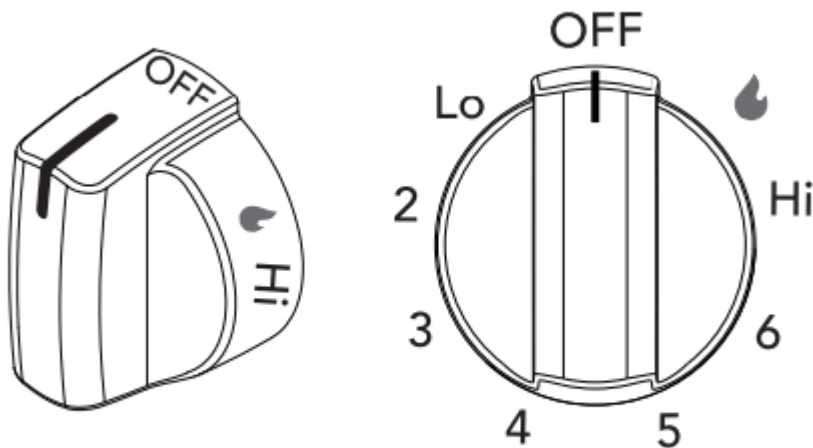

**Figure 7: Surface control knob**

**NOTE**

- When setting a surface control knob to the lite position, all of the electronic surface ignitors will spark at the same time. However, only the surface burner you are setting will ignite.
- In the event of an electrical power outage, the surface burners may be lit manually. To light a surface burner, hold a lit match to the burner head, then slowly turn the surface control knob to lite. Once the burner ignites, push in and turn knob out of lite then to the desired flame setting. Use caution when lighting surface burners manually

## Set proper burner flame size

- The color of the flame is the key to proper burner adjustment. A good flame is clear, blue and hardly visible in a well-lighted room. Each cone of flame should be steady and sharp. Adjust or clean the burner if flame is yellow-orange.
- For most cooking: start on the highest setting and then turn to a lower setting to complete the process. Use the recommendations below as a guide for determining proper flame size for various types of cooking (Figure 9).
- For deep fat frying: use a thermometer and adjust the surface knob accordingly. If the fat is too cool, the food will absorb the fat and be greasy. If the fat is too hot, the food will brown so quickly that the center will be under-cooked. Do not attempt to deep fat fry too much food at once as the food will neither brown nor cook properly



**Figure 8: Flame settings**

| Flame size  | Type of cooking   |
|---|---|
| High flame  | Start most foods; bring water to a boil; pan broiling   |
| Medium flame  | Maintain a slow boil; thicken sauces, gravies; steaming |
| Low flame   | Keep foods cooking; poaching; stewing                   |
| These settings are based on medium-weight metal or aluminum pans with lids. Settings may vary when using other types of pans. |   |

**Figure 9: Recommended flame settings for cooking**

## Home Canning

Be sure to read and observe all the following points when home canning with your appliance. Check with the USDA (United States Department of Agriculture) Web site and be sure to read all

the information they have available as well as follow their recommendations for home canning procedures.

- Use only a completely flat bottom canner with no ridges that radiate from the bottom center when home canning. Heat is spread more evenly when the bottom surface is flat. Use a straight-edge to check canner bottom.
- Make sure the diameter of the canner does not exceed 1 inch beyond the surface element markings or burner.
- It is recommended to use smaller diameter canners on electric coil and ceramic glass cooktops and to center canners on the burner grates.
- Start with hot tap water to bring water to boil more quickly.
- Use the highest heat setting when first bringing the water to a boil. Once boiling is achieved, reduce heat to lowest possible setting to maintain that boil.
- Use tested recipes and follow instructions carefully. Check with your local Cooperative Agricultural Extension Service or a manufacturer of glass jars for the latest canning information.
- It is best to can small amounts and light loads.
- Do not leave water bath or pressure canners on high heat for an extended amount of time.

## **BEFORE SETTING OVEN CONTROLS**

### **Oven Vent Location**

- The oven is vented as shown below. When the oven is on, warm air is released through the vent. This venting is necessary for proper air circulation in the oven and good baking results. Do not block oven vent. Never close off the openings with aluminium foil or any other material. Steam or moisture may appear near the oven vent. This is normal.

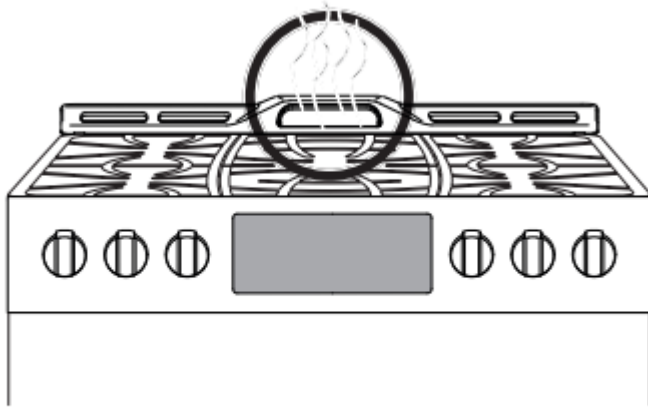

**Figure 10: Oven vent**

### Types of oven racks

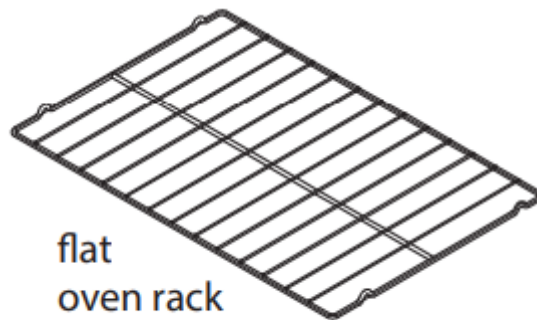

**Figure 11: Oven rack types**

- Flat oven racks may be used for all cooking needs and may be placed in most oven rack positions.

Removing, replacing, and arranging flat oven racks

### **Always arrange the oven racks when the oven is cool.**

- To remove - Pull the oven rack straight forward until it reaches the stop position. Lift up front of oven rack slightly and slide out.
- To replace - Place the oven rack on the rack guides on both sides of oven walls. Tilt the front of oven rack upward slightly and slide the oven rack back into place. Be sure oven racks are level before using.

# SETTING OVEN CONTROLS

## Oven Control Features

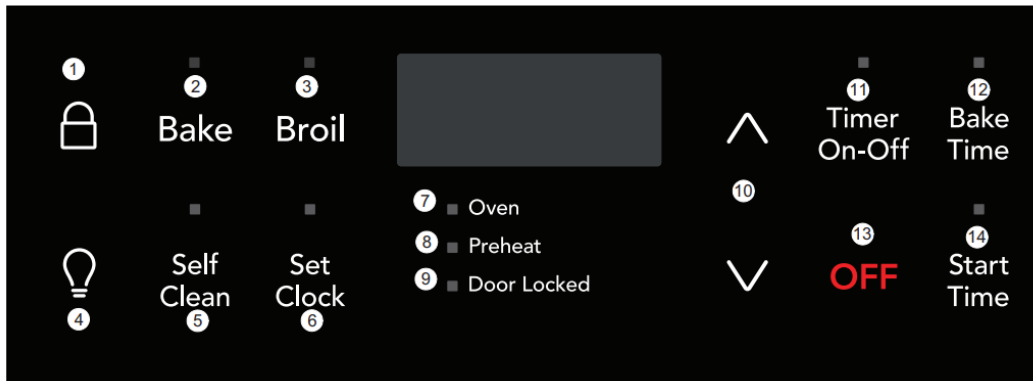

1. Control Lock - Use to lock all oven controls. (Locks oven door and controls on Self Clean model.)
2. Bake - Use to select bake feature.
3. Broil - Use to set Broil feature.
4. Oven Light - Use to turn on oven light when checking on food. Turns on when the oven door is open.
5. Self Clean - Use to with arrow keys to set self clean cycle of 2 or 3 hours.
6. Set Clock - Use with arrow keys to set the time of day.
7. Oven on indicator light - Glows each time the oven turns on to maintain the set oven temperature.
8. Preheat light - The preheat light will glow when the oven is preheating.
9. Door locked - The door locked light will flash when the oven door locks and unlocks, and remain on when the self clean cycle feature is active.
10. Up and Down arrows - Use with the control keys to set oven temperature, bake time, start time, clean time, and setting or adjusting the clock and minute timer.
11. Timer on-off - Use to set or cancel the minute timer.
12. Bake Time - Enters the length of baking time desired.
13. OFF - Use to clear any feature except the time of day and minute timer.
14. Start Time - Used with Bake and Self Clean to set a delayed starting time.



| Feature         | Mode   | Min Temp/ Time      | Max Temp/ Time   |
|-----------------|--------|---------------------|------------------|
| Bake            |        | 170°F (77°C)        | 550°F (287°C)    |
| Broil           |        | LO 400°F<br>(205°C) | HI 550°F (287°C) |
| Timer           | 12 Hr. | 0:01 Min.           | 11:59 Hr./Min.   |
| Clock Time      | 12 Hr. | 1:00 Hr./Min.       | 12:59 Hr./Min.   |
| Bake Time       | 12 Hr. | 0:01 Min            | 5:59 Hr./Min.    |
| Self Clean Time |        | 2 hours             | 3 hours          |

Note: An entry acceptance tone (1beep) will sound each time a key is touched (the oven lock key is delayed 3 seconds). An entry error tone (3 short beeps) will sound if the entry of the temperature or time is below the minimum or above the maximum settings for the feature.

## Setting the Clock

When the appliance is first plugged in or when the power supply to the appliance has been interrupted, the display will flash 12:00. It is recommended to always set the clock for the correct time of day before using the appliance.



To set the clock:

1. Press Set Clock once (do not hold clock key down).
2. Within 5 seconds, press and hold  or  until the correct time of day appears in the display.

## Temperature display (Fahrenheit/Celsius)

The electronic oven control is set to operate in Fahrenheit (°F) at the factory. The oven may be programmed for any temperature from 170°F to 550°F (77°C to 287°C).

To change the temperature to Celsius (°C) or from °C to °F:

1. Press Broil. — — appears in the display.
2. Press and hold  until HI appears in the display.
3. Press and hold Broil until °F or °C appears in the display.
4. Press  or  to change °F to °C or °C to °F. To accept the change, wait 6 seconds.

## Changing between continuous bake setting or 12- hour energy saving feature

The oven control has a built-in 12-hour energy saving feature that will shut off the oven if the oven is left on for more than 12 hours. The oven control can be programmed to override this feature for continuous baking.

To change the continuous bake setting:

1. Press and hold Timer on-off for 6 seconds until a tone sounds. — — hr will appear in the display for continuous cooking. The current time of day will return to the display.
2. To cancel the continuous bake setting, press Timer onoff and hold for 6 seconds until a tone sounds. 12 hr will appear in display indicating that the control has returned to the 12-hour energy saving feature.

## Setting a silent control panel

When selecting a function, an audible tone is heard each time a key is pressed. If desired, the control can be programmed for silent operation.

To set the controls for silent operation:

1. Press and hold Start Time for 6 seconds. The control will beep once and release the key.
2. The controls are now set for silent operation.

To return to non-silent operation:

1. Press and hold Start Time again for 6 seconds until the control beeps once and release the key.
2. The control is now set for audible operation.

## Setting oven lock

The control can be programmed to lock the oven door and lockout the oven control keypad on the Self Clean model. On the Steam Clean model the lock icon will lock the oven controls only.



To set the oven lockout feature:

1. Press OFF and hold for 6 seconds. Loc will appear in display, the door locked indicator light will flash, and the motor driven door lock will begin to close on the Self Clean model. Allow about 15 seconds for the oven door to lock. Once the oven door is locked, the current time of day will appear in the display.
2. To cancel the Oven Lock feature, press OFF and hold for 6 seconds. Allow about 15 seconds for the oven door to lock. Once the oven door is locked, the current time of day will appear in the display. The control will unlock the oven door and resume normal operation



## Operating oven light

- The interior oven light will automatically turn on when the oven door is opened. Press the oven light key located on the control panel to turn the interior oven light on and off whenever the oven door is closed. For best baking results, do not leave oven light on while baking.
- The interior oven light is located at the upper left rear wall of the oven interior. To change the interior oven light, see “Changing the oven light” in the Care & cleaning section.

## Setting the minute timer

1. Press Timer on-off.
2. Press  to increase time in one-minute increments. Press and hold  to increase time in 10-minute increments. The timer can be set for any amount of time from 1 minute to 11 hours and 59 minutes.
3. When the desired time appears in the display, release the . The timer will begin to countdown in about 5 seconds.
4. To turn the timer off at any time Press Timer on-off.
5. When the set time ends, the timer will beep three times and will continue to beep three times every minute until Timer on-off is pressed.

### To change the timer while it is in use:

While the timer is active and shows in the display, press and hold  or  to increase or decrease the time remaining.

### To cancel the minute timer before the set time has run out:

- Press Timer on-off once.

## Setting Bake

The oven can be programmed to bake at any temperature from 170°F to 550°F (77°C to 287°C). The factory preset automatic bake temperature is 350°F (177°C).

The oven indicator light will turn on when first set to bake while the oven is heating. When the set temperature is reached the oven control will beep once indicating the oven is fully preheated and time to place food in the oven. The indicator light will cycle on and off as the oven maintains the set temperature.

### For best bake results:

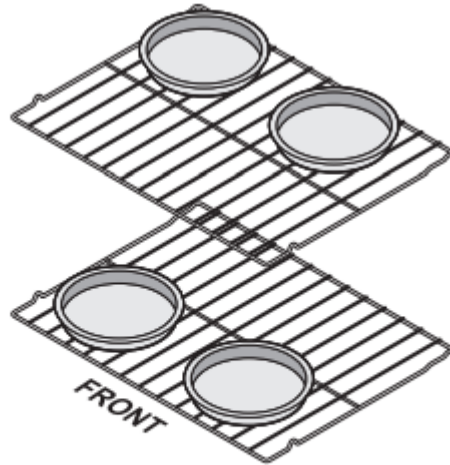

- Fully preheat the oven before baking.
- When baking items like cookies, cakes, biscuits, and breads using a single rack place rack in position 3.

- When using any single rack for items like frozen pies, angel food cake, breads, and casseroles, use rack position 4.
- For best results when baking cakes using two oven racks, place racks in positions 2 and 4 (See Figure 13).
- When baking cakes using two oven racks, position cookware as shown in Figure 12. Allow at least 2 inches (5 cm) of space between cookware for proper air circulation





**Figure 12: Pan positions two rack baking**

**To set Bake:**

1. Press Bake. — — — appears in the display.
2. Within 5 seconds, press  or . The display will show 350°F (177°C). The temperature can then be adjusted in 5°F (1°C) increments.
3. When a key is released, the oven will begin heating to the selected temperature. When the oven reaches the set temperature, the preheat indicator light will turn off and the control will beep three times.
4. To cancel the baking function, press OFF.

**To change oven temperature after bake has started:**

1. Press Bake.
2. Press  or  to increase or decrease to a new temperature. The oven indicator light on the electronic display will turn on and off when using the bake feature and during preheat. This is normal and indicates that the oven is cycling to maintain the selected baking temperature. To cancel baking press OFF.

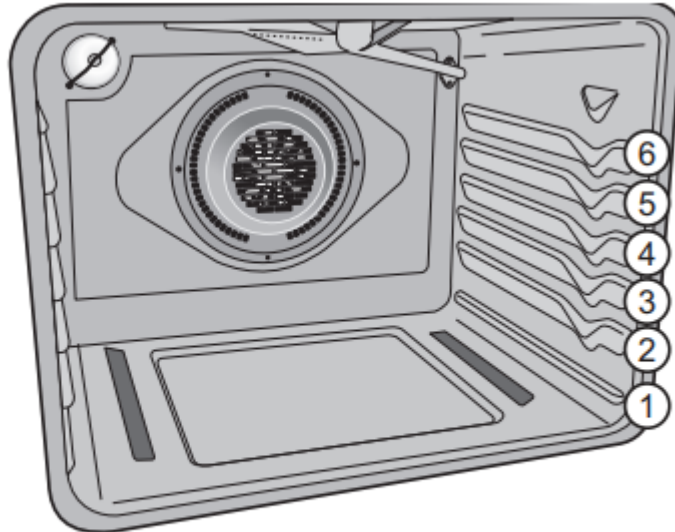





**Figure 13: Rack positions for visible bake and hidden bake elements**

## Setting Bake Time

The Bake Time key sets the amount of time needed for baking. The oven will turn on immediately and stop automatically after the set bake time ends.

**To program the oven to begin baking immediately and to shut off automatically (timed bake):**

1. Be sure the clock is set to the correct time of day.
2. Place the food in the oven.
3. Press Bake. — — — ° appears in the display.
4. Within 5 seconds, press  or . The display will show 350°F (177°C). The temperature can then be adjusted in 5°F (1°C) increments,
5. Press Bake Time.0:00 will appear in the display.
6. Press  or  until the desired baking time appears in the display.
7. The oven will turn on and begin heating.







**When the set bake time runs out:**

1. End will appear in the display, and the oven will shut off automatically.
2. The control will beep three times every 60 seconds as a reminder until OFF is pressed.



## Setting Start Time (delayed start)

Use the Start Time key to delay the starting time (delayed timed bake). The oven will turn on at a later time and stop automatically after the set bake time ends.

### To program oven for a delayed start time and to shut-off automatically:

1. Be sure that the clock displays the correct time of day.
2. Place food in the oven.
3. Press Bake. — — — ° appears in the display. Within 5 seconds, press  or . The display will show 350°F (177°C). The temperature can then be adjusted in 5°F (1°C) increments.
4. Press Bake Time. 0:00 will appear in the display.
5. Press  or  until desired baking time appears.
6. Press Start Time. The time of day will appear in the display.
7. Press  or  until the desired start time appears in the display.
8. Once the controls are set, the control calculates the time when baking will stop. The oven will turn on at the delayed start time and begin heating.

To change the oven temperature (or bake time) after baking has started:

1. Press the function you want to change.
2. Press  or  to adjust the setting.

## Setting Broil

- Broiling is direct heat cooking and will produce some smoke. If smoke is excessive, place food further away from the element. Watch food to prevent burning. Broil with the oven door closed.
- When broiling, always remember to arrange the oven racks while oven is still cool. Position the rack as suggested in Table 1.



**WARNING:** Broil with the oven door closed. Should an oven fire occur, close the oven door and turn the oven off. If the fire continues, use a fire extinguisher. Do not put water or flour on the fire. Flour may be explosive.

**CAUTION:** Always use oven mitts. Oven racks will become very hot which can cause burns.

**NOTE:** Always pull the oven rack out to the stop position before turning or removing food. The broiler pan and the insert (some models) allow grease to drain and be kept away from the high heat of the broiler. Do not use the pan without the insert. Do not cover the insert with aluminum foil; the exposed grease could ignite.

**IMPORTANT:** If the oven door is left open during broil the high temperatures can trigger a door open alarm. The control will beep and (dO) will appear in the display. If the oven door is not closed within 30 seconds, the broil element will turn off. If this occurs, close the oven door and check if broil function resumes. If not, reset the function and broil with oven door closed.

To set Broil

1. Arrange the oven rack while oven is still cool.
2. Press Broil. — — will appear in display.
3. Press  for HI broil or  for LO broil. Most foods may be broiled at the HI broil setting. Select the LO broil setting to avoid excess browning or drying of foods that should be cooked to the well-done stage.
4. For optimum results, preheat broil for 2-to-5 minutes before adding food.
5. Place the insert on the broil pan (if equipped), then place the food on the broil pan insert (if using a broiler pan and insert).
6. Place the broiler pan and insert on the oven rack. Broil with the oven door closed.
7. Broil on one side until food is browned. Turn and broil food on other side.
8. When broiling is finished press OFF.

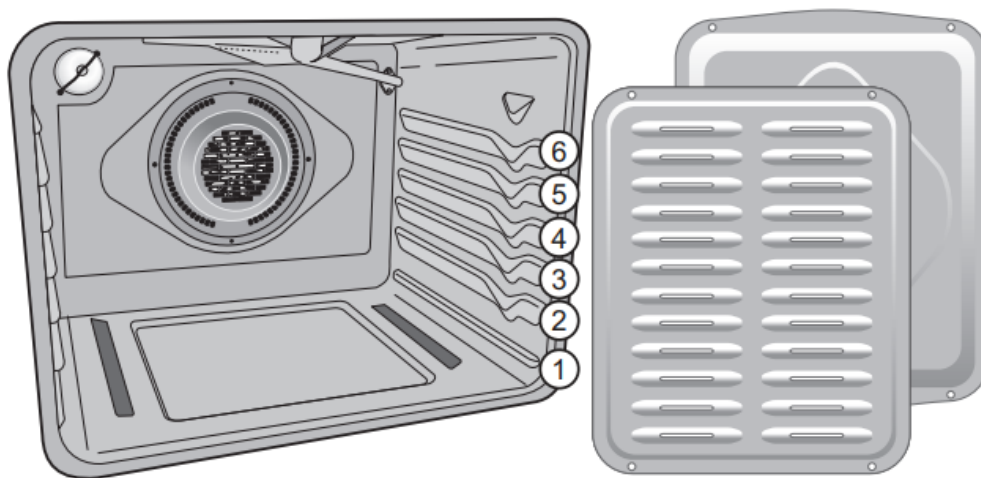

**Figure 14:** Rack positions; Broil pan and insert

**Table 1: Broil recommendations**

| Food item             | Rack Position | Temp      | Cook time in minutes |          | Internal Temperature | Doneness    |
|-----------------------|---------------|-----------|----------------------|----------|----------------------|-------------|
|                       |               |           | 1st side             | 2nd side |                      |             |
| Steak 1" thick        | 6             | HI(550°F) | 6:00                 | 4:00     | 135°F (57°C)         | Rare**      |
| Steak 1" thick        | 6             | HI(550°F) | 7:00                 | 5:00     | 145°F (63°C)         | Medium-well |
| Steak 1" thick        | 6             | HI(550°F) | 8:00                 | 7:00     | 170°F (77°C)         | Well        |
| Pork Chops 3/4 "thick | 5             | HI(550°F) | 8:00                 | 6:00     | 170°F (77°C)         | Well        |
| Chicken - Bone In     | 4             | LO(400°F) | 20:00                | 10:00    | 170°F (77°C)         | Well        |
| Chicken Boneless      | 5             | LO(400°F) | 8:00                 | 6:00     | 170°F (77°C)         | Well        |
| Fish                  | 5             | HI(550°F) | 13:00                | --       | 170°F (77°C)         | Well        |
| Shrimp                | 4             | HI(550°F) | 5:00                 | --       | 170°F (77°C)         | Well        |
| Hamburger 1" thick    | 6             | HI(550°F) | 6:00                 | 4:00     | 135°F (57°C)         | Rare**      |
| Hamburger 1" thick    | 6             | HI(550°F) | 9:00                 | 7:00     | 145°F (63°C)         | Medium      |
| Hamburger 1" thick    | 5             | HI(550°F) | 10:00                | 8:00     | 170°F (77°C)         | Well        |

The U.S. Department of Agriculture states, "\*\*Rare fresh beef is popular, but you should know that cooking it to only 140°F (60°C) means some food poisoning organisms may survive." (Source: Safe Food Book, Your Kitchen Guide, USDA Rev. June 1985.) The lowest temperature recommended by the USDA is 145°F (63°C) for medium rare fresh beef. For well done 170°F (77°C). All cook times shown are after 2 minutes of preheating.

## Self Clean

- On models with self cleaning feature: A self cleaning oven cleans itself with temperatures well above normal cooking temperatures which eliminate soils completely or reduces them to a fine powdered ash you can wipe away with a damp cloth. While the oven is in operation, the oven heats to temperature much higher than those used in normal cooking. Sounds of metal expansion and contraction are normal. Odor is also normal because the food soil is being removed. Smoke may appear through the oven vent.

## CAUTION

- During the self cleaning cycle, the outside of the range can become very hot to the touch.
- Do not leave small children unattended near appliance. During self clean cycle, the outside of the oven can become very hot and cause burns if touched.
- To avoid possible burns, use care when opening the oven door after the self cleaning cycle. Stand to the side of the oven when opening the door to allow hot air or steam to escape.
- Do not line the oven walls, racks, bottom, or any other part of the range with aluminum foil. Doing so will destroy heat distribution, produce poor baking results, and cause permanent damage to the oven interior (aluminum foil will melt to the interior surface of the oven).
- The health of some birds is extremely sensitive to the fumes given off during the self cleaning cycle of any range. Move birds to another well-ventilated room.

- Do not force the oven door open. This can damage the automatic door locking system. Use caution when opening the door after the self cleaning cycle is complete. The oven may still be very hot.





**Figure 15: Clean around the oven door gasket**

IMPORTANT: Adhere to the following self clean precautions:

- Do not use oven cleaners or oven protective coatings in or around any part of the oven interior.
- Do not clean the oven door gasket (Figure 15). The woven material of the oven door gasket is essential for a good seal. Care should be taken not to rub, damage, or remove the gasket.
- Do not use any cleaning materials on the oven door gasket. Doing so could cause damage.
- Remove all items from the oven and cooktop including cookware.
- Remove the broiler pan and insert, all utensils, and any aluminum foil. These items cannot withstand high cleaning temperatures and will melt.
- Completely remove all oven racks and any accessories. If the oven racks are not removed, they will lose their special coating properties and no longer slide in and out of the oven cavity easily.
- Remove any excessive spills. Any spills on the oven bottom should be wiped-up and removed before starting the self cleaning cycle. To clean, use hot, soapy water and a cloth. Large spills can cause heavy smoke or fire when subjected to high temperatures.
- Do not allow food spills with a high sugar or acid content (such as milk, tomatoes, sauerkraut, fruit juices, or pie filling) to remain on the surface as they may leave a dull spot even after cleaning.
- Clean any soil from the oven frame, the door liner outside the oven door gasket, and the small area at the front center of the oven bottom. These areas heat sufficiently to burn soil on. Clean with soap and water. These areas are shown in white (Figure 15).

NOTE: Remember the range door cannot be opened until the range has cooled sufficiently. You will need to add about 1 hour to the time displayed before you can use the range for cooking

### To set a self clean cycle:

1. Press Self Clean. --- appears in the display.
2. Press  until 3:00 appears in the display for a 3 hour self clean process, or push  until 2:00 appears in the display for a 2 hour self clean process.
3. As soon as the controls are set, the motor driven lock will begin to close automatically and the door locked indicator light will flash. Do not open the oven door while the light is flashing (allow about 15 seconds for the oven door to lock).
4. CLn will appear in the display during the self clean cycle, and the door locked light will glow until the self cleaning cycle is complete or cancelled and the oven temperature has cooled.

### When the self clean cycle has completed:

- The time of day will appear in the display window, and the Clean key and door locked light will continue to glow.
- Once the oven has cooled down for about 1 hour and the door locked light has gone out, the oven door may be opened.
- To avoid possible burns, use care when opening the oven door after the self cleaning cycle. Stand to the side of the oven when opening the door to allow hot air or steam to escape.

### To stop or interrupt a self clean cycle (once it has been activated):



1. Press OFF.
2. Once the oven has cooled down for about 1 hour and the door locked light has turned off, the oven door can be opened.
3. Restart the self clean cycle once all conditions have been corrected.

IMPORTANT: If the cooktop is used during a self-clean cycle, the oven may turn off. The oven control display will show "SCC" for 5 seconds. The oven door will remain locked until the oven has cooled down below cleaning temperature. If the oven is below cleaning temperature, the user can start another clean cycle immediately. If the oven is in cleaning temperature range, another self-clean cycle can be set once the door unlocks (up to 4 hours).

NOTE: SCC message in display - If the cooktop is used during a self-clean cycle, the oven may turn off. The oven control display will show "SCC" for 5 seconds. The oven door will remain locked until the oven has cooled down below cleaning temperature. If the oven is below cleaning temperature, the user can start another clean cycle immediately. If the oven is in cleaning temperature range, another self-clean cycle can be set once the door unlocks (up to 4 hours).

### Setting Delay Start Self Clean

To start a delay self clean with default clean time of 3 hours and a start time of 9:00 o'clock: Be sure the clock is set with the correct time of day, the oven is empty, and all oven racks are removed. Be sure oven door is completely closed.



1. Press Start Time and scroll  to 9 0 0 and release key.
2. Press Self Clean. --- appears in the display.
3. Press  until 3:00 appears in the display for a 3 hour self clean process, or push  until 2:00 appears in the display for a 2 hour self clean process.
4. The motor driven lock will begin to close automatically and the door locked indicator light will flash. Do not open the oven door while the light is flashing (allow about 15 seconds for the oven door to lock).
5. CLn will appear in the display during the self clean cycle, and the door locked light will glow until the self cleaning cycle is complete or cancelled and the oven temperature has cooled.

## Adjusting the oven temperature

Your appliance has been factory calibrated and tested to ensure an accurate baking temperature. For the first few uses, follow your recipe times and temperature recommendations carefully. If you think the oven is cooking too hot or too cool for your recipe times, you can adjust the control so the oven cooks hotter or cooler than the temperature displayed.

NOTE: Do not use oven thermometers such as those found in grocery stores to check the temperature settings inside your oven. These oven thermometers may vary as much as 20 to 40 degrees from actual temperatures. Oven temperature adjustments do not change the or functions. If the screen is set to degrees Celsius, adjustments are made in increments of 1 ° C each time the arrow keys are pressed.

### To adjust oven temperature:

1. Press Bake.
2. Set the temperature to 550°F (287°C) by pressing and holding .
3. Within 3 seconds, press and hold Bake until numeric digit(s) appear. Release Bake key. The display now indicates the amount of degrees offset between the original factory temperature setting and the current temperature setting. If the oven control has the original factory calibration, the display will read 00.
4. The temperature can now be adjusted up or down 35°F (19°C), in 5°F (1°C) increments. Press and hold  to adjust the temperature higher until the desired amount of offset appears in the display. When lowering the oven temperature using , a minus sign

(-) will appear before the number to indicate that the oven will be cooler by the displayed amount of degrees.

5. When you have made the desired adjustment, press OFF to go back to the time of day display

## CARE AND CLEANING

Remove spills and any heavy soiling as soon as possible. Regular cleaning will reduce the difficulty of major cleaning later.

### CAUTION

- Before cleaning any part of the appliance, be sure all controls are turned off and the appliance is cool.
- If ammonia or appliance cleaners are used, they must be removed and the appliance must be thoroughly rinsed before operating. Follow manufacturer's instructions and provide adequate ventilation

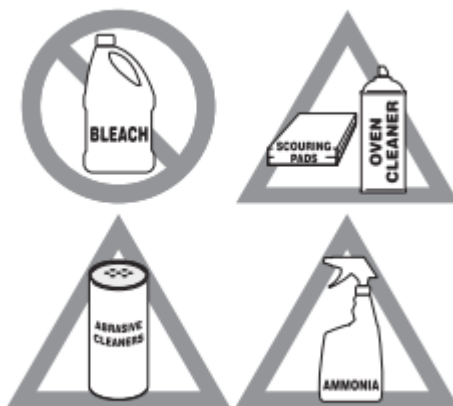

**Figure 16: Use cleaners with caution**

| Surface or Area   | Cleaning Recommendation  |
|---|--|
| Aluminum and vinyl  | Using a soft cloth, clean with mild dish detergent and water. Rinse with clean water, dry and polish with a soft, clean cloth.   |
| Painted and plastic control knobs<br>Painted body parts<br>Painted decorative trims       | Using a soft cloth, clean with mild dish detergent and water or a 50/50 solution of vinegar and water. Rinse with clean water, dry and polish with a soft, clean cloth. Glass cleaners may be used, but do not apply directly to surface; spray on a cloth and wipe.   |
| Control panel   | Using a soft cloth, clean with mild dish detergent and water or a 50/50 solution of vinegar and water. Do not spray liquids directly on the oven control and display area. Do not use large amounts of water on the control panel - excess water on the control area may cause damage to the appliance. Do not use other liquid cleaners, abrasive cleaners, scouring pads, or paper towels - they will damage the finish.   |
| Control knobs   | Using a soft cloth, clean with mild dish detergent and water or a 50/50 solution of vinegar and water. To remove control knobs: turn to the OFF position, grasp the knob firmly, and pull off the shaft. To replace knobs after cleaning, line up the O-rings and markings and push the knobs into place.  |
| Stainless Steel   | Using a soft cloth, clean with mild dish detergent and water or a 50/50 solution of vinegar and water. Rinse with clean water, dry with a soft clean cloth. Do not use cleaners containing abrasives, chlorides, chlorine, or ammonia.   |
| Smudge Proof™ Stainless Steel<br>Black Stainless Steel                                    | Using a soft cloth, clean with mild dish detergent and water or a 50/50 solution of vinegar and water. Rinse with clean water, dry with a soft clean cloth. Do not use appliance cleaner, stainless steel cleaner, or cleaner containing abrasives, chlorides, chlorine, or ammonia. These cleaners may damage the finish.   |
| Porcelain-enameled broiler pan and insert<br>Porcelain door liner<br>Porcelain body parts | Rinse with clean water and a damp cloth. Scrub gently with a soapy, non-abrasive scouring pad to remove most spots. Rinse with a 50/50 solution of water and ammonia. If necessary, cover difficult spots with an ammonia-soaked paper towel for 30 to 40 minutes. Rinse and wipe dry with a clean cloth. Rinse with all cleaners or future heating could damage the porcelain. Do not allow food with a high sugar or acid content (milk, tomatoes, sauerkraut, fruit juices or fillings) to remain on porcelain surfaces. These spills may cause a dull spot after cleaning. |
| Self-cleaning oven interior   | Before setting a self-clean cycle, clean soils from the oven frame, areas on the oven door gasket, and the small area at the front center of the oven body. See “Self Clean” on <a href="#">page 26</a> .  |

|                             |  |
|-----------------------------|--|
| Oven door                   | <p>Use mild dish detergent and water or a 50/50 solution of vinegar and water to clean the top, sides, and front of the oven door. Rinse well. Glass cleaner can be used on the outside glass of the door. Ceramic smoothtop cleaner or polish can be used on the interior door glass. Do not immerse the door in water. Do not spray or allow water or cleaners to enter the door vents. Do not use oven cleaners, cleaning powders, or any harsh abrasive cleaning materials on the outside of the oven door.</p> <p>Do not clean the oven door gasket. The oven door gasket is made of a woven material which is essential for a good seal. Do not rub, damage, or remove the gasket.</p> |
| Gas cooktop surface burners | See <a href="#">“Cleaning the sealed burners”</a> on <a href="#">page 31</a> .   |
| Gas cooktop surface grates  | Use a non-abrasive plastic scrubbing pad and mild abrasive cleanser. Do not allow food spills with a high sugar or acid content (milk, tomatoes, sauces, fruit juices or pie filling) to remain on the burner grates or burner caps. These spills may cause a dull spot even after cleaning. Clean these spills as soon as the surfaces are cool. Thoroughly dry immediately following cleaning.   |
| Gas cooktop burner caps     |  |

## Aluminum Foil and Utensils

### WARNING

- Never cover any slots, holes, or passages in the oven bottom or cover an entire oven rack with materials such as aluminum foil. Aluminum foil linings may trap heat, causing a fire hazard.
- Protective Liners — Do not use aluminum foil to line the oven bottom. Improper installation of these liners may result in risk of electric shock or fire.

## Cleaning the sealed burners

### IMPORTANT

- Aluminum foil - Use of aluminum foil on a hot cooktop can damage the cooktop. Do not use thin aluminum cooking utensils or allow aluminum foil to touch the surface elements under any circumstances.
- Aluminum utensils - The melting point of aluminum is much lower than that of other metals. Care must be taken when aluminum pots or pans are used on the cooktop. If aluminum pans are allowed to boil dry when using the cooktop, not only will the utensil be damaged or destroyed, but it may fuse to, break, or mark the ceramic glass surface, permanently damaging the cooktop surface.

To avoid possible burns, do not attempt cleaning before turning off all surface burners and allowing them to cool.

Any additions, changes, or conversions required in order for this appliance to satisfactorily meet the application needs must be made by an authorized qualified Agency. Routinely clean the cooktop. Wipe with a clean, damp cloth and wipe dry to avoid scratches. Keeping the surface burner head ports and slots clean will prevent improper ignition and an uneven flame.

To clean recessed and contoured areas of cooktop:

- If a spill occurs on or in the recessed or contoured areas, blot up spill with an absorbent cloth.
- Rinse with a clean, damp cloth and wipe dry.

#### CAUTION

- To avoid possible burns do not attempt to operate the surface burners without the burner caps.
- Do not use spray oven cleaner on the cooktop

#### To clean burner heads:

1. Remove the burner cap from the burner head (see Figure 17). Clean the cap with hot soapy water and dry thoroughly.

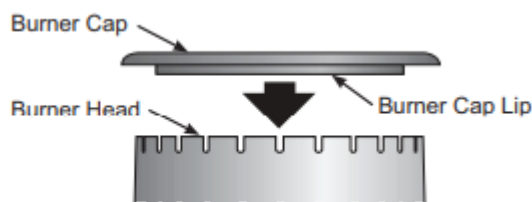

**Figure 17: Burner Cap**

2. For burned-on and dried spills, apply hot soapy water to the burner head. Allow time for the soils to soften

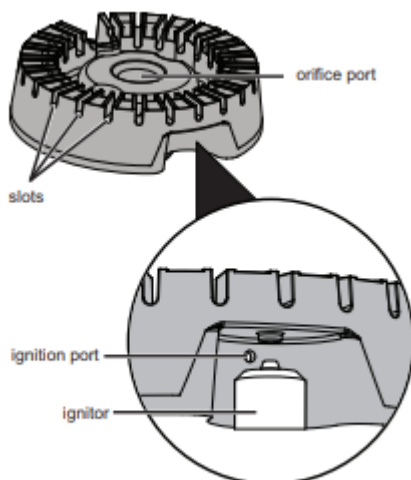

**Figure 18: Sealed burner components**

3. Use a toothbrush to clean all over the burner head (see Figure 18).

4. Use the toothbrush to clean the slots and holes in the burner (see Figure 18).
5. Use a needle or fine wire to clean out the ignition port (see Figure 18).
6. Wipe the burner head clean with a soft, clean cloth, sponge, or scratch-free cleaning pad.
7. Before using the cooktop again, make sure the burner caps are properly placed and seated on the burner heads. When placed correctly, the burner cap is centered on the burner head and will click into place on the burner head. You can wiggle the cap to test placement, it should not move off the burner head (see “Assembly of the burner caps” on page 13).

Important notes:

- The surface burner heads are secured to the cooktop and must be cleaned in place on the cooktop.
- Always keep the surface burner caps in place whenever a surface burner is in use.
- When replacing the burner caps, be sure the burner caps are seated firmly on top of the burner heads.

For proper flow of gas and ignition of burners do not allow spills, food, cleaning agents, or any other material to enter the gas orifice port opening.

CAUTION: Be sure the oven is unplugged and all parts are cool before replacing the oven light.

### **Remove and replace storage drawer (some models)**

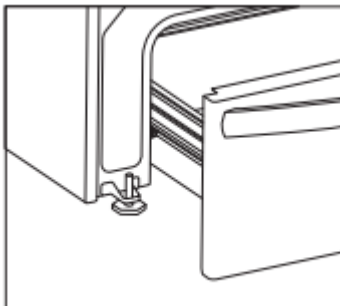
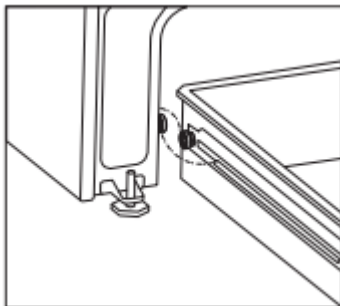

## Replacing the oven interior light bulb

The interior oven light is located at the rear of the oven cavity and covered with a glass shield. The glass shield must be in place whenever the oven is in use (Figure 19).

1. Turn electrical power off at the main source or unplug the appliance.
2. Remove the interior oven light shield after removing the wire holder by carefully moving the wire to the side of the glass shield. The tension from the wire holds the glass shield in place.
3. Pull the shield straight out. Do not twist or turn.
4. Replace the bulb with a new appliance bulb.
5. Replace the glass oven light shield. Replace wire holder.
6. Turn the power back on again at the main source (or plug the appliance back in).
7. Be sure to reset the time of day on the clock.

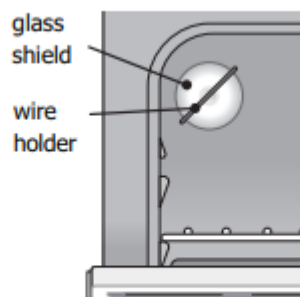

**Figure 19: Oven light protected by glass shield**

## Removing and Replacing the Oven Door

### To remove oven door:

**CAUTION:** The door is heavy. For safe, temporary storage, lay the door flat with the inside of the door facing down.

1. Open oven door completely, horizontal with floor (See Figure 20).
2. Pull the door hinge locks on both left and right door hinges down from the oven frame completely towards the oven door (See Figure 21). A tool such as a small flat-blade screwdriver may be required.
3. Firmly grasp both sides of oven door along the door sides. Do not use the oven door handle (See Figure 22)
4. Close the door to approximately 10 degrees from the door frame (See Figure 22).
5. Lift the oven door hinge arms over the roller pins located on each side of the oven frame (See Figure 23).

### To replace oven door:

1. Firmly grasp both sides of oven door along the door sides. Do not use the oven door handle (See Figure 22). 2. Holding the oven door at the same angle as the removal position, seat the hook of the hinge arm over the roller pins located on each side of the oven door frame (See Figure 22 and Figure 23). The hook of the hinge arms must be fully seated onto the roller pins.
2. Fully open the oven door, horizontal with floor (See Figure 20).
3. Push the door hinge locks up towards and into the oven frame on both left and right oven door hinges to the locked position (See Figure 21).
4. Close the oven door.

**IMPORTANT:** Special door care instructions - Most oven doors contain glass that can break. Do not hit the glass with pots, pans, or any other object. Scratching, hitting, jarring, or stressing the glass may weaken its structure, causing an increased risk of breakage at a later time. Do not close the oven door until all of the oven racks are fully in place.

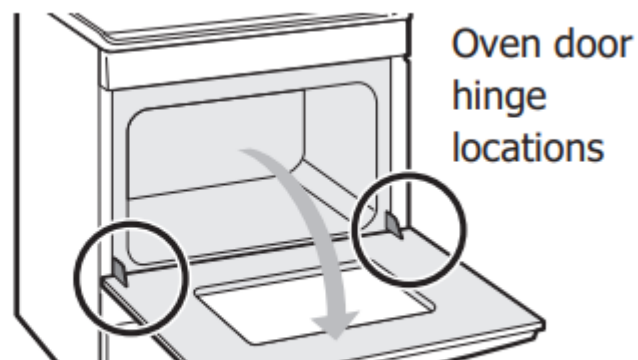

**Figure 20: Door hinge location**

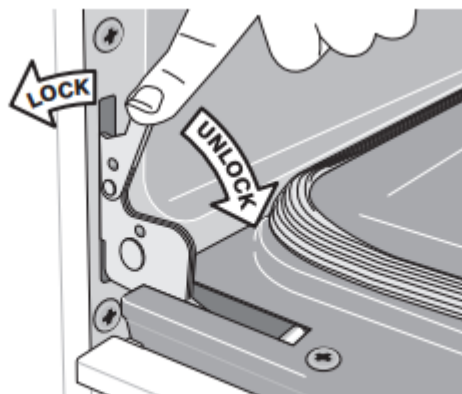

**Figure 21: Door hinge locks**

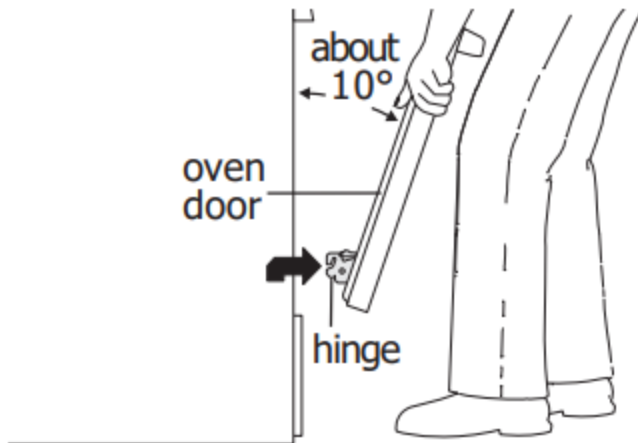

**Figure 22: Holding door for removal**

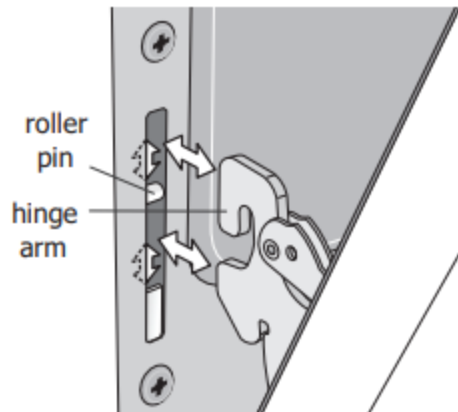

**Figure 23: Replacement and location of hinge arm and roller pin**

## Troubleshooting

BEFORE YOU CALL

### Oven Baking

For best cooking results, preheat the oven before baking cookies, breads, cakes, pies, pastries, etc. There is no need to preheat the oven for roasting meat or baking casseroles. The cooking times and temperatures needed to bake a product may vary slightly from your previously owned appliance.

## Baking Problems and Solutions

| Baking Problems                          | Causes   | Corrections  |
|--|--|--|
| Cookies and biscuits burn on the bottom. | <ul style="list-style-type: none"> <li>• Cookies and biscuits put into oven before oven is preheated.</li> <li>• Oven rack is overcrowded.</li> <li>• Dark pan absorbs heat too fast.</li> </ul> | <ul style="list-style-type: none"> <li>• Allow oven to preheat to desired temperature before placing food in oven.</li> <li>• Choose pan sizes that will permit at least 2" of air space (5.1 cm) on all sides when placed in the oven.</li> <li>• Use a medium weight shiny baking sheet.</li> </ul>  |
| Cakes too dark on top or bottom          | <ul style="list-style-type: none"> <li>• Cakes put in oven before oven is preheated.</li> <li>• Rack position too high or too low.</li> <li>• Oven too hot.</li> </ul>                           | <ul style="list-style-type: none"> <li>• Allow oven to preheat to the selected temperature before placing food in the oven.</li> <li>• Use proper rack position for baking needs.</li> <li>• Set oven temperature 25°F (13°C) lower than recommended.</li> </ul>   |
| Cakes not done in center                 | <ul style="list-style-type: none"> <li>• Oven too hot.</li> <li>• Incorrect pan size.</li> <li>• Pan not centered in oven.</li> <li>• Glass cookware slow heat conductor.</li> </ul>             | <ul style="list-style-type: none"> <li>• Set oven temperature 25°F (13°C) lower than recommended.</li> <li>• Use pan size suggested in recipe.</li> <li>• Use proper rack position and place pan so there are at least 2" (5.1 cm) of space on all sides of pan.</li> <li>• Reduce temperature and increase cook time or use shiny bakeware.</li> </ul>  |
| Cakes not level.                         | <ul style="list-style-type: none"> <li>• Oven not level.</li> <li>• Pan too close to oven wall or rack overcrowded.</li> <li>• Pan warped.</li> <li>• Oven light left on while baking</li> </ul> | <ul style="list-style-type: none"> <li>• Place a marked glass measuring cup filled with water on the center of the oven rack. If the water level is uneven, refer to the installation instructions for leveling the oven.</li> <li>• Use proper rack position and place pan so there are at least 2" (5.1 cm) of space on all sides of pan.</li> <li>• Do not use pans that are dented or warped.</li> </ul> |

|  |   |   |
|--|---|---|
|  |   | <ul style="list-style-type: none"> <li>• Do not leave the oven light on while baking.</li> </ul>  |
| <p>Foods not done when cooking time is over.</p> | <ul style="list-style-type: none"> <li>• Oven too cool.</li> <li>• Oven overcrowded.</li> <li>• Oven door opened too frequently.</li> </ul> | <ul style="list-style-type: none"> <li>• Set oven temperature 25°F (13°C) higher than suggested and bake for the recommended time.</li> <li>• Be sure to remove all pans from the oven except the ones to be used for baking.</li> <li>• Open oven door only after the shortest recommended baking time.</li> </ul> |

**Solutions to Common Problems:**

Before you call for service, review the following list. It may save you time and expense. Possible solutions are provided with the problem listed.



| Problem                            | Cause / Solution   |
|------------------------------------|--|
| Entire appliance does not operate. | <p>Appliance not connected. Make sure power cord is plugged properly into outlet. Check your fuse box or breaker box to make sure the circuit is active.</p> <p>Electrical power outage. Check house lights to be sure. Call your local electrical company for service outage information.</p> |

### Oven Problems

|  |   |
|--|---|
| Poor baking results.   | <p>Many factors affect baking results. Use proper oven rack position. Center the oven and space pans to allow air to circulate. Preheat the oven to the temperature before placing food in the oven. Try adjusting the recommended temperature or baking time. See <a href="#">“Adjusting the oven temperature”</a> on <a href="#">page 28</a> if you feel the oven is too hot or too cool.</p>   |
| Flames inside oven or smoking from oven vent.                | <p>Excessive spills in oven. Grease or food spilled onto the oven bottom or oven cavity. Wipe up excessive spills before starting the oven. If flames or excessive smoke are present when using broil, see <a href="#">“Setting Broil”</a> on <a href="#">page 24</a>.</p>  |
| Oven smokes excessively when broiling.                       | <p>Incorrect setting. Follow the <a href="#">“Setting Broil”</a> instructions on <a href="#">page 24</a>.</p> <p>Meat too close to the broil element or burner. Reposition the broil pan to provide proper clearance between the meat and broil element or burner. Remove excess fat from meat. Cut remaining fatty edges to prevent curling, but do not cut too lean.</p> <p>Grease build up on oven surfaces. Regular cleaning is necessary when broiling frequently. Grease or food splatters will cause excessive smoking.</p>                          |
| Oven control panel beeps and displays any F or E code error. | <p>Oven control has detected a fault or error condition. To clear the error, press the <b>OFF</b> key on the control panel. Once the error code is cleared, try the bake or broil function. If the F or E code error repeats, turn off the power to the appliance for 5 minutes, and then repower the appliance. Set the clock with correct time. Try the bake or broil function again. If the fault recurs, press the <b>OFF</b> key to clear the error.</p>   |
| Oven portion of appliance does not operate.                  | <p>Be sure the regulator gas valve is turned to ON. See installation instructions for details. The time of day is not set. The clock must be set in order to operate the oven. See <a href="#">“Setting the Clock”</a> on <a href="#">page 20</a>.</p> <p>Be sure the oven controls are set properly for the desired function. See <a href="#">“Control Features”</a> starting on <a href="#">page 19</a> and review instructions for the desired cooking function in this manual or see <a href="#">“Entire appliance does not operate”</a> checklist.</p> |



## Cooktop Problems

Surface element is too hot or not hot enough.      Incorrect surface control setting. Adjust power level setting.

|                                       |   |
|---------------------------------------|---|
| <p>Surface burners do not ignite.</p> | <p>Surface control knob was not completely turned to LITE (  ). Push in and turn the surface control knob to LITE until the burner ignites and then turn the control knob to the desired flame size.</p> <p>Burner ports are clogged. With the burner OFF and cool, use a small-gauge wire or needle to clean the burner head slots and ignition ports. See “Cleaning the sealed burners” in the Care &amp; Cleaning section on page 31 for additional cleaning instructions.</p> <p>Range power cord is disconnected from outlet (electric ignition models only). Ensure the power cord is securely plugged into the power outlet.</p> <p>Circuit is broken. Check breaker box or fuse box.</p> <p>Electrical power outage. Burners may be lit manually. See “Setting Surface Controls” on page 16.</p> |
|---------------------------------------|---|

Surface burner flame is too high.      Surface control knob is set too high. Adjust to a lower flame setting.

   Burner caps are not seated properly. Check that all surface burner caps are seated and seated correctly on the surface burner heads. See “[Cleaning the burners](#)” in the Care & Cleaning section on [page 31](#) for additional instructions.

   Incorrect L.P. conversion. Refer to L.P. conversion kit instructions to correct.

Surface burner flame is orange.      Dust particles in main gas line. Allow the burner to operate a few minutes until the flame turns blue. In coastal areas, a slightly orange flame is unavoidable due to salt content in the air.

   Incorrect L.P. conversion. Refer to L.P. conversion kit instructions to correct.

## Self Clean Problems

Self clean does not work.      Oven control not set properly. See “[Self Clean](#)” on [page 26](#).

Oven racks discolored or do not slide easily.      Oven racks left in oven cavity during self clean. Remove oven racks from oven cavity before starting a self-clean cycle. Clean by using a mild abrasive cleaner following manufacturer's instructions. Rinse with clean water, dry, and replace oven racks.



---

Soil not completely removed after self clean. Review instructions on ["Self Clean"](#) on [page 26](#) self clean.

Excessive spills on oven bottom. Remove excessive spills before starting self clean.

Failure to clean soil from the oven frame, the door liner outside the oven door gasket, and the small area at the front center of the oven bottom. These areas are not in the self-cleaning area, but get hot enough to burn on residue. Clean these areas before starting the self-cleaning cycle. Burned-on residue can be cleaned with a stiff nylon brush and water or a nylon scrubber. Be careful not to damage the oven gasket.

---

The oven control display shows "SCC" and self-clean is not working.

If the cooktop is used during a self-clean cycle, the oven may turn off. The control display will show "SCC" for 5 seconds. The oven door will remain locked until the oven has cooled down below cleaning temperature. If the oven is above cleaning temperature, the user can start another clean cycle immediately. If the oven is in cleaning temperature range, another self-clean cycle can be set. The oven door unlocks (up to 4 hours).

---

### Other Problems

---

Appliance is not level.

Be sure the floor is level, strong, and stable enough to adequately support the appliance weight.

If the floor is sagging or sloping, contact a carpenter to correct the situation.

Poor installation. Place the oven rack in the center of the oven. Place a leveling oven rack. Adjust the leveling legs at the base of the appliance until the appliance is level.

Kitchen cabinet alignment may make range appear not level. Be sure cabinets are square and have sufficient room for appliance clearance.

---

Cannot move appliance easily. Cabinets not square or are built in too tightly. Contact the builder or installer. Appliance must be accessible for service.

Carpet interferes with appliance. Provide sufficient space so the appliance can be lifted over carpet. Installation over carpet is not advised. See the installation instructions for guidelines specific to your appliance.

---

Oven light does not work.

Be sure the oven light is secure in the socket. See ["Replacing the oven interior bulb"](#) on [page 32](#).

---

### Warning

This content is compiled from multiple sources and is provided for reference purposes only. It may not be complete or fully applicable to all situations. If you are unable to resolve your issue, please contact the product manufacturer or an authorized service provider for official support.

---

Document generated by [ManualsFile](#)

