

## Use And Care Guide for Induction Cooktop

### Cooktop Features

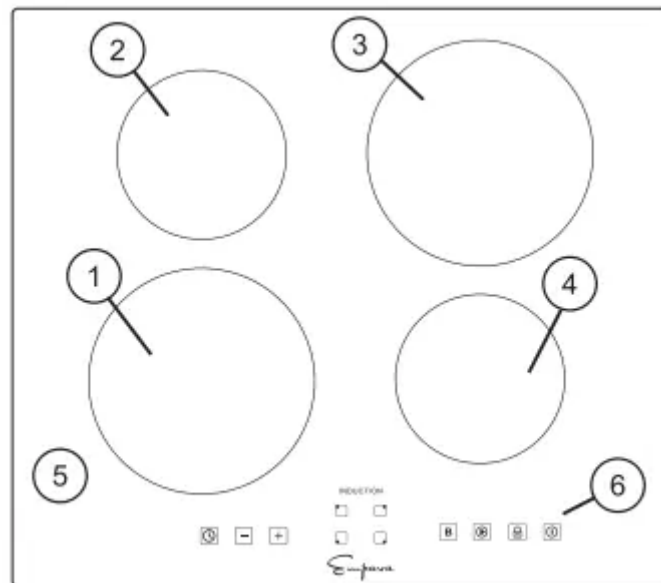

1. Front left cooking element control area
2. Rear left cooking element control area
3. Rear right cooking element control area
4. Front right cooking element control area
5. Ceramic glass
6. Touch control panel

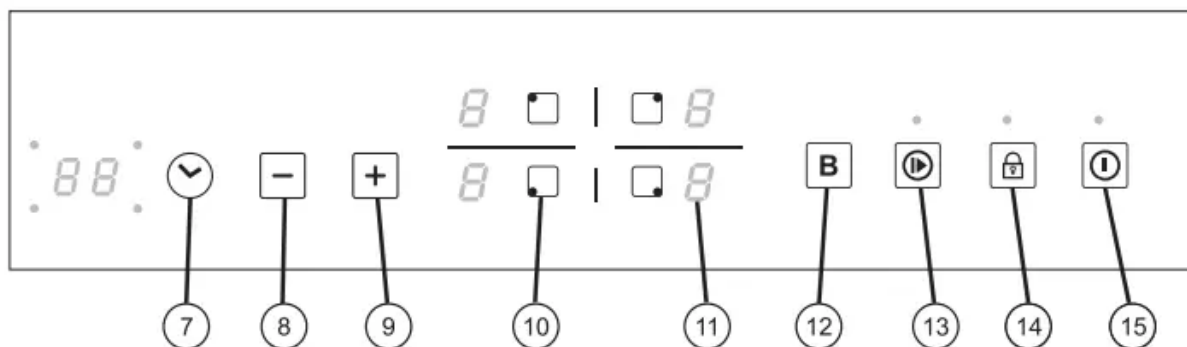

7. Minuter timer
8. Decrease power or time
9. Increase power or time
10. Cooking element symbol and Power ON
11. Power level and residual heat display

12. Power boost
13. Stop/Go
14. Controls Lock
15. Main Power on/off

## Heat Setting Displays

DISPLAY	DESCRIPTION
-	No power level for the element
L	The keep warm function
1-9	The power level
P	The power boost
H	A cooking element is still hot to touch (residual heat)
E	Electronics fault error message of specific cooking element
E0-E9	Error code
0	STOP/GO

## Using The Cooktop

This manual covers different models. The cooktop you have purchased may have some or all of the features listed.

### Controls Lock

- Controls Lock is activated when the cooktop is off: Controls Lock prevents activation of any sensor key, except for the Lock key pad, so you must deactivate the control lock firstly, then touch the main POWER key pad to turn on the cooktop.
- Controls Lock is activated during the cooktop use: Controls Lock prevents activation of any sensor key, except for the ON/OFF, Power and Lock key pad.

### To Lock

Touch and Hold Lock key pad for 3 seconds, a “beep” will sound and the indicator light above the Lock key pad will be lit up.

### To unlock

Touch and Hold Lock key pad for 3 seconds, a beep will sound, the indicator light will turn OFF.



### IMPORTANT

Touch and hold for 3 seconds

## To Turn On The Cooktop

While in the Standby mode, touch the Main “Power” key pad, a “beep” will sound and the indicator light above the Power key pad will be lit up, indicating that the induction cooktop functions are ready to use. The unit will automatically return to Standby mode if no ON/OFF keys are touched within 30 seconds.



## Operating The Cooking Elements

To turn on one or more Cooking Elements, place a compatible pot or pan on the desired cooking element. With the cooktop being ON as mentioned above, touch the “ON” key pad of the desired cooking element, the Power display will show a “ ”, indicating no power level for the Element has been set yet, then press either the “+” key, key or “B” (Power Boost) key to select a cooking level. The selected cooking element will automatically turn off if no power selection key is not pressed within 30 seconds.

Touch the Minus key (-) to start at low level, the power display will show 1.

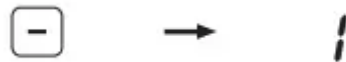

Touch the Plus key (+) to start at high level, the power display will show 9.

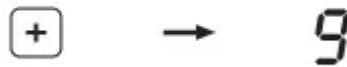

Touch the “B” key, it will show on the display as a “P” and Power Boost LED is lit up, boosting the heating power to the highest level for 10 minutes.



## Power Management

Touch “ ” key or “+” key to adjust the desired power level;

**NOTE:** During cooking, the unit is equipped with safeguards against parching.

**NOTE:** Heating will appear intermittent phenomenon when cooking element is used for frying, stir-frying, grilling and other high temperature cooking formats.

### Automatic Power Level Control

The power level displayed may be different from the actual power level at the power sharing and high temperature range. To prevent the cooktop from overheating, the power level is controlled automatically.

### Power Boost

Touch "+" key to level 9, then press once to enter into Boost mode, the power display will show a "P". The 'Boost' function is used to cook at maximum power for a short period of time (maximum 10 minutes). The power is reduced to level 9 at the end of the maximum boost time.

In the Boost status, touch "-" key or after 10 minutes the power boost setting will switch off automatically, Power digital will switch from P to 9.

**WARNING** Power Boost is only recommended for BOILING WATER.

**WARNING** DO not leave a pot unattended while in Boost Mode or other high power settings.

### Keep Warm

While in the Power level 1, touch "-" key to enter into Keep Warm mode, Power digital will switch from 1 to L.

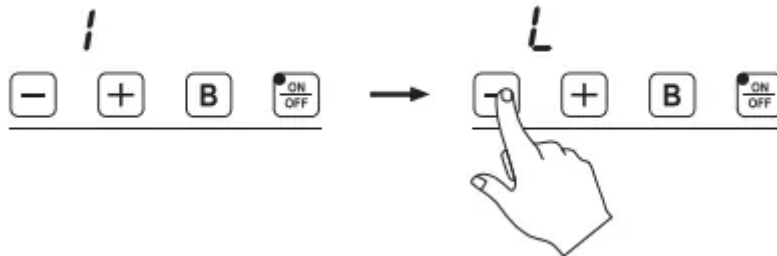

### Power Sharing

Four or five cooktops are divided into two separate cooking area, the right and left side cooking elements share power of a inverter.

Power sharing is activated when the cooking element in the same area are activated; the controls adjust the power automatically for "Power Sharing". This power sharing is administered by unit's microprocessors, which will alternate power in one area.



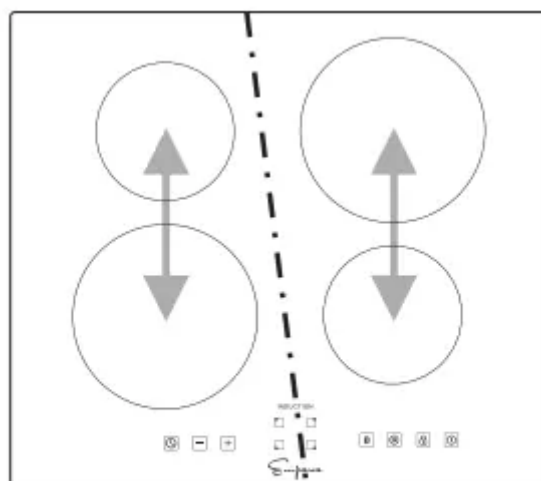

Left Zone

Right Zone

**Power sharing tips:** Remember to select the power setting last for the cooking element you want to maintain at full setting heat. To maintain full setting heat for two items, place one item on a element in one section (left side), and the other item on a element in another section (right side).

### Residual Heat Indicator



After using any of the Cooking Element, the cooking area will remain hot. Even after turning off the entire unit, the surface of the cooktop will remain hot for some time. The digital display for the Cooking Element will show an “H” to warn the user that the surface is hot to touch (Hot surface indicator) after the Cooking Element switch off. Wait until the “H” is no longer displayed to clean the unit. You may turn the Cooking Element back on even if the “H” is displayed.

### Stop/Go

#### ONLY FOR 24"MODEL EMPV-IDC24 AND 30"MODEL EMPV-IDC30

Use the Stop/Go function to 'Pause' the cooktop for Max. 10 minutes while cooking; the unit will be automatically switched off if Stop/Go is not touched again within 10 minutes.

#### To turn on

One or more cooking zones are active. Touch Stop/Go key pad, a “beep” will sound, the indicator light above the Stop/Go will be lit up and all opened Power digital display of the cooktop will show blinking like marching ants.

Any set cooking timers/minute stop, When deactivating "Stop and Go", the countdown will continue.

All of the buttons are inactive except for Stop/Go, Lock and ON/OFF and POWER key. If no any key are touched within 10 minutes, all of the active cooking zones are automatically switched off.

### To turn off

Touch Stop/Go key again within 10 minutes, the indicator light above Stop/Go button will go off, and the cooktop continues with the settings that were set before the Stop / Go.

### Set Timer

Use “+” or key to adjust and set the desired time. Ashort key press adjusts the time by 1 minute and a long key press by 10 minutes. The automatic timer settings range from 1 minute to 99 minutes. (NOTE: There is no “seconds” and “hours” display, only minutes.) The red dot next to the Time symbol indicatorwill illuminate indicating that the cooking elements is selected.

While cooking, touch the Timer key pad until time light of the desired cooking element is ON, Time digital display reads “00” and blinking; Touch “+” or ” key to set the desired number, Once the Timer is set and no “+” or ” key are pressed for 5 seconds, the Minute Timer begins the countdown and the timerdisplay will stop blinking and will stay on in the display. Once the Minute Timer reaches “00”, a “beep” will be sound, indicating that the time is up, the Particular Cooking Element will automatically shut off.



If you want to set another burner to switch-off automatically, touch Timer key to until the desired time symbol indicator blinks, repeat the same steps above.

If you want to check the remaining time for another Cooking Element, touch the Timer until the Time symbol indicator for the desired Cooking Element blinks.

If more than one switch-off time is programmed, the shortest time remaining will show in the Time digital display, the indicator for that particular burner will be blinking.

### To Cancel Timer

Touch the Timer until the Time symbol indicator for the desired Cooking Element blinks, then touch the “+” or “- ” to set the timer to 00. The Time digital display will blink for 5 seconds and then turn off, indicating that the timer of selected cooking element has been cancelled.

## Cookware Noise

The induction fields are generated by electronics equipment, which are pretty much silent but they do produce heat at high power level. A soft-sounding cooling fan runs when the unit is running multiple cooking elements at high settings at once or when a cooking element is set at very high power settings.

What can sometimes produce sound with induction cooking is not the induction equipment but the cookware itself. Slight sounds may be produced by different types of cookware. Some of the possible causes include:

- Heavier pans such as enameled cast iron produce less noise than a lighter weight multi-ply stainless steel pan; Light weight cookware may also vibrate. Heavyweight quality cookware is recommended.
- Cookware with irregular or warped bottoms can vibrate audibly on the ceramic glass surface, though again typically only at high power settings.
- A “Cracking” noise may be heard if the cookware base is made of layer of different material.
- A low “humming” noise occurs when cooking, which is normal particularly at high power settings.
- Whistling can occur if both elements are being used at the same time at the high settings, and the cookware has bases made of layer of different material.
- Loose-fitting handles on cookware, typically when riveted on, can vibrate slightly.
- High quality cookware of solid cast iron including enamelware will lower the noise.

## Compatible Cookware

The quality of your cooking is dependent on the cookware you use. Because induction cooking requires a magnetic vessel for heating, only certain materials can be used on your cooktop.

Induction requires pots and pans that are made of ferrous(meaning magnetic) materials.

Check your cookware’s retail box for the induction symbol. To tell if your current cookware is compatible with the induction technology, grab a magnet and see if it holds to the bottom of the cookware. If your magnet stays on then your cookware is ready to be used on the Induction cooktop!

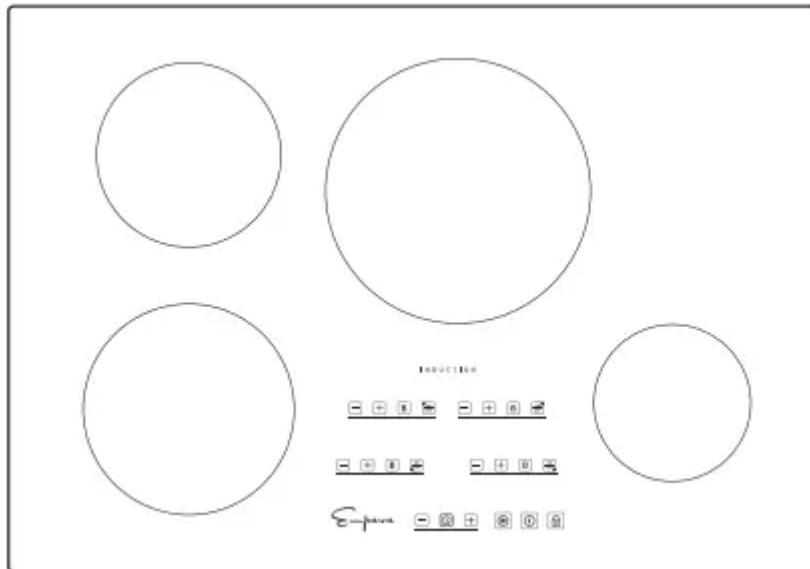

Optimally the cookware will have this induction image on the retail box:

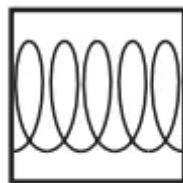

Induction

The following are not compatible: heat-resist glass, ceramic, copper, aluminum pan/pots, round-bottomed cookware, or cookware with a base less than 5 inches.

**NOTE:** Some cookwares can produce noises when used on induction cooking zones. This is not a fault in the cooktop, and its function will not be impaired in any way as a result.

## Cleaning Your Cooktop

Please follow these directions along with Important Safety steps for cleaning, advised at the beginning of the manual. Use a ceramic glass cleaner on the glass cooktop. To maintain and protect the surface of your glass cooktop, follow these steps:

Before using the cooktop for the first time, clean it to protect the top and makes cleanup easier.

- 1. Daily use of ceramic glass cleaner when the cooktop is cool will keep the cooktop looking new.
- 2. Shake the cleaning solution well. Apply a few drops of ceramic glass cleaner directly to the cooktop.
- 3. Use a paper towel or a soft cleaning pad for ceramic surface to clean the entire cooktop surface.

- 4. Use a dry cloth or paper towel to remove all cleaning residue. No need to rinse. Never run the cooktop underwater.

### **Cleaning Burned on Residue:**

**NOTE:** It is very important that you DO NOT use the cooktop until it has been thoroughly cleaned.

**WARNING:** Damage to the glass surface may occur if you use scrub pads or any other type of abrasive cleaning materials.

- 1. Allow the cooktop to cool.
- 2. Spread a few drops of the ceramic glass cleaner on the burned residue area.
- 3. Using the ceramic glass cleaning pad, rub the residue area, applying pressure as needed.
- 4. If any residue remains, repeat the steps listed above.
- 5. For additional protection, after all residue has been removed, polish the entire surface with the ceramic glass cleaner and a paper towel.

### **Cleaning heavy burned - on residue:**

- 1. Allow the cooktop to cool.
- 2. Used a singleedge razor blade scraper approximately at a 45 degree angle against the glass surface, and scrape offtheresidue.
- 3. After scraping off the residue, apply a few drops of the ceramic glass cleaner on the entire burned residue area. Use the cleaning pad to remove any remaining residue.
- 4. For additional protection, after all residue has been removed, polish the entire surface with the ceramic glass cleaner and a paper towel.

### **Metal Marks and Scratches:**

Be careful not to slide pots or pans across the cooktop surface. It will leave behind metal markings. These marks are removable using the ceramic glass cleaner along with the cleaning pad for induction cooktop.

If pots with a thin overlay of aluminum or copper boil dry, the overlay may leave a black discoloration on the cooktop. This should be removed immediately before using the cooktop again or the discoloration will become permanent.

**NOTE:** If cracks or indentations in the glass surface occurs, the cooktop glass will have to be replaced. Contact the manufacturer for assistance.

## **Troubleshooting Guide**

If you encounter the following problems while using your cooktop, check the guide below to see if you can correct the problem yourself before calling for assistance or service:

<ul style="list-style-type: none"> <li>• <b>Cooktop does not work</b></li> </ul>	<ul style="list-style-type: none"> <li>• Cooktop controls are locked</li> <li>• Power outage</li> <li>• Installation wire not complete</li> <li>• Circuit breaker has tripped or fuse is blown</li> </ul>	<ul style="list-style-type: none"> <li>• Make sure Lock mode is turned off</li> <li>• Check house lights to confirm power outage</li> </ul>
<ul style="list-style-type: none"> <li>• <b>Cooktop does not heat</b></li> </ul>	<ul style="list-style-type: none"> <li>• No cookware or improper cookware placement on the cooking element</li> <li>• Incorrect cookware size for the selected cooking element</li> <li>• Cookware is not properly resting on cooking element</li> <li>• Incorrect cooking element selected</li> <li>• No power to cooktop</li> </ul>	<ul style="list-style-type: none"> <li>• Make sure that the cookware is centered on the cooking element, and that cookware is also of correct type for induction cooking. See <b>Compatible Cookware</b></li> <li>• The bottom of the cookware must be large enough to cover cooking element completely. See <b>Compatible Cookware</b></li> <li>• Cookware bottoms must be flat and centered on the cooking element. See <b>Compatible Cookware</b></li> <li>• Make sure the correct control is ON for the cooking element being used</li> <li>• See “Cooktop does not work” above</li> </ul>
<ul style="list-style-type: none"> <li>• <b>Cooktop turns off while cooking</b></li> </ul>	<ul style="list-style-type: none"> <li>• Cooktop internal heat sensor has detected high temperature inside the cooktop, activating automatic shut off</li> <li>• Liquid or object on the controls area</li> </ul>	<ul style="list-style-type: none"> <li>• Make sure the cooktop vents are not blocked</li> <li>• The cooktop features an automatic shutoff feature that turns off the entire cooktop if any cooking element has been on continuously for 2 hours</li> <li>• The cooktop control panel may register liquids or objects obstructing the panel, which can cause the cooktop to shut off. Clean up spills or remove objects and restart the unit</li> </ul>
<ul style="list-style-type: none"> <li>• <b>Power boost does not work</b></li> </ul>	<ul style="list-style-type: none"> <li>• Boost function is not available if adjacent</li> </ul>	<ul style="list-style-type: none"> <li>• See <b>Power Sharing</b></li> </ul>



	burner is in use and total power reach 3700W or 4800W (right zone or left *zone)	
<ul style="list-style-type: none"> <li>• <b>The fans keep running for one minute after the cooking element has been switched off</b></li> </ul>	<ul style="list-style-type: none"> <li>• The electronics are cooling down</li> </ul>	<ul style="list-style-type: none"> <li>• This is a normal occurrence</li> </ul>
<ul style="list-style-type: none"> <li>• <b>“E” appears in the Power display</b></li> </ul>	<ul style="list-style-type: none"> <li>• Electronics fault error message of particular cooking element</li> </ul>	<ul style="list-style-type: none"> <li>• See E0, E1, E2, E3, E7, E8, E9, EE</li> </ul>
<ul style="list-style-type: none"> <li>• <b>“E0” appears in the Timer display</b></li> </ul>	<ul style="list-style-type: none"> <li>• IGBT overheating</li> </ul>	<ul style="list-style-type: none"> <li>• Turn off unit to allow IGBT to cool. Restart unit</li> </ul>
<ul style="list-style-type: none"> <li>• <b>“E1” appears in the Timer display</b></li> </ul>	<ul style="list-style-type: none"> <li>• No cookware found or improper placement of cookware on the cooking element</li> </ul>	<ul style="list-style-type: none"> <li>• Make sure that the cookware is centered on the cooking element, and that it is also induction compatible. See <b>Compatible Cookware</b></li> </ul>
<ul style="list-style-type: none"> <li>• <b>“E2” appears in the Timer display</b></li> </ul>	<ul style="list-style-type: none"> <li>• Supplied voltage to cooktop is too low</li> </ul>	<ul style="list-style-type: none"> <li>• This may be caused by reduced voltage being supplied to the house circuit. If connections are correct and the supplied voltage returns to normal, the code will disappear</li> </ul>
<ul style="list-style-type: none"> <li>• <b>“E3” appears in the Timer display</b></li> </ul>	<ul style="list-style-type: none"> <li>• Supplied voltage to cooktop is too high</li> </ul>	<ul style="list-style-type: none"> <li>• This may be caused by increased voltage being supplied to the house circuit. If the connections are correct and the supplied voltage returns to normal, the code will disappear</li> </ul>

• “E7” appears in the Timer display	• NTC1 Break off	•Turn the cooktop OFF; then pull plug out for about 30 seconds. Then re-insert the plug and turn the cooktop on using the POWER pad. If the error message is still displayed, call for service
• “E8” appears in the Timer display	• NTC1 Short circuit	
• “E9” appears in the Timer display	• NTC2 Break off	
• “EE” appears in the Timer display	• NTC2 Short circuit	
• Noise	• Noise like humming, crackling and buzzing	•This is a normal occurrence, See <b>Operational Cooktop Noises</b>

## Installation Instructions

### IMPORTANT SAFETY INFORMATION

**WARNING** Installation and service must be performed by a qualified installer or service technician.

Read and save these instructions for future reference.

**DANGER** Always read and obey all safety information, failure to follow these instructions can be killed or seriously injured.

### Before Installing the cooktop

- 1. Visually inspect the cooktop for damage. Also make sure all cooktop screws are on tight.
- 2. Record the model and serial number as found on the bottom of your cooktop. When ordering parts for or making inquires about your cooktop, always be sure to include the model and serial numbers and a lot number or letter from the serial plate On your cooktop.
- 3. Cutout dimensions of the countertop.
- 4. Make sure the wall coverings, countertop and cabinets around the cooktop can withstand heat (up to 200°F) generated by the cooktop.
- 5. Gently lower the cooktop into the countertop cutout.



**NOTE:** Do not seal the cooktop to the countertop, the cooktop must be removable if service is necessary.

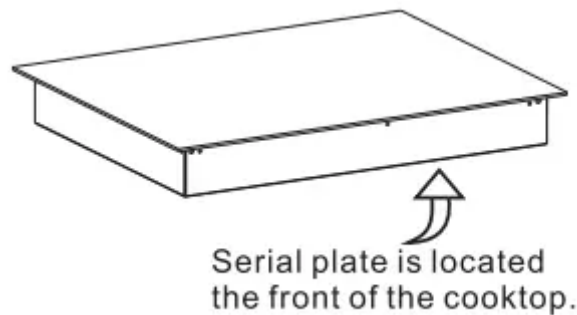

## Electrical Connection

**IMPORTANT** Observe all governing codes and local ordinances.

Model EMPV-IDC24 needs 40 Amp service.

Model EMPV-IDC30 needs 40 Amp service.

Model EMPV-IDC36 needs 50 Amp service.

### Maximum Connected Load

Model EMPV-IDC24.....7.4 kW at 240 VAC, 6.4 kW at 208 VAC

Model EMPV-IDC30.....7.4 kW at 240 VAC, 6.4 kW at 208 VAC

Model EMPV-IDC36.....9.6 kW at 240 VAC, 8.3 kW at 208 VAC

The Induction Cooktops must connect to a separate, grounded wire, single phase, AC Only electrical supply with their own circuit breaker. These appliances must be installed in accordance with National Electrical Codes, as well as all state, municipal and local codes. This appliance must be supplied with the proper voltage and frequency and amperage, which is protected by a properly sized circuit breaker or time delay fuse.

The cable from appliance is equipped with 3-wires:

### If 3-Wire Cable from Home Power Supply

**IMPORTANT:** Use the 3-wire cable from Home Power Supply where local codes permit a 3-wire connection.

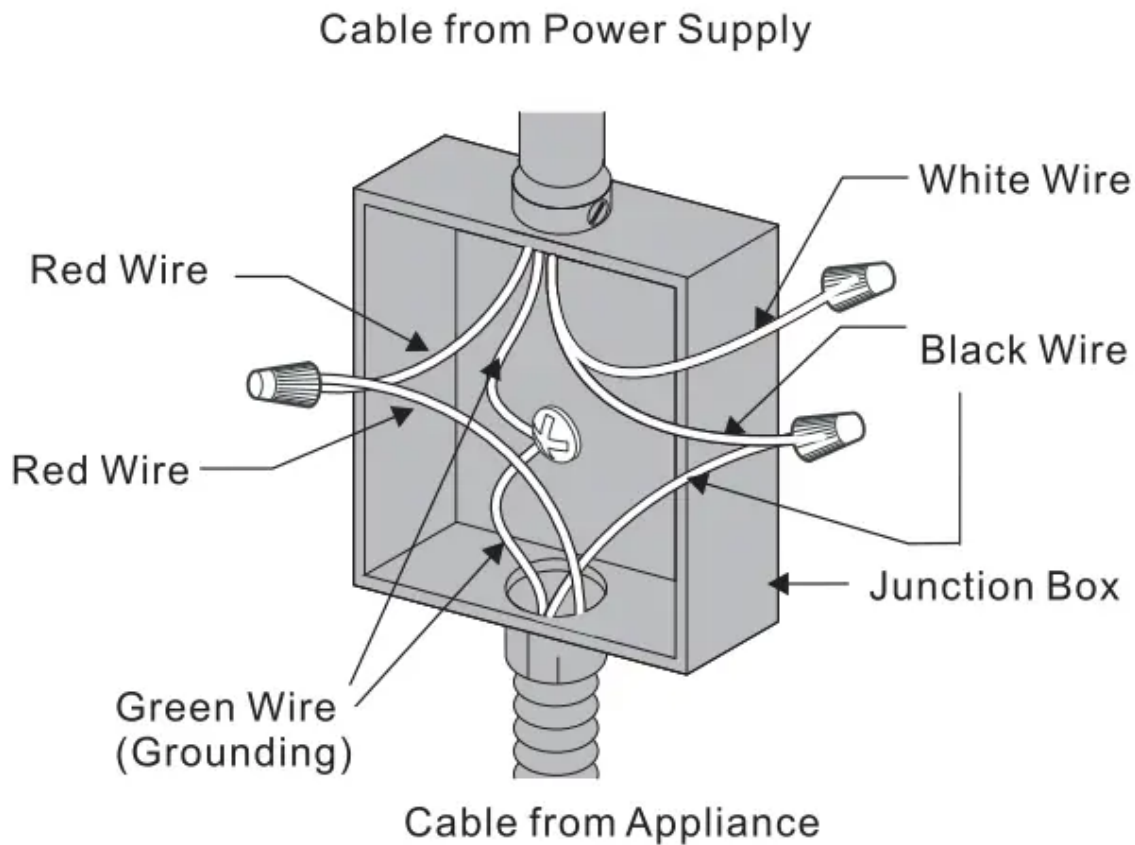

**3-Wire Cable from Home Power Supply**

**If 4-Wire Cable from Home Power Supply**

**IMPORTANT:** Use the 4-wire cable from Home Power Supply where local codes do not allow grounding through neutral.

**4-Wire Cable from Home Power Supply**

**Electrical ground is required on this appliance**

**WARNING** The cooktop conduit wiring is approved for copper wire connection only, if you have aluminum house wiring, use only special connectors which are approved for joining copper and aluminum wires conform with local codes and ordinances. Follow the electrical connector manufacturer's recommended procedure closely.

**Installation — 24" (59cm) Model EMPV-IDC24**

<b>Cooktop Dimensions</b>		
A. Width	B. Depth	C. Height
23 <sup>7</sup> / <sub>32</sub> " (590)	20 <sup>15</sup> / <sub>32</sub> " (520)	2 <sup>1</sup> / <sub>8</sub> " (55)



\* DO NOT obstruct these areas.

**IMPORTANT:** For perfect ventilation, provide a vent of under the countertop, in the front of the cabinet and in the back of the cabinet. The ventilation opening is to extend the full length of the cooktop cutout.

### EMPV-IDC24 Cooktop and Cutout Dimension

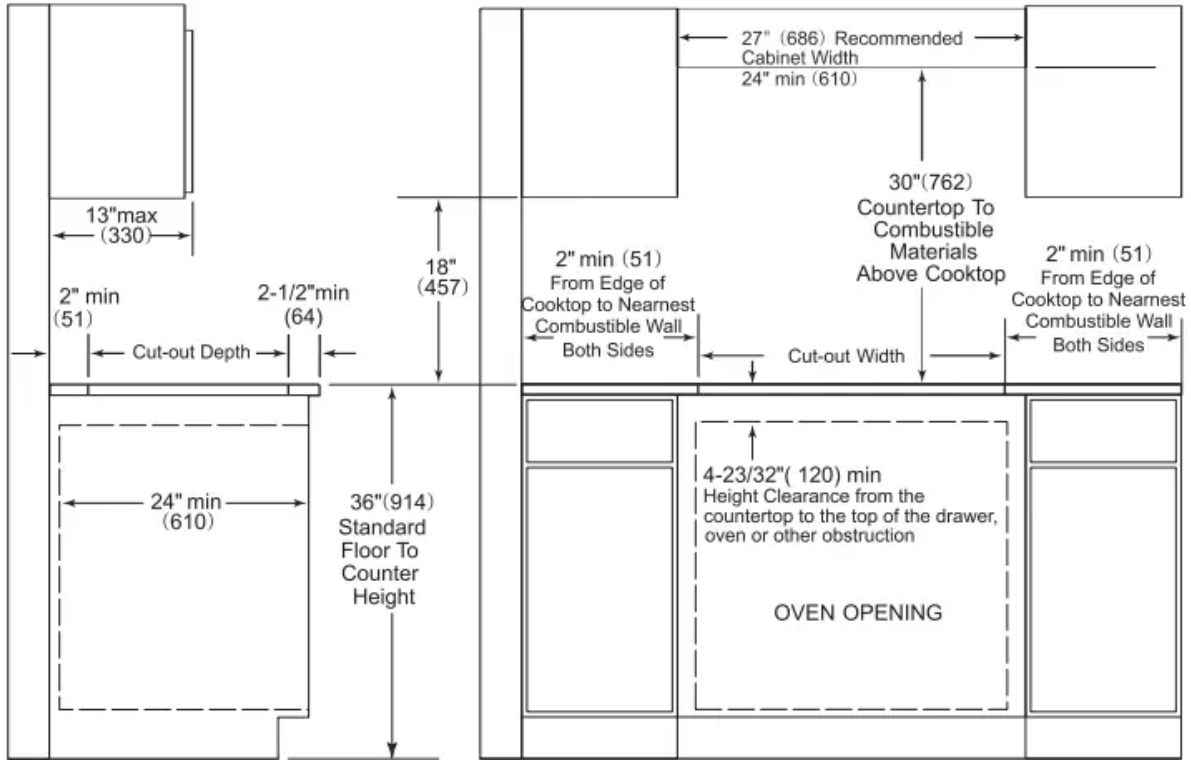

### EMPV-IDC24 Countertop Cut-Out Opening

All dimensions are stated in inches and (mm).



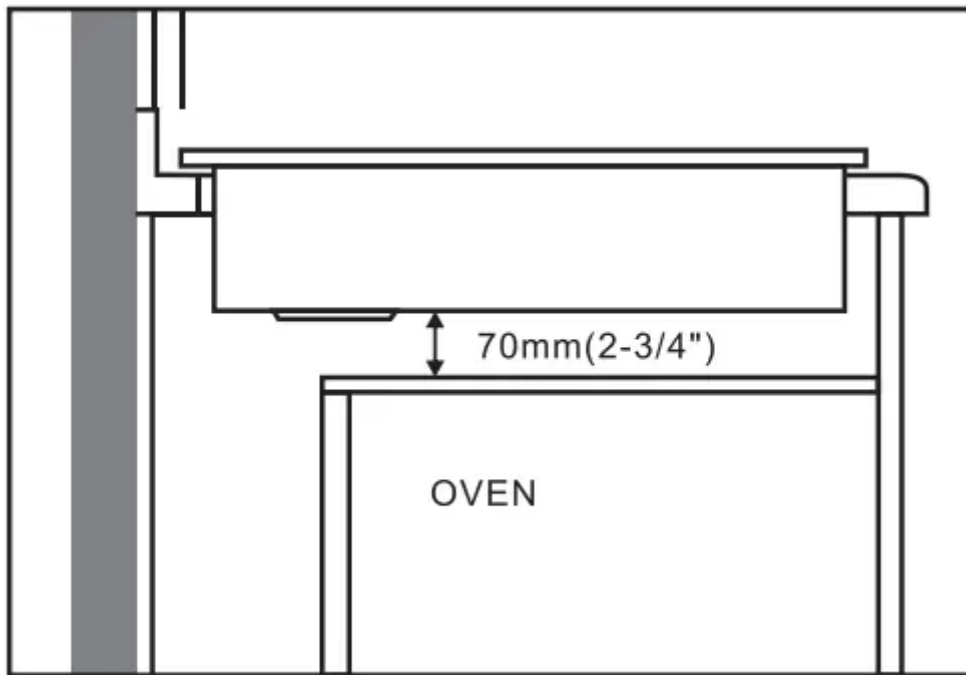

**CAUTION** It is very important to keep 2\*A" (70mm) distance between the cooktop and the oven.

**Note:**do not put a divider between the oven and cooktop

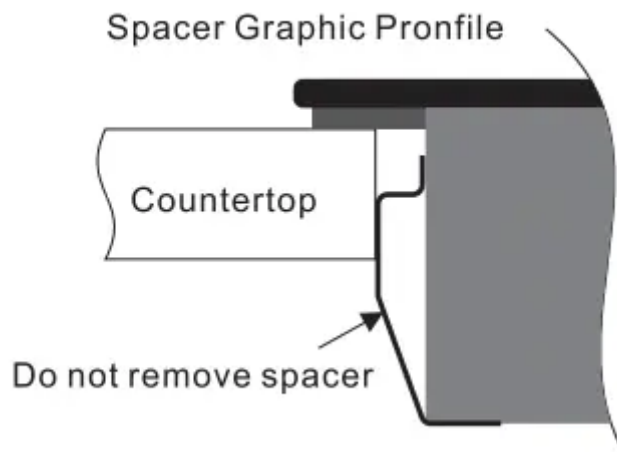

**NOTE:**The cooktops include spacers on both sides to ensure proper airflow once installed.Do not remove the spacers.

### After Installation

- 1. Remove all the stickers and items from the top of the cooktop surface.
- 2. Clean cooktop before use. Dry with a soft cloth. See Cleaning Your Cooktop for reference.
- 3. Read Using The Cooktop.
- 4. Turn on the power to the cooktop.
- 5. Verify all function operation properly.

**NOTE:** If the cooktop does not work, or you met any problem in your operation, please check that the circuit breaker has not tripped or the house has not blown. For more information, please See Troubleshooting Guide. If you do not solve the problem by yourself, please call us for assistance or service.

**Warning**

This content is compiled from multiple sources and is provided for reference purposes only. It may not be complete or fully applicable to all situations. If you are unable to resolve your issue, please contact the product manufacturer or an authorized service provider for official support.

---

Document generated by [ManualsFile](#)

