

Use & Care Guide for Refrigerator

Temperature Controls

Dial Temperature Controls (select models)

The controls are located at the back left of the refrigerator compartment.

Note: The Freezer control turns the cooling system on. Neither section will cool if freezer control is set to OFF.

Initial Control Settings

After plugging the refrigerator in, set the controls.

- To adjust the controls, turn the control knob to the left or right as desired.
- Set the Freezer control on 4.
- Set the Refrigerator control on 4.
- Let the refrigerator run at least 8 to 12 hours before adding food.

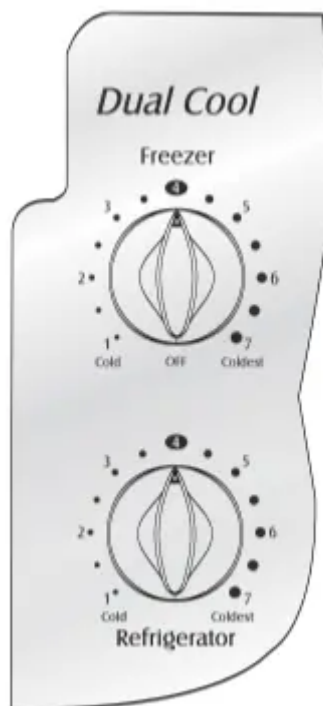

Warm Cabinet Surfaces

At times, the front of the refrigerator cabinet may be warm to the touch. This is a normal occurrence that helps prevent moisture from condensing on the cabinet. This condition will be more noticeable when you first start the refrigerator, during hot weather and after excessive or lengthy door openings.

Adjusting the Controls

- 24 hours after adding food, you may decide that one or both compartments should be colder or warmer. If so, adjust the control(s) as indicated in the Temperature Control Guide table. See page 22 for instructions on checking compartment temperature.
- Except when starting the refrigerator, do not change either control more than one number at a time.
- Allow 24 hours for temperatures to stabilize.
- Changing either control will have some effect on the temperature of the other compartment.

Temperature Control Guide

Refrigerator too warm	Turn the Refrigerator control to next higher number.
Refrigerator too cold	Turn the Refrigerator control to next lower number.
Freezer too warm	Turn the Freezer control to next higher number.
Freezer too cold	Turn the Freezer control to next lower number.
Turn refrigerator OFF	Turn the Freezer control to OFF.

Note: Turning Freezer control to OFF stops cooling in both compartments. It does not shut off power to the refrigerator.

Touch Temperature Controls

(select models, style varies by model)



The controls are located at the top front of the refrigerator compartment.

Control



Initial Control Settings

After plugging the refrigerator in, set the controls.

- Pressing the  or  pads adjusts the controls to the desired setting.
- Set the Freezer control on 4.

- Set the Refrigerator control on 4.
- Let the refrigerator run at least 8 to 12 hours before adding food.





Warm Cabinet Surfaces

At times, the front of the refrigerator cabinet may be warm to the touch. This is a normal occurrence that helps prevent moisture from condensing on the cabinet. This condition will be more noticeable when you first start the refrigerator, during hot weather and after excessive or lengthy door openings.

Adjusting the Controls

- 24 hours after adding food, you may decide that one or both compartments should be colder or warmer. If so, adjust the control(s) as indicated in the Temperature Control Guide, page 9.
- Except when starting the refrigerator, do not change either control more than one number at a time.
- Allow 24 hours for temperatures to stabilize.

Temperature Control Guide

Refrigerator too warm	Set the Refrigerator control to next higher number by pressing the  pad.
Refrigerator too cold	Set the Refrigerator control to next lower number by pressing the  pad.
Freezer too warm	Set the Freezer control to next higher number by pressing the  pad.
Freezer too cold	Set the Freezer control to next lower number by pressing the  pad.
Turn refrigerator OFF	Press the Freezer or Refrigerator  pad until a dash “—” appears in the display.

Triple Cool Climate Control

(select models)

The control is located at the top front of the fresh food compartment.



Control





Initial Temperature Setting







Temperatures are preset at the factory at 38°F (3°C) in the fresh food compartment and 0°F (-17°C) in the freezer compartment.

Adjusting the Control



24 hours after adding food, you may decide that one or both compartments should be colder or warmer. If so, adjust the control as indicated in the Temperature Control Guide.

- The first touch of the  or  pads shows the current temperature setting.
- The display will show the new setting for approximately three seconds, and then return to the actual temperature currently within that compartment.
- Do not change either control more than one degree at a time. Allow temperature to stabilize for 24 hours before making a new temperature adjustment.

Temperature Control Guide

Refrigerator too warm	Set the Refrigerator control to next higher number by pressing the  pad.
Refrigerator too cold	Set the Refrigerator control to next lower number by pressing the  pad.
Freezer too warm	Set the Freezer control to next higher number by pressing the  pad.
Freezer too cold	Set the Freezer control to next lower number by pressing the  pad.
Turn refrigerator OFF	Press the Freezer  pad until "OFF" appears in the display. Press either the Freezer or Refrigerator  pad to turn back on.



When activated, Speed Ice reduces the freezer temperature to the optimum setting for 24 hours in order to produce more ice. **Important:** When the Speed Ice feature is in operation, the  and  pads for the Freezer control will not operate.

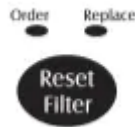

Reset Filter (select models)

When a water filter has been installed in the refrigerator, the yellow Order light will illuminate when 90 % of the volume of water for which the filter is rated has passed through the filter OR 11 months have elapsed since the filter has been installed.

The red Replace light will illuminate when the rated volume of water has passed through the filter OR 12 months have elapsed since the filter was installed. A new filter should be installed immediately when the Replace light is illuminated.

After replacing the filter, press and hold the Reset Filter pad for three seconds. The Order and Replace lights will go off.



Vacation Mode

The Vacation Mode feature causes the freezer to defrost less frequently, conserving energy. The Vacation Mode indicator light will illuminate when the feature is activated. To deactivate, press the Vacation Mode pad again OR open either door. The indicator light will go off.

Notes:

- Door openings will not deactivate Vacation Mode for approximately one hour after activation.
- If vacationing for more than a few days, see the Preparing for Vacation section, page 28.



Temp Alarm

The Temp Alarm system will alert you if the freezer or fresh food temperatures exceed normal operating temperatures due to a power outage or other event. When activated, the Temp Alarm light will illuminate.

If the freezer or fresh food temperatures have exceeded these limits, the display will alternately show the current compartment temperatures and the highest compartment temperatures reached when the power was out. An audible alarm will sound repeatedly.

Press the Temp Alarm pad once to stop the audible alarm. The Temp Alarm light will continue to flash and the temperatures will alternate until the temperatures have stabilized.

To turn off Temp Alarm, press and hold the Temp Alarm pad for three seconds. The indicator light will go off.





Door Alarm

The Door Alarm will alert you when one of the doors has been left open for five continuous minutes. When this happens, an audible alarm will sound every few seconds until the door is closed OR the Door Alarm pad is pressed to deactivate the feature.



Max Cool

When activated, Max Cool causes the fresh food and freezer temperatures to drop to the minimum settings on the control. This cools down the refrigerator and freezer after extended door openings or when loading the refrigerator or freezer with warm food. **Important:** When the Max Cool feature

is in operation, the  and  pads for the refrigerator and freezer controls will not operate.

To activate, press the Max Cool pad. Max Cool will deactivate automatically after 12 hours, OR press the Max Cool pad to deactivate the feature.

User Preferences

Access the User Preferences menu to:

- Activate or turn off Super Cool (select models).
- Change the temperature display from °F to °C .
- Enable or disable audible alarms.
- Adjust the light level at which the Dispenser Auto Light will illuminate (when this feature is activated on the ice and water dispenser) (select models).
- Activate the Sabbath Mode.

To access the User Preferences menu, press and hold the Door Alarm pad for three seconds. When in the User Preferences mode, a short title for the feature will appear in the Freezer temperature display and the feature status will appear in the Refrigerator display.

1. Use the Freezer up and down controls to scroll through the features.
2. When the desired feature is displayed, use the Refrigerator up and down controls to change the status.

3. When changes are complete, press the Door Alarm pad for three seconds OR close the Fresh Food door.

Super Cool (CC) (select models)

When Super Cool is ON, an air-mixing fan in the fresh food compartment is activated to improve air flow and temperature control. To save energy, this feature may be deactivated by pressing OFF.

Temperature Display (F_C)

Change the display to show temperatures in degrees Fahrenheit or degrees Celsius.

Door Alarm

The Door Alarm will alert you when one of the doors has been left open for five continuous minutes. When this happens, an audible alarm will sound every few seconds until the door is closed OR the Door Alarm pad is pressed to deactivate the feature.

Alarm (AL)

When the Alarm mode is OFF, all audible alarms will be disabled until the feature is turned ON.

Auto Light Level Selection (LL) (select models)

This setting adjusts the light level at which the dispenser light will illuminate when the sensor detects that the light levels in the room are low. Setting 1 is the darkest light level setting, setting 9 is the lightest light level setting. **Important:** The Auto Light (select models) must be activated on the ice and water dispenser control to take advantage of this option.

Sabbath Mode (SAB)

When the Sabbath Mode is ON, all control lights and the night light will be disabled until the feature is turned OFF. This feature does not disable the interior lights. Press any pad to restore the control lights.

Warm Cabinet Surfaces

At times, the front of the refrigerator cabinet may be warm to the touch. This is a normal occurrence that helps prevent moisture from condensing on the cabinet. This condition will be more noticeable when the refrigerator is first started, during hot weather and after excessive or lengthy door openings.

Fresh Food Features

Shelves

CAUTION

To avoid personal injury or property damage, observe the following:

- Never attempt to adjust a shelf that is loaded with food, except in the case of the Elevator™ Shelf.
- Confirm shelf is secure before placing items on shelf.
- Handle tempered glass shelves carefully. Shelves may break suddenly if nicked, scratched, or exposed to sudden temperature change.

Your refrigerator has either Spill-Catcher™ or nonsealed shelves. Spill-Catcher™ shelves have a spill retainer edge which allows for easier clean up and some are equipped with the Easy-Glide slide out feature. To slide out (select models), grasp the front of the shelf and pull forward. Push in the shelf to return to the original position.

To Remove a Shelf:

- Slightly tilt up the front and lift up the rear of the shelf, then pull the shelf straight out.

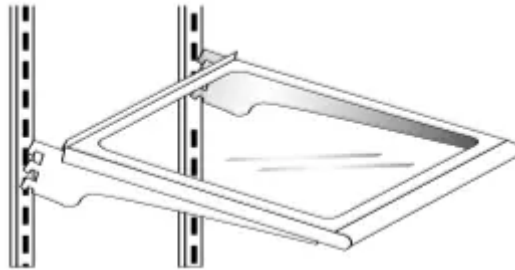

To Lock the Shelf Into Another Position:

- Tilt up the front edge of the shelf.
- Insert the hooks into the desired frame openings and let the shelf settle into place.
- Be sure the shelf is securely locked at the rear.

The Crisper Top serves as the lower fresh food shelf.

To Remove the Crisper Top:

- Remove drawers as indicated (see page 13).
- Place hand under the frame to push up the glass. Lift glass out.

To Install:

- Repeat above instructions in reverse order.

Elevator™ Shelf (select models)

The Elevator™ Shelf is equipped with a spill-retaining edge and the Easy-Glide™ slide-out feature. It can be adjusted up or down without unloading.

To Slide Out Elevator™ Shelf:

- Grasp the front of the shelf and pull forward.



- Push the shelf in to return to original position.

To Adjust the Elevator™ Shelf:

- Pull out the knob on the crank handle.
- Rotate the crank clockwise to raise the shelf, and counterclockwise to lower the height of the shelf.

To Remove Elevator™ Shelf:

- Completely unload the shelf and pull the shelf forward.
- Pull until the shelf stops.
- Press up on the tabs located underneath its outside edges and continue pulling forward until the shelf is clear of the frame.

To Replace Elevator™ Shelf:

- Align the shelf to the frame and push it all the way back. It is not necessary to press up on the tabs for reinstallation.

In ordinary use, the Elevator™ Shelf frame assembly does NOT require removal. Though unlikely, and not recommended, the correct removal procedure is as follows:

To Remove Frame Assembly:

- Unload the shelf completely.
- Slide the shelf forward about 2" and manually move the two rear latches toward the shelf center.
- While supporting the entire shelf and frame from underneath, lift slightly and rotate the assembly approximately 30° to allow the rear mechanism to clear the vertical rear side rails.
- The entire assembly can then be moved forward and clear of the refrigerator compartment.

To Reinstall Frame Assembly:

- Reverse the removal procedure. Be sure the shelf is in a level position. When the sliding shelf is pushed to the rear, it will reposition the rear latches to their correct operating position.

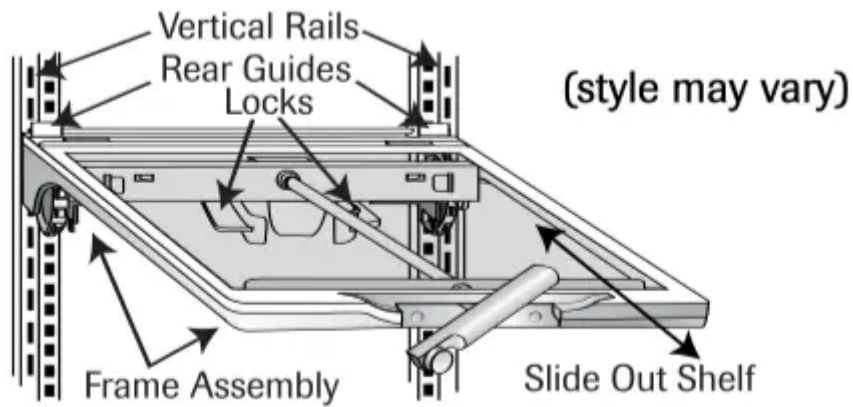

Refrigerator Pak Can Organizer (select models)

The Refrigerator Pak Can Organizer conveniently dispenses up to a 12-pack of individual beverage cans. To load beverages into the organizer:

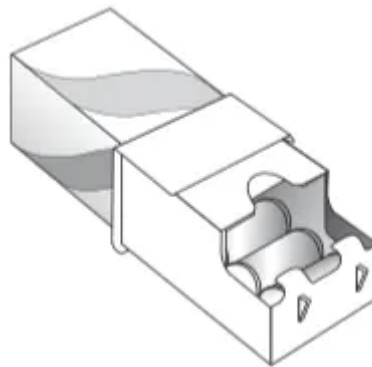

- Open a 12-pack sleeve of beverages.
- Slide can organizer over the cutout portion of beverage sleeve.
- Place container and sleeve in an upright position in a door bucket located in the fresh food door compartment.

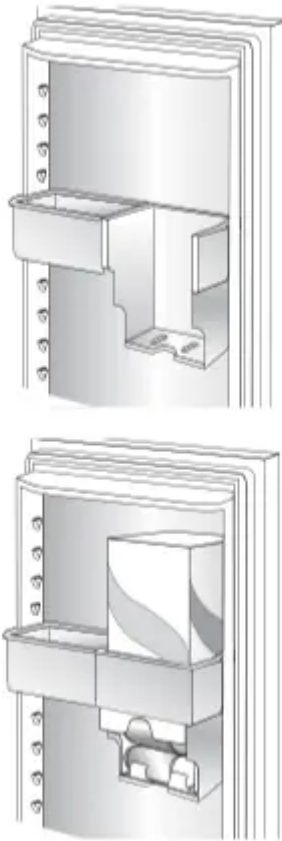

The dispenser sits in the door bucket and can be moved to accommodate a variety of storage needs.

Dairy Center

The Dairy Center provides convenient door storage for spreadable items such as butter and margarine. On select models, this compartment can be moved to several different locations to accommodate storage needs.

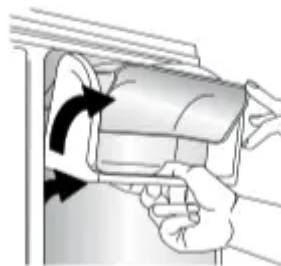

To Remove:

- Slide dairy center up and pull out.

To Install:

- Slide assembly in and down so that the hooks are firmly seated on the door liner.

To Remove Dairy Door:

- Press in sides of dairy door and pull out.

To Install Dairy Door:

- Slide sides of dairy door inside dairy center until hinge points snap into place.

Adjustable Deep Tilt-Out Door Buckets

(select models)

The Adjustable Deep Tilt-Out Door Bucket provides easy access to food items stored in the door.

To Remove Bucket:

- Tilt bucket out.
- Pull straight out of the bracket.

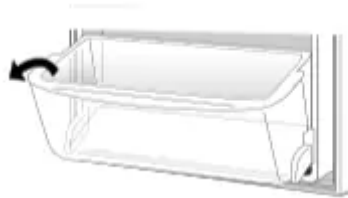

To Install Bucket:

- Tilt the front of the bucket down slightly.
- Slide into bracket and tip upright.

To Move Bucket Frame to Another Location:

- Remove bucket.
- Lift bracket up and pull straight out.
- Place the bracket in a new location.



Door Buckets

Door Buckets can be moved to meet individual storage needs.

To Remove:

- Lift bucket up and pull straight out.

To Install:

- Place bucket in desired door liner retainer, push down until bucket stops.

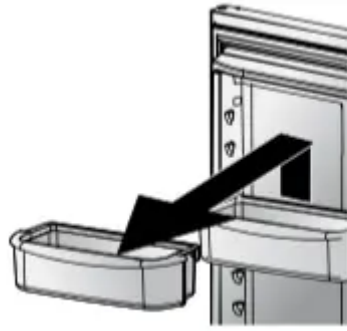

Storage Drawers

Humidity-Controlled Crisper Drawers

The Crisper Drawers provide a higher humidity environment for fresh fruit and vegetable storage.

Controls

The crisper controls regulate the amount of humidity in the crisper drawer. Slide control toward the FRUIT setting for produce with outer skins. Slide control toward the VEGETABLES setting for leafy produce.

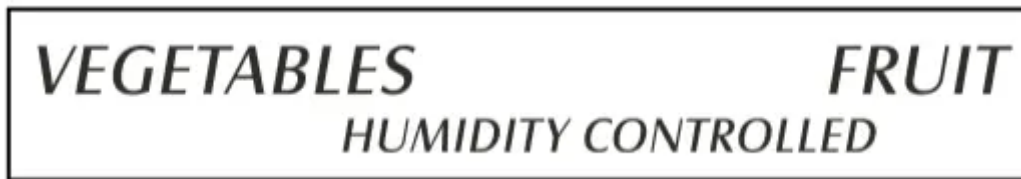

To Remove:

- Pull drawer out to full extension. (On select models, press tabs toward oneself to release drawer from rails.) Tilt up front of drawer and pull straight out.

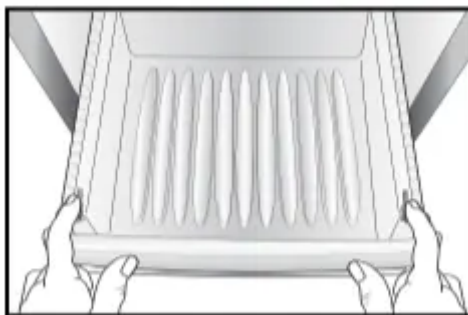

To Install:

- Insert drawer into frame rails and push back into place.

Note: For best results, keep the crispers tightly closed.

Automatic Humidity Control

Some crispers are equipped with an Automatic Humidity Control system, eliminating the need for manual humidity slide controls on the drawer. A fabric-like material* covers small air vents in the shelf insert above the crispers.



This material controls the flow of moisture out of the crisper. If a food spill should occur on the air vent or fabric-like material, wipe with a clean, damp cloth.

* The Maytag Automatic Humidity Control system features a unique, patented material called Shape Memory Polymer (SMP) that when laminated to fabric, becomes DIAPLEX. DIAPLEX is manufactured by Mitsubishi.



To Remove:

- Pull drawer out to full extension. Tilt up front of drawer and pull straight out.

To Install:

- Insert drawer into frame rails and push back into place.

Note: For best results, keep the crispers tightly closed.

Temperature-Controlled Drawer (select models)

This drawer can be used for storage of miscellaneous items.

The drawer features a control that regulates the air temperature in the drawer. Set the control to Cheese to provide normal refrigerator temperature. Use the Meats setting for meats.



Can Rack™ (select models)

The Can Rack™ slides out from underneath the Spillsaver™ stationary shelf. The Can Rack™ holds up to twelve 12-ounce beverage cans.



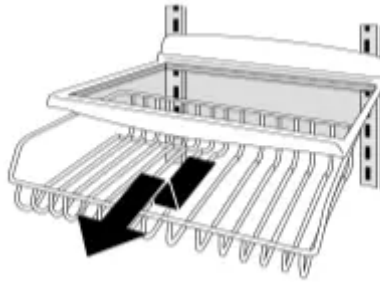

To Remove:

- Empty contents of Can Rack™. Pull forward to full extension and lift front to release from shelf rail assembly. Pull straight out to remove.

To Install:

- Insert drawer into frame rails and push back into place.

Accessories

Grip Pads (select models)

The Grip Pads prevent objects from sliding in the door buckets. Grip Pads are removable and are top-rack dishwasher safe for easy cleaning.



Covered Storage Bucket

(select models)

The Storage Bucket has a lid and removable egg tray. When tray is removed, bucket will accept items such as a standard egg carton, ice, etc.

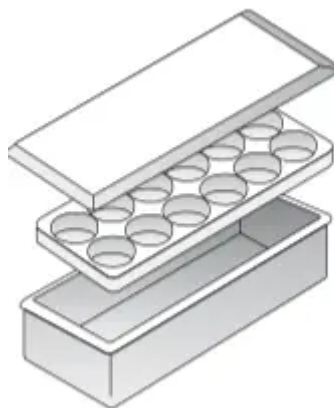

Tall Bottle Retainer/Snugger

(select models)

The Tall Bottle Retainer prevents tall bottles from tipping forward. The Retainer can be placed above any removable door bucket.

The Snugger attached to the Tall Bottle Retainer keeps bottles and other containers in place when the door is opened or closed. Adjust the Snugger by sliding from side to side.

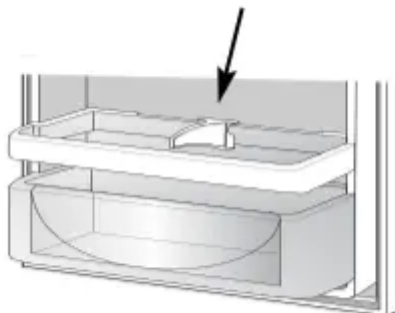

Egg Tray With Handle

(style may vary/select models)

The Egg Tray with Handle holds a “dozen-plus” eggs. It can be removed to carry to a work area or to be washed.



Wine Rack (select models)

The Wine Rack provides a place for horizontally storing wine. The rack can also hold an egg carton.

Position the rack to rest on the left hand side of a refrigerator shelf (this rack cannot be positioned on an Elevator Shelf™).

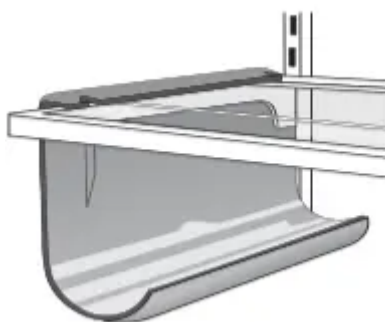

Freezer Features

Shelves and Baskets

Fixed Freezer Shelf

To Remove Clip-Mounted Shelves:

- Lift shelf from wall mounting clips and pull left side of shelf out of wall mounting holes.

To Install Clip-Mounted Shelves:

- Place left side of shelf in mounting holes and press down into wall mounting clips.

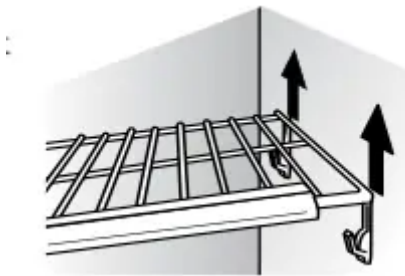

Shelves

Shelves can be removed to meet individual storage needs.

To Remove Shelf:

- Snap right side of shelf up from cabinet railing and slide to right.

To Install Shelf:

- Place shelf in left side cabinet railing snapping shelf into right side cabinet railing.

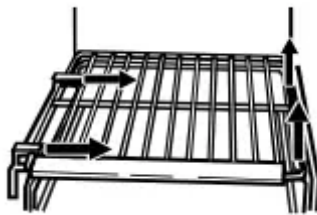

Baskets and Drawers

Baskets and drawers (style may vary) slide out for easy access to items in back.

To Remove:

- Pull out to its full extension. Lift up front of basket and remove.

To Install:

- Slide basket or drawer into cabinet railing. Lift up front of basket or drawer, and slide to the back of refrigerator.



Ice Storage Bin

The Ice Storage Bin is located below the automatic ice maker.

To Remove:

- Raise ice maker arm to deactivate ice maker. Lift front of bin and pull out to its full extension. Lift up front of bin and remove.

To Install:

- Slide bin into railing below ice maker until bin locks into place. Drop ice maker arm to activate ice maker.

Important: Ice bin must be locked in place for proper ice dispensing. Turn auger driver behind bin counterclockwise (as shown) to properly align ice bin with auger driver.



Door Storage

Adjustable Door Buckets

Door Buckets can be moved to meet individual storage needs.

To Remove:

- Lift the door bucket up until it clears the retainers on the door liner, then pull the door bucket straight out.

To Install:

- Slide bucket in above desired door liner retainer push down until bucket stops.

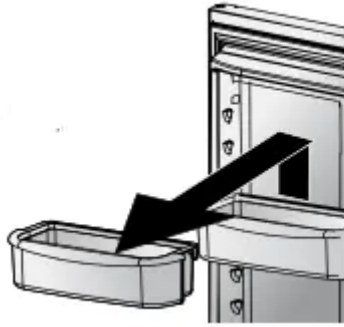

Fixed Door Bucket (select models)

The Fixed Door Bucket is located in the upper section of the freezer door.

Important: Fixed door bucket is NOT adjustable. If bucket is removed, freezer light will not deactivate when door is closed.

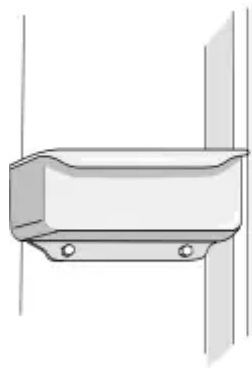

Drop-Down Freezer

(select models)

These baskets provide convenient storage space for frozen food items that tend to shift, such as bagged vegetables.

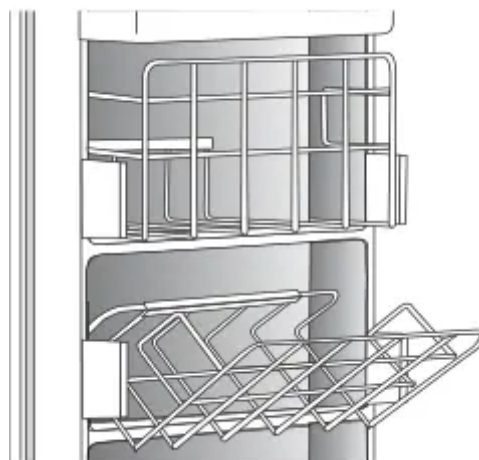

Ice and Water

Automatic Ice Maker

(non-dispenser models)

Note: Energy rating guides that are posted on the refrigerator at the time of purchase do not include optional ice maker energy usage.

Some models are automatic ice maker ready. The number of the appropriate ice maker kit is IC10S. The kit contains installation instructions and water connection instructions.

Other models have a factory installed ice maker. Connect the ice maker to the water supply as instructed on pages 5-6. Proper water flow and a level refrigerator are essential for optimal ice maker performance.

Operating Instructions

- Confirm ice bin is in place and ice maker arm is down.
- After freezer section reaches between 0° to 2°F (-18° to -17°C), ice maker fills with water and begins operating. You will have a complete harvest of ice approximately every three hours.

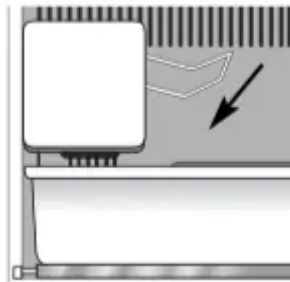

- Allow approximately 3-6 hours after installation to receive first harvest of ice.
- Discard ice created within first 12 hours of operation to verify system is flushed of impurities.
- Stop ice production by raising ice maker arm until click is heard.
- Ice maker will remain in the OFF position until arm is pushed down.
- The first one or two batches will probably contain undersized and irregular cubes because of air in the supply line.
- When the ice cubes are ejected it is normal for several cubes to be joined together at the ends. They can easily be broken apart. The ice maker will continue to make ice until the supply of ice cubes raises the sensor arm, shutting the ice maker off.

- Certain sounds may accompany the various cycles of the ice maker. The motor may have a slight hum, the cubes will rattle as they fall into an empty storage pan and the water valve may click or “buzz” occasionally.
- If the ice is not used frequently, the ice cubes will become cloudy, shrink, stick together and taste stale. Empty the ice storage bin periodically and wash it in lukewarm water. Be sure to dry the bin thoroughly before replacing it.
- Beverages and foods should not be placed in the ice storage bin for quick chilling. These items can block the sensor arm, causing the ice maker to malfunction.
- Turn OFF (arm up) the ice maker when the water supply is to be shut off for several hours.

To Remove the Ice Bin:

- Pull it forward, away from the ice maker. To avoid the ice maker dumping ice while the bin is removed, turn the ice maker OFF by raising the sensor arm.

To Install the Ice Bin:

- Reverse the above procedure. Turn the ice maker ON by lowering the sensor arm.

WARNING

To avoid personal injury or property damage, observe the following:

- Do not place fingers or hands on the automatic ice making mechanism while the refrigerator is plugged in. This will help protect you from possible injury. It will also prevent interference with moving parts of the ejector mechanism and the heating element that releases the cubes.
- Under certain rare circumstances, ice cubes may be discolored, usually appearing with a greenbluish hue. The cause of this unusual discoloration can be a combination of factors such as certain characteristics of local waters, household plumbing and the accumulation of copper salts in an inactive water supply line which feeds the ice maker. Continued consumption of such discolored ice cubes may be injurious to health. If such discoloration is observed, discard the ice cubes and contact your dealer to purchase and install a water line filter.
- Water damage due to improper water connection may cause mold/mildew growth.
- Clean up water and ice spills to avoid personal injury and to prevent mold/mildew growth.

Dispenser Features

(select models)

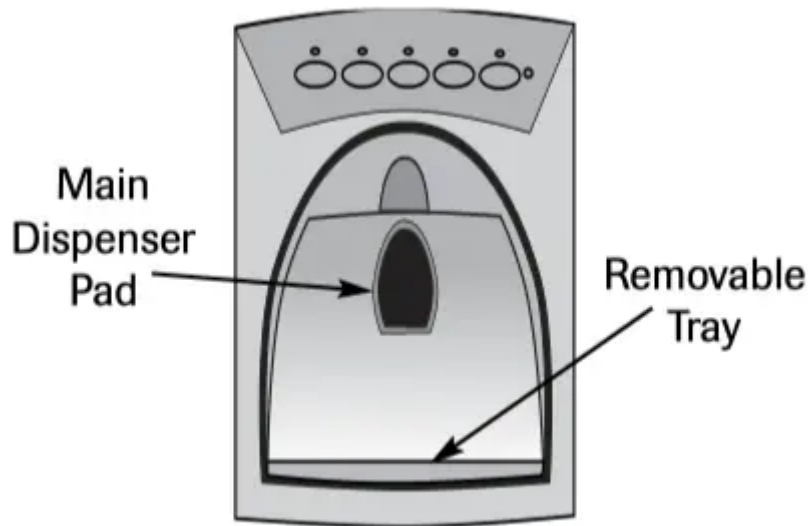

Dispenser Light (select models)

A light activates within the dispenser area at full power when dispensing ice or water with the main dispenser pad.

Dispenser Pad

The Dispenser Pad is located on the back wall of the dispensing area. When the dispenser pad is pressed, the selection chosen on the dispenser control panel will dispense.

Removable Tray

The Removable Tray at the bottom of the dispenser area is designed to collect small spills and may be easily removed for cleaning and emptying purposes.

Important: Removable tray does not drain. Do not allow tray to overflow. If it does, remove tray and wipe up overflow.

Water Dispenser Operation

CAUTION

To avoid personal injury or property damage, observe the following:

- Do not put fingers, hands or any foreign object into dispenser opening.
- Do not use sharp objects to break ice.
- Do not dispense ice directly into thin glass, fine china or delicate crystal.

Note: During initial use of water dispenser, there will be a one- to two-minute delay while water tank fills before water dispenses. Discard first 10-14 glasses of water after initially connecting refrigerator to household water supply and after extended periods of nonuse.

To Use Dispenser Pad:

- Choose water selection from dispenser control panel.

- Press a sturdy, wide-mouthed container against dispenser pad. When dispensing crushed ice, hold container as close to chute as possible to reduce spraying.
- Release pressure on dispenser pad to stop water dispensing. A small amount of water may continue to dispense and collect in dispenser tray. Large spills should be wiped dry.

Dispenser Control (select models)

(control features vary by model)

Ice Dispenser Operation

To Dispense Ice and Water:

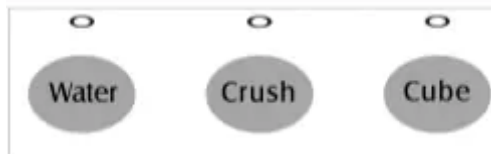

- Select Water, Crush or Cube ice mode by pushing button on dispenser control panel. A green light above button indicates mode selection.
- Press container against dispenser pad. When dispensing crushed ice, hold container as close to chute as possible to reduce spraying.

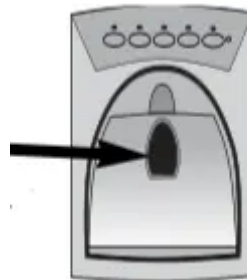

Notes:

- Mode may not be changed while ice dispenser is in operation.
- If dispenser (select models) is active for more than five minutes, an automatic lock out sensor will shut down power to dispenser area. See Dispenser Lock for unlocking information.

Dispenser Lock (select models)

The Dispenser Lock prevents ice or water from being dispensed.



To Lock Dispenser:

- Press and hold the Lock button for three seconds. A green indicator light above button will illuminate when the dispenser is locked.

To Unlock Dispenser:

- Hold the Lock button for three seconds. The green indicator light above button will go out.

Water Filter Status Indicator Light (select models)

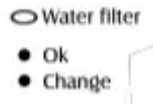

The Water Filter Status Indicator Light serves as a reminder to replace the water filter. A green light indicates that the filter is in good condition. A red light indicates the filter should be changed. Once light turns red, it will remain red until function is reset.

To Reset Indicator:

- Press and hold both the Lock and Water buttons simultaneously for four seconds. The green filter status indicator light will flash three times when the function has successfully reset.

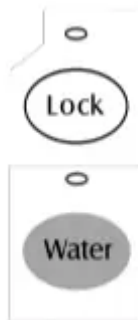

Auto Light (select models)

The Auto Light function activates the dispenser light at half-power when the Light Sensor detects that the light levels in room are low.

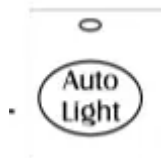

To Activate Auto Light:

- Press Auto Light button. A green indicator light above button illuminates when the sensor is active.

To Deactivate Auto Light:

- Press Auto Light button. The green indicator light will go out.

Note: The dispenser light will operate when Auto Light is ON or OFF.

Light (select models)

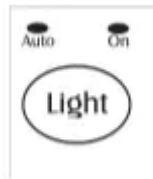

Press the Light pad once to select the Auto Light function which activates the dispenser light at half-power when the light sensor detects that the light levels in room are low. The Auto indicator light will illuminate.

To Activate Light:

- Press the Light pad again to turn the dispenser light on continuously. The On indicator light will illuminate.

To Deactivate Light:

- Press the Light pad a third time to turn the dispenser light off.

Sabbath Mode (select models)

When activated, the Sabbath Mode deactivates the control lights while leaving the control operational.

To Activate Sabbath Mode:

- Press and hold the Lock and Auto Light buttons simultaneously for three to four seconds. After three to four seconds, the dispenser lights will turn off.



To Deactivate Sabbath Mode:

- Press and hold both the Lock and Auto Light buttons simultaneously for three to four seconds. After three to four seconds, the dispenser lights will activate.

Notes:

- Dispenser light will not activate during dispensing while in this mode.

- If the power fails, the control will remain in Sabbath Mode when power returns.

FrontFill™ Button (select models)



The FrontFill™ button works independently of the dispenser controls, providing an up-front alternative to the dispenser pad for dispensing water. This feature is convenient for filling large items that will not fit into the dispenser area (i.e. sport bottles, pitchers, large pans, coffee pots).

This feature allows added convenience of dispensing ice and water simultaneously. To use, choose your preferred ice mode from dispenser control panel. Press container against dispenser pad while pressing the FrontFill™ button.

Water Filter

Water Filter Removal and Installation (select models)

WARNING

Important: Air trapped in system may cause water and cartridge to eject. Use caution when removing.

To avoid serious illness or death, do not use refrigerator where water is unsafe or of unknown quality without adequate disinfection before or after use of filter.

CAUTION

After installing a new water filter, always dispense water for two minutes before removing the filter for any reason. Air trapped in system may cause water and cartridge to eject. Use caution when removing.

- The bypass cap does not filter water. Be sure to have replacement cartridge available when filter change is required.
- If water filtration system has been allowed to freeze, replace filter cartridge.
- If system has not been used for several months, or water has an unpleasant taste or odor, flush system by dispensing water for two to three minutes. If unpleasant taste or odor persists, change filter cartridge.

Initial Installation

The water filter is located in the upper right-hand corner of the fresh food compartment.

1. Remove blue bypass cap and retain for later use.
2. Remove sealing label from end of filter and insert into filter head.
3. Rotate gently clockwise until filter stops. Snap filter cover closed.

4. Reduce water spurts by flushing air from system.

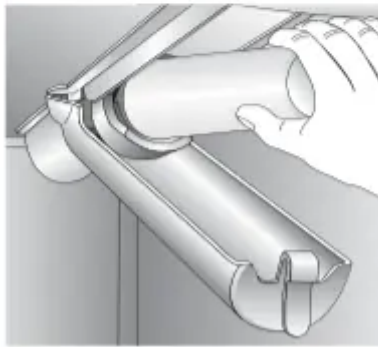
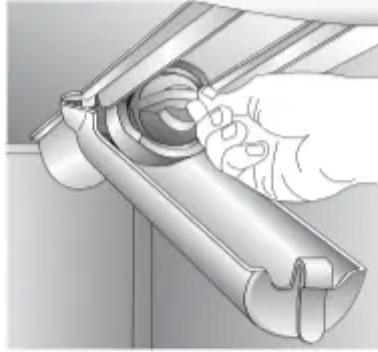

Run water continuously for two minutes through dispenser until water runs steady. During initial use, allow about a one- to two-minute delay in water dispersal to allow internal water tank to fill.

- Additional flushing may be required in some households where water is of poor quality.

Replacing Water Filter

Important: Air trapped in system may cause water and cartridge to eject. Use caution when removing.

1. Turn filter counterclockwise until it releases from filter head.
2. Drain water from filter into sink, and dispose in normal household trash.
3. Wipe up excess water in filter cover and continue with Initial Installation, steps 2 and 4.

The filter should be changed at least every 12 months.

Important: Condition of water and amount used determines life span of water filter cartridge. If water use is high, or if water is of poor quality, replacement may need to take place more often.

To purchase a replacement water filter cartridge, contact your dealer or call 1-877-232-6771 USA or 1-800-688-8408 Canada.

The dispenser feature may be used without a water filter cartridge. If you choose this option, replace filter with blue bypass cap.

Food Storage Tips

Fresh Food Storage

- The fresh food compartment of a refrigerator should be kept between 34°-40°F (1°-4°C) with an optimum temperature of 37°F (3°C). To check the temperature, place an appliance thermometer in a glass of water and place in the center of the refrigerator. Check after 24 hours. If the temperature is above 40°F (4°C) adjust the controls as explained on pages 8 and 9.
- Avoid overcrowding the refrigerator shelves. This reduces the circulation of air around the food and results in uneven cooling.

Fruits and Vegetables

- Storage in the crisper drawers traps humidity to help preserve the fruit and vegetable quality for longer time periods (see pages 12 and 13).
- Sort fruits and vegetables before storage and use bruised or soft items first. Discard those showing signs of decay.
- Always wrap odorous foods such as onions and cabbage so the odor does not transfer to other foods.
- While vegetables need a certain amount of humidity to remain fresh, too much humidity can shorten storage times (especially leafy vegetables). Drain vegetables well before storing.
- Wait to wash fresh produce until right before use.

Meat and Cheese

- Raw meat and poultry should be wrapped securely so leakage and contamination of other foods or surfaces does not occur.
- Occasionally mold will develop on the surface of hard cheeses (Swiss, Cheddar, Parmesan). Cut off at least an inch around and below the moldy area. Keep your knife or instrument out of the mold itself. Do not try to save individual cheese slices, soft cheese, cottage cheese, cream, sour cream or yogurt when mold appears.

Dairy Food

- Most dairy foods such as milk, yogurt, sour cream and cottage cheese have freshness dates on their cartons for appropriate length of storage. Store these foods in the original carton and refrigerate immediately after purchasing and after each use.

Frozen Food Storage

- The freezer compartment of a refrigerator should be kept at approximately 0°F (-17°C). To check the temperature, place an appliance thermometer between the frozen packages and

check after 24 hours. If the temperature is above 0°F (-17°C), adjust the control as described on pages 8 and 9.

- A freezer operates more efficiently when it is at least 2/3 full.

Packaging Foods for Freezing

- To minimize dehydration and quality deterioration use aluminum foil, freezer wrap, freezer bags or airtight containers. Force as much air out of the packages as possible and be sure they are tightly sealed. Trapped air can cause the food to dry out, change color and develop an off-flavor (freezer burn).
- Overwrap fresh meats and poultry with suitable freezer wrap prior to freezing.
- Do not refreeze meat that has completely thawed.

Loading the Freezer

- Avoid adding too much warm food to the freezer at one time. This overloads the freezer, slows the rate of freezing and can raise the temperature of frozen foods.
- Leave space between the packages so cold air can circulate freely, allowing food to freeze as quickly as possible.
- Avoid storing hard-to-freeze foods such as ice cream and orange juice on the freezer door shelves. These foods are best stored in the freezer interior where the temperature varies less with door openings.

Refer to the Food Storage Chart on pages 23 and 24 for approximate storage times.

Food Storage Chart

Storage times are approximate and may vary depending on type of packaging, storage temperature, and the quality of the food when purchased.

FOODS	REFRIGERATOR	FREEZER	STORAGE TIPS
DAIRY PRODUCTS			
Butter	1 month	6 to 9 months	Wrap tightly or cover.
Milk and cream	1 week	Not recommended	Check carton date. Close tightly. Do not return unused portions to original container. Do not freeze cream unless whipped.
Cream cheese, cheese spread and cheese food	1 to 2 weeks	Not recommended	Wrap tightly.
Cottage cheese	3 to 5 days	Not recommended	Store in original carton. Check carton date.
Sour cream	10 days	Not recommended	Store in original carton. Check carton date.
Hard cheese (Swiss, Cheddar and Parmesan)	1 to 2 months	4 to 6 months May become crumbly	Wrap tightly. Cut off any mold.
EGGS			
Eggs in the shell	3 weeks	Not recommended	Refrigerate small ends down.
Leftover yolks or whites	2 to 4 days	9 to 12 months	For each cup of yolks to be frozen, add 1 tsp. sugar for use in sweet, or 1 tsp. salt for non-sweet dishes.
FRUITS			

Apples	1 month	8 months (cooked)	May also store unripe or hard apples at 60°to 70°F (16°to 21°C).
Bananas	2 to 4 days	6 months (whole/ peeled)	Ripen at room temperature before refrigerating. Note: Bananas will darken when refrigerated.
Pears, plums, avocados	3 to 4 days	Not recommended	Ripen at room temperature before refrigerating. Note: Avocados will darken when refrigerated.
Berries, cherries, apricots	2 to 3 days	6 months	Ripen at room temperature before refrigerating.
Grapes	3 to 5 days	1 month (whole)	Ripen at room temperature before refrigerating.
Citrus fruits	1 to 2 weeks	Not recommended	May also store at 60°to 70°F (16°to 21°C). If refrigerated, store uncovered.
Pineapples, cut	2 to 3 days	6 to 12 months	Will not ripen after purchase. Use quickly.

VEGETABLES			
Asparagus	1 to 2 days	8 to 10 months	Do not wash before refrigerating. Store in crisper.
Brussels sprouts, broccoli, cauliflower, green peas, lima beans, onions, peppers	3 to 5 days	8 to 10 months	Wrap odorous foods. Leave peas in pods.
Cabbage, celery	1 to 2 weeks	Not recommended	Wrap odorous foods and refrigerate in crisper.
Carrots, parsnips, beets and turnips	7 to 10 days	8 to 10 months	Remove tops. Wrap odorous foods and refrigerate in the crisper.
Lettuce	7 to 10 days	Not recommended	
POULTRY and FISH			
Chicken and turkey, whole	1 to 2 days	12 months	Keep in original packaging for refrigeration. Place in the meat and cheese drawer. When freezing longer than two weeks, overwrap with freezer wrap.
Chicken and turkey, pieces	1 to 2 days	9 months	
Fish	1 to 2 days	2 to 6 months	
MEATS			
Bacon	7 days	1 month	



Beef or lamb, ground	1 to 2 days	3 to 4 months	Fresh meats can be kept in original packaging for refrigeration.
Beef or lamb, roast and steak	3 to 5 days	6 to 9 months	Place in the meat and cheese drawer. When freezing longer than two weeks, overwrap with freezer wrap.
Ham, fully cooked, whole	7 days	1 to 2 months	
half	5 days	1 to 2 months	
slices	3 days	1 to 2 months	
Luncheon meat	3 to 5 days	1 to 2 months	Unopened, vacuum-packed luncheon meat may be kept up to two weeks in the meat and cheese drawer.
Pork, roast	3 to 5 days	4 to 6 months	
Pork, chops	3 to 5 days	4 months	
Sausage, ground	1 to 2 days	1 to 2 months	
Sausage, smoked	7 days	1 to 2 months	
Veal	3 to 5 days	4 to 6 months	
Frankfurters	7 days	1 month	Processed meats should be tightly wrapped and stored in the meat and cheese drawer.

Sources: United States Department of Agriculture; Food Marketing Institute; Cooperative Extension Service, Iowa State University

Care and Cleaning

WARNING

To avoid electrical shock which can cause severe personal injury or death, disconnect power to refrigerator before cleaning. After cleaning, reconnect power.

CAUTION

To avoid personal injury or property damage, observe the following:

- Read and follow manufacturer's directions for all cleaning products.
- Do not place buckets, shelves or accessories in dishwasher. Cracking or warping of accessories may result.

Refrigerator Cleaning Chart



PART	DO NOT USE	DO
<p>Smooth or Textured Painted Doors and Exterior (select models)</p> <p>Damage to finish due to improper use of cleaning products or non-recommended products is not covered under this product's warranty.</p>	<p>Abrasive or harsh cleaners Ammonia Chlorine bleach Concentrated detergents or solvents Metal or plastic-textured scouring pads</p>	<p>Use 4 tablespoons of baking soda dissolved in 1 quart (1 liter) warm, soapy water.</p> <p>Rinse surfaces with clean, warm water and dry immediately to avoid water spots.</p>
<p>Cabinet Interior</p>		
<p>Stainless Steel Doors and Exterior (select models)</p> <p>Important:</p> <p>Damage to stainless steel finish due to improper use of cleaning products or non-recommended products is not covered under this product's warranty.</p>	<p>Abrasive or harsh cleaners Ammonia Chlorine bleach Concentrated detergents or solvents Metal or plastic-textured scouring pads Vinegar-based products Citrus-based cleaners</p>	<p>Use warm, soapy water and a soft, clean cloth or sponge.</p> <p>Rinse surfaces with clean, warm water and dry immediately to avoid water spots.</p> <p>To polish and help prevent fingerprints, follow with Stainless Steel Magic Spray (part no. 20000008*).</p>
<p>Door Gaskets</p>	<p>Abrasive or harsh cleaners Metal or plastic-textured scouring pads</p>	<p>Use warm, soapy water and a soft, clean cloth or sponge.</p>
<p>Condenser Coil Remove base grille to access.</p>	<p>Anything other than a vacuum cleaner</p>	<p>Use a vacuum cleaner hose nozzle.</p>
<p>Condenser Fan Outlet Grille See back of refrigerator.</p>		<p>Use a vacuum cleaner hose nozzle with brush attachment.</p>



<p>Accessories Shelves, buckets, drawers, etc.</p>	<p>A dishwasher</p>	<p>Follow removal and installation instructions from appropriate feature section.</p> <p>Allow items to adjust to room temperature. Dilute mild detergent and use a soft, clean cloth or sponge for cleaning.</p> <p>Use a plastic bristle brush to get into crevices. Rinse surfaces with clean, warm water.</p> <p>Dry glass and clear items immediately to avoid spots.</p>
---	---------------------	--

Removing Odors From Refrigerator

WARNING

To avoid electrical shock which can cause severe personal injury or death, disconnect power to refrigerator before cleaning. After cleaning, reconnect power.

1. Remove all food and turn the refrigerator OFF.
2. Disconnect power to the refrigerator.
3. Clean the walls, floor, ceiling of cabinet interior, drawers, shelves and gaskets according to the instructions (see page 25).
4. Dilute mild detergent and brush solution into crevices using a plastic bristle brush. Let stand for five minutes. Rinse surfaces with warm water. Dry surfaces with a soft, clean cloth.
5. Wash and dry all bottles, containers and jars. Discard spoiled or expired items.
6. Wrap or store odor-causing foods in tightly sealed containers to prevent reoccurring odors.
7. Reconnect power to refrigerator and return food to refrigerator.
8. Allow the refrigerator to cool.
9. After 24 hours, check if odor has been eliminated.

If odor is still present:

1. Remove drawers and place on top shelf of refrigerator.
2. Pack refrigerator and freezer sections – including doors – with crumpled sheets of black and white newspaper.
3. Place charcoal briquettes randomly on crumpled newspaper in both freezer and refrigerator compartments.
4. Close doors and let stand 24 to 48 hours.

Energy Saving Tips

- Avoid overcrowding refrigerator shelves. This reduces air circulation around food and causes refrigerator to run longer.
- Avoid adding too much warm food to refrigerator at one time. This overloads compartments and slows rate of cooling.
- Do not use aluminum foil, wax paper, or paper toweling as shelf liners. This decreases air flow and causes refrigerator to run less efficiently.
- A freezer that is two-thirds full runs most efficiently.
- Locate refrigerator in coolest part of room. Avoid areas of direct sunlight, or near heating ducts, registers or other heat producing appliances. If this is not possible, isolate exterior by using a section of cabinet or an added layer of insulation.
- Clean door gaskets every three months according to cleaning instructions. This will assure that door seals properly and refrigerator runs efficiently.
- Take time to organize items in refrigerator to reduce time that door is open.
- Be sure your doors are closing securely by leveling refrigerator as instructed in your installation instructions.
- Clean condenser coils as indicated in the cleaning instructions every three months. This will increase energy efficiency and cooling performance.

Replacing Light Bulbs

WARNING

To avoid electrical shock which can cause severe personal injury or death, disconnect power to refrigerator before replacing light bulb. After replacing light bulb, reconnect power.

CAUTION

To avoid personal injury or property damage, observe the following:

- Allow light bulb to cool.
- Wear gloves when replacing light bulb.

Upper Fresh Food Section

The upper fresh food light bulbs are located behind the front panel. Reach behind the panel to remove the bulbs.

Lower Fresh Food Section

1. Push up on bottom tabs on light cover. Rotate cover up and release tabs.
2. Remove light bulb.
3. Replace bulb with appliance bulb no greater than 40 watts.
4. Insert top tabs of light cover into liner slots and snap bottom tabs into liner slots.



Upper Freezer Section

1. Remove ice bin by lifting front of bin and pulling out.
2. Remove light shield by pressing the upper right side of the shield and rotating downward.
3. Remove light bulb. Replace with appliance bulb no greater than 40 watts.
4. Rotate the shield upward, press in slightly and snap into place.
5. Replace ice bin by sliding in until bin locks into place.



Lower Freezer Section

1. Pinch both sides of light cover to remove.
2. Remove light bulb. Replace with appliance bulb no greater than 40 watts.
3. Pinch both sides of the light cover to snap into place.

Ice and Water Dispenser

1. Locate light bulb inside top edge of dispenser frame. Unscrew to remove.
2. Replace light bulb with a 7-watt, 120 volt bulb.

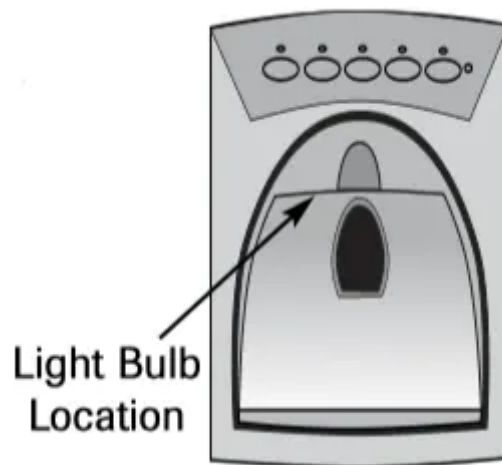

Preparing for Vacation

CAUTION

If your refrigerator has a dispenser and there is any possibility that the temperature can drop below freezing where the refrigerator is located, the water supply system (including the water tank and the water valve) must be drained by a qualified servicer.

For short vacations or absences (three months or less):

1. Remove all perishables.
2. If no one will be checking in on the refrigerator during your absence, remove all frozen items also.
3. If your refrigerator has an automatic ice maker:
 - Shut off the water supply to the ice maker at least one day ahead of time.
 - After the last load of ice drops, raise the wire shut off arm to the OFF position.
 - Empty the ice bin.
4. If the room temperature will drop below 55°F (12°C), follow the instructions for longer absences.

For long vacations, absences (more than three months) OR if the room temperature will drop below 55°F (12°C):

1. Remove food.
2. If your refrigerator has an automatic ice maker:
 - Shut off the water supply to the ice maker at least one day ahead of time.
 - After the last load of ice drops, raise the wire shut off arm to the OFF position.
 - Empty the ice bin.
3. If your refrigerator has a dispenser system with water filter, remove the water filter cartridge and install the filter bypass. Dispose of the used cartridge.
4. Turn the Freezer control to OFF.
5. Unplug the refrigerator.
6. Thoroughly clean the interior of both compartments with a baking soda solution and a clean, soft cloth (four tablespoons of baking soda in one quart of warm water.).
7. Dry thoroughly.
8. Leave the doors open to prevent the formation of mold and mildew.

Upon Your Return:

After a Short Vacation or Absence:

For models with automatic ice makers or dispensers:

- Reconnect the water supply and turn on supply valve (see pages 5-6).
- Monitor water connection for 24 hours and correct leaks if necessary.
- Run 10-15 glasses of water from the dispenser to flush out the system.
- Restart the ice maker.
- Discard at least the first three ice harvests.

After a Long Vacation or Absence:

- If your refrigerator has an automatic ice maker, reconnect the water supply and turn on supply valve (see pages 5-6).
- Plug the refrigerator back in and reset controls (see pages 8, 9 and 10).
- Empty the ice bin.
- Monitor water connection for 24 hours and correct leaks, if necessary.

For dispenser models, run water through the dispenser for at least three minutes with the filter bypass in place, then install water filter (see page 19).

- After installing the water filter, run water through the dispenser continuously for at least two minutes, or until water runs steady. Initially you may notice a one to two minute delay in water dispersal as the internal tanks fills.
- Restart the ice maker.
- Discard ice produced within the first 12 hours (at least the first three harvests).

Preparing to Move

- Follow the instructions for long vacations/absences, through step 7.
- Secure all loose items such as shelves and drawers by taping them securely in place to prevent damage.
- Tape the doors shut.
- Use an appliance dolly when moving the refrigerator. ALWAYS truck the refrigerator from its side or back NEVER from its front.
- Be sure the refrigerator stays in an upright position during moving.

Operating Sounds

Improvements in refrigeration design may produce sounds in your new refrigerator that are different or were not present in an older model. These improvements were made to create a refrigerator that is better at preserving food, is more energy efficient, and is quieter overall. Because new units run quieter, sounds may be detected that were present in older units, but were masked by higher sound levels. Many of these sounds are normal. Please note that the surfaces adjacent to a refrigerator, such as hard walls, floors and cabinetry may make these sounds seem even louder. The following are some of the normal sounds that may be noticed in a new refrigerator.

SOUND	POSSIBLE CAUSE	SOLUTION
Clicking	• Freezer control (A) clicks when starting or stopping compressor.	• Normal operation
	• Defrost timer or electric damper control (select models) (B) sounds like an electric clock and snaps in and out of defrost cycle.	• Normal operation
Air rushing or whirring	• Condenser fan (D) makes this noise while operating.	• Normal operation
	• Freezer fan (C) makes this noise while operating.	• Normal operation
	• Freezer fan (C) slows to a stop as the freezer door is opened.	• Normal operation
Gurgling or boiling sound	• Evaporator (E) and heat exchanger (F) refrigerant make this noise when flowing.	• Normal operation
Thumping	• Ice cubes from ice maker drop into ice bucket (G) .	• Normal operation
	• Dispenser ice chute (H) closing.	• Normal operation
Vibrating noise	• Compressor (I) makes a pulsating sound while running.	• Normal operation
	• Refrigerator is not level.	• See <i>Leveling</i> , pages 4-5.
Buzzing	• Ice maker water valve (J) hookup buzzes when ice maker fills with water.	• Normal operation
Humming	• Ice maker (K) is in the 'on' position without water connection.	• Normal operation
	• Ice auger (L) hums as auger agitates ice during dispensing.	• Stop sound by raising ice maker arm to OFF position. See <i>Automatic Ice Maker</i> , page 16 for details.
	• Compressor (I) can make a high-pitched hum while operating.	• Normal operation
	• Solenoid valve (M) operating ice chute door.	• Normal operation

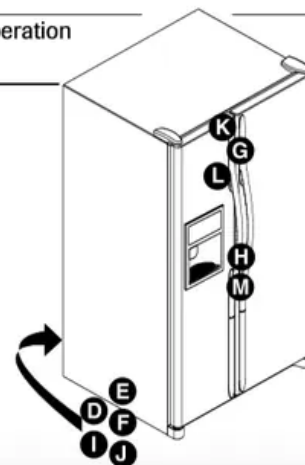
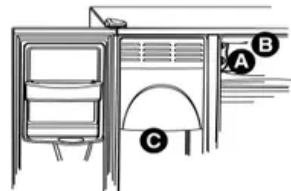

Troubleshooting



PROBLEM	POSSIBLE CAUSES	WHAT TO DO
Freezer control and lights are on, but compressor is not operating	Refrigerator is in defrost mode.	Normal operation. Wait 40 minutes to see if refrigerator restarts.
Temperature-controlled drawers are too warm	Control settings are too low.	See page 13 to adjust controls.
	Freezer controls are set too low.	See pages 8, 9 and 10 to adjust controls.
	Drawer is improperly positioned.	See pages 12-13 to verify drawer positioning.
Refrigerator does not operate	Refrigerator is not plugged in.	Plug in refrigerator.
	Dial control in freezer is set to OFF (select models).	See pages 8, and 9 to adjust controls.
	Touch temperature controls are set to “-” (select models).	See page 9 to adjust controls.
	Fuse is blown, or circuit breaker needs to be reset.	Replace any blown fuses. Check circuit breaker and reset, if necessary.
	Power outage has occurred.	Call local power company listing to report outage.
Refrigerator still won't operate	Refrigerator is malfunctioning.	Unplug refrigerator and transfer food to another refrigerator. If another refrigerator is not available, place dry ice in freezer

		<p>section to preserve food. Warranty does not cover food loss.</p> <p>Contact service for assistance.</p>
Food temperature is too cold	Condenser coils are dirty.	Clean according to the chart on page 25.
	Refrigerator or freezer controls are set too high.	See pages 8, 9 and 10 to adjust controls.
	Food is too close to upper left air inlet.	Relocate food.
Food temperature is too warm	Door is not closing properly.	Refrigerator is not level. See pages 4-5 for details on how to level your refrigerator.
		Check gaskets for proper seal. Clean, if necessary, according to the chart on page 25.
		Check for internal obstructions that are keeping door from closing properly (i.e. improperly closed drawers, ice buckets, oversized or improperly stored containers, etc.)
	Controls need to be adjusted.	See pages 8, 9 and 10 to adjust controls.
	Condenser coils are dirty.	Clean according to the chart on page 25.
	Rear air grille is blocked.	Check the positioning of food items in refrigerator to make sure grille is not blocked. Rear air grilles are located under crisper drawers.



	Door has been opened frequently, or has been opened for long periods of time.	Reduce time door is open. Organize food items efficiently to assure door is open for as short a time as possible.
	Food has recently been added.	Allow time for recently added food to reach refrigerator or freezer temperature.
Refrigerator has an odor	Odor producing foods should be covered or wrapped.	Clean according to instructions on page 25.
	The interior needs cleaning.	



Water droplets form on outside of refrigerator	Door gaskets are not sealing properly.	Clean according to the chart on page 25.
	Humidity levels are high.	Normal during times of high humidity.
	Controls require adjustment.	See pages 8, 9 and 10 to adjust controls.
Water droplets form on inside of refrigerator	Humidity levels are high or door has been opened frequently.	Reduce time door is open. Organize food items efficiently to assure door is open for as short a time as possible.
	Door gaskets are not sealing properly.	Clean according to the chart on page 25.
Refrigerator or ice maker makes unfamiliar sounds or seems too loud	Normal operation.	See page 29.
Temperature-controlled drawer and/or crisper drawer do not close freely	Contents of drawer, or positioning of items in the surrounding compartment could be obstructing drawer.	Reposition food items and containers to avoid interference with the drawers.
	Drawer is not in proper position.	See pages 12 and 13 for proper drawer placement.
	Refrigerator is not level.	See pages 4-5 for details on how to level your refrigerator.
	Drawer channels are dirty.	Clean drawer channels with warm, soapy water. Rinse and dry thoroughly.
Apply a thin layer of petroleum jelly to drawer channels.		



Refrigerator runs too frequently	Doors have been opened frequently or for long periods of time.	Reduce time door is open. Organize food items efficiently to assure door is open for as short a time as possible.
		Allow interior environment to adjust for period the door has been opened.
	Humidity or temperature in surrounding area is high.	Normal operation.
	Food has recently been added.	Allow time for recently added food to reach refrigerator or freezer temperature.
	Refrigerator is exposed to heat by environment or by appliances nearby.	Evaluate your refrigerator's environment. Refrigerator may need to be moved to run more efficiently.
	Condenser coils are dirty.	Clean according to the chart on page 25.
	Controls need to be adjusted.	See pages 8, 9 and 10 to adjust controls.
	Door is not closing properly.	Refrigerator is not level, see page 4-5, Leveling.
		Check for internal obstructions that are keeping door from closing properly (i.e. improperly closed drawers, ice buckets, oversized or improperly stored containers, etc.)
Door gaskets are not sealing properly.	Cleaning according to the chart on page 25.	



Ice and Water

PROBLEM	POSSIBLE CAUSES	WHAT TO DO
No indicator lights are lit on dispenser control	Freezer door is not closed.	Verify that freezer door is closed. Power is removed from the control when freezer door is opened.
	Refrigerator is not plugged in.	Plug in refrigerator.
	Fuse is blown, or circuit breaker needs to be reset.	Replace any blown fuses. Check circuit breakers for any tripped circuits.
	Power outage has occurred.	Call local power company listing to report outage.
	Refrigerator is in Sabbath Mode (select models).	See Sabbath Mode, page 18.
Ice or water are not dispensed when pads are pressed	Freezer door is not closed.	Verify that freezer door is closed. Power is removed from the control when freezer door is opened.
	Controls are in lock mode (select models).	See Dispenser Lock, page 18.
	Water tank is filling.	At initial use, there is an approximate one- to two-minute delay in dispensing while the internal water tank is filling.
	Ice maker has just been installed or a large amount of ice has been used.	Wait 24 hours for ice production to begin or for ice maker to restock after emptied.



	Water filter is clogged or needs to be changed.	Change water filter (see page 19).
Ice maker is not producing enough ice or ice is malformed	Ice maker has just been installed or a large amount of ice has been used.	Wait 24 hours for ice production to begin or for ice maker to restock after emptied.
	Water pressure is too low.	Low water pressure can cause valve to leak. Water pressure must be between 35 to 100 pounds per square inch to function properly. A minimum pressure of 35 pounds per square inch is recommended for refrigerators with water filters.
	Water filter is clogged or needs to be changed.	Change water filter (see page 19).
Ice maker is not producing ice	Ice maker arm is up.	Confirm ice maker arm is down. See Automatic Ice Maker, page 16.
	Household water supply is not reaching water valve.	See Connecting the Water Supply, pages 5 and 6.
	Copper tubing has kinks.	Turn off water supply and remove kinks. If kinks cannot be removed, replace tubing.
	Water pressure is too low.	Water pressure must be between 35 to 100 pounds per square inch to function properly. A minimum pressure of 35 pounds per square inch is recommended for refrigerators with water filters.



	Check freezer temperature.	See Temperature Controls, pages 8, 9 and 10 to adjust controls. Freezer must be between 0°to 2°F (-18°to -17°C) to produce ice.
	Ice bin is not installed properly.	See Ice Storage Bin, page 15.
	Improper water valve was installed.	See Connecting the Water Supply, pages 5 and 6. Self-piercing and 3/16" saddle valves cause low water pressure and may clog the line over time. The manufacturer is not responsible for property damage due to improper installation or water connection.
Water filter indicator light is red	Water filter needs to be replaced.	If filter is not available, replace with bypass filter. See Water Filter, page 19.
	Filter indicator sensor needs to be reset.	See Filter Status Indicator Light, page 18.



Ice forms in inlet tube to ice maker	Water pressure is low.	Water pressure must be between 35 to 100 pounds per square inch to function properly. A minimum pressure of 35 pounds per square inch is recommended for refrigerators with water filters.
	Saddle valve not open completely.	Open saddle valve completely.
	Freezer temperature is too high.	See Temperature Controls, pages 8, 9 and 10. Freezer temperature should be between 0°to 2°F (-18°to -17°C).
Refrigerator is leaking water	Plastic tubing was used to complete water connection.	The manufacturer recommends using copper tubing for installation. Plastic is less durable and can cause leakage. The manufacturer is not responsible for property damage due to improper installation or water connection.
	Improper water valve was installed.	See Connecting the Water Supply, pages 5 and 6. Self- piercing and 3/16" saddle valves cause low water pressure and may clog the line over time. The manufacturer is not responsible for property damage due to improper installation or water connection.
Water flow is slower than normal	Water pressure is low.	Water pressure must be between 35 to 100 pounds per square inch to function properly. A minimum pressure of 35 pounds per square inch is recommended for refrigerators with water filters.
	Saddle valve not open completely.	Open saddle valve completely.
	Improper water valve was installed.	See Connecting the Water Supply, pages 5 and 6. Self- piercing and 3/16" saddle valves cause low water pressure and may clog the line over



		time. The manufacturer is not responsible for property damage due to improper installation or water connection.
	Copper tubing has kinks.	Turn off water supply and remove kinks. If kinks cannot be removed, replace tubing.
	Water filter is clogged or needs to be changed.	Change water filter (see page 19).
	Water valve not opened completely.	Open water valve completely and check for leaks. The minimum flow at dispenser is approximately 10 fluid ounces in nine seconds with a new filter in place or approximately 10 fluid ounces in five seconds without a filter.
Dispenser water is not cold	Refrigerator has been recently installed.	Allow approximately 12 hours for water in holding tank to chill.
	Water supply in holding tank has been depleted.	
	Water has settled into water lines outside holding tank and has warmed to room temperature.	Discard first glass of water and refill.
Water appears cloudy	Air or air bubbles in water.	This is normal when first using the dispenser and will disappear with use.
Particles in water and/or ice cubes.	Carbon dust from water filter cartridge.	Initial water ejected through cartridge may contain harmless carbon dust flushed from cartridge. Particles are safe for consumption. Will disappear after the first few uses.
	Concentrations of minerals in water will form particles when water	Particles are not harmful and naturally occur in water supplies.

becomes frozen and melts.

Warning

This content is compiled from multiple sources and is provided for reference purposes only. It may not be complete or fully applicable to all situations. If you are unable to resolve your issue, please contact the product manufacturer or an authorized service provider for official support.

Document generated by [ManualsFile](#)

