

## SETTING UP YOUR OVEN

### NAMES OF OVEN PARTS AND ACCESSORIES

Remove the oven and all materials from the carton and oven cavity. Your oven comes with the following accessories:

- Glass tray 1
- Turntable ring 1
- Instruction Manual 1

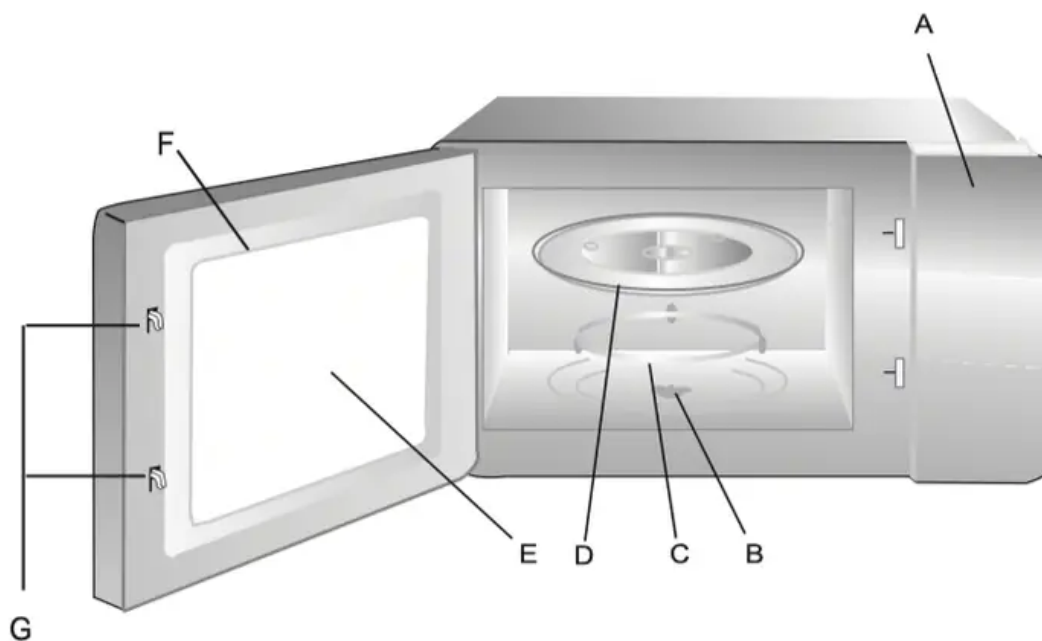

- A. Control panel
- B . Turntable shaft
- C. Turntable ring
- D. Glass tray
- E . Observation window
- F . Oven Door
- G. Safety interlock system

## TURNTABLE INSTALLATION

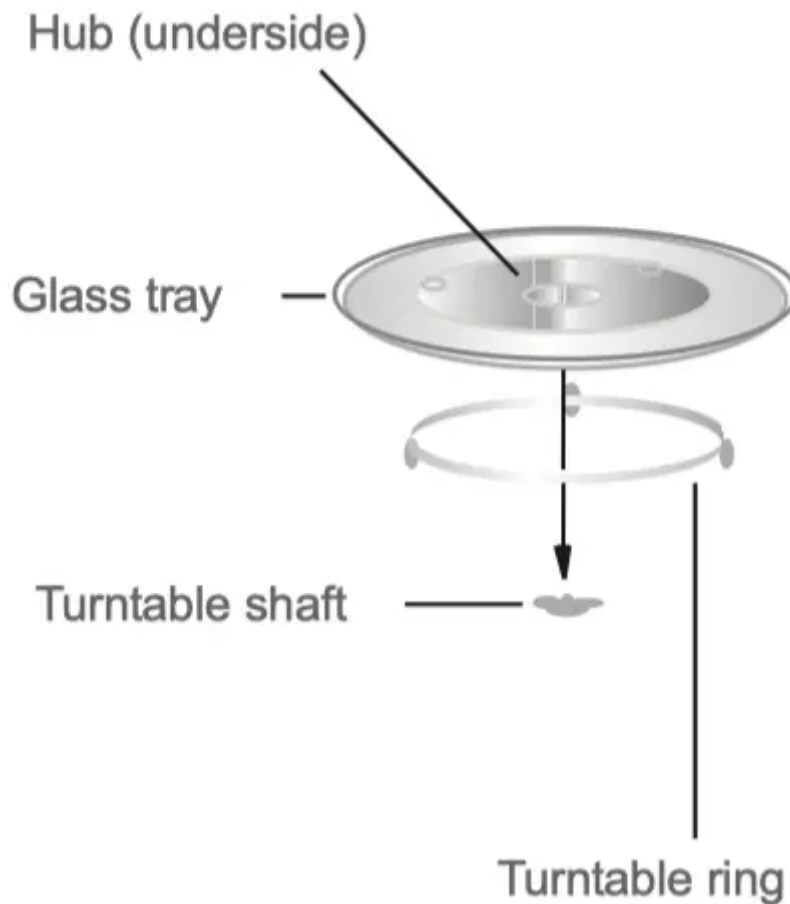

- a. Never place the glass tray upside down. The glass tray should never be restricted.
- b. Both glass tray and turntable ring must always be used during cooking.
- c. All food and containers of food are always placed on the glass tray for cooking.

## COUNTERTOP INSTALLATION

Remove all packing material and accessories. Examine the oven for any damage such as dents or broken door. Do not install if oven is damaged.

Cabinet: Remove any protective film found on the microwave oven cabinet surface. Do not remove the light brown Mica cover that is attached to the oven cavity to protect the magnetron.

## INSTALLATION

1. Select a level surface that provide enough open space for the intake and/or outlet vents.

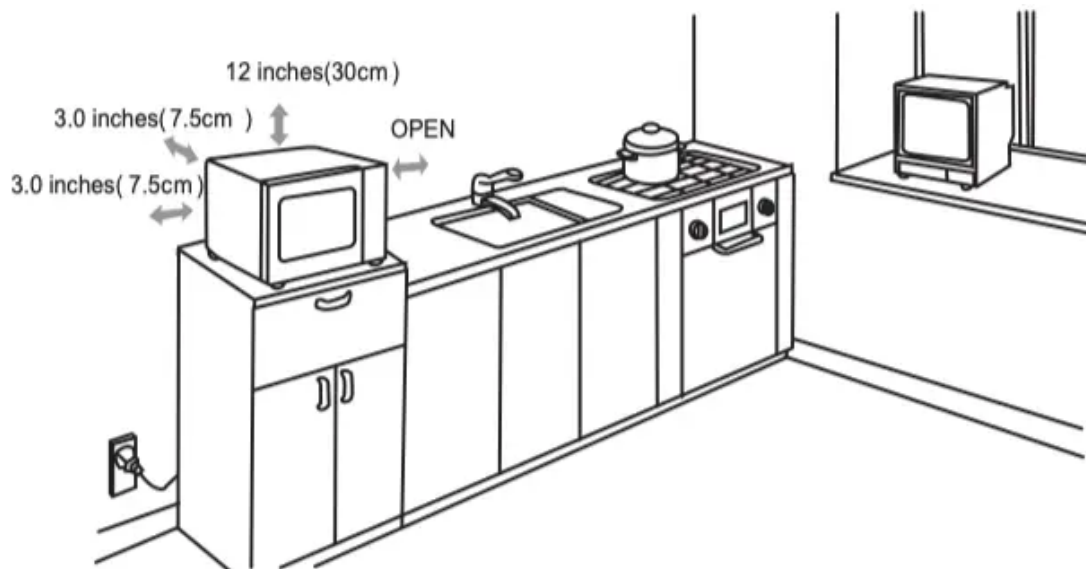

A minimum clearance of 3.0 inches (7.5cm) is required between the oven and any adjacent walls. One side must be open.

- (1) Leave a minimum clearance of 12 inches (30cm) above the oven.
  - (2) Do not remove the legs from the bottom of the oven.
  - (3) Blocking the intake and/or outlet openings can damage the oven.
  - (4) Place the oven as far away from radios and TV as possible. Operation of microwave oven may cause interference to your radio or TV reception.
2. Plug your oven into a standard household outlet. Be sure the voltage and the frequency is the same as the voltage and the frequency on the rating label.

## **WARNING**

Do not install oven over a range cooktop or other heat-producing appliance. If installed near or over a heat source, the oven could be damaged and the warranty would be void.

# OPERATION

## CONTROL PANEL AND FEATURES

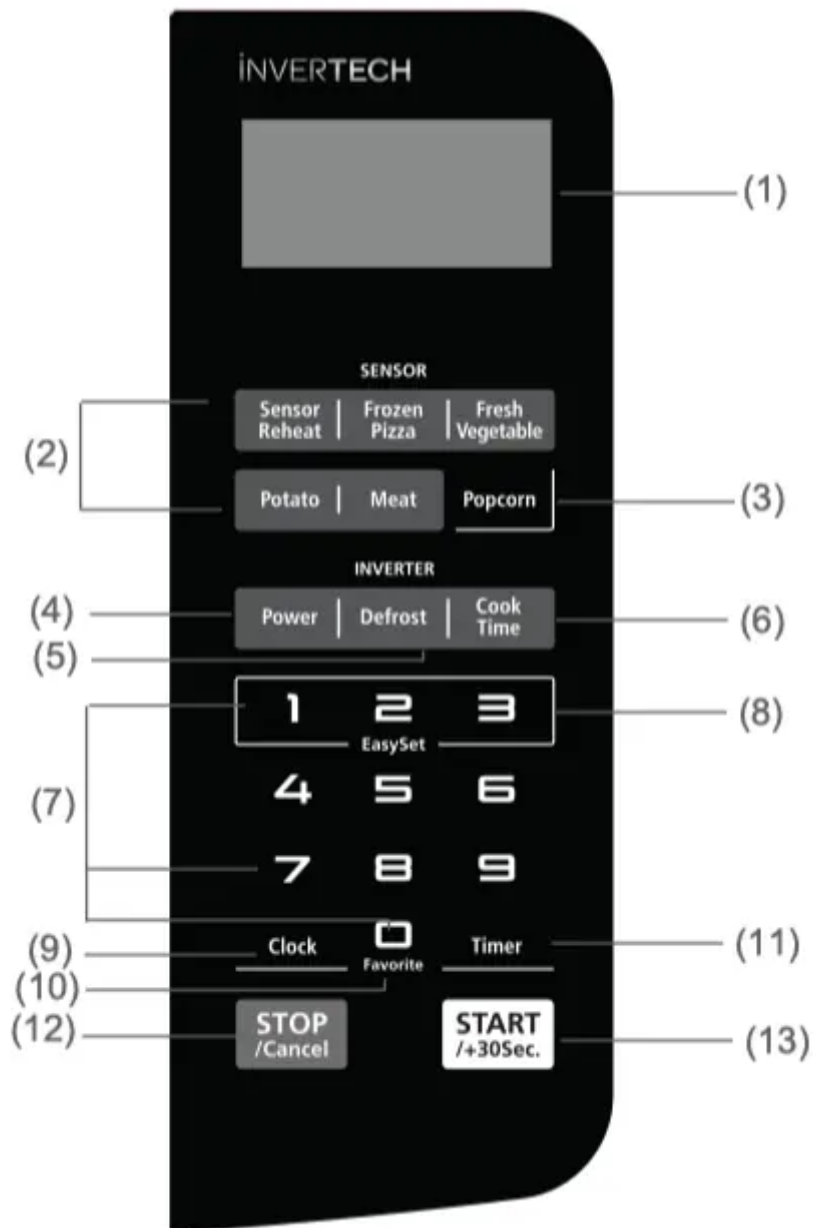

(1) Display Screen

(2) Sensor Cook Menu (Sensor Reheat, Frozen Pizza, Fresh Vegetable, Potato and Meat)

(3) Popcorn Menu

(4) Power Level

(5) Defrost

(6) Cook Time

(7) Number Pads

(8) Quick Start Cooking

(9) Clock

(10) Favorite

(11) Timer

(12) STOP Cancel Hold 3 sec: Before cooking starts, press to clear all previous settings. During cooking, press once to stop oven; press twice to stop oven and clear all settings.

(13) START ADD 30 SEC

## 1. POWER LEVELS

Ten power levels are available.

Prior to or during cooking, press Power and "PL10" will display. Then press number pads to select a different power level.

Level	10	9	8	7	6	5	4	3	2	1
Power	100%	90%	80%	70%	60%	50%	40%	30%	20%	10%
Display	PL10	PL 9	PL 8	PL 7	PL 6	PL 5	PL 4	PL 3	PL 2	PL 1

## 2. CLOCK SETTING

When the microwave oven is plugged into an outlet, "0:00" will display.

- (1) Press Clock once, "00:00" will appear in the display.
- (2) Press the number pads to enter the current clock time. For example, if the time is now 10:12, press " 1, 0, 1, 2 " in order.
- (3) Press Clock to finish clock setting, " : " will flash and the numbers will appear as a clock time in the display.

### NOTE:

- If the numbers entered are not within the range between 1:00 to 12:59, the setting will not be accepted until valid numbers are entered.

- In the process of setting clock, if the  pad is pressed or if there is no operation within 1 minute, the display will automatically return to the previous clock setting.

## 3. KITCHEN TIMER



- (1) Press Timer once, "00:00" will appear in the display.

(2) Press the number pads to enter the time amount. The maximum amount of time that can be entered is 99 minutes, 99 seconds.

(3) Press  to confirm setting, and the timer will start to count down.

(4) When the time arrives, the oven will beep 5 times.

**Note:**

- The Kitchen Timer setting is different from the Clock setting; it is simply a timer.
- During the Kitchen Timer function, no cooking function can be set into operation.
- Kitchen Timer amount cannot be increased by pressing .
- Press  will cancel the Timer countdown.

#### 4. MICROWAVE COOK

(1) Press Cook Time , "00:00" will appear in the display.

(2) Press number pads to enter the cooking time. The maximum cooking time is 99 minutes, 99 seconds.

(3) Press Power, PL10 will flash. Press number pads 0 through 9 to select a different power level if desired. See the POWER LEVEL table above.

(4) Press  to start cooking. The remaining cooking time will display.

**Example :** To cook the food with 50% microwave power for 15 minutes.

- a. Press Cook Time , "00:00" will display.
- b. Press "1, 5, 0, 0" in order for 15:00 to appear in the display.
- c. Press Power once , then press "5" to select 50% microwave power.
- d. Press  to start cooking. Buzzer sounds once. The remaining cooking time will display.

**NOTE:**



In the process of setting, if the  pad is pressed or if there is no operation within 1 minute, the oven will automatically return to display the clock.

## 5. ONE TOUCH START

(1) Instant cooking at 100% power level and 1 to 3 minutes cooking time can be started by pressing number pads 1 to 3. Press  to increase the cooking time by 30 seconds with each press. The maximum cooking time is 99 minutes, 99 seconds.

(2) Instant cooking at 100% power level and 30 seconds cooking time can be started by pressing . Each repeated press will increase cooking time by 30 seconds. The maximum cooking time is 99 minutes, 99 seconds.

### NOTE:

- Time can also be added in 30 second increments by pressing  during Microwave Cooking, Time Defrost and Multi-stage Cooking.
- Time cannot be added by pressing  during Weight Defrost and Kitchen Timer functions.

## 6. WEIGHT DEFROST FUNCTION

(1) Press Defrost once, "WEIGHT" will display.

(2) Press number pads to input weight to be defrosted. Input the weight range between 0.1 to 6.0 lbs.

(3) If the weight input is not between 0.1 to 6.0lbs, the input will be invalid. A beep will sound and the unit will not work until valid numbers are entered.

(4) Press  to start defrosting and the cooking time remaining will be displayed.

## 7. TIME DEFROST

(1) Press Defrost twice, "TIME" will appear in the display.

(2) Press the number pads to input the defrost time. The time arrange is 00:01-99:99.

(3) The default microwave power is power level 3.

(4) Press  to start defrost cooking. And the remaining defrost time will display.



## 8. POPCORN



(1) Press Popcorn, "1.75" will appear in the display.

(2) Press Popcorn two more times to choose the weight, "3.0" and "3.5" will display in order.

(3) Press  to cook. The remaining time will display. Oven beeps 5 times when cooking finish.

## 9. Sensor Cooking

1) In waiting state, press the relevant menu key in the sensor cook, put the food in the oven. "SENSOR REHEAT" , "FROZEN PIZZA" , "FRESH VEGETABLE" , "POTATO" and "MEAT" will display twice in turn .The " " and the " " will be lighted.

2) Press " " to start sensor reheat function and no need to set time. The " " and the " " will flash. If the sensor receive the humidity signal, the buzzer will sound 2 beeps, and the remaining time will display. Or the screen will show "S-01"、 "S-02"... "S-05".

Note:

1) When cooking or reheating food, you should do these in order to have the best effect.

- a. The room temperature cannot be over 35 degrees.
- b. The weight of food must be more than 110g (4 Oz).
- c. The cavity, glass tray and utensils must kept drying before putting the food in.
- d. The reheat food can be covered with the lid. But the lid must has vent hole in order to emanate the steam. Sealed utensil is forbidden.
- e. If the cavity is too hot, the sensor cook can not be started.

2) During cooking process, following points must be done.

- a. Keep the door close when the remaining time is not displays or the buzzer does not sound twice.
- b. When the buzzer sound twice , the time will count down and display the remaining time, you can open the door to mix the food up ,turn over or replace the food. And then go on the next operation.

3) Please leave the food alone for a while after cooking have been finished.

4) During sensor cooking process, if the time not count down, please do not open the oven

door or press " " key. Otherwise, the sensor will make mistakes.

5) After 35 seconds sensor cooking, the buzzer sound 1 beep to start self-checking. If the sensor do not work, the oven will go back to waiting state after 40seconds.

## Sensor Cook Chart

Menu	Weight	Initial Temp.	Additional Instructions
<b>S-01 Sensor Reheat</b>	8~12 Oz	5 degrees	Reheat food is dinner plate. When sensor time finish, Cooking time counts down. Now you can mix it and then continue reheating.
<b>S-02 Frozen Pizza</b>	6~12 Oz (170~340g)	minus 18 degrees	If the weight is over 12 OZ, please set the additional cooking time manually.
<b>S-03 Fresh Vegetable</b>	4~16Oz (110~450g)	Room Temp.	All pieces should be the same size. Wash thoroughly, add 15ml water per 125g vegetables, and cover with a lid or vented plastic wrap. When cooking time counts down. Press " STOP/CANCEL " to pause and open the oven door to mix and then continue to cook.
<b>S-04 Potato</b>	1~4 Units (6~8Oz each one)	Room Temp.	Pierce each potato with a fork 6 times around it's surface. Place potatoes around the edge of a paper-towel-lined turntable. Do not cover. If additional time is needed, continue to cook manually. Please let stand for 5 minutes in the oven after finishing to avoid burning.
<b>S-05 Meat</b>	8~24 Oz (225~680g)	5 degrees	Break apart in glass bowl or colander. Cover with lid or vented plastic wrap. Juices should be clear when done, Drain. When cooking time counts down. Press "STOP/ CANCEL" to pause and open the oven door to mix and then continue to cook.

## Sensor Reheat Menu

1) In waiting states, and put the food into the microwave oven. Press "SENSOR REHEAT" "S-01" is displayed.

2) Press "  " to start sensor reheat function and no need to set time.

3) The sensor will sound twice when the steaming was be emanated. The surplus time will displays, the buzzer will sound 5 beeps when finishing and the oven will turn back to the waiting states.

**Note:**

1) Food to be avoided in sensor reheating.

- a. Bread and other dry food, such as biscuit, cake.
- b. For raw or uncooked foods.
- c. Beverage and frozen food.

2) The oven cannot cook automatically when the temperature of the oven cavity is high.

3) The reheat food can be covered with the lid. And the lid must has venthole in order to emanate the steam. Sealed utensil is forbidden.

4) During sensor cooking process, please do not open the oven door or press "  " key. Otherwise, the sensor will make mistakes.

Casseroles- Add 3 to 4 tablespoons of water, cover with lid or vented plastic wrap.

5) The sensor reheat has different request for different food.

Stir when time appears in the display window.

Canned foods- Empty contents into casserole dish or serving bowl, cover dish with lid or vented plastic wrap. After reheating, let stand for a few minutes.

Plate of food- Arranged food on plate; top with butter, gravy, etc. Cover with lid or vented plastic wrap. After reheating, let stand for a few minutes.

## 10. MEMORY FUNCTION



(1) Press Favorite to program and choose up to three cooking procedures. Each procedure will be indicated by 1, 2 or 3 in the display.

(2) Press Favorite until your desired procedure number appears in the display. Press

 to begin it. A maximum of two cooking stages can be set for each procedure.

(3) To program a procedure, follow the steps listed below. Example: Cook food at 80% Power Level for 3 minutes and 20 seconds; save as memory 2.

- a. Press Favorite twice; screen displays 2.
- b. Press Cook Time , then press "3" , "2" and "0" in order.
- c. Press Power once, then press "8" for "PL 8" to display.

d. Press  to save the procedure. Oven beeps once. Or press  twice directly to save and start cooking.

e. To choose the procedure from the memory list, press Favorite twice. Screen will display "2". Press  to run procedure.

**NOTE:**

Auto Menu cannot be set in Memory function.

## 11. Multi-Stage Cooking

At most 2 stages can be set for cooking. If one stage is Defrost, it will automatically set to be the first stage.

**NOTE:** Auto Menu cannot be set in Multi-stage Cooking.

**EXAMPLE:** 80% Power Level for 5 minutes followed by 60% Power Level for 10 minutes; saved as memory 3.

- a. Press Favorite 3 times, screen displays 3.
- b. Press Cook Time, then press "5" , "0" and "0" to set first stage cook time.
- c. Press Power once, then press "8" to choose 80% first stage cooking power.
- d. Press Cook Time again, then press "1" , "0" , "0" and "0" to set second stage cook time.
- e. Press Power again, then press "6" to choose 60% second stage cooking power.

f. Press  to immediately start multi-stage cooking.

g. To choose the procedure from the memory list, press Favorite three times. Screen will display "3"; press  to run procedure.

**NOTE:**

If you do not want to save a particular multi-stage program as a procedure, do not press Favorite

as the first step. Press  after programming both stages.

## 12. LOCK FUNCTION FOR CHILDREN

Lock: In waiting state, press "  " for 3 seconds, there will be a long "beep" denoting the entering into the children-lock state; meanwhile, oven will display "LOCKED". 2 seconds later, the screen will display " L " and the current time, if the clock has been set.

Lock quitting: In locked state, press "  " for 3 seconds, there will be a long "beep" denoting that lock is released.

### **13. INQUIRING FUNCTION**

(1) In cooking state, press " CLOCK ", the screen will display clock for three seconds, if the clock has been set.

(2) In the microwave cooking state, press " POWER " to inquire microwave power level, and the current microwave power will be displayed. After three seconds, the oven will turn back to the previous state. In multi-stage state, the inquiring way can be done by the same way as above.

### **14. COOKING END REMINDING FUNCTION**

When the cooking is over, the buzzer will sound 5 "beep" to alert user the cooking is finished. The screen displays " FINISH".

## **MAINTENANCE**

### **TROUBLESHOOTING**

Check your problem by using the chart below and try the solutions for each problem.

<b>TROUBLE</b>	<b>Possible Cause</b>	<b>Possible Remedy</b>
<b>Oven will not start</b>	<ul style="list-style-type: none"> <li>a. Electrical cord for oven is not plugged in.</li> <li>b. Door is open.</li> <li>c. Wrong operation is set.</li> </ul>	<ul style="list-style-type: none"> <li>a. Plug into the outlet.</li> <li>b. Close the door and try again.</li> <li>c. Check instructions</li> </ul>
<b>Arcing or sparking</b>	<ul style="list-style-type: none"> <li>a. Materials to be avoided in microwave oven were used.</li> <li>b. The oven is operated when empty.</li> <li>c. Spilled food remains in the cavity.</li> </ul>	<ul style="list-style-type: none"> <li>a. Use microwave-safe cookware only.</li> <li>b. Do not operate with oven empty.</li> <li>c. Clean cavity with wet towel.</li> </ul>
<b>Unevenly cooked foods</b>	<ul style="list-style-type: none"> <li>a. Materials to be avoided in microwave oven were used.</li> <li>b. Food is not defrosted completely.</li> <li>c. Cooking time, power level is not suitable.</li> <li>d. Food is not turned or stirred.</li> </ul>	<ul style="list-style-type: none"> <li>a. Use microwave-safe cookware only.</li> <li>b. Completely defrost food.</li> <li>c. Use correct cooking time, power level.</li> <li>d. Turn or stir food.</li> </ul>
<b>Overcooked foods</b>	Cooking time, power level is not suitable.	Use correct cooking time, power level.
<b>Undercooked foods</b>	<ul style="list-style-type: none"> <li>a. Materials to be avoided in microwave oven were used.</li> <li>b. Food is not defrosted completely.</li> <li>c. ven ventilation ports are restricted.</li> <li>d. Cooking time, power level is not suitable.</li> </ul>	<ul style="list-style-type: none"> <li>a. Use microwave-safe cookware only.</li> <li>b. Completely defrost food.</li> <li>c. Check to see that oven ventilation ports are not restricted.</li> <li>d. Use correct cooking time, power level</li> </ul>
<b>Improper defrosting</b>		

	<ul style="list-style-type: none"> <li>a. Materials to be avoided in microwave oven were used.</li> <li>b. Cooking time, power level is not suitable.</li> <li>c. Food is not turned or stirred.</li> </ul>	<ul style="list-style-type: none"> <li>a. Use microwave-safe cookware only.</li> <li>b. Use correct cooking time, power level.</li> <li>c. Turn or stir food</li> </ul>
<b>Sensor cooked foods not properly cooked</b>	<ul style="list-style-type: none"> <li>a. Cover or lid on food not vented.</li> <li>b. Door opened before sensor-detected cooking time appears in display.</li> </ul>	<ul style="list-style-type: none"> <li>a. Cover or lid over food must contain vent hole for escaping steam.</li> <li>b. Do not open door to stir or turn food before sensor-detected cooking time appears in display.</li> </ul>

**Warning**

This content is compiled from multiple sources and is provided for reference purposes only. It may not be complete or fully applicable to all situations. If you are unable to resolve your issue, please contact the product manufacturer or an authorized service provider for official support.

