







Assembly

			
<p>1 Insert handle into wand until it clicks in place.</p>	<p>2 Insert wand into the spine until it clicks in place.</p>	<p>3 Insert hose into canister until it clicks in place.</p>	<p>4 Place tools onboard.</p>

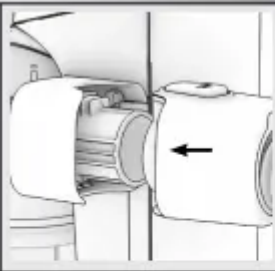
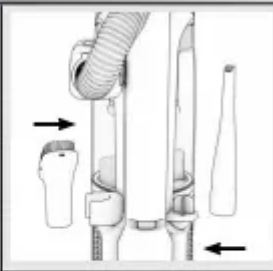



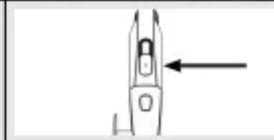

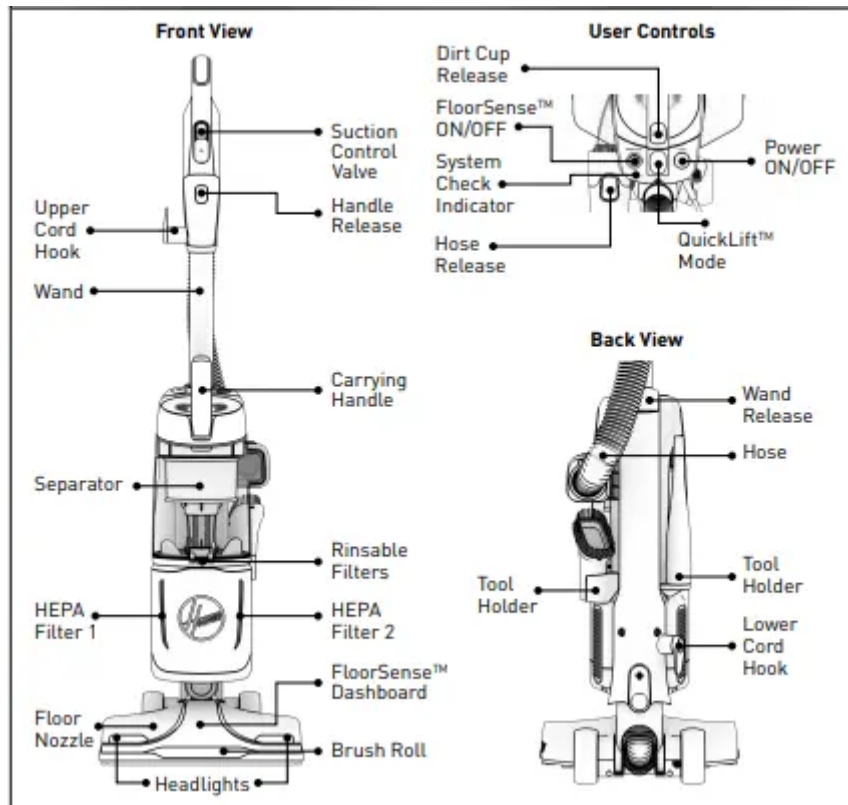
User Controls

			
<p>1 Power the unit ON/OFF.*</p>	<p>2 Power FloorSense™ ON/OFF.*</p>	<p>3 System Check Indicator* Refer to the Maintenance section or the Hoover App for directions on how to remove clogs.</p>	<p>4 Suction Control Valve* If vacuum is difficult to push, open the Suction Control Valve on the handle.</p> <p style="text-align: right;">*See page 6 for location of features</p>

Getting to Know Your Hoover® REACT™ Upright





Available Tools and Accessories***

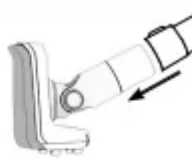

<p>Crevice Tool: Great for cleaning in tight spaces and hard-to-clean corners.</p>		<p>Deluxe Crevice Tool: Rubberized tip that protects furniture when cleaning tight spaces. XL Crevice Tool: Extra-long, flexible tip that reaches into hard-to-clean spaces.</p>
<p>Dusting Brush: Delicate bristles that gently clean fine dust.</p>		<p>Flexible Dusting Brush: Dust hard-to-reach surfaces such as fan blades and blinds.</p>
<p>Turbo Tool: Easily clean furniture, stairs, upholstery and more.</p>		<p>Pet Turbo Tool: Uniquely designed to remove stubborn pet hair from furniture, stairs, upholstery and more.</p>
<p>Upholstery Tool: Deep clean couches, curtains and pillows.</p>		<p>Pet Upholstery Tool: Uniquely designed to remove stubborn pet hair from couches, curtains and pillows.</p>
<p>Baseboard Duster: Uniquely designed to effortlessly clean fine dust from baseboards.</p>		
<p>Accessory Bag: Use to store tools.</p>		

Directions for Use: Baseboard Duster***

Uniquely designed to effortlessly clean fine dust from baseboards

			
<p>1 Align the cleaning pad to the bottom of the tool by pressing firmly.</p>	<p>2 Remove wand from vacuum spine and attach tool to the end of the wand.</p>	<p>3 Detach canister from spine and use in Quick Lift™ Mode.</p>	<p>4 Align the Baseboard Duster with pad against the baseboard and wheels touching the floor, then glide along baseboard.</p>

Directions for Cleaning: Baseboard Duster***



			
1 Remove tool from wand.	2 Remove cleaning pad from Baseboard Duster by pulling gently from one edge.	3 Hand wash only with warm water and mild detergent.	4 Tumble dry on low.

Hoover® FloorSense™ Technology

Hoover® REACT™ with FloorSense™ technology automatically optimizes cleaning performance on carpet and hard floors. On carpet, FloorSense™ automatically increases brush roll speed to lift deep-down embedded dirt. On hard floors, FloorSense™ automatically slows the brush roll to prevent scattering of dirt across the floor.

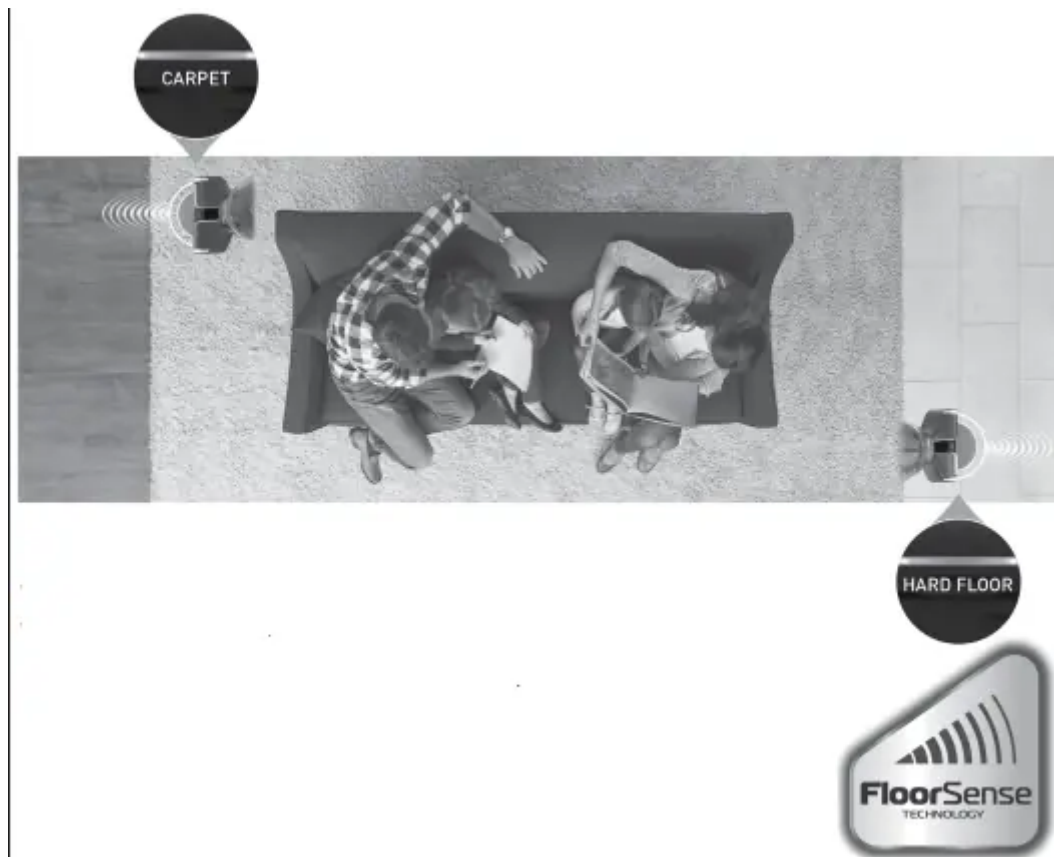
The FloorSense™ Dashboard displays useful functions of your vacuum. When FloorSense™ is active, lights on the dashboard will pulse when sensing floor type. Once FloorSense™ has determined the optimal setting for your floor type, you will see CARPET or HARD FLOOR illuminated on the dashboard.



		
<p>1 When cleaning CARPET, FloorSense™ automatically increases brush roll speed to lift deep-down embedded dirt.</p>	<p>2 On HARD FLOOR, FloorSense™ automatically slows the brush roll to prevent scattering of dirt across the floor.</p>	<p>3 BRUSH ROLL will be displayed when the brush roll is jammed or overloaded. Refer to the Maintenance section or the Hoover App for directions on how to clean the brush roll.</p>

Tip - To allow FloorSense™ to determine floor type and optimize brush roll speed automatically; ensure the FloorSense™ control is in the ON position.



Using the Hoover App

Download the Hoover App to:

1. Register your new vacuum
2. Customize FloorSense™ settings
3. Receive system maintenance reminders
4. Access tips and tricks



Using Your Hoover® REACT™ Upright

Upright Mode

1. Step on nozzle and pull handle back.
2. Turn ON vacuum.
3. Allow FloorSense™ to detect floor type and automatically adjust settings.



QuickLift™ Mode

1. Press wand or handle release and pull handle up.
2. Attach cleaning accessory to the end of the wand or handle.
3. Detach canister from vacuum spine by pressing QuickLift™ Mode.
4. Turn ON vacuum.

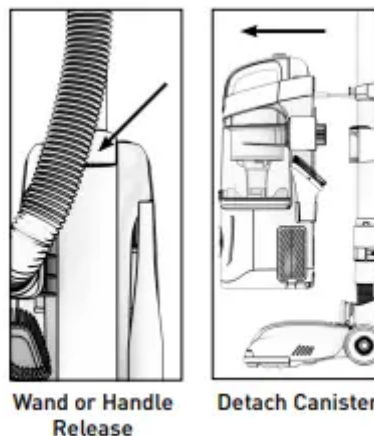

Maintenance

Any other servicing should be done by an authorized service representative. If appliance is not working as it should, has been dropped, damaged, left outdoors, or dropped into water, take it to a service center prior to continuing use.

Hoover® REACT™ vacuums should have regular maintenance checks to maintain optimal performance and suction. Refer to this manual or your Hoover App to learn how to maintain your vacuum.

Notice: A Thermal Protector has been designed into your cleaner to protect it from overheating. When the Thermal Protector activates, the cleaner will stop running. If this happens proceed as follows:

1. Turn cleaner OFF and unplug it from the electrical outlet.
2. Empty the dirt cup.
3. Inspect the nozzle inlet, hose connector, hose, dirt cup inlet, cyclonic filter, rinsable filters and HEPA filters for any obstructions. Clear obstructions if present.
4. When cleaner is unplugged and motor cools off for 30 minutes, the Thermal Protector will deactivate and cleaning may continue.

If the Thermal Protector continues to activate after following the above steps, your cleaner needs servicing. Refer to the Warranty section in the user manual for servicing information.

Emptying the Dirt Cup:

1. Remove dirt cup by pressing the dirt cup release button.
2. Hold dirt cup over a trash can and press the dirt cup trap door release to empty the dirt cup.

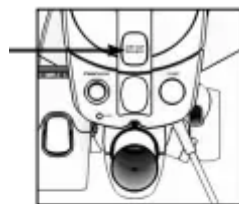

Dirt Cup Release

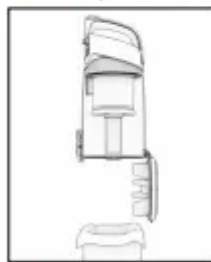

Empty Dirt Cup

Cleaning the Filters:

Rinsable Filters

1. Remove dirt cup by pressing the dirt cup release button.
2. Access the rinsable filters under the dirt cup.
3. To remove, pull up on the tab provided.
4. Rinse under running water until all dirt is out of the filters.
5. Let your filters dry for 24 hours before replacing into vacuum.

Tip - Replace filters when heavily discolored. Make sure filters are flush to the bottom of the filter housing.

HEPA Filters

Hoover® REACT™ products have 2 HEPA filters. Refer to Getting to Know Your Hoover® REACT™ QuickLift™ for location.

1. Locate HEPA filters on each side of the vacuum below the dirt cup.
2. Unscrew the vent cover located on the bottom of the canister to access filters.
3. Remove filters and tap on side of trash can to release excess dirt.

Tip - DO NOT RINSE HEPA FILTERS. Replace filters when heavily discolored. Do not use your vacuum without all of the filters in place.

Cleaning and Maintaining the Brush Roll:

1. To access the brush roll, unscrew the nozzle guard from the nozzle.
2. Remove brush roll by pulling it up and out from the vacuum belt.
3. Remove any hair or blockages.
4. Replace brush roll and nozzle guard.

Tip - Rotate brush roll manually to ensure the belt is properly installed. Vacuum is equipped with an automatic brush roll shutoff in the event of overload or jam. Check for obstructions in the brush roll area and remove any obstructions. When obstructions are cleared, resume cleaning as normal.

LUBRICATION: The motor and brush roll are equipped with bearings which contain sufficient lubrication for their lifetime. The addition of lubrication could cause damage. Do not add lubricant to motor or brush roll.

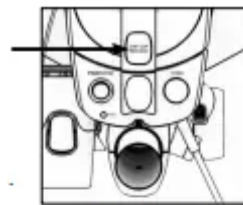

Dirt Cup Release

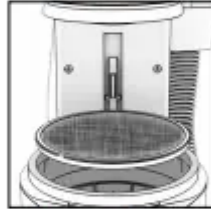

Remove Filter

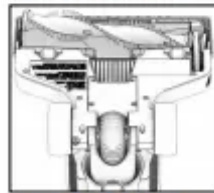





Clean Brush Roll

Removing System Clogs

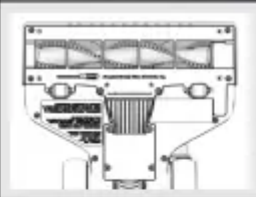
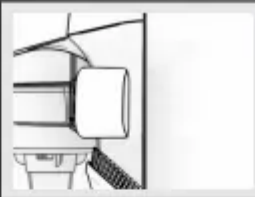
If your vacuum is losing suction, check and remove any clogs.

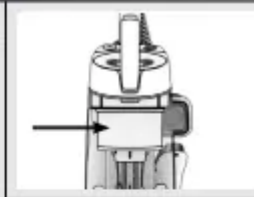
Check for clogs in the areas highlighted below.

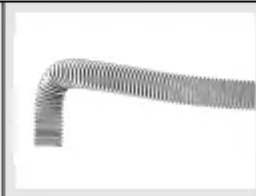
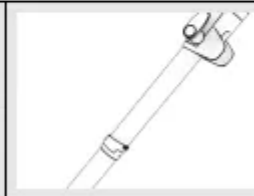
			
1 Nozzle inlet	2 Hose connector	3 Dirt cup inlet	4 Cyclonic filter
			
5 Rinsable filters	6 HEPA filters	7 Hose	8 Wand

Troubleshooting Guide

Any other servicing should be done by an authorized service representative. If appliance is not working as it should, has been dropped, damaged, left outdoors, or dropped into water, take it to a service center prior to continuing use.

Vacuum will not turn ON.

Always be sure to plug it in firmly. A Thermal Protector may have been activated

- unplug and let vacuum cool for 30 minutes. If this does not work, there may be no voltage in the wall plug. Check fuse or breaker in home. If there is a blown fuse or tripped breaker, replace fuse or reset breaker in home.

My vacuum is hard to push.

Open the Suction Control Valve near the handle by sliding the valve up.

My vacuum is losing suction.

Be sure to empty the dirt cup if it is full. You may have a clogged filter. Your filter should be rinsed every 4-6 uses. Refer to the Maintenance section or the Hoover App for directions on how to clean your filters. If problem persists, you may have a clog in the system. Refer to Maintenance in the user manual for directions on removing clogs.

My brush roll is not spinning or FloorSense™ dashboard is not displaying correctly.

1. Unplug and remove any hair or other blockages around the brush roll if FloorSense™ is displaying "HARD FLOOR" while on carpet.
2. Clean filters. Refer to the Maintenance section or the Hoover App for directions on how to clean filters.
3. Check for clogs in the system. Refer to the Maintenance section or the Hoover App for directions on how to remove clogs.
4. Resume normal operation and FloorSense™ will reset.

I can't connect my vacuum to the Hoover App.

Vacuum must be powered ON to connect to the Hoover App. For more troubleshooting or FAQ's please call: 1-877-839-2046

Important Safety Instructions

- Fully assemble before operating.
- Operate vacuum only at voltage specified on data label on bottom of the vacuum canister.
- Do not leave appliance when plugged in. Unplug from outlet when not in use and before cleaning or servicing.
- Do not use outdoors or on wet surfaces.
- Do not allow to be used as a toy. Not intended for use by children age 12 and under. Close attention is necessary when used near children. To avoid injury or damage,

keep children away from product, and do not allow children to place fingers or other objects into any openings.

- Use only as described in this manual. Use only manufacturer's recommended attachments and products.
- Do not use with damaged cord or plug. If appliance is not working as it should, has been dropped, damaged, left outdoors, or dropped into water, take it to a service center prior to continuing use.
- Do not pull or carry by cord, use cord as a handle, close a door on a cord or pull cord around sharp edges or corners. Do not place product on cord. Do not run appliance over cord. Keep cord away from heated surfaces.
- Do not unplug by pulling on cord. To unplug, grasp the plug, not the cord.
- Do not handle plug or appliance with wet hands.
- Do not put any object into openings. Do not use with any opening blocked. Keep free of dust, lint, hair and anything that may reduce air flow.
- Keep hair, loose clothing, fingers and all parts of body away from openings and moving parts.
- Turn off all controls before unplugging.
- Use extra care when cleaning on stairs. To avoid personal injury or damage, and to prevent the vacuum from falling, always place vacuum at the bottom of stairs on floor. Do not place vacuum on stairs or furniture, as it may result in injury or damage. When using tools, always ensure handle is in upright position.
- Do not use to pick up flammable or combustible liquids, such as gasoline or fine wood shavings, or use in areas where they may be present.
- Do not pick up anything that is burning or smoking, such as cigarettes, matches or hot ashes.
- Unplug this appliance before connecting the air-powered Turbo Tool.
- Do not use without dirt cup and/or filters in place.
- Always turn off this appliance before connecting or disconnecting the hose or motorized nozzle.

Warning

This content is compiled from multiple sources and is provided for reference purposes only. It may not be complete or fully applicable to all situations. If you are unable to resolve your issue, please contact the product manufacturer or an authorized service provider for official support.

