

Maintenance

Cleaning

Clean the oven regularly to prevent impurities from building up on or inside the oven. Also pay special attention to the door, door sealing, and turntable and roller ring (applicable models only).

If the door won't open or close smoothly, first check if the door seals have built up impurities. Use a soft cloth in soapy water to clean both the inner and outer sides of the oven. Rinse and dry well.

To remove stubborn impurities with bad smells from inside the oven

1. With an empty oven, put a cup of diluted lemon juice on the centre of the turntable.
2. Heat the oven for 10 minutes at max power.
3. When the cycle is complete, wait until the oven cools down. Then, open the door and clean the cooking chamber.

To clean inside swing-heater models

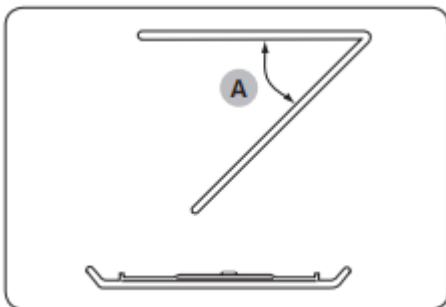

- To clean the upper area of the cooking chamber, lower the top heating element by 45° (A) as shown. This will help clean the upper area. When done, reposition the top heating element.

CAUTION

- Keep the door and door sealing clean and ensure the door opens and closes smoothly. Otherwise, the oven's lifecycle may be shortened.
- Take caution not to spill water into the oven vents.
- Do not use any abrasive or chemical substances for cleaning.
- After each use of the oven, use a mild detergent to clean the cooking chamber after waiting for the oven to cool down.

Replacement (repair)

WARNING: This oven has no user-removable parts inside. Do not try to replace or repair the oven yourself.

- If you encounter a problem with hinges, sealing, and/or the door, contact a qualified technician or a local Samsung service centre for technical assistance.
- If you want to replace the light bulb, contact a local Samsung service centre. Do not replace it yourself.
- If you encounter a problem with the outer housing of the oven, first unplug the power cord from the power source, and then contact a local Samsung service centre.

Care against an extended period of disuse

- If you don't use the oven for an extended period of time, unplug the power cord and move the oven to a dry, dust-free location. Dust and moisture that builds up inside the oven may affect the performance of the oven.

Oven features

Oven

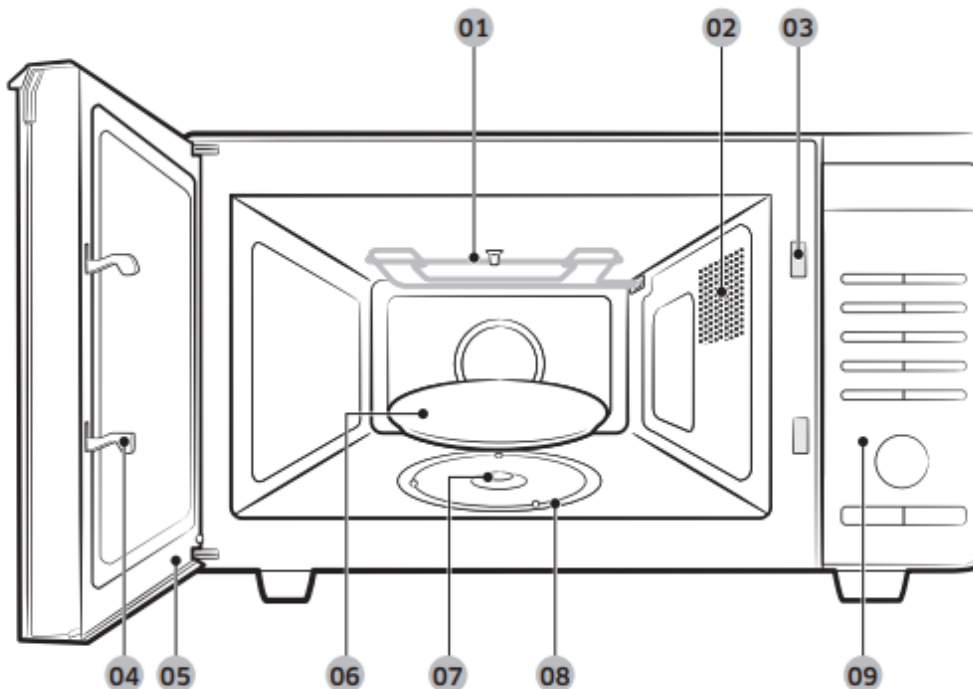

01. Heating element

02. Ventilation holes

03. Safety interlock holes

04. Door latches

05. Door

06. Turntable

07. Coupler

08. Roller ring

09. Control panel

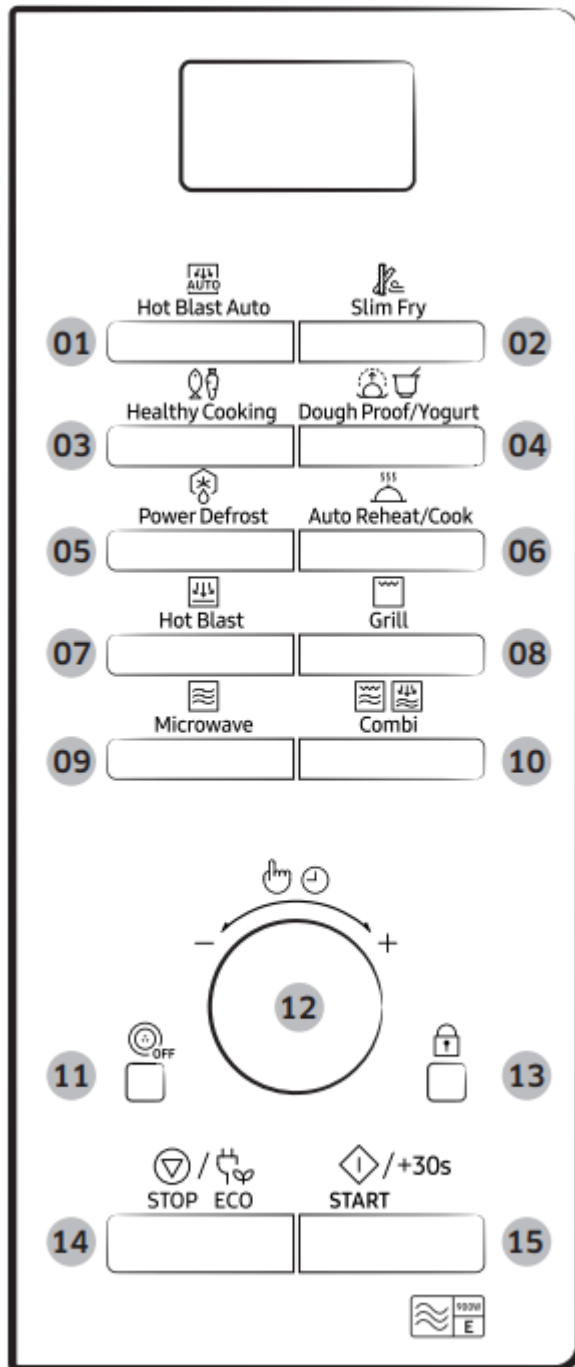

01. Hot Blast Auto
02. Slim Fry
03. Healthy Cooking
04. Dough Proof/Yogurt
05. Power Defrost
06. Auto Reheat/Cook
07. Hot Blast
08. Grill
09. Microwave
10. Combi
11. Turntable On/Off
12. Multi Function Selector Dial
13. Child Lock
14. STOP/ECO
15. START/+30s

Oven use

How a microwave oven works

Microwaves are high-frequency electromagnetic waves; the energy released enables food to be cooked or reheated without changing either the form or the colour.

You can use your microwave oven to:

- Defrost
- Reheat
- Cook

Cooking principle

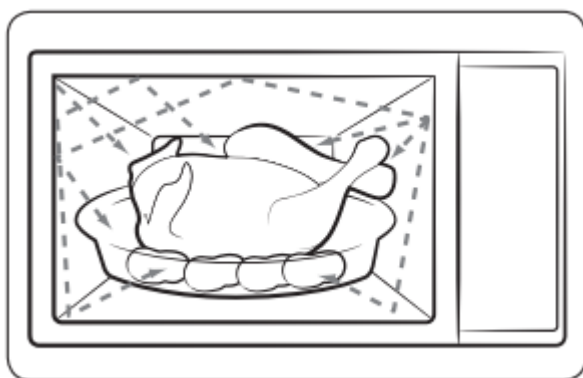

1. The microwaves generated by the magnetron reflected at cavity and are distributed uniformly as the food rotates on the turntable. The food is thus cooked evenly.
2. The microwaves are absorbed by the food up to a depth of about 1 inch (2.5 cm). Cooking then continues as the heat is dissipated within the food.
3. Cooking times vary according to the container used and the properties of the food:
 - Quantity and density
 - Water content
 - Initial temperature (refrigerated or not)

Checking that your oven is operating correctly

The following simple procedure enables you to check that your oven is working correctly at all times. If you are in doubt, refer to the section entitled “Troubleshooting” on the page 47.

NOTE

- The oven must be plugged into an appropriate wall socket. The turntable must be in position in the oven. If a power level other than the maximum (100 % - 900 W) is used, the water takes longer to boil.
- Open the oven door by pulling the handle on the upper side of the door. Place a glass of water on the turntable. Close the door.

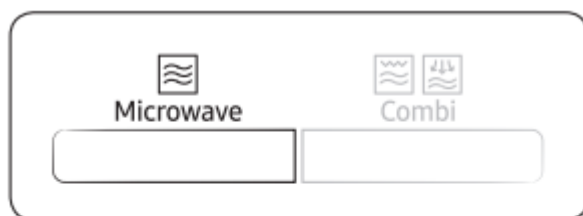

Press the Microwave mode and set the time to 4 or 5 minutes by pressing the START/+30s button. The oven heats the water for 4 or 5 Oven use minutes. The water should then be boiling.

Setting the time

When power is supplied, “88:88” and then “12:00” is automatically displayed on the display.

Please set the current time. The time can be displayed in either the 24-hour or 12- hour notation.

You must set the clock:

- When you first install your microwave oven
- After a power failure

NOTE: Do not forget to reset the clock when you switch to and from summer and winter time.

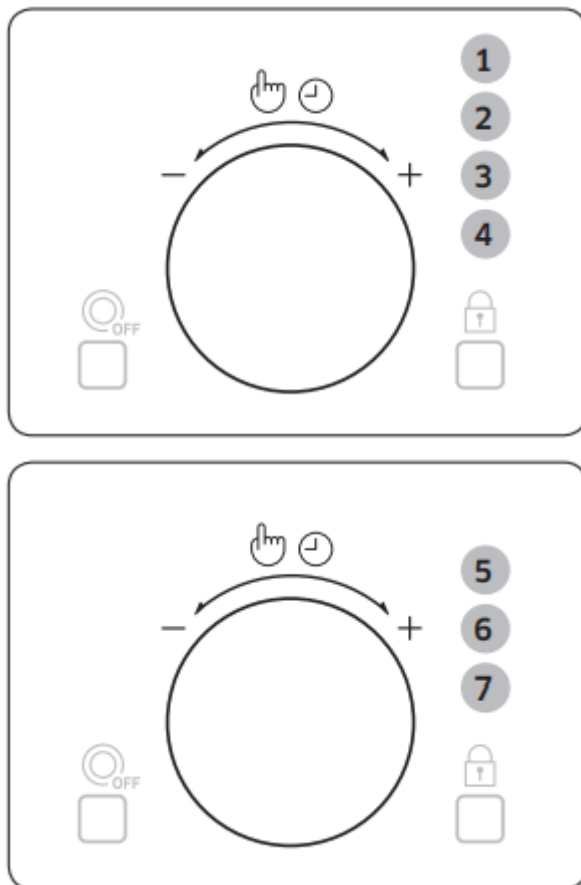

1. Press the Multi Function Selector Dial.
2. Turn the Multi Function Selector Dial to set time display type. (12H or 24H)
3. Press the Multi Function Selector Dial to complete the setup.
4. Turn the Multi Function Selector Dial to set the hour.
5. Press the Multi Function Selector Dial.
6. Turn the Multi Function Selector Dial to set the minute.

- When the right time is displayed, press the Multi Function Selector Dial to start the clock. The time is displayed whenever you are not using the microwave oven.

Cooking/Reheating

The following procedure explains how to cook or reheat food.

CAUTION: ALWAYS check your cooking settings before leaving the oven unattended. Open the door. Place the food in the centre of the turntable. Close the door. Never switch the microwave oven on when it is empty

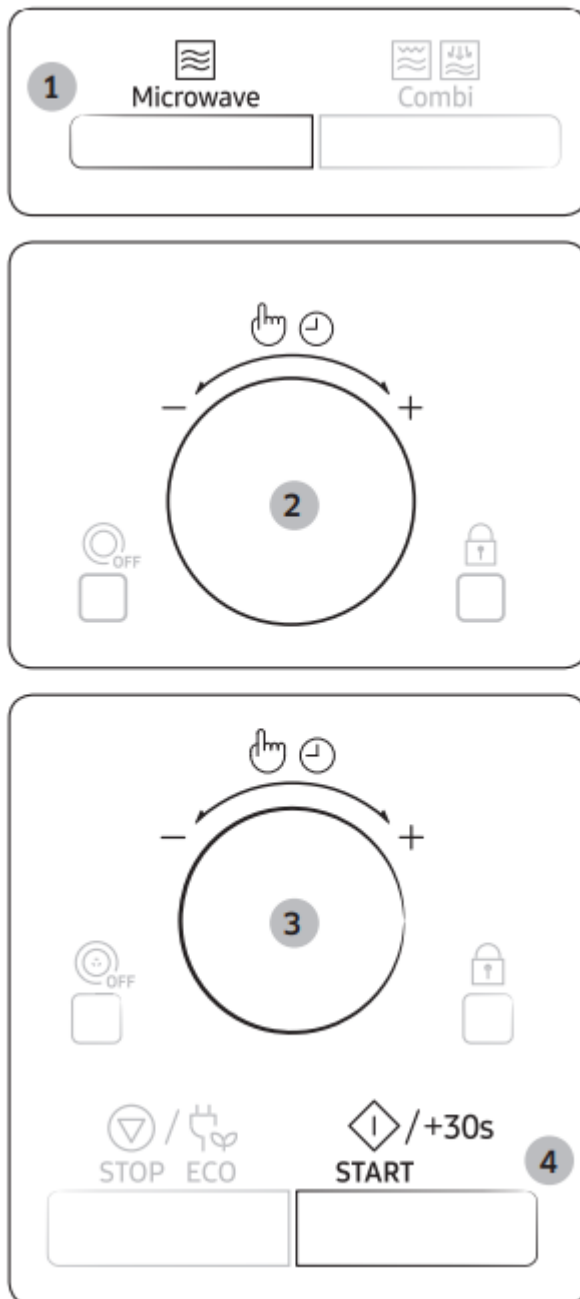

- Press the Microwave button. The following indications are displayed: (Microwave mode)
900 W (Output power)

2. Turn the Multi Function Selector Dial until the appropriate power level is displayed. At that time, press the Multi Function Selector Dial to set the power level.
 - If don't set the power level within 5 seconds, automatically changes to the cooking time setting stage.
3. Set the cooking time by turning the Multi Function Selector Dial. The cooking time is displayed.
4. Press the START/+30s button. The oven light comes on and the turntable starts rotating. Cooking starts. When it has finished.
 1. The oven beeps 4 times.
 2. The end reminder signal will beep 3 times (once every minute).
 3. The current time is displayed again.

Power levels and time variations

The power level function enables you to adapt the amount of energy dissipated and thus the time required to cook or reheat your food, according to its type and quantity. You can choose between six power levels.

Power level	Percentage	Output
HIGH	100 %	900 W
MEDIUM HIGH	67 %	600 W
MEDIUM	50 %	450 W
MEDIUM LOW	33 %	300 W
DEFROST	20 %	180 W
LOW	11 %	100 W

The cooking times given in recipes and in this booklet correspond to the specific power level indicated.

If you select a...	Then the cooking time must be...
Higher power level	Decreased
Lower power level	Increased

Adjusting the cooking time

You can increase the cooking time by pressing the START/+30s button once for each 30 seconds to be added.

- Check how cooking is progressing at any time simply by opening the door
- Increase the remaining cooking time

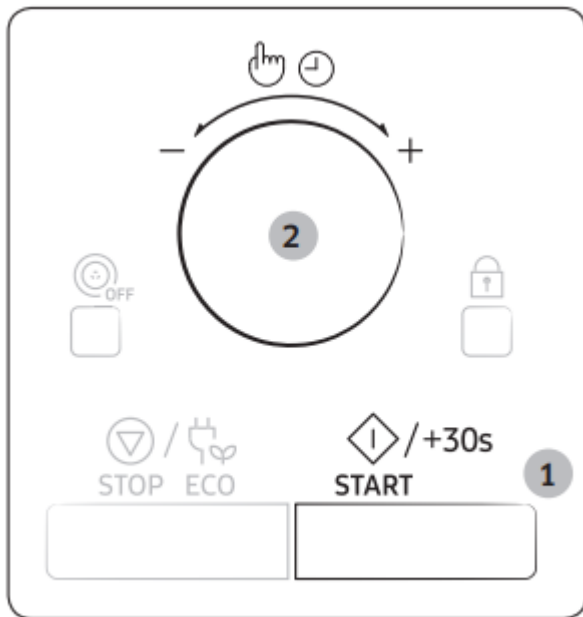

Method 1

To increase the cooking time of your food during cooking, press the START/+30s button once for each 30 seconds that you wish to add.

- Example: To add three minutes, press the START/+30s button six times.

Method 2

Just turning Multi Function Selector Dial to adjust cooking time.

- To increase cooking time, turn to right and to decrease cooking time, turn to left.

Stopping the cooking

You can stop cooking at any time so that you can:

- Check the food
- Turn the food over or stir it
- Leave it to stand

To stop the cooking...	Then...
Temporarily	<ul style="list-style-type: none"> • Open the door or press the STOP/ECO button once. Cooking stops. • To resume cooking, close the door again and press the START/+30s button.
Completely	<ul style="list-style-type: none"> • Press the STOP/ECO button once. Cooking stops. • If you wish to cancel the cooking settings, press the STOP/ECO button again.

Setting the energy save mode

The oven has an energy save mode.



- Press the STOP/ECO button. Display off.
- To remove energy save mode, open the door or press the STOP/ECO button and then display shows current time. The oven is ready for use.

Using the hot blast auto features

The 10 Hot Blast Auto features include/provide pre-programmed cooking times. You do not need to set either the cooking times or the power level. You can adjust the size of the serving by turning the Multi Function Selector Dial.

CAUTION: Use only recipients that are microwave-safe. Open the door. Place the food in the centre of the turntable. Close the door.

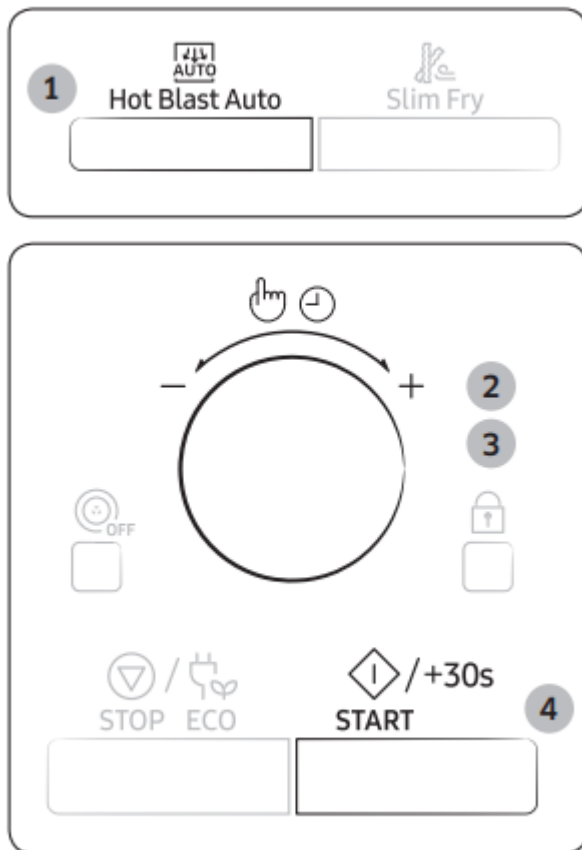

1. Press the Hot Blast Auto button.
2. Select the type of food that you are cooking by turning the Multi Function Selector Dial. Refer to the table on the following page for a description of the various preprogrammed settings. At that time, press the Multi Function Selector Dial to select the type of food.
3. Select the size of the serving by turning the Multi Function Selector Dial.
4. Press the START/+30s button. The food is cooked according to the preprogrammed setting selected. When it has finished.
 1. The oven beeps 4 times.
 2. The end reminder signal will beep 3 times (once every minute).
 3. The current time is displayed again.

Using the slim fry features

The 11 Slim Fry features include/provide pre-programmed cooking times. You do not need to set either the cooking times or the power level. You can adjust the Slim Fry category by turning the Multi Function Selector Dial.

CAUTION: Use only recipients that are microwave-safe. Open the door. Place the food in the centre of the turntable. Close the door.

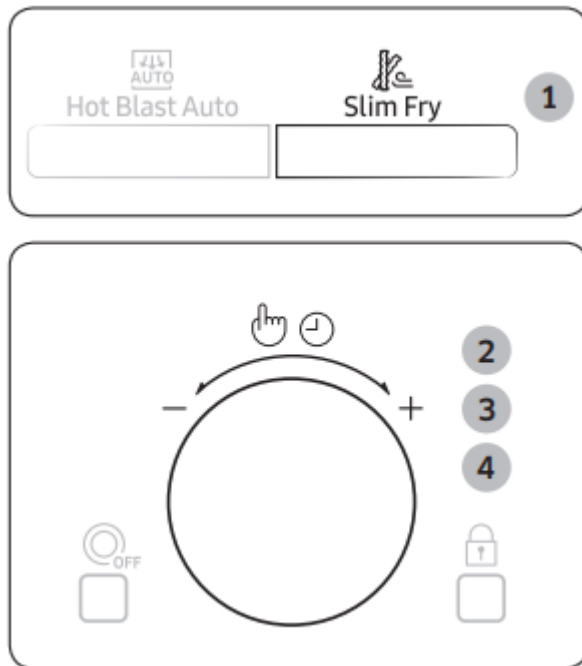

1. Press the Slim Fry button.
2. Turn the Multi Function Selector Dial to select cook category. At that time, press the Multi Function Selector Dial to select the cook category.
 1. Potatoes/Vegetables
 2. Seafood
 3. Chicken
3. Select the type of food that you are cooking by turning the Multi Function Selector Dial. Refer to the table on the following page for a description of the various pre-programmed settings. At that time, press the Multi Function Selector Dial to select the type of food.
4. Select the size of the serving by turning the Multi Function Selector Dial.



5. Press the START/+30s button. The food is cooked according to the preprogrammed setting selected. When it has finished.
 1. The oven beeps 4 times.
 2. The end reminder signal will beep 3 times (once every minute).
 3. The current time is displayed again

Using the healthy cooking features

The 13 Healthy Cooking features provide pre-programmed cooking times. You do not need to set either the cooking times or the power level. You can adjust the size of the serving by turning the Multi Function Selector Dial.

CAUTION: Use only recipients that are microwave-safe. Open the door. Place the food in the centre of the turntable. Close the door.

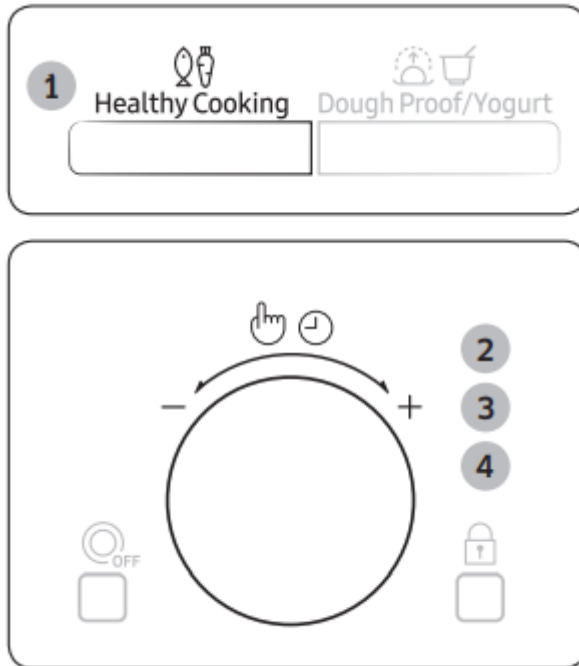

1. Press the Healthy Cooking button.
2. Select the category of food by turning the Multi Function Selector Dial and press the Multi Function Selector Dial.
 1. Grain/Pasta
 2. Vegetables
 3. Poultry/Fish
3. Select the type of food that you are cooking by turning the Multi Function Selector Dial. Refer to the table on the following page for a description of the various pre-programmed settings. At that time, press the Multi Function Selector Dial to select the type of food.
4. Select the size of the serving by turning the Multi Function Selector Dial.



5. Press the START/+30s button. The food is cooked according to the preprogrammed setting selected. When it has finished.
 1. The oven beeps 4 times.
 2. The end reminder signal will beep 3 times (once every minute).
 3. The current time is displayed again.

Using the dough proof/yogurt features

The 5 Dough Proof/Yogurt features include/provide pre-programmed cooking times. You do not need to set either the cooking times or the power level. You can adjust the Dough Proof/Yogurt category by turning the Multi Function Selector Dial after press the Dough Proof/Yogurt button.

First, place the food in the centre of the turntable and close the door.

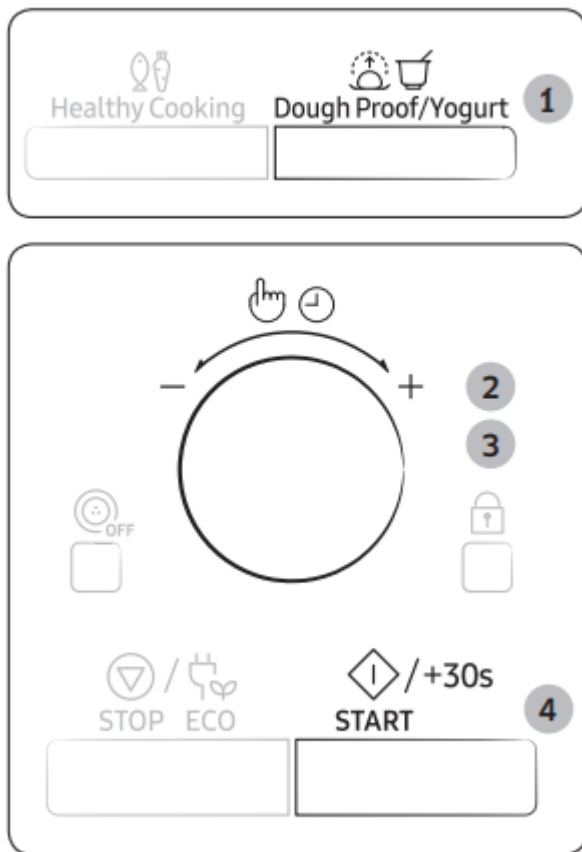

1. Press the Dough Proof/Yogurt button.
2. Select the Dough Proof or Homemade Yogurt and press the Multi Function Selector Dial.
 1. Dough Proof
 2. Homemade Yogurt
3. Select the type of food that you are cooking by turning the Multi Function Selector Dial. Refer to the table on the following page for a description of the various pre-programmed settings.

4. Press the START/+30s button. The food is cooked according to the preprogrammed setting selected. When it has finished.
 1. The oven beeps 4 times.
 2. The end reminder signal will beep 3 times (once every minute).
 3. The current time is displayed again.

Using the power defrost features

The Power Defrost features enable you to defrost meat, poultry, fish, bread, cake and fruit. The defrost time and power level are set automatically. You simply select the programme and the weight.

CAUTION: Use only recipients that are microwave-safe. Open the door. Place the food in the centre of the turntable. Close the door.

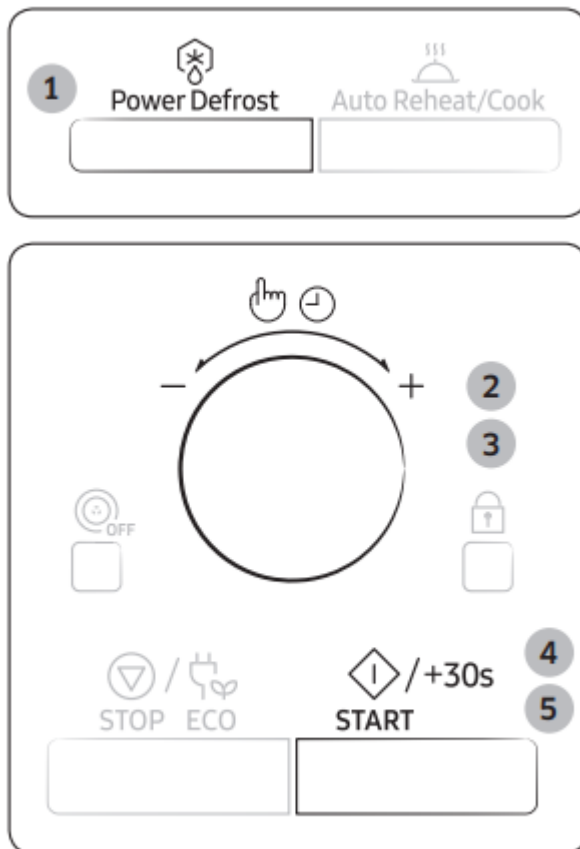

1. Press the Power Defrost button.
2. Select the type of food that you are cooking by turning the Multi Function Selector Dial. Refer to the table on the following page for a description of the various pre-programmed settings. At that time, press the Multi Function Selector Dial to select the type of food.
3. Select the size of the serving by turning the Multi Function Selector Dial.

4. Press the START/+30s button.
 - Defrosting begins.
 - The oven beeps through defrosting to remind you to turn the food over.
5. Press the START/+30s button again to finish defrosting. When it has finished.
 1. The oven beeps 4 times.
 2. The end reminder signal will beep 3 times (once every minute).
 3. The current time is displayed again.

Using the auto reheat/cook features

The 5 Auto Reheat/Cook features include/provide pre-programmed cooking times. You do not need to set either the cooking times or the power level. You can adjust the size of the serving by turning the Multi Function Selector Dial.

CAUTION: Use only recipients that are microwave-safe. Open the door. Place the food in the centre of the turntable. Close the door.

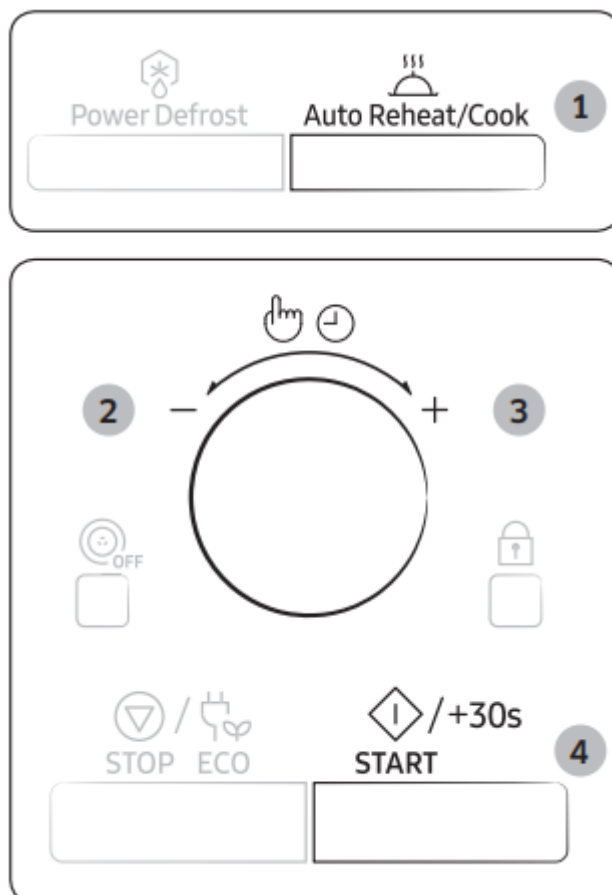

1. Press the Auto Reheat/Cook button.

2. Select the type of food that you are cooking by turning the Multi Function Selector Dial. Refer to the table on the following page for a description of the various pre-programmed settings. At that time, press the Multi Function Selector Dial to select the type of food.
3. Select the size of the serving by turning the Multi Function Selector Dial.
4. Press the START/+30s button. The food is cooked according to the preprogrammed setting selected. When it has finished.
 1. The oven beeps 4 times.
 2. The end reminder signal will beep 3 times (once every minute).
 3. The current time is displayed again.

Using the crusty plate

This crusty plate allows you to brown food not only on the top with the grill, but also the bottom of the food turns crispy and brown due to the high temperature of the crusty plate. Several items which you can prepare on the crusty plate can be found in the chart (see next page). The crusty plate can also be used for bacon, eggs, sausages, etc.

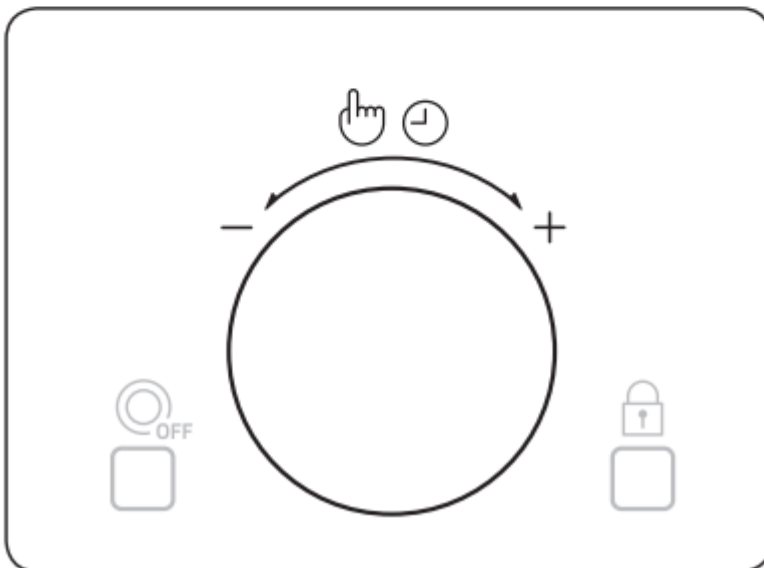
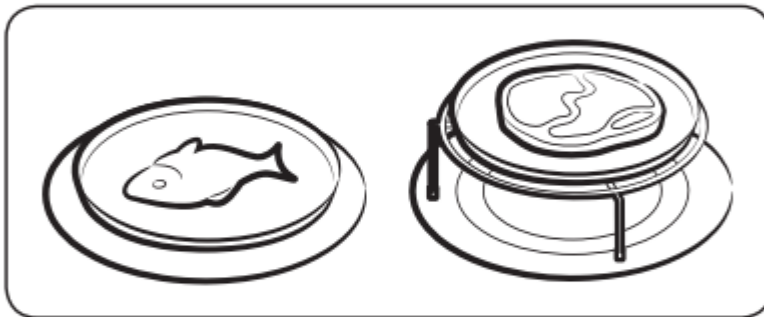
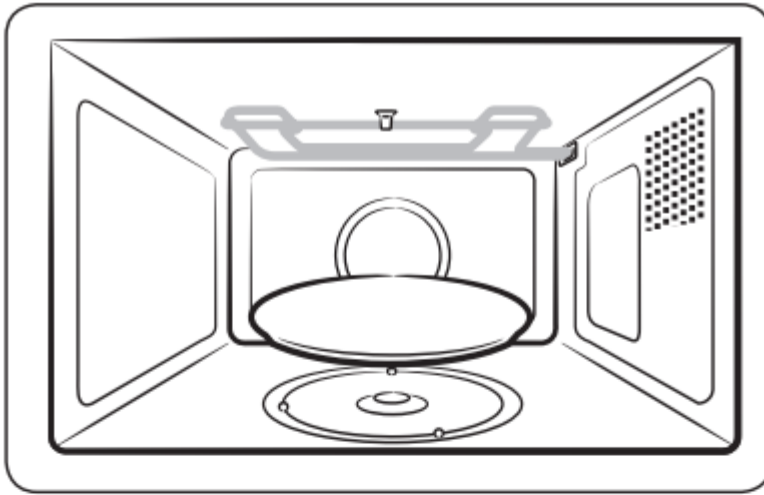

1. Place the crusty plate directly on the turntable and preheat it with highest Microwave-Grill-Combination [600 W + Grill] by following the times and instructions in the chart.
2. Brush the plate with oil if you are cooking food, such as bacon and eggs, in order to brown the food nicely.
3. Place the food on the crusty plate.
4. Place the crusty plate on the metal rack (or turntable) in the microwave.

5. Select the appropriate cooking time and power. (Refer to the table on the side)

Hot Blast

Hot Blast mode is similar to traditional oven. The microwave mode is not used. You can set the temperature, as required, in a range varying from 40 °C to 200 °C. The maximum cooking time is 60 minutes.

- Always use oven gloves when touching the recipients in the oven, as they will be very hot.
- You can get better cooking and browning, if you use the low rack.

Open the door and place the recipient on the low rack and set on turntable.

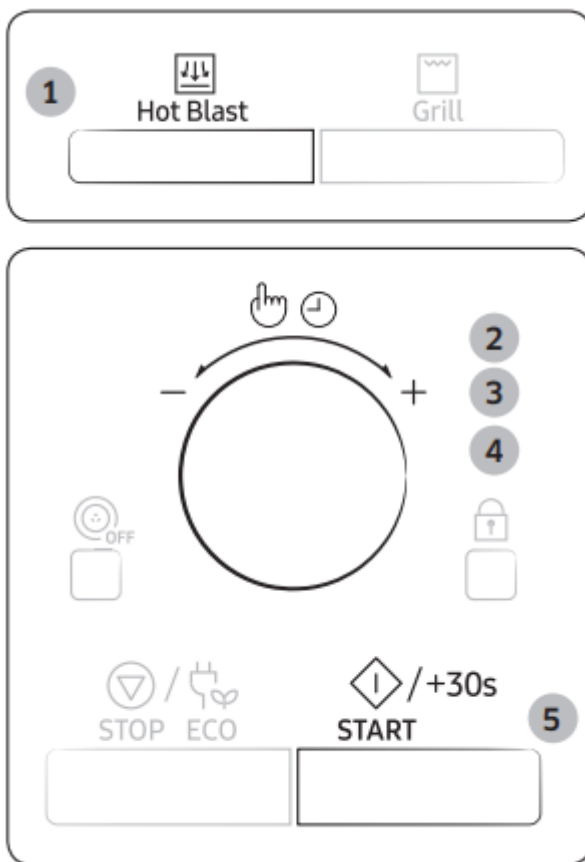

1. The Hot Blast button. The following indications are displayed:

 (Hot blast mode)
180 °C (Temperature)

2. Set the temperature by turning the Multi Function Selector Dial. (Temperature : 40-200 °C, 10 °C interval)

- If don't set the temperature within 5 seconds, automatically changes to the cooking time setting stage.

3. Press the Multi Function Selector Dial.
4. Set the cooking time by turning the Multi Function Selector Dial. (If you want to preheat the oven, select “ : 0”)
5. Press the START/+30s button. Cooking starts. When it has finished.
 1. The oven beeps 4 times.
 2. The end reminder signal will beep 3 times (once every minute).
 3. The current time is displayed again.

Grilling

The grill enables you to heat and brown food quickly, without using microwaves.

- Always use oven gloves when touching the recipients in the oven, as they will be very hot.
- You can get better cooking and grilling results, if you use the high rack.

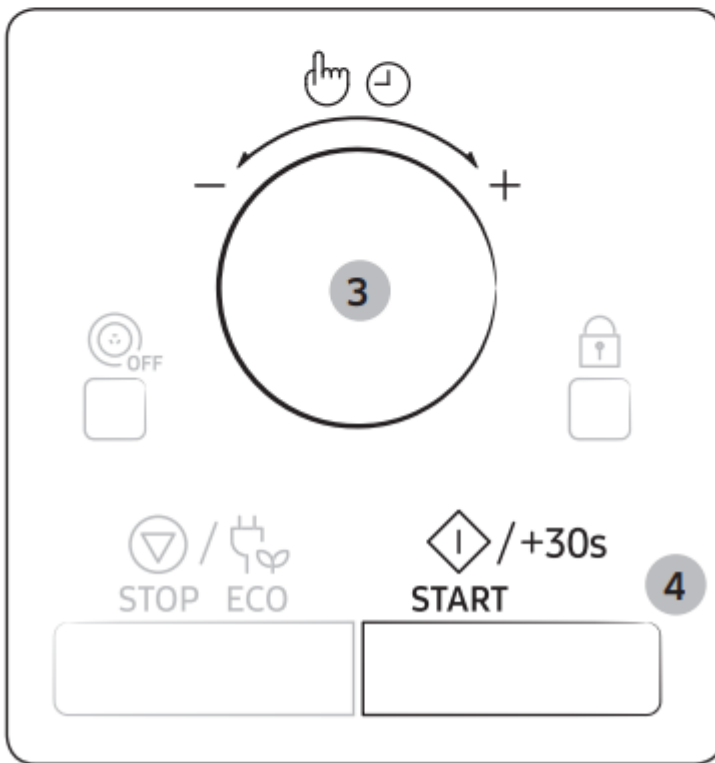
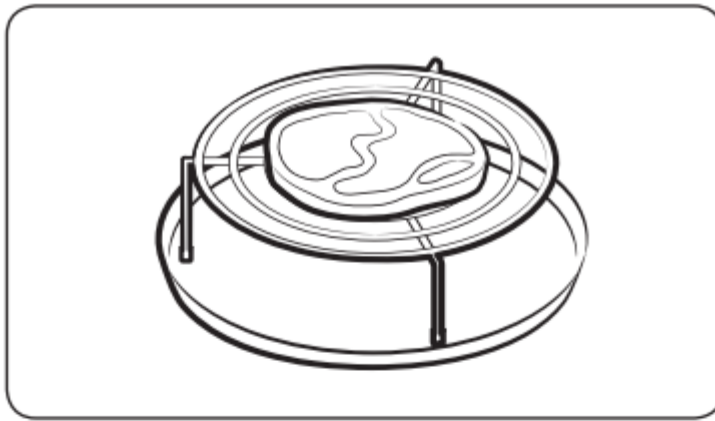

1. Open the door and place the food on the rack.
2. Press the Grill button. The following indications are displayed:

 (Grill mode)

- You cannot set the temperature of the grill.

3. Set the grilling time by turning the Multi Function Selector Dial.
 - The maximum grilling time is 60 minutes.
4. Press the START/+30s button. Grilling starts. When it has finished.
 1. The oven beeps 4 times.
 2. The end reminder signal will beep 3 times (once every minute).
 3. The current time is displayed again.

Choosing the accessories

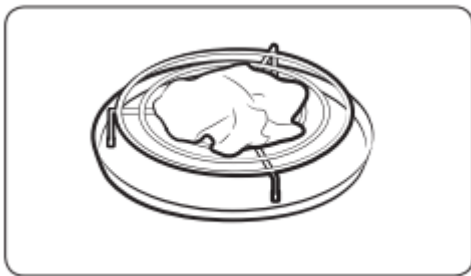

- Traditional oven cooking does require cookware. You should, however, use only cookware that you would use in your normal oven.
- Microwave-safe containers are not usually suitable for convection cooking; don't use plastic containers, dishes, paper cups, towels, etc.
- If you wish to select a combined cooking mode (microwave and grill or hot blast), use only recipients that are microwave-safe and oven-proof.

CAUTION: For further details on suitable cookware and utensils, refer to the Cookware guide on page 33.

Combining microwaves and grill

You can also combine microwave cooking with the grill, to cook quickly and brown at the same time.

CAUTION

- ALWAYS use microwave-safe and oven-proof cookware. Glass or ceramic dishes are ideal as they allow the microwaves to penetrate the food evenly.
- ALWAYS use oven gloves when touching the recipients in the oven, as they will be very hot. You can improve cooking and grilling, if you use the high rack.

Open the door. Place the food on the rack best suited to the type of food to be cooked. Place the rack on the turntable. Close the door.

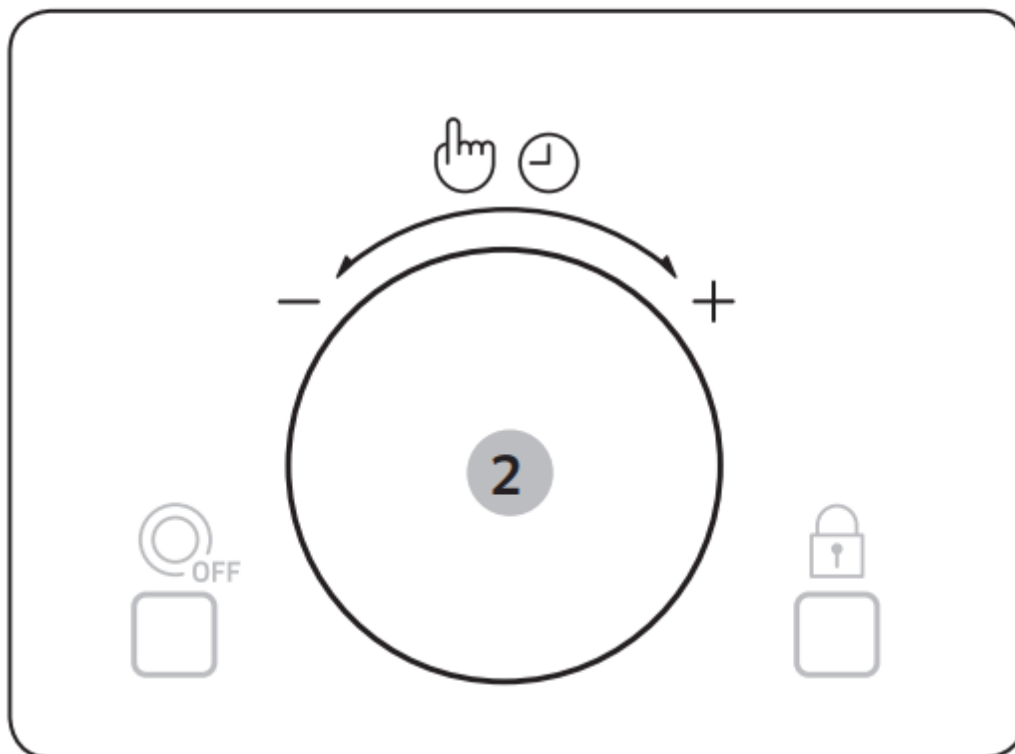

1. Press the Combi button. The following indications are displayed: Cb-1 (Microwave + Grill)

2. Make the display indicating Cb-1, and then press the Multi Function Selector Dial.

The following indications are displayed:   (Microwave & Grill combi mode) 600 W

(Output power)

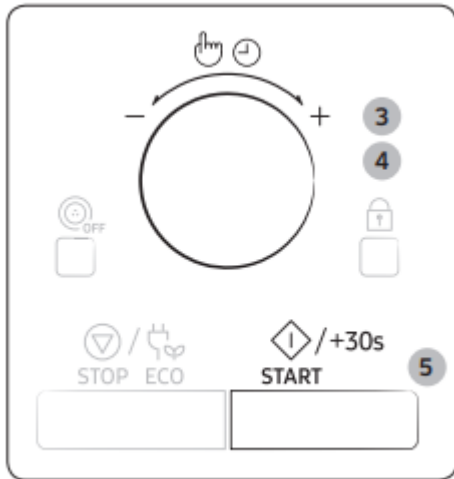

3. Select the appropriate power level by turning the Multi Function Selector Dial until the corresponding output power is displayed (600, 450, 300 W). At that time, press the Multi Function Selector Dial to set the power level.
 - You cannot set the temperature of the grill.
 - If don't set the temperature within 5 seconds, automatically changes to the cooking time setting stage.
4. Set the cooking time by turning the Multi Function Selector Dial.
 - The maximum cooking time is 60 minutes.
5. Press the START/+30s button. Combination cooking starts. When it has finished.
 1. The oven beeps 4 times.
 2. The end reminder signal will beep 3 times (once every minute).
 3. The current time is displayed again.

Combining microwaves and hot blast

Combination cooking uses both microwave energy and hot blast heating. No preheating is required as the microwave energy is immediately available. Many foods can be cooked in combination mode, particularly:

- Roast meats and poultry
- Pies and cakes
- Egg and cheese dishes

CAUTION

- ALWAYS use microwave-safe and oven-proof cookware. Glass or ceramic dishes are ideal as they allow the microwaves to penetrate the food evenly.

- ALWAYS use oven gloves when touching the recipients in the oven, as they will be very hot. You can get better cooking and browning, if you use the low rack.

Open the door. Place the food on the turntable or on the low rack which should then be placed on the turntable. Close the door. The heating element must be in the horizontal position.

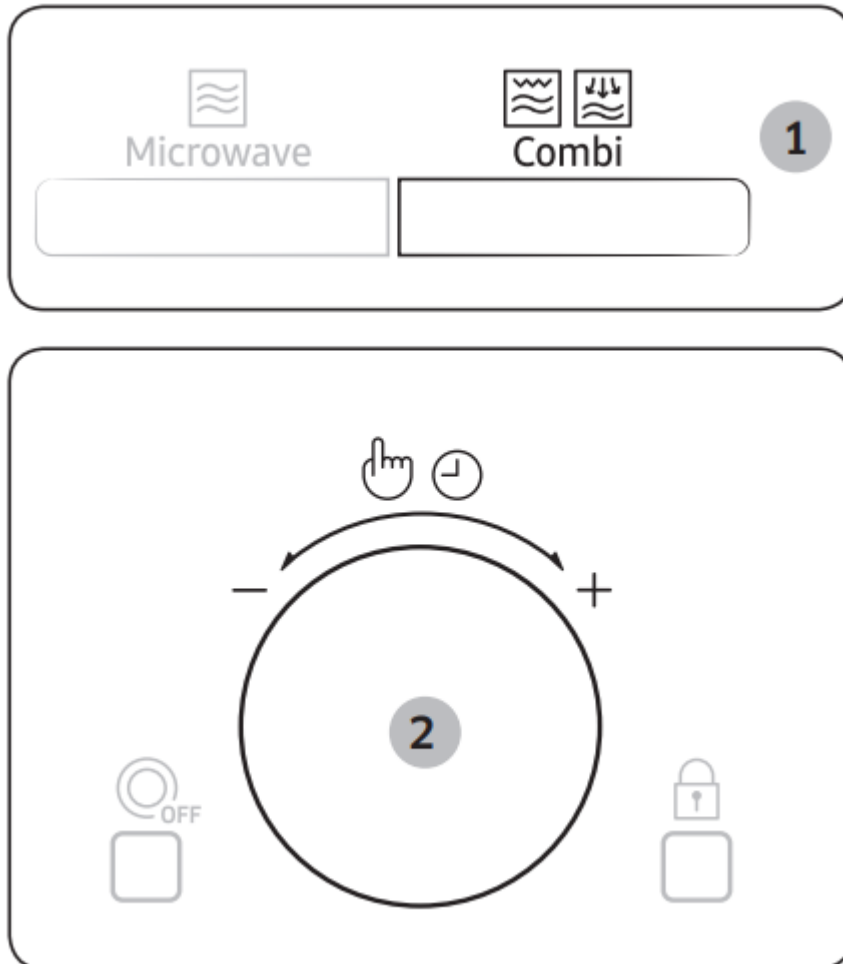

1. Press the Combi button. The following indications are displayed: Cb-1 (Microwave + Grill)
2. Make the display indicating Cb-2 (Microwave + Hot blast) by turning the Multi Function Selector Dial, and then press the Multi Function Selector Dial. The following indications

are displayed:  (Microwave & Hot blast combi mode) 600 W (Output power)

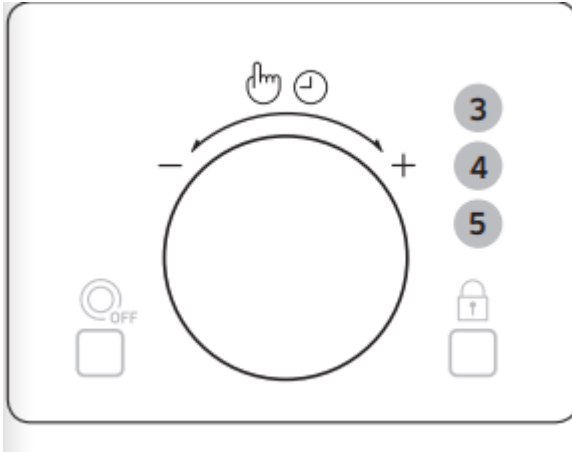

3. Select the appropriate power level by turning the Multi Function Selector Dial until the corresponding output power is displayed (600, 450, 300, 180, 100 W). At that time, press the Multi Function Selector Dial to set the power level.

- If don't set the power level within 5 seconds, automatically changes to the cooking time setting stage. (Default : 600 W)

The following indications are displayed:  (Microwave & Hot blast combi mode)
180 °C (Temperature)

4. Select the appropriate temperature by turning the Multi Function Selector Dial (Temperature : 200-40 °C). At that time, press the Multi Function Selector Dial to set the power level.

- If don't set the temperature within 5 seconds, automatically changes to the cooking time setting stage. (Default : 180 °C)

5. Set the cooking time by turning the Multi Function Selector Dial.

- The maximum cooking time is 60 minutes.



6. Press the START/+30s button. Combination cooking starts. The oven is heated to the required temperature and then microwave cooking continues until the cooking time is over. When it has finished.

1. The oven beeps 4 times.

2. The end reminder signal will beep 3 times (once every minute).
3. The current time is displayed again.

Switching the beeper off

You can switch the beeper off whenever you want.

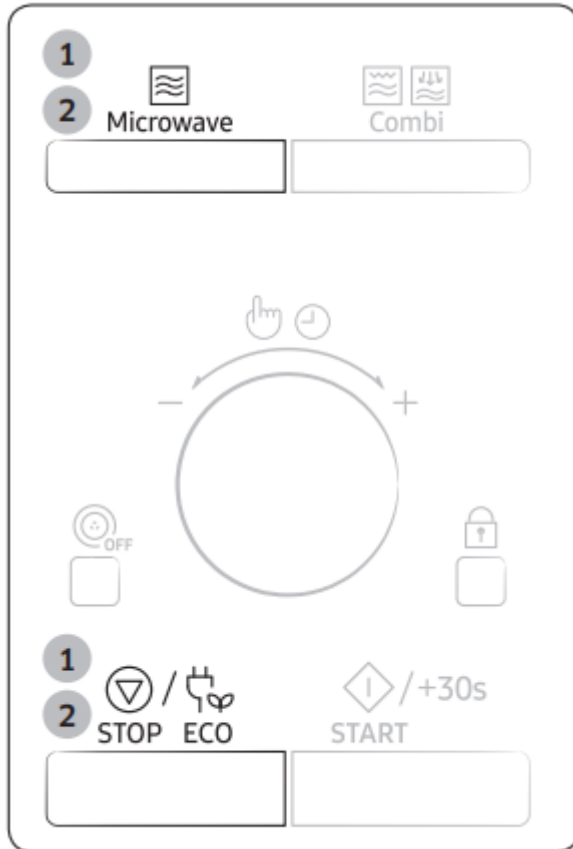

1. Press the Microwave and STOP/ECO button at the same time. The oven does not beep to indicate the end of a function.

◦

The following indications are displayed:

OFF

2. To switch the beeper back on, press the Microwave and STOP/ECO button again at the same time. The oven operates normally.

◦

The following indications are displayed:

On

Using the child lock features

Your microwave oven is fitted with a special child lock programme, which enables the oven to be “locked” so that children or anyone unfamiliar with it cannot operate it accidentally

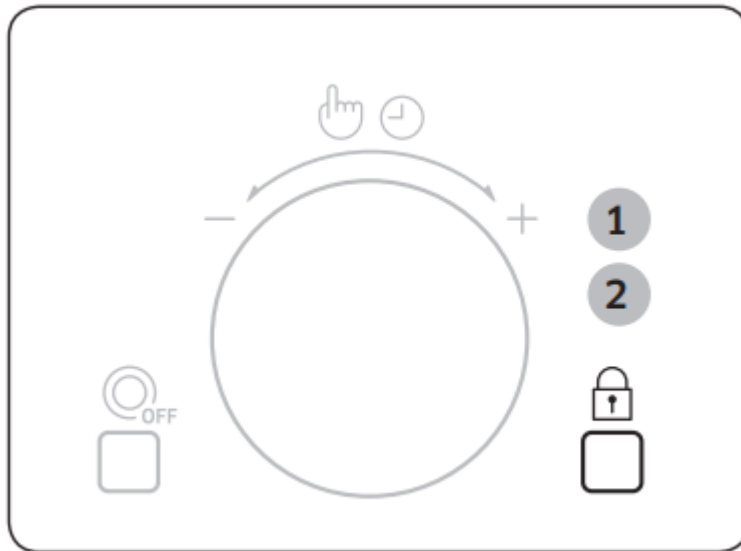

1. Press the Child Lock button for 3 second.

- The oven is locked (no functions can be selected).
-

The display shows “L”.



2. To unlock the oven, press the Child Lock button for 3 second. The oven can be used normally.

Using the turntable on/off features

The Turntable On/Off button enables you to use large dishes which fill the whole oven by stopping the turntable from rotating (only manual cooking mode).

CAUTION: The results will be less satisfactory in this case as the cooking is less even. We recommend that you turn the dish by hand halfway through the cooking process.

WARNING: Never operate the turntable without food in the oven. This may cause fire or damage to the unit.

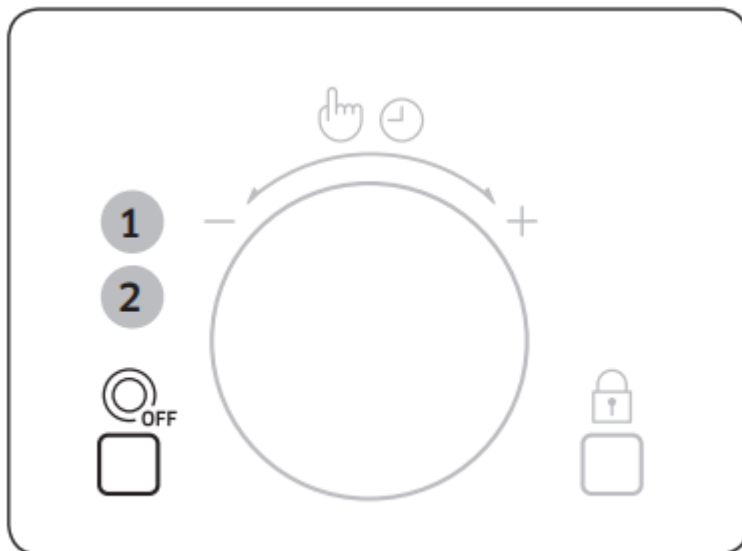

1. Press the Turntable On/Off button during setting Microwave, Grill, Hot Blast, Preheat and Combi function.

- It is not available with preprogrammed function or before press the Microwave, Grill, Hot Blast, Preheat and Combi button.

Turntable On/Off symbol appears on the display, the turntable will not rotate during the cooking.



2. To switch the turntable rotating back on, press the Turntable On/Off button again.

Turntable On/Off symbol disappears on the display, the turntable will rotate.

Troubleshooting

Troubleshooting

If you have any of the problems listed below try the solutions given.

Problem	Cause	Action
General		
The buttons cannot be pressed properly.	Foreign matter may be caught between the buttons.	Remove the foreign matter and try again.
	For touch models: Moisture is on the exterior.	Wipe the moisture from the exterior.
	Child lock is activated.	Deactivate Child lock.
The time is not displayed.	The Eco (power-saving) function is set.	Turn off the Eco function.
The oven does not work.	Power is not supplied.	Make sure power is supplied.
	The door is open.	Close the door and try again.
	The door open safety mechanisms are covered in foreign matter.	Remove the foreign matter and try again.
The oven stops while in operation.	The user has opened the door to turn food over.	After turning over the food, press the START/+30s button again to start operation.
The power turns off during operation.	The oven has been cooking for an extended period of time.	After cooking for an extended period of time, let the oven cool.
	The cooling fan is not working.	Listen for the sound of the cooling fan.
	Trying to operate the oven without food inside.	Put food in the oven.

	There is not sufficient ventilation space for the oven.	There are intake/exhaust outlets on the front and rear of the oven for ventilation. Keep the gaps specified in the product installation guide.
	Several power plugs are being used in the same socket.	Designate only one socket to be used for the oven.
There is a popping sound during operation, and the oven doesn't work.	Cooking sealed food or using a container with a lid may causes popping sounds.	Do not use sealed containers as they may burst during cooking due to expansion of the contents.
The oven exterior is too hot during operation.	There is not sufficient ventilation space for the oven.	There are intake/exhaust outlets on the front and rear of the oven for ventilation. Keep the gaps specified in the product installation guide.
	Objects are on top of the oven.	Remove all objects on the top of the oven.
The door cannot be opened properly.	Food residue is stuck between the door and oven interior.	Clean the oven and then open the door.
Heating including the Warm function does not work properly.	The oven may not work, too much food is being cooked, or improper cookware is being used.	Put one cup of water in a microwave-safe container and run the microwave for 1-2 minutes to check whether the water is heated. Reduce the amount of food and start the function again. Use a cooking container with a flat bottom.
The thaw function does not work.	Too much food is being cooked.	Reduce the amount of food and start the function again.

The interior light is dim or does not turn on.	The door has been left open for a long time.	The interior light may automatically turn off when the Eco function operates. Close and reopen the door or press the STOP/ECO button.
	The interior light is covered by foreign matter.	Clean the inside of the oven and check again.
A beeping sound occurs during cooking.	If the Auto Cook function is being used, this beeping sound means it's time to turn over the food during thawing.	After turning over the food, press the START/+30s button again to restart operation.
The oven is not level.	The oven is installed on an uneven surface.	Make sure the oven is installed on flat, stable surface.
There are sparks during cooking.	Metal containers are used during the oven/thawing functions.	Do not use metal containers.
When power is connected, the oven immediately starts to work.	The door is not properly closed.	Close the door and check again.
There is electricity coming from the oven.	The power or power socket is not properly grounded.	Make sure the power and power socket are properly grounded.
<ol style="list-style-type: none"> 1. Water drips. 2. Steam emits through a door crack. 3. Water remains in the oven. 	There may be water or steam in some cases depending on the food. This is not an oven malfunction.	Let the oven cool and then wipe with a dry dish towel.
The brightness inside the oven varies.	Brightness changes depending on power output	Power output changes during cooking are not malfunctions.

	changes according to function.	This is not an oven malfunction.
Cooking is finished, but the cooling fan is still running.	To ventilate the oven, the cooling fan continues to run for about 3 minutes after cooking is complete.	This is not an oven malfunction.
Turntable		
While turning, the turntable comes out of place or stops turning.	There is no roller ring, or the roller ring is not properly in place.	Install the roller ring and then try again.
The turn table drags while turning.	The roller ring is not properly in place, there is too much food, or the container is too large and touches the inside of the microwave.	Adjust the amount of food and do not use containers that are too large.
The turn table rattles while turning and is noisy.	Food residue is stuck to the bottom of the oven.	Remove any food residue stuck to the bottom of the oven.
Grill		
Smoke comes out during operation.	During initial operation, smoke may come from the heating elements when you first use the oven.	This is not a malfunction, and if you run the oven 2-3 times, it should stop.
	Food is on the heating elements.	Let the oven cool and then remove the food from the heating elements.
	Food is too close to the grill.	Put the food a suitable distance away while cooking.
	Food is not properly prepared and/or arranged.	Make sure food is properly prepared and arranged.

Oven		
The oven does not heat.	The door is open.	Close the door and try again.
Smoke comes out during preheating.	During initial operation, smoke may come from the heating elements when you first use the oven.	This is not a malfunction, and if you run the oven 2-3 times, it should stop.
	Food is on the heating elements.	Let the oven cool and then remove the food from the heating elements.
There is a burning or plastic smell when using the oven.	Plastic or non heatresistant cookware is used.	Use glass cookware suitable for high temperatures.
There is a bad smell coming from inside the oven.	Food residue or plastic has melted and stuck to the interior.	Use the steam function and then wipe with a dry cloth. You can put a lemon slice inside and run the oven to remove the odour more quickly.
The oven does not cook properly.	The oven door is frequently opened during cooking.	If you open the door often, the interior temperature will be lowered and this may affect the results of your cooking.
	The oven controls are not correctly set.	Correctly set the oven controls and try again.
	The grill or other accessories are not correctly inserted.	Correctly insert the accessories.
	The wrong type or size of cookware is used.	Use suitable cookware with flat bottoms.

Information code

Check code	Cause	Action
C-20	Temperature sensor is needed to check.	Press the STOP/ECO button and operate again. If it occurs again, turn off the microwave oven over 30 seconds and try setting again. If it appears again, call your local SAMSUNG Customer Care Centre.
C-21	Temperature sensor detect higher temperature than setting temperature.	Turn off the microwave oven for cooling the product and then try setting again. If it appears again, call your local SAMSUNG Customer Care Centre.
C-d0	Control buttons are pressed over 10 seconds.	Clean the keys and check if there is water on the surface around key. If it occurs again, turn off the microwave oven over 30 seconds and try setting again. If it appears again, call your local SAMSUNG Customer Care Centre.

NOTE: For any codes not listed above, or if the suggested solution does not solve the problem, contact your local SAMSUNG Customer Care Centre

Technical specifications

SAMSUNG strives to improve its products at all times. Both the design specifications and these user instructions are thus subject to change without notice.

Model		MC28M6055**
Power source		230 V - 50 Hz AC
Power consumption	Maximum power	2900 W
	Microwave	1400 W
	Grill (heating element)	1500 W
	Hot blast (heating element)	Max. 2100 W
Output power		100 W / 900 W - 6 levels (IEC-705) <ul style="list-style-type: none"> • 240 V: 900 W • 230 V: 850 W
Operating frequency		2450 MHz
Dimensions (W x H x D)	Outside (Include Handle)	517 x 310 x 463 mm
	Oven cavity	358 x 235.5 x 327 mm
Volume		28 liter
Weight	Net	17.9 kg approx.

Warning

This content is compiled from multiple sources and is provided for reference purposes only. It may not be complete or fully applicable to all situations. If you are unable to resolve your issue, please contact the product manufacturer or an authorized service provider for official support.