

Description

Some notions on humidity

- Air always contains a certain quantity of water in the form of vapour; this determines the degree of humidity in a room. The capacity of air to contain water vapour increases as its temperature increases.
- This is why in our homes, as soon as the temperature drops, the air releases the water vapour contained in it, turning into condensation, which appears on all cold surfaces such as windows, walls etc.
- The dehumidifier is an electric appliance that extracts humidity from the air, avoiding the damage that it causes. Studies have established that the ideal conditions for our health and home are achieved when relative humidity is between 40% and 60%. With very low temperatures, you are recommended to heat the room even minimally.
- This will increase the dehumidifying capacity of the appliance considerably.
- This is the only way, in fact, to allow the condensation that forms on the windows and other cold surfaces to evaporate into the air and be collected by the dehumidifier. The air released by the dehumidifier is, however, generally warmer than the air in the room.

DESCRIPTION ACCESSORIES

1. Control panel
2. Water level viewing window
3. Condensate collection tank
4. Lifting handles
5. Air intake openings
6. Air filter
7. Air outlet grille
8. Accessory box containing condensate drain nozzle and 4 castors
9. Continuous drain door

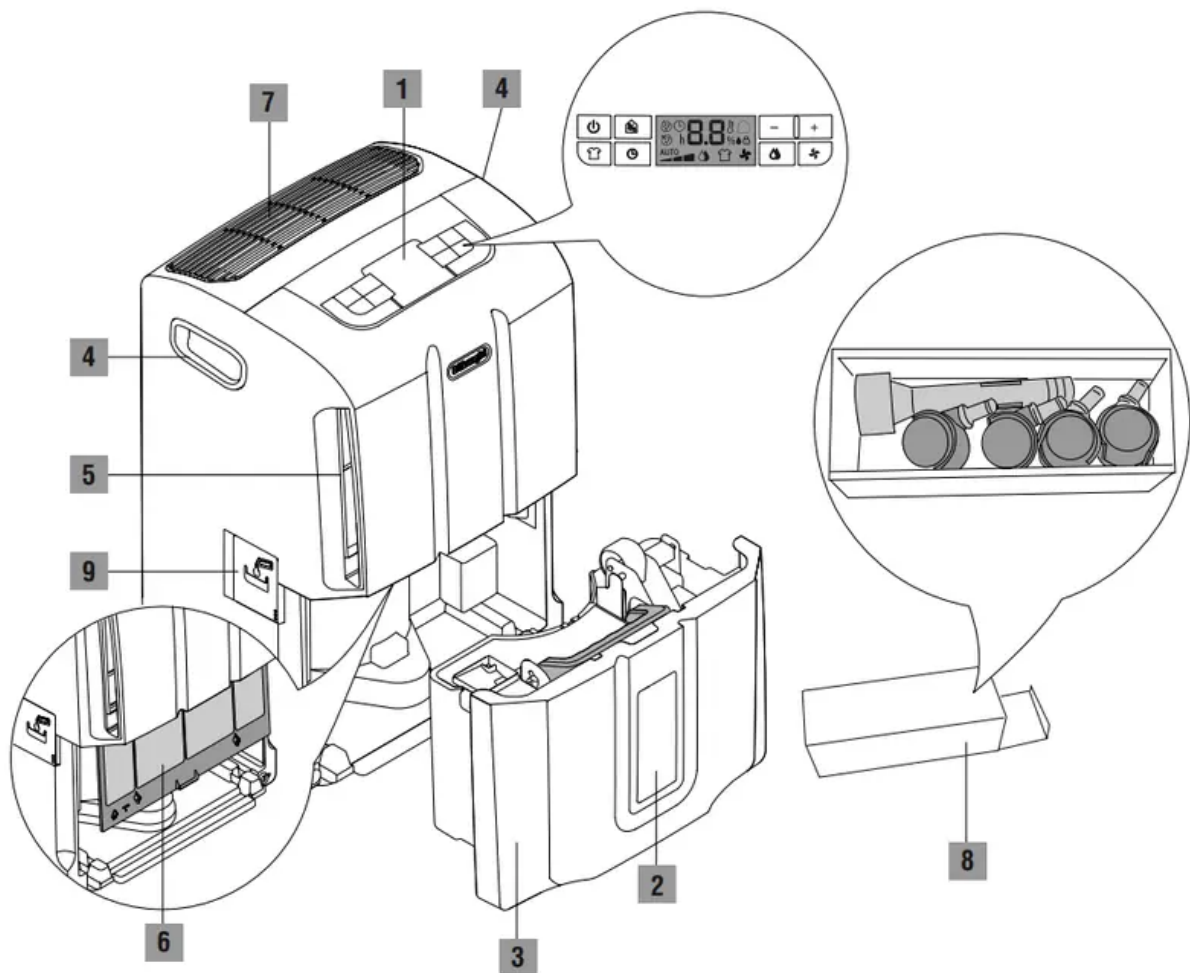

Use

Use in compliance with its intended use

- This appliance is intended for domestic use only.
- Use this appliance only as described herein.
- These instructions do not intend to cover every possible condition and situation that may arise. Common sense and caution should be applied when installing, operating and storing any appliance.

General safeguards

- Do not install the appliance in rooms where the air contains gas, oil, sulfur or near sources of heat. • Do not use the appliance on sloping surfaces.
- Keep the appliance at least 50cm away from flammable substances (alcohol, etc.) or pressurized containers (e.g. aerosol cans).
- Do not rest objects of any kind on top of the appliance.
- Always transport the appliance upright or resting on one side.

Drain the condensate tank before moving the appliance. Wait at least 1 hour after transporting the appliance before starting it

- R 134a is a refrigerant gas that complies with EC environmental regulations, never the less avoid perforating the refrigerant circuit of the appliance. At the end of its service life, the air conditioner must be disposed of at a suitable collection centre.

ENVIRONMENTAL INFORMATION: This unit contains fluorinated greenhouse gases provided for by the Kyoto Protocol. The maintenance and disposal operations must be carried out by qualified personnel only(R134a, GWP=1300).

- The materials used for packaging can be recycled. You are therefore advised to dispose of them in special differentiated waste collection containers.
- Do not use the appliance outdoors.
- Do not obstruct the air in take or outlet.

Read these instructions carefully before using the appliance.

- Keep these instructions carefully. If the appliance is transferred to other owners, they must also be provided with these instructions for use.
- Failure to comply with these instructions may result in injury and damage to the appliance. The manufacturer is not liable for damage deriving from the failure to comply with the instructions for use.
- Keep the list of Technical Service Centres and identify the Centre nearest you.

Electrical connections

After having transported the appliance wait at least one hour before starting it up.

Danger! Before plugging the appliance into the mains, check the following:

- The mains power supply corresponds to the working voltage indicated on the rating plate.
- The power socket and the electrical circuit are adequate for the required load.
- The mains socket is suitable for the plug, otherwise have the plug replaced by a qualified electrician.
- The mains socket is connected to an efficient earthing system.

Setting it up for use

- Position the appliance in the room to be dehumidified.
- It is essential to leave a free space of at least 50 cm in front of and above the dehumidifier, so as not to obstruct the air intake and outlet.
- For efficient ventilation it is advisable to leave a space of at least 5-10cm all around the appliance.

Applying the castors

If you wish to apply the castors to the appliance, proceed as follows:

1. Make sure the appliance is unplugged and the tank is empty.
2. Remove the rubber caps from the base of the appliance by pulling them out hard, using pliers if necessary (see figure 1/a).
3. Apply the castors by inserting their pins into the holes (see figure 1/b).

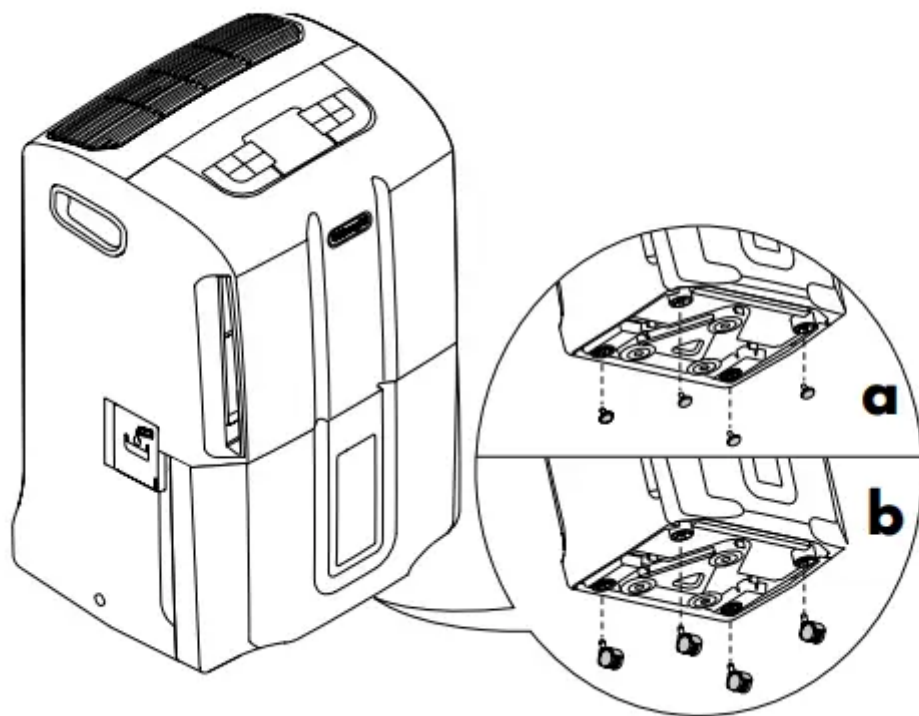

Fig. 1

Nota Bene: When carrying out these operations be careful not to incline the appliance by more than 45°; in any case, once the castors have been assembled, wait at least one hour before turning it on

Draining the condensate water

The condensate can be drained in 2 ways:

Draining into the tank

- The condensate can be drained directly into the tank. With this draining system, when the tank is full, the appliance stops and the screen displays the tank alarm



. When the tank is full, remove it as shown in fig. 2 and empty it into a sink or a bathtub.

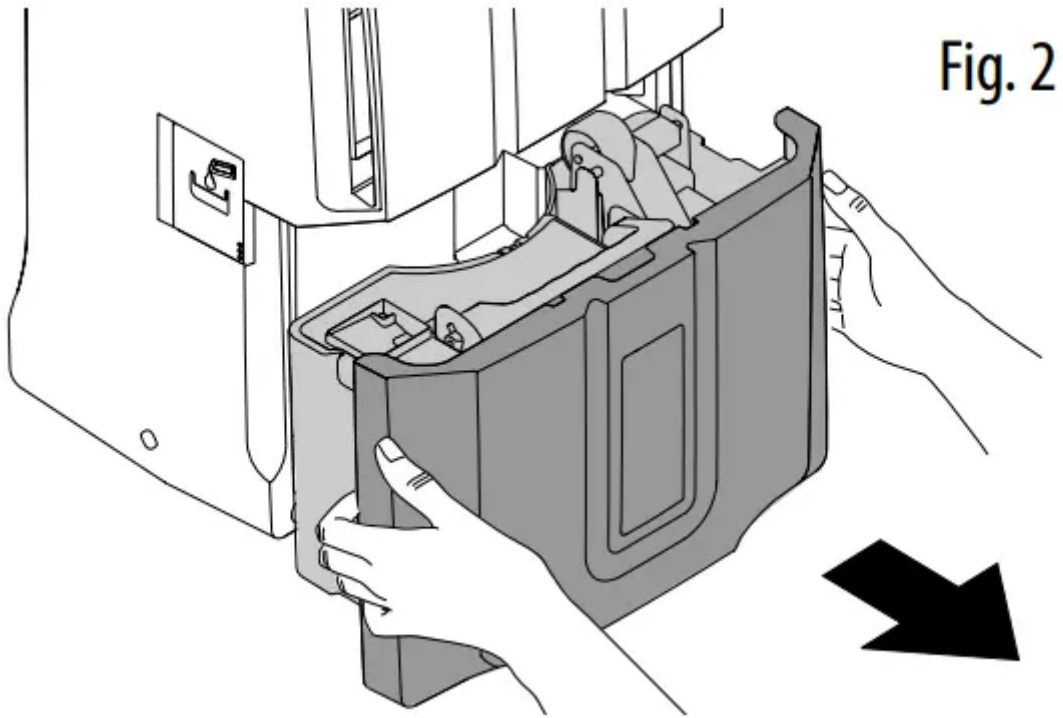

- When the operation is complete, put the tank back in correctly ,being careful to position the handle as show in figure3.

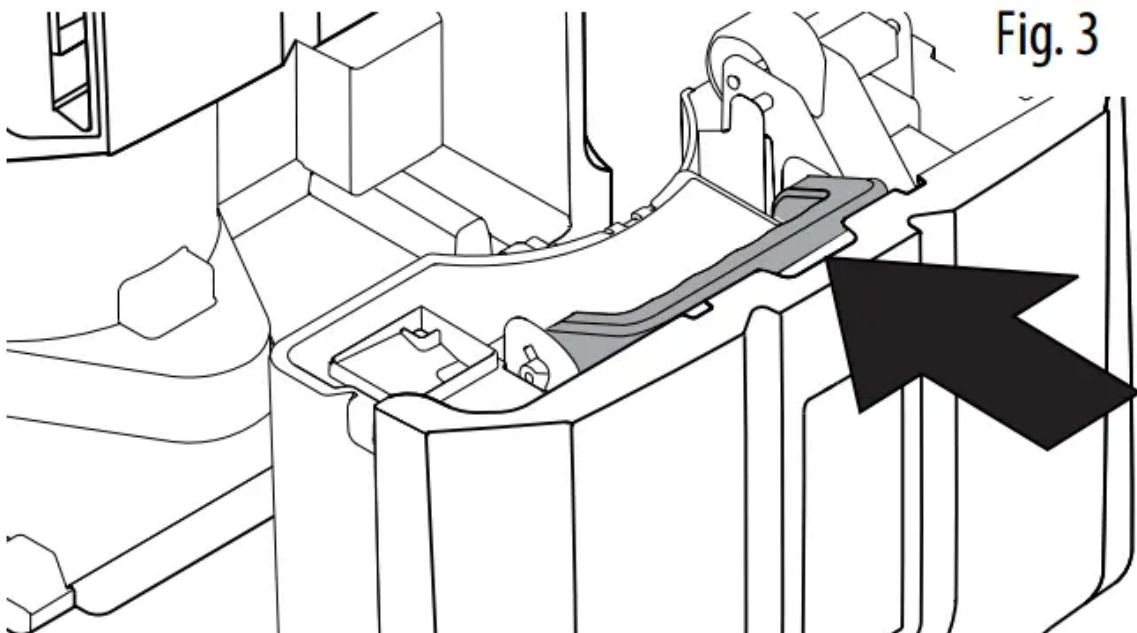

Continuous external draining

If you require the appliance to operate for a long period of time without periodically emptying the tank we advise you to set up continuous draining as follows:

- Open the door on the side of the appliance and screw the nozzle onto the fitting, as shown in figure 4.

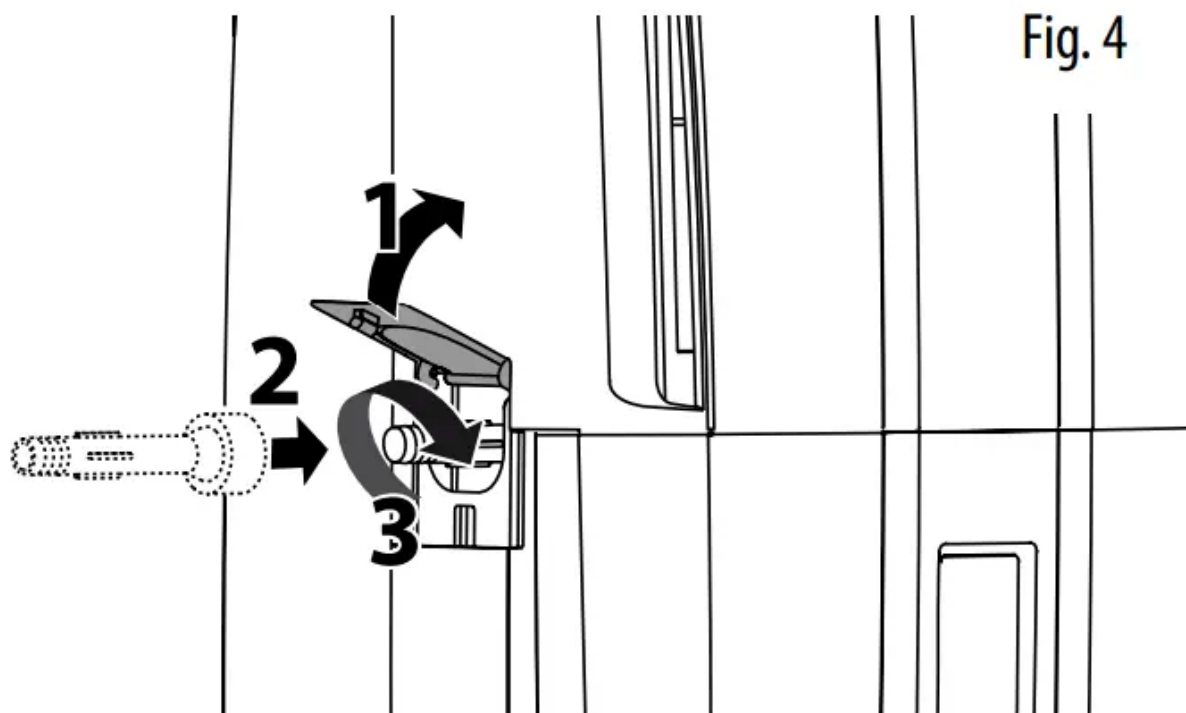

- Insert a garden hose into the nozzle and lead the end of the hose to a floor-level drain. Make sure the tank is inserted correctly.
- Make sure the hose is never placed at a height above the level of the nozzle (fig.5). Otherwise the water will continue to drain back into the tank. Make sure there are no kinks in the hose.

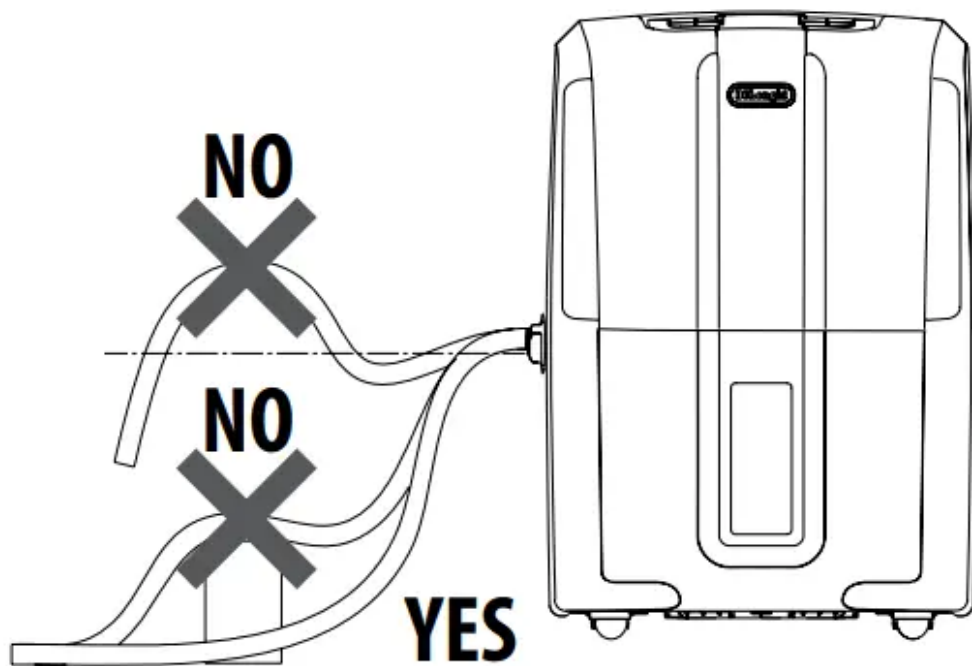
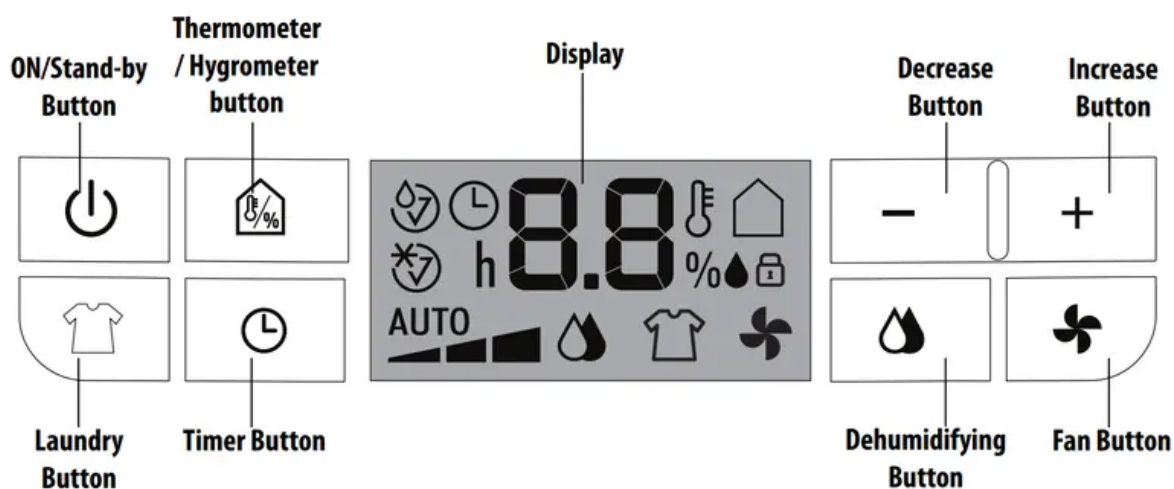









Fig. 5

Control panel



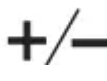

Button descriptions

- 
 "ON/Stand-by" Button: This turns the appliance on / off.
- 
 Dehumidifying Button: This starts the dehumidifying mode. Press the button repeatedly to select the desired dehumidifying level (MIN/MED/ MAX/AUTO).

-  Laundry Button: This starts the laundry mode.
-  Fan Button: This starts the fan mode. Press the  button repeatedly to select the desired level of ventilation (MIN/MED/MAX).
-  Hygrometer/Thermometer Button: This temporarily displays the temperature and the level of humidity detected in the room where the appliance is installed.
-  Timer Button: This allows you to set the timer mode to delay when the appliance comes on or goes off.
-  Increase/Decrease Buttons: These allow you to set the percentage of humidity you wish to achieve in the room, by increasing or decreasing by 5% at a time. It is also possible to set the timer using these buttons. From 0 to 10 h the time is adjusted by 30-minute increments, and from 10 to 24 h the time is adjusted by 1-hour increments.

Description of the Display

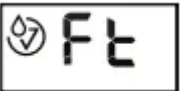
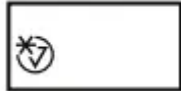
The meanings of the codes or symbols which may appear on the display:

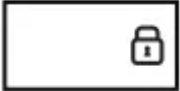
-  Stand-by: This indicates that the appliance is in Stand-by mode.
-  Tank Alarm: If this symbol appears it means that the tank is full, absent or incorrectly positioned. This alarm continues until the tank is correctly positioned.
-  Defrost alarm: At low temperatures, the appliance frequently carries out defrost cycles. During defrost this symbol will appear
-  Sensor alarms: This indicates a possible malfunction of the sensors or that the ambient humidity is too low to be detected.
-  Keyboard Lock: This symbol appears when the keyboard lock is enabled.

Nota Bene: with the aim of saving energy, after the appliance has been in stand-by for a few minutes, the display will go off.

Mode selection



MODE SELECT

- Plug the appliance into a mains socket. The appliance will operate in the previously-set

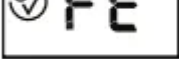
mode. If the  symbol appears on the display this means that the appliance

is in stand-by. Press the  button to turn the appliance on. If the  symbol appears, it is necessary to empty or position the tank correctly.



Dehumidifying Mode

- Press the  button. The display show  and the previously set level of relative humidity. Press the + or - button to select the desired level of humidity(30% corresponds to dry environment, 80% corresponds to a humid environment).
- Press the  button repeatedly to select the desired dehumidifying level (MIN/MED/MAX/AUTO).





- With the“AUTO” dehumidifying level the appliance independently establishes the most suitable power and level of humidity, based on the ambient conditions.
- When the room has reached the set level of humidity, it will stop. It will automatically begin dehumidifying as soon as the ambient humidity exceeds the desired level.

“Laundry” Mode

- Press the  button. The display shows . The appliance operates at its maximum dehumidifying capacity. This mode is suitable for particularly humid rooms or to allow laundry to dry quicker.

Fan Mode

- Press the  button to turn on fan mode. The display shows . This mode purifies the room using the silver ion filter that the appliance is fitted with.



- Press the  button repeatedly to select the desired ventilation speed(MIN/MED/MAX).



Hygrometer/Thermometer Function

- Press the  button. The screen temporarily displays: temperature and level of humidity in the area surrounding the appliance.
- Nota Bene: the detected and displayed measurements must be considered indicative.

Keyboard Lock Mode



- This mode is used to lock the keyboard, with the aim of avoiding unwanted tampering with the appliance. To enable or disable this mode, with the appliance on (not in stand-by), press and hold down the  and -keys for at least 3 seconds. The appliance will emit an acoustic signal. When the mode is enabled the  symbol appears on the appliance.



Change temperature scale

- To change the temperature scale from °C to °F and vice versa, with the appliance on, press the  button for at least 20 seconds. The appliance will emit an acoustic signal.





Timer Mode

How to programme delay ON



1. With the appliance in stand-by , press the  button. The  symbol will appear, together with the number of hours of delay you wish the appliance to start up.

2. With the + and - buttons set the number of hours required(0.5÷24h). Press the 
button to confirm. The  symbol will stay on.
3. When the set time has passed, the appliance will start up.

How to programme delay OFF

1. While the appliance is on, press the  button. The  symbol will appear, together with the number of hours of delay you wish the appliance to switch off.
2. With the + and - buttons set the number of hours required(0.5÷24h). Press the 
button to confirm. The  symbol will stay on.
3. When the set time has passed, the appliance will shut down.

Changing or disabling the timer mode

- If you wish to change the timer settings press the  key once, and use the + and - buttons. Press the  button to confirm. If you wish to disable the timer mode press the timer key twice. The  symbol will switch off.

Nota Bene:at start up or when the power comes back on, the appliance will start up in the last mode that was enabled before the appliance was switched off. In case of a power outage, any timer programming will be deleted.

Cleaning and maintenance /Features

Always unplug the appliance from the power socket before performing any cleaning or maintenance operations.

For safety reasons, never wash the dehumidifier using a jet of water

Cleaning the cabinet

- Clean with a slightly damp cloth and dry with a dry cloth.
- Do not use petrol, alcohol or solvents to clean the appliance.
- Do not spray liquid insecticide or similar products as they may deform the plastic.

Cleaning the anti-bacteria air filter

If the filter is dirty, air circulation is compromised and consequentially the efficiency of the dehumidifier decreases. It is therefore good practice to clean the filter at regular intervals. Frequency depends on the conditions and duration of operation. If the appliance is used constantly or frequently it is advisable to clean the filter once a week.

- Once the tank has been taken out, remove the filter by pulling it downwards (fig. 6).

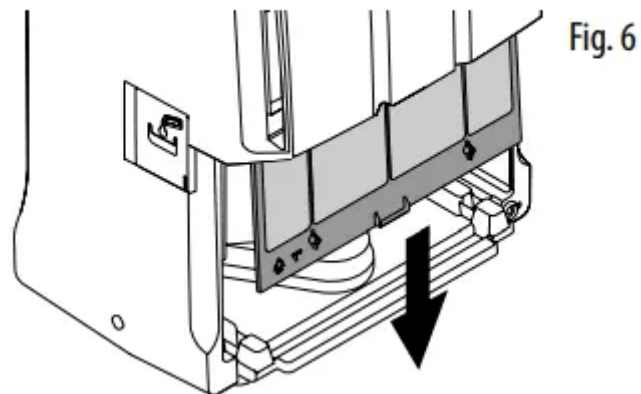

- Use a vacuum cleaner to remove dust accumulations from the filter.

If the filter is very dirty, rinse it well with warm water. The temperature of the water must not exceed 40°C. After washing the filter allow it to dry completely before putting it back in place. The anti-bacteria filter, in addition to trapping dust particles, has an anti-bacterial action. Furthermore, it considerably reduces other irritating agents such as pollen and spores.

For long periods of downtime

- After unplugging the appliance from the power socket, empty the tank.
- Clean the filter and put it back in.
- Cover the appliance with a plastic bag to protect it from dust.

TECHNICAL SPECIFICATIONS



- Power supply voltage: See rating plate
- Absorbed power: “
- Maximum absorbed power: “
- Defrost device: Yes
- Hygrometer: Yes
- Fan speed: 3
- Air filter: Yes

- Operating limits:
 - temperature 2°C-32°C
 - relative humidity 30-90%

Troubleshooting

IF SOMETHING DOES NOT WORK

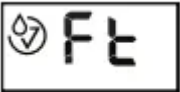
Check the following before calling the authorised Technical Service Centre operating in your area.

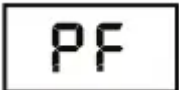
PROBLEMS	CAUSES	SOLUTION
<p>The appliance is operating in dehumidifying mode but the humidity does not decrease</p>	<p>The filter is clogged.</p>	<p>Clean the filter.</p>
	<p>Either the temperature or the humidity in the room is too low.</p>	<p>In certain conditions it is normal for the appliance not to dehumidify. Check the operating limits of the appliance in the “Technical Specifications” chapter. In certain cases it is advisable to heat the room you wish to dehumidify.</p>
	<p>The room is too large for the dehumidifying power of the appliance, or there are too many sources of humidity (boiling pots, etc.).</p>	
	<p>The set humidity value is too high.</p>	
<p>The appliance does not operate for approximately 3 minutes after startup</p>	<p>The safety device has correctly made the appliance trip</p>	<p>Wait for 3 minutes to pass</p>
 <p>appears on the display</p>	<p>The tank is missing.</p>	<p>Put the tank back in place.</p>
	<p>The tank is full.</p>	<p>Empty the tank.</p>
	<p>The tank is positioned incorrectly.</p>	<p>Position the tank correctly.</p>
 <p>appears on the display</p>	<p>The room temperature is very low.</p>	<p>Increase, if possible, the room temperature.</p>
 <p>appears on the display</p>	<p>One of the probes is faulty or the humidity in the room is too low or too high to be detected correctly.</p>	<p>See if the appliance starts working again when moved into another room with a level of humidity within the operating limits indicated in the “Technical Specifications” section. If the problem persists, call the Service Centre.</p>

Warning

This content is compiled from multiple sources and is provided for reference purposes only. It may not be complete or fully applicable to all situations. If you are unable to resolve your issue, please contact the product manufacturer or an authorized service provider for official support.

Document generated by [ManualsFile](#)