

Installation

Follow these instructions carefully to ensure a proper installation of this refrigerator and to prevent accidents before using it.

Refrigerator at a glance

The actual refrigerator and provided component parts of your refrigerator may differ from the illustrations in this manual, depending on the model and the country

01 Auto Ice Maker

02 Main panel

03 Wide Pantry

04 Freezer

05 Door bins

06 Water filter

07 Ice Maker *

08 Ice bucket *

* applicable models only

NOTE

- For energy efficiency, keep all shelves, drawers, and baskets in their original positions.
- When closing the door, make sure the vertical hinged section is in the correct position to avoid scratching the other door.
- If the vertical hinged section is reversed, put it back into the correct position, and then close the door.
- Moisture may form at times on the vertical hinged section.
- If you close a door forcefully, the other door may open.
- If the internal or external LED lamp is out of order, contact a local Samsung service center.
- If the door is left open for too long, the top internal LED will blink. This is normal.

Step-by-step installation

STEP 1 Select a site

The site must:

- Have a solid level surface without carpeting or flooring that may obstruct ventilation

- Be out of direct sunlight
- Have adequate room for opening and closing the door
- Be away from any heat source
- Provide room for maintenance and servicing
- Have a temperature range between 50 °F (10 °C) and 110 °F (43 °C)

Clearance

See the following figures and tables for space requirements for installation.

STEP 2 Flooring

If the refrigerator cannot pass through the entrance due to its size, see STEP 3 Door removal for entrance

NOTE To prevent floor damage, make sure the front leveling legs are in the upright position.

- The surface you install the refrigerator on must support a fully loaded refrigerator.
- To protect the floor, put a large piece of cardboard along the path to the refrigerator's final installation location.
- Once the refrigerator is in its final position, do not move it unless necessary to protect the floor. If you have to move the refrigerator, place thick paper or cloth such as old carpets along the path of movement.

STEP 3 Door removal for entrance

If the refrigerator cannot pass through the entrance to your home or kitchen due to its size, follow these instructions to remove and then re-install the refrigerator's doors.

WARNING

Unplug the power cord of the refrigerator before removing the doors.

Tools required (not provided)

Detach the fridge doors

Left door

1. With the doors closed, use a Phillips head screwdriver to remove the screws (x3) in the top cover.
- 2.. Disconnect the wires and the water tube from the left-side door. Do the following sequentially:
 - Decouple the connector.
 - While holding down one end of the water line coupler, disconnect the water tube

CAUTION

- Keep the water tube clips out of children's reach

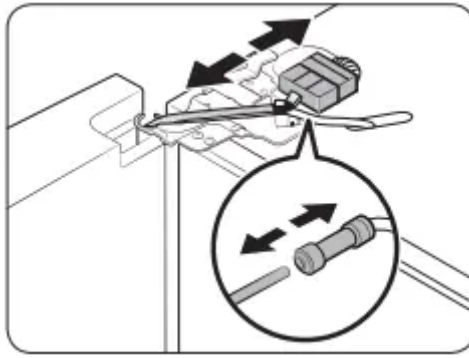

3. Gently draw up the clamp. To prevent finger injuries, do not apply a sudden force to the clamp.

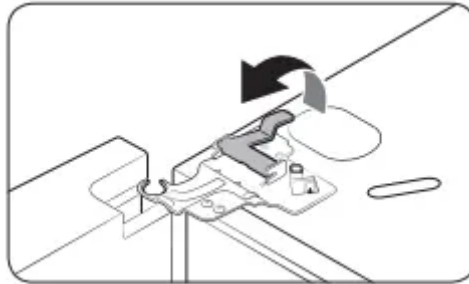

4. Pull the clamp to remove it.

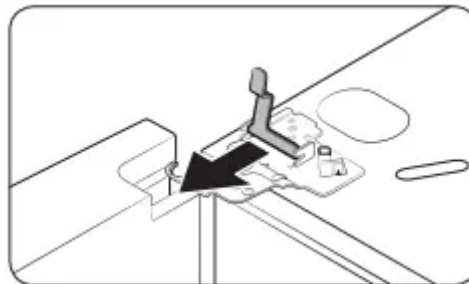

5. Open the door 90 degrees. While holding the door, pull up and remove the top hinge. Be careful not to damage the connector wires when you remove the hinge.

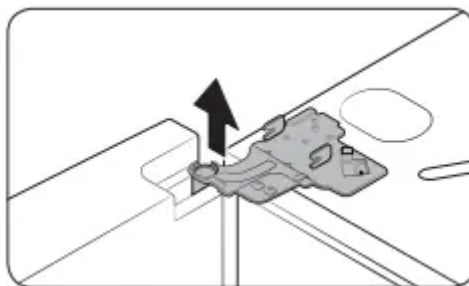

6. Gently pull up the door vertically to remove. Do not apply excessive force to the door. The door may fall, causing physical injury.

7. Lay the door down on a flat surface.

Right door

1. Disconnect the wire connectors (x2) on the right door. The position of the connectors differs with the model.

CAUTION

- Do not remove both doors simultaneously. Make sure to remove one door at a time. Otherwise, one of the doors may fall and cause physical injury.
- Make sure the refrigerator is off before disconnecting the connectors.

2. Gently draw up the clamp. To prevent finger injuries, do not apply a sudden force to the clamp.

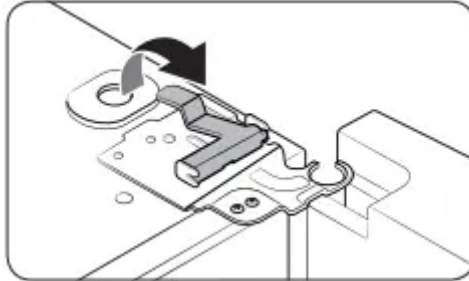

3. Pull the clamp to remove it.

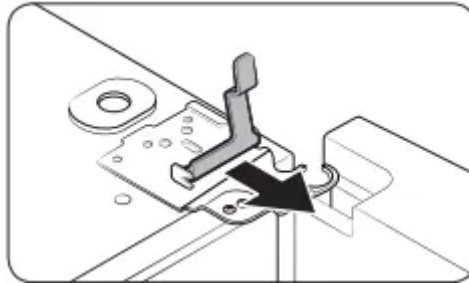

4. Open the door 90 degrees. While holding the door, pull up and remove the top hinge. Be careful not to damage the connector wires when you remove the hinge.

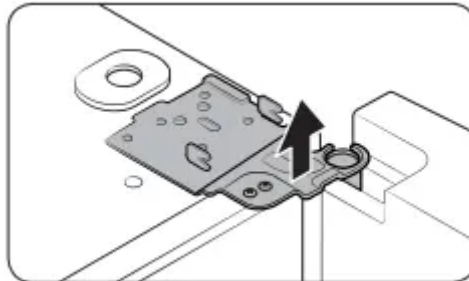

5. Gently pull up the door vertically to remove. Do not apply excessive force to the door. The door may fall, causing physical injury.

6. Lay the door down on a flat surface.

To reattach the fridge door

After you have moved the refrigerator to its final location, reattach the doors by following the removal instructions in reverse order.

To detach the freezer drawer

1. Slide open the freezer drawer and remove the upper basket.

2. Pull up to remove the lower basket from the rail assembly.

4. Press down the hooks to unlock the rail assembly.

5. While holding the upper area of the freezer drawer front, slide the drawer out all the way to remove the freezer drawer from the rail assembly.

CAUTION

- Use caution not to scratch or dent the rail assembly.
- Make sure you mount the freezer baskets in the correct position. Otherwise, the door does not open or close properly, which causes frost to build up.
- Do not store too much food in the freezer drawer. This prevents the freezer drawer from closing properly, resulting in frost buildup.

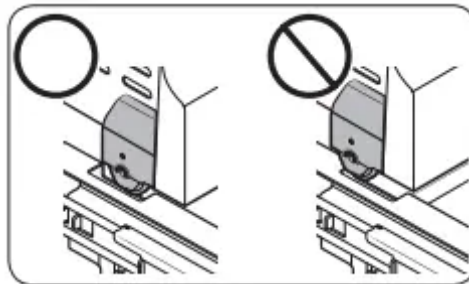

To reattach the freezer drawer

Once the refrigerator is in or near its final location, re-attach the freezer drawer by following the directions in the reverse order of removal.

STEP 4 Leveling the refrigerator

CAUTION

- When installed, the refrigerator must be leveled on a flat, solid floor. Not leveling the refrigerator can cause damage to the refrigerator or physical injury.
- Leveling must be performed with the refrigerator empty. Make sure no food items are inside the refrigerator.
- For safety reasons, adjust the front a little higher than the rear.

level the refrigerator using the special screws (levelers) on the front legs. Use a flat-head screwdriver to turn the levelers.

- To adjust the height of the left side: Insert a flat-head screwdriver into the leveler of the left side front leg. Turn the leveler clockwise to raise the left side or turn it counterclockwise to lower.
- To adjust the height of the right side: Insert a flat-head screwdriver into the leveler of the right side front leg. Turn the leveler clockwise to raise the right side or turn it counterclockwise to lower.

STEP 5 Adjust the door height and the door gap

Snap rings

The height of a door can be adjusted using the provided snap rings, which come in 4 different sizes (1 mm, 1.5 mm, 2 mm, and 2.5 mm).

To adjust the height of a door

- 1 Check the height difference between the doors, and then lift up and hold the door with the lower height
2. Insert a suitable-sized snap ring (A) between the door grommet (B) and the hinge as shown

STEP 6 Attach the handles

CAUTION The refrigerator handles must be oriented in the correct direction.

- The fridge handles must be attached so that the holes on each face each other.
- The freezer handle must be attached so that its hole faces downwards.

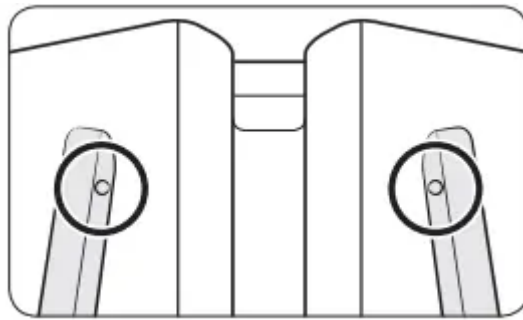

1. Using a Phillips screwdriver, attach the handle screws to the refrigerator, two for each handle respectively, as shown in the illustration to the left

2. Attach the handle to the handle screws on the door.

For type B handle: Insert the hook on the middle of the handle to its designated hole on the door, and then place the upper and lower part of the handles to the handle screws.

NOTE The design of the right side door handle may differ depending on your model.

3. Push the handle down .

4. Insert the supplied wrench into the handle hole, and then turn it clockwise to tighten.

5. Repeat Steps 2 through 4 with the second refrigerator door handle.

6. To attach the freezer handle to the refrigerator, first place the left side of the freezer handle onto the left handle screw, and then push it to the left.

7. Then, place the right side of the freezer handle onto the right handle screw

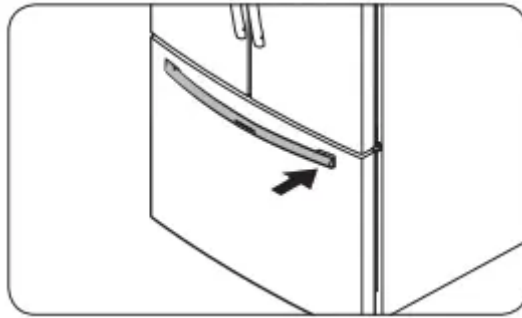

8. Insert the supplied wrench into the handle hole, and then turn it clockwise to tighten

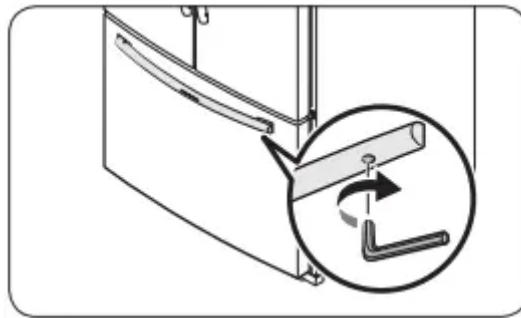

STEP 7 Connect the water dispenser line

A water dispenser with a filter is one of the helpful features on your new refrigerator. To help promote better health, the water filter removes unwanted particles from your water. However, it does not sterilize or destroy microorganisms. You may need to purchase a water purifying system to do that. The water line also connects to the ice maker. For the ice maker to operate properly, a water pressure of 20-125 psi is required. If the refrigerator is installed in an area with low water pressure (below 20 psi), you can install a booster pump to compensate for the low pressure. After you have connected the water line, make sure the water storage tank inside the refrigerator is properly filled. To do this, press the water dispenser lever until the water runs from the water outlet.

1. Shut off the main water source.
2. Insert the pipe clamp (B) and the shutoff valve (C) into the cold water line (A).

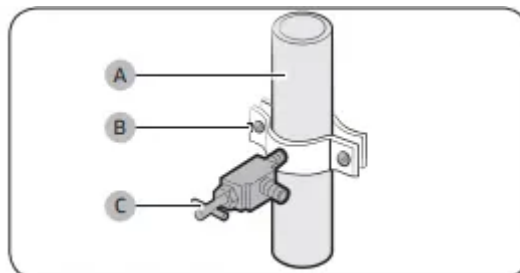

3. Connect the water line installation kit (A) to the shutoff valve (B).

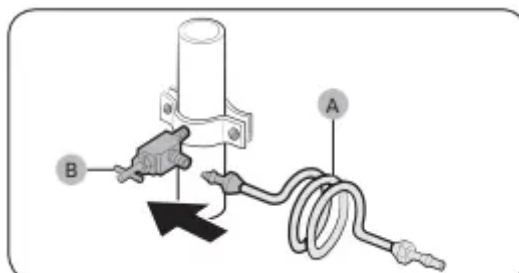

Connect the water supply line to the refrigerator

There are several items you must purchase to complete this connection. You may find these items sold as a kit at your local hardware store.

CAUTION

Do not mount the water filter on any part of the refrigerator. This may damage the refrigerator.

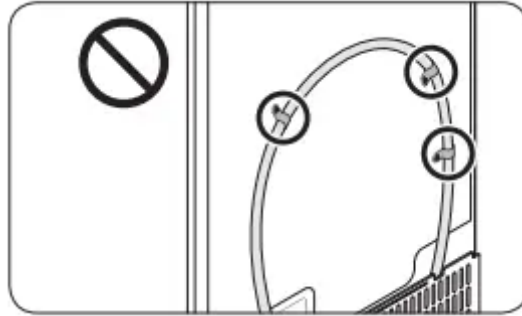

1. Connect the household water line to the assembled compression fitting.
 - If you are using copper tubing, slip the compression nut (B) (not supplied) and ferrule (not supplied) on the copper tubing (not supplied) as shown.
 - If you are using plastic tubing (A), insert the molded end (Bulb) of the plastic tubing (A) into the compression fitting.
2. Tighten the compression nut (B) onto the compression fitting. Do not over-tighten the compression nut (B).
3. Turn the water on and check for any leakage. If you find water drops or leakage in the connection areas, turn off the main water supply. Check the connections and, if necessary, tighten.
4. Flush 1 gallon of water through the filter before drinking or using the water from the refrigerator. (Flush approximately 6 minutes.) To flush, press a large glass or cup against the water dispenser lever. Fill the glass, empty it, and then repeat.
5. After you turn on the refrigerator, let the ice maker make ice for 1 to 2 days. Over that period of time, throw out the first 1 or 2 buckets of ice the ice maker makes to ensure all impurities have been removed from the water line.

NOTE

Only connect the water line to a potable water source.

- If you have to repair or disassemble the water line, cut off 1/4" of the plastic tubing to make sure you get a snug, leak-free connection.
- You can test the water line quickly using a paper cup. Under normal conditions, the water dispenser can fill a 5 3/4 oz. (170 cc) cup in about 10 seconds.

STEP 8 Initial settings

By completing the following steps, the refrigerator should be fully functioning.

1. Plug the power cord into the wall socket to turn the refrigerator on.

2. Open the door, and check if the interior light lights up.
3. Set the temperature to the coldest setting, and wait for about an hour. Then, the freezer will be slightly chilled, and the motor should be running smoothly.
4. Wait until the refrigerator reaches the set temperature. Now the refrigerator is ready for use.

STEP 9 Final check

When installation is complete, confirm that:

- The refrigerator is plugged into an electrical outlet and grounded properly.
- The refrigerator is installed on a flat, level surface with a reasonable clearance from walls and cabinets.
- The refrigerator is level and is sitting firmly on the floor.
- The door opens and closes freely, and the interior light turns on automatically when you open the door

Operations

User interface

NOTE

- For more information about other menus and apps available on the Refrigerator app. See the Online manual of your refrigerator
- The content of apps and widgets and their design is subject to change. Support for apps and widgets may be discontinued without notice, depending on the content provider's policy.
- Children's use of the refrigerator's functions, apps, and services must be supervised by adults.
- The PANDORA apps are only available in the United States.

01 Home screen

02 Soft buttons

01 Home screen

01 Apps & Widgets

- Tap a desired app or widget to launch it.
- Tap and hold an app or widget to enter Edit mode. A grid appears. In Edit mode, you can drag and drop an app or widget to a new position on the grid. When you move the app or widget to a new grid location, the location turns blue if it is available. If it is not available, it turns red.
- You can add an app or widget that has been removed from the Apps list.

02 Status bar

- Displays the status of various functions. (Refer to the following Icon descriptions table.)

Icon descriptions

02 Task bar

01 Bixby

- Tap to use Bixby.

02 Task Manager

- Tap to open the Task Manager.
- See the Task Manager section for details.

03 Home

- Tap to open the Home screen.

04 Return

- Tap to return to the previous screen.

05 Notification

- Tap to display the Quick Panel.

06 Hide/Show

- Tap to hide or show Soft buttons.
- The Hide/Show button only appears when an app is active.

Fridge Manager

To access Fridge Manager, swipe the Home screen to the left, and then tap the Fridge Manager widget.

- Tap < or > on the bottom of the widget to move between pages.
- On the first page, you can check the current temperatures or modes of each compartment as well as active special functions.
- Tap the first page to open the Fridge Manager for detailed settings.
- On the second page, you can check the filter status.
- Tap Buy Filter on the second page to open the website where you can purchase a water filter.

The Fridge Manager is a graphical representation of your refrigerator. The top half represents the refrigerator compartment, the bottom left the freezer compartment, and the bottom right the FlexZone. The temperature or mode settings for each are displayed over each section.

Fridge Manager At a Glance

01 Temperature

Set or change the temperatures for the fridge and freezer with Power mode (Power Cool or Power Freeze).

- Power Cool and Power Freeze speeds up the cooling and freezing process at maximum fan speed. The fridge and the freezer keeps running at full speed for several hours, and then returns to the previous temperature.
- To freeze large amounts of food, activate Power Freeze for at least 20 hours before putting food in the freezer

02 Special Features

Special functions available on this refrigerator are listed with a brief description.

03 Fridge Settings

See the next page for details

04 External Conditions

Displays the external (ambient) temperature and humidity.

Ice Maker

Turns the icemaker on and off. Tap and drag the button to turn on or off. Note that if the ice bucket is full of ice, the refrigerator does not start making ice when you turn on the icemaker, but displays the Ice Full indicator on the main screen. If you hold down the dispenser lever for 5 seconds, the Ice Maker Off status changes to Making ice. If you hold down the dispenser lever for 5 seconds, the Ice Maker Off status changes to Ice Maker On.

Dispenser Lock

Turns the ice and water dispensers on and off. Tap to set Dispenser Lock on or off.

Door Alarm

The door alarm sounds if you leave the door open. Tap and drag the button to turn on or off.

Temp. Unit

Switch the temperature scale between Celsius and Fahrenheit. Touch °F or °C to change the scale.

Water Filter (applicable models only)

Provides a water filter replacement tutorial and lets you reset the water filter replacement indicator. Tap to open.

NOTE

- After installing the water filter, tap Water Filter, and then tap Reset. Tapping Reset re-initializes the function that measures the time remaining until the water filter needs to be replaced again.

- If you tap Buy Filter, you will be directed to the website where you can purchase a water filter.

Self Check

Self Check is a self diagnoses function. Tap to open. Tap START to run.

Demand Response

Works with the Smart Grid energy saving manager. Tap to open. Tap and drag the button to turn on or off. See the Smart Grid section in this manual for more information.

Cooling Off

Cooling Off mode (also called Shop mode), is designed for use by retailers when they are displaying refrigerators on the shop floor. In Cooling Off mode, the refrigerator's fan motor and lights work normally, but the compressors do not run, and the refrigerator and freezer do not get cold. If Cooling Off is turned on, all cooling controls will turn to OFF on the Fridge Manager

- To activate Cooling Off, tap Activate > Proceed from Cancel/Proceed.
- To deactivate Cooling Off, tap Deactivate > Proceed from Cancel/Proceed.

Settings

Display reset (applicable models only)

If the display is not working correctly, try resetting the display. This may resolve the problem.

1. Open the right-side fridge door and locate the switch cover on the top right corner of the door.
2. Push up the cover to reveal the power switch.
3. Turn the switch off, and then turn it on again.
4. Reinsert the switch cover. You will hear a click when the cover is in place.

SmartThings

Installation

Visit the Google Play Store, Galaxy Apps, or Apple App Store and search for "SmartThings". Download and install the SmartThings app provided by Samsung Electronics to your smart device.

NOTE

- The SmartThings app is not available for some tablet and iPad and some smartphone.
 - Support that [Android] OS 6.0 or higher. (mimimum 2 GB RAM Size)
 - Support that [iOS] 10.0 or higher/iPhone 6 or higher
- For improved performance, the SmartThings app is subject to change without notice or discontinued support according to the manufacturer's policy.

- Recommended encryption systems include WPA/TKIP and WPA2/AES. Any newer or non-standard Wi-Fi authentication protocols are not supported.
- Wireless networks may be affected by the surrounding wireless communication environment.
- If your Internet service provider has registered the MAC address of your PC or modem for identification, your Samsung Smart Refrigerator may fail to connect to the Internet. If this happens, contact your Internet service provider for technical assistance.
- The firewall settings of your network system may prevent your Samsung Smart Refrigerator from accessing the Internet. Contact your Internet service provider for technical assistance. If this symptom continues, contact a local Samsung service center or retailer.
- To configure the wireless access point (AP) settings, see the user manual of the AP (router).
- Samsung Smart Refrigerators support both Wi-Fi 2.4 GHz with IEEE 802.11 b/g/n and Soft-AP protocols. (IEEE 802.11 n is recommended.)
- Unauthorized Wi-Fi wireless routers may fail to connect to applicable Samsung Smart Refrigerators.

Samsung account

You are required to register your Samsung account to use the app. If you don't have a Samsung account, follow the app's onscreen instructions to create a free Samsung account.

Getting started

Turn on the device you want to connect, open the SmartThings app on your phone, and then follow the instructions below.

If a pop-up appears saying that a new device has been found, tap ADD NOW. If a pop-up doesn't appear, tap the + button, and then select the device you want to connect from the list of available devices.

If your device isn't in the list of available devices, tap Supported Devices, select the device type (Refrigerator), and then select the specific device model. Follow the instructions in the app to set up your device. Once setup is complete, your refrigerator will appear as a "card" on your Devices screen.

Refrigerator app

Integrated control

You can monitor and control your refrigerator at home and on the go.

- Tap the refrigerator icon on the SmartThings Dashboard or tap the Devices icon at the bottom of the Dashboard, and then tap the refrigerator "card" to open the Refrigerator page.
- Check the operation status or notifications related to your refrigerator, and then change options or settings if necessary.

NOTE Some options or settings of the refrigerator may not be available for remote control.

Refrigerator settings

Recommendations for voice recognition

For the voice recognition function, there is a built-in microphone at the top of the refrigerator's display. To use the voice recognition function:

- Stand no more than 3 feet (1 meter) from the refrigerator and speak loudly and clearly towards the built-in microphone.
- Speak at a regular pace. Reduce ambient noises, such as noises from a living-room TV.

NOTE The voice recognition function may not work if you stand more than 3 feet (1 meter) away or if you speak too softly.

Samsung Family Hub

Installation

Visit the Google Play Store, Galaxy Apps, or Apple App Store and search for "Samsung Family Hub". Download and install the Samsung Family Hub app provided by Samsung Electronics to your smart device.

NOTE

- The Samsung Family Hub app is designed for Android 4.4 (KitKat) or later, or iOS 8.0 or later, and is optimized for Samsung smartphones (Galaxy S and Galaxy Note series).
- For improved performance, the Samsung Family Hub app is subject to change without notice. Support may be discontinued according to the manufacturer's policy.
- Wireless networks may be affected by the surrounding wireless communication environment.
- If your Internet service provider has registered the MAC address of your PC or modem for identification, your Samsung Smart Refrigerator may fail to connect to the Internet. If this happens, contact your Internet service provider for technical assistance.
- The firewall settings of your network system may prevent your Samsung Smart Refrigerator from accessing the Internet. Contact your Internet service provider for

technical assistance. If this symptom continues, contact a local Samsung service center or retailer.

Samsung account

You are required to register your Samsung account to use the Samsung Family Hub app. If you don't have a Samsung account, follow the app's onscreen instructions to create a free Samsung account.

NOTE To connect your smartphone and the refrigerator, register your Samsung account in Settings -> Profile.

Calendar You can share your schedule with your family.

To Do You can create and edit a to-do list.

Memo You can create and edit memos for specific users.

Whiteboard You can send White Board contents created on the refrigerator to your smartphone or vice versa.

Photo You can send photos from your smartphone to the refrigerator.

View Inside You can check the inner view of the refrigerator, use different labels to register item-specific storage periods, and keep track of them to ensure you use items by their use-by dates.

Shopping List You can create and edit shopping lists.

SMART GRID Function (Demand Response)

When the refrigerator operates in SMART GRID (Demand Response) mode, the Energy Management Refrigerator function can control energy usage or delay the operation of some functions to save money when energy prices or demand are the highest.

NOTE

- You can deactivate the SMART GRID (Demand Response) function at any time using the Peak Demand Off function.
- To use the SMART GRID (Demand Response) function, you need a separate contract with your electric utility company.

In addition, to use the Smart Grid (Demand Response) function, you must register for the service with your electric company. The company must have an EMS (Energy Management System) that supports SEP (Smart Energy profile).

Using the SMART GRID (Demand Response) Function

This feature monitors energy prices and demand information from your utility company and sends notifications to the refrigerator to run high energy consuming tasks during off peak times when electricity costs and demand are lower.

If the refrigerator receives a control signal from the utility company, the refrigerator will display the DAL (L3) ~ TALR (L4) levels on the refrigerator display and control the power consumption according to the level.

[Exception condition] The DAL and TALR control signals from a utility company work as long as product performance is maintained.

If the refrigerator receives the SMART GRID (Demand Response) signal (DAL or TALR), the refrigerator will operate in Delay Appliance Load (Display:L3) or Temporary Appliance Load Reduction (Display:L4) mode.

- Delay Appliance Load (L3): The refrigerator responds to a DAL signal by providing a moderate load reduction for the duration of the delay period. This function controls functions that consume a lot of energy such as adjusting the Cooling system, running the defrost cycle, and making ice.
 - When the refrigerator operates in DAL (L3) mode, “L3” is displayed on the refrigerator display.
 - DAL mode is automatically deactivated after it lasts for the amount of time stipulated by the DAL signal (max. 4.5 hours) or when the Peak Demand Off key is pressed.
- Temporary Appliance Load Reduction (L4): The refrigerator responds to a TALR signal by aggressively reducing the load for a short time period. This function reduces energy consumption by stopping the compressor and controlling the functions that consume a lot of energy such as the defrost cycle and making ice.
 - When the refrigerator operates in TALR (L4) mode, “L4” is displayed on the refrigerator display.
 - TALR (L4) mode is automatically deactivated after it lasts for the received duration max. 15 minutes), or when the Peak Demand Off key is pressed. The mode is immediately deactivated and the refrigerator returns to the normal state when the door is opened or closed, or the dispenser is used.

Peak Demand Off (Override mode)

When you want the refrigerator to ignore the SMART GRID (Demand Response) signal from the utility company, you can activate Peak Demand Off (Override mode).

When you activate Peak Demand Off (Override mode), the refrigerator ignores the SMART GRID (Demand Response) signal and is not controlled by the utility company.

Activating and deactivating Peak Demand Off (Override mode)

Display Type A

1. To activate/deactivate Peak Demand Off (Override mode), Press the

2. When the Peak Demand Off function is deactivated, if you press < button for 3 seconds the Peak Demand Off function will be activated.

- The corresponding indicator () turns on.

If the refrigerator receives a SMART GRID (Demand Response) signal from the utility company, 'Or' is displayed in the fridge indicator.

3. When the Peak Demand Off function is activated, if you press < button for 3 seconds the Peak Demand Off function will be deactivated.

- The corresponding indicator () turns off.

Display Type B, Type C

1. To activate Peak Demand Off (Override mode), tap until the Peak Demand indicator blinks.

2. Tap > to select the Peak Demand Off.

- The corresponding indicator (Peak Demand Off) turns on.
- If the refrigerator receives a SMART GRID (Demand Response) signal from the utility company, 'Or' is displayed in the fridge indicator.

3. To deactivate Peak Demand Off (Override mode), tap until the Peak Demand indicator blinks.

4. Tap < to select the Peak Demand On.

- The corresponding indicator (Peak Demand On) turns on.

Using the Energy Management Function

The Energy Management function enables you to control and monitor your Energy Management refrigerator using the SmartThings app for your convenience.

NOTE

- To use the Energy Management refrigerator functions, you have to install the corresponding app first.

1. Operational Status

- You can check the DR and Peak Demand Off (Override mode) status.

2. Energy Consumption Reporting

- Shows the accumulated power consumption. Power consumption data is updated every 10 minutes.

NOTE

The energy consumption report may differ from the power consumption specifications of the product depending on the operating environment and the stored food.

3. Delay Defrost Capability

- The Delay Defrost Capability function saves energy by delaying the defrost operation to a time specified by the user. You can configure the time. and this function will save energy during the specified period in a 24 hour cycle. If the time is not set, the function works with the default time settings. The default time settings are below:
- 6 am to 10 am: 1st. November ~ 30th. April
- 3 pm to 7 pm: 1st. May ~ 31th. October

To change the time setting for the Delay Defrost Capability

You can change the time setting for the Delay Defrost Capability on the app.

Provision for Open Access to the Connected Product Requirements

1. SGIP Open Standards

- Energy Consumption Reporting
- Demand Response

2. Samsung OPEN API

- Operational Status, User Settings & Messages
- ICE Maker Status: GET /icemaker/status/vs/0
- Door Open Alarm: GET /doors/vs/0
- DR Status: GET /drlc/vs/0
- Delay Defrost Capability
- Set Schedule of the Defrost Delay: POST /defrost/reservation/vs/0?op=add
- Get Schedule of the Defrost Delay : GET /defrost/reservation/vs/0
- Delete Schedule of the Defrost Delay: POST /defrost/reservation/vs/0?op=remove
- Defrost Delay On/OFF: POST /defrost/delay/vs/0

Dispenser panel

01 Water / Lock (3 sec)

Water

To dispense chilled water, press Water. The corresponding indicator turns on.

Lock (Dispenser panel / Dispenser lever)

To prevent the use of the dispenser panel buttons and the dispenser lever, press and hold Water for more than 3 seconds.

If you press and hold the button again for more than 3 seconds, the dispenser lock will be deactivated.

When dispenser lock is on, the indicator blinks if any button on the dispenser panel is pressed or the dispenser lever is pressed.

NOTE

The Lock on the dispenser panel does not affect the controls on the main panel. To lock the main panel, use the Control Lock function on the main panel.

02 Cubed Ice

Cubed Ice

Press Cubed Ice to dispense cubed ice. The corresponding indicator turns on.

03 Crushed Ice

Crushed Ice

Press Crushed Ice to dispense crushed ice. The corresponding indicator turns on.

Special features

Water/Ice dispenser

Using the dispenser, you can dispense water with or without ice. The water dispenser offers 3 options: chilled water, cubed ice, and crushed ice. To dispense chilled water, press Water on the dispenser panel. Put a water glass under the dispenser, and then push the dispenser lever.

To dispense water with ice

1. With the Ice Maker enabled, press Cubed Ice or Crushed Ice to select the ice type.
2. Put a water glass under the dispenser, and then push the dispenser lever with the glass. Ice will be dispensed from the dispenser.
3. Press Water to select water.
4. Push the dispenser lever with the glass. Water will be dispensed from the dispenser

Ice maker

The refrigerator has a built-in ice maker that automatically dispenses ice so that you can enjoy filtered water with cubed or crushed ice.

Ice making

After you have installed your refrigerator and plugged it in, follow these instructions to ensure proper ice making and to keep the ice bucket full of ice:

1. Let the refrigerator operate for at least 24 hours to ensure optimal performance.
2. Dispense the first 4 to 6 ice cubes into a glass.
3. Wait another 8 hours and dispense another 4 to 6 ice cubes.

4. Then, wait another 16 hours and dispense the first glass-full of ice.

NOTE

- If you consume all the ice at once, you must wait 8 hours before dispensing the first 4 to 6 cubes. This ensures that the ice bucket is filled with ice properly.
- Ice cubes generated rapidly may look white, which is normal.

Diagnosis

If ice does not dispense, first check the ice maker.

1. Press Test on the side of the ice maker. You will hear a chime (ding-dong) when you press the button.
2. You will hear another chime if the ice maker is operating properly.

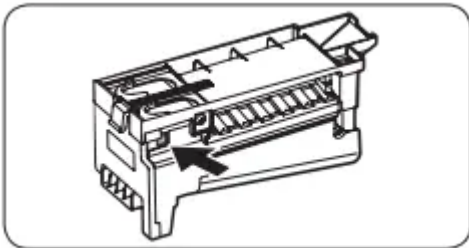

If You Turn the Ice Maker Off

If you press and hold Ice Maker for more than 3 seconds to turn the ice maker off, make sure to remove all ice cubes from the ice bucket. Remaining ice cubes may clump together, making it difficult to remove them. To remove the ice bucket, see the Ice bucket (applicable models only) section

Water clouding

Water supplied to the refrigerator flows through a core alkaline filter. During this filtering process, the water pressure of the water increases and the water becomes saturated with oxygen and nitrogen. This causes the water to look misty or cloudy temporarily when dispensed. This is normal and the water will look clear after a few seconds

Maintenance

Handling and care

Ice bucket (applicable models only)

If you do not dispense ice for an extended period, ice may form clumps inside the bucket. If this happens, remove and empty the ice bucket.

1. To remove the ice bucket, gently lift it up, and then pull it out slowly while holding the bottom of the bucket with one hand and the side with the other hand.
2. Empty the bucket.

3. When done, put the bucket back into position. If the bucket does not fit in, turn the helix screw 90 degrees, and then try again.

If the ice bucket is not firmly inserted, turn the Helix (A) 90 degrees, and then try again.

Fridge shelves

The appearance of the shelves differs by model.

- To remove a shelf, fully open the corresponding door. Hold the front of the shelf, and then gently lift up and slide out.
- To reinsert, hold the shelf at an angle so the front is higher than the back, and then insert the top hook into the top shelf notch. Then, lower the shelf and insert the bottom shelf hook into the bottom shelf notch.

CAUTION

- The tempered glass shelves are heavy. Use caution when removing them.
- The shelf must be inserted correctly. Do not insert upside down.
- Glass containers may scratch the surface of glass shelves.

Door bins

- To remove the door bin, hold the front sides of the bin, and then gently lift up to remove.
- To reinsert, insert the door bin slightly above its final location making sure that the back of the bin is against the door. Hold the rear of the door bin with both hands, and then press down so that it fits snugly

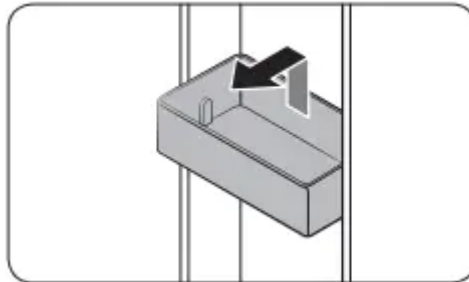

CAUTION

- Do not remove a bin that is filled with food. Empty the bin beforehand.
- Use caution when opening the door if the bottom bin contains larger bottles, which may fall over.
- Do not allow children to play with the bins. Sharp corners of the bin may cause injury.

Fridge drawers

Vegetable / fruit drawers

Gently lift up the front of the drawer and slide out.

We recommend that you remove the door bins before removing the drawer. This is to prevent damage to the door bins.

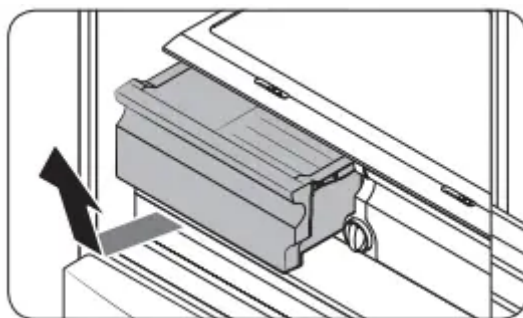

Wide Pantry

- To remove, fully open the Wide Pantry. Then, slightly lift the front side and pull straight out.
- To reinsert, push the rails to the back of the refrigerator. Then, place the Wide Pantry onto the rails and slide it back until it is in place.

Freezer baskets

Lower ice bucket (applicable models only)

1. Fully open the freezer drawer.
2. Lift the lower ice bucket to remove.

Upper basket

- To remove, fully slide open the freezer drawer. Lift up the front of the upper basket and pull to remove.
- To reinsert, align the front wheels of the upper basket with the end of the lower basket. Slide the upper basket to the front.

Lower basket

- To remove, first remove the upper basket. Then, tilt up the front of the lower basket to pull out.
- To reinsert, put the basket onto the rail assembly rear side first.

CAUTION

- Do not twist the basket when removing or reinserting the basket. The basket can be scratched.
- To prevent physical injury, property damage, or suffocation, keep children away from freezer baskets that have been removed.
- Do not remove the divider.

- Put the wheels of the upper basket on the end of the rails of the lower basket. Then, slide the upper basket all the way to the front. Otherwise, the drawer will not open or close properly, which will cause frost to build up.

Cleaning

Interior and exterior

Regularly use a dry cloth to remove all foreign substances such as dust or water from the power plug terminals and contact points.

To clean the refrigerator

1. Unplug the power cord.
2. Use a moistened, soft, lint-free cloth or paper towel to clean the refrigerator's interior and exterior.
3. When done, use a dry cloth or paper towel to dry well.
4. Plug in the power cord.

Rubber seals

If the rubber seals of a door become dirty, the door may not close properly and reducing refrigerator performance and efficiency. Use a mild detergent and damp cloth to clean the rubber seals. Then, dry well with a cloth.

Rear panel

To keep cords and exposed parts of the rear panel free of dirt, vacuum the panel once or twice a year.

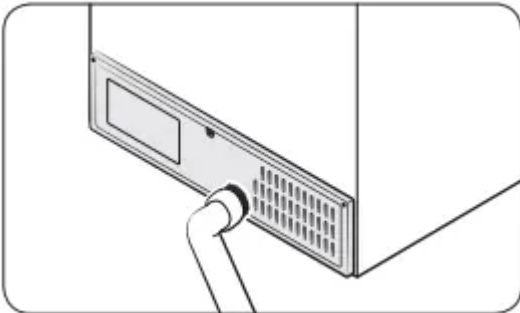

CAUTION

Do not remove the rear panel cover. Electric shock may occur.

Replacement

Water filter

The Water Filter Indicator (**Filter**) turns red to let you know it is time to replace the water filter. Before replacing the filter, make sure the water supply line is shut off.

1. Shut off the water supply line.

2. Turn the knob of the filter cartridge 180 degrees counterclockwise (1/4 turn). The filter cartridge unlocks.

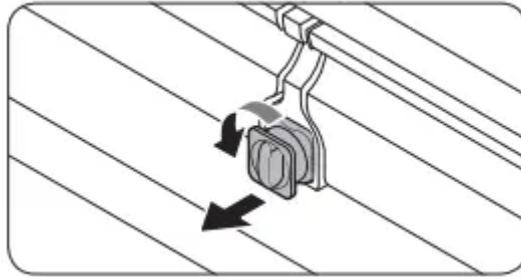

3. Pull out to remove the cartridge.

- If the water filter is severely contaminated, the cartridge may not be easy to remove. If that is the case, use force to remove the cartridge.
- To prevent water leaks from the filter opening, pull the cartridge straight out while removing it.

4. Insert a new filter cartridge. Use only Samsung-provided or approved filters.

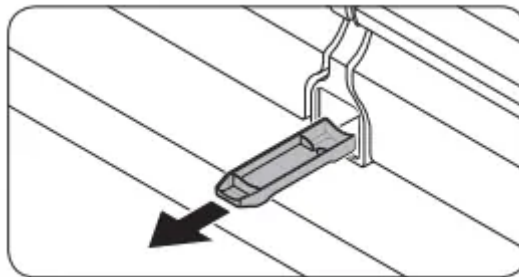

5. Turn the cartridge knob clockwise to lock into place.

6. Press and hold Ice Maker on the main panel for 3 seconds to reset the life cycle detector. The Filter Reset indicator (**Filter**) turns off.

7. When you are done replacing the filter, open the water valve and run water through the dispenser for about 7 minutes. This is to remove impurities and air from the water line.

Reverse osmosis water filtration system

The water pressure of the water supply system to a reverse osmosis water filtration system must be between 30 to 120 psi (206 to 827 kPa).

The water pressure of the reverse osmosis water filtration system to the refrigerator's cold water line must be at least 40 psi (276 kPa). If the water pressure is below these specifications:

- Check if the sediment filter in the reverse osmosis system is blocked. Replace the filter if necessary.
- Refill the water tank in the reverse osmosis system with water.

- If your refrigerator has a water filter, it may further reduce the water pressure when used in conjunction with a reverse osmosis system. Remove the water filter.

For more information or servicing, contact a licensed plumbing professional.

Ordering a new filter

To purchase a new water filter, contact a local Samsung service center or visit www.samsungparts.com on the web.

LED Lamps

To replace the lamps of the refrigerator, contact a local Samsung service center.

Troubleshooting

General

Temperature

Fridge/freezer does not operate. Fridge/freezer temperature is warm.

- Power cord is not plugged in properly.
 - Properly plug in the power cord.
- Temperature control is not set correctly.
 - Set the temperature lower.
- Refrigerator is located near a heat source or direct sunlight.
 - Keep the refrigerator away from direct sunlight or a heat source.
- Not enough clearance between refrigerator and nearby walls or cabinets.
 - Make sure there is a gap of at least 2.5 inches (5 cm) between the refrigerator back and sides and any nearby walls or cabinets.
- The refrigerator is overloaded. Food is blocking the refrigerator vents.
 - Do not overload the refrigerator. Do not allow food to block vents.

Fridge/freezer is over-cooling.

- Temperature control is not set correctly.
 - Set the temperature higher.

Interior wall is hot.

- Refrigerator has heat-proof piping in the interior wall.
 - To prevent condensation from forming, the refrigerator has heat-proof piping in the front corners. If the ambient temperature rises, this equipment may not work effectively. This is not a system failure.

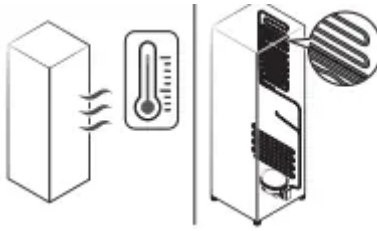

Odors

Refrigerator has odors.

- Spoiled food.
 - Clean the refrigerator and remove any spoiled food.
- Food with strong odors.
 - Make sure strong smelling food is wrapped airtight.

Frost

Frost around the vents.

- Food is blocking the vents.
 - Make sure no food blocks the refrigerator vents.

Frost on interior walls.

- Door is not closed properly.
 - Make sure food does not block the door. Clean the door gasket.

Condensation

Condensation forms on the interior walls.

- If door is left open, moisture enters the refrigerator.
 - Remove the moisture and do not leave a door open for extended periods of time.
- Food with high moisture content.
 - Make sure food is wrapped airtight.

Water/ice (dispenser models only)

Water flow is weaker than normal.

- Water pressure is too low.
 - Make sure the water pressure is between 20 to 120 psi.

Ice maker makes a buzzing sound.

- The Ice Maker function is activated, but the water supply to the refrigerator has not been connected.
 - Press Ice Maker off.

Ice maker does not make ice.

- Ice maker has just been installed. You must wait for 12 hours for the refrigerator to make ice.
 - Freezer temperature is too high. Set the freezer temperature below 0 °F (-18 °C) or -4 °F (-20 °C) in warm ambient air.
- Dispenser panel Lock is activated.
 - Deactivate dispenser panel Lock.
- Ice maker is off.
 - Turn on the ice maker.

Ice does not dispense.

- Ice may jam if the ice dispenser is not used for a long time (approx. 3 weeks).
 - If you won't be using the refrigerator for a long time, empty the ice bucket and turn off the ice maker.
- Ice bucket is not properly inserted.
 - Make sure the ice bucket is properly inserted.
- Water line is not connected properly or water supply is not on.
 - Check if the water line is installed correctly. Check if the water line stop cock is closed.

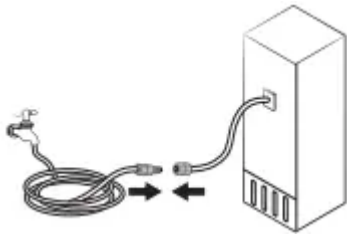

Water does not dispense.

- Water line is not connected properly or water supply is not on.
 - Check if the water line is installed correctly. Check if the water line stop cock is

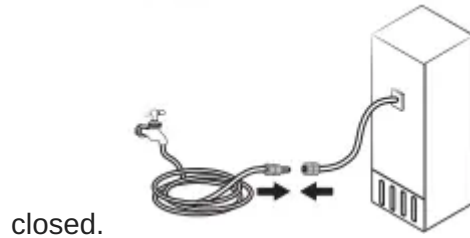

- closed.
- Dispenser panel Lock is activated.
 - Deactivate dispenser panel Lock.
- A third-party water filter was installed.
 - Use only Samsung-provided or approved filters.
 - Unapproved filters may leak and damage the refrigerator.
- Water filter indicator turns on or blinks.
 - Replace the water filter. After replacing, reset the filter indicator sensor.

Do you hear abnormal sounds from the refrigerator?

Before calling for service, review the information below. If you still have questions about sounds your refrigerator is making, please call Samsung Customer Care at 1-800-SAMSUNG (726-7864). Note that you will be charged for any service visits related to normal operating sounds in which no defects were found.

These sounds are normal.

- When starting or ending an operation, the refrigerator may make sounds similar to a car engine ignition. As the operation stabilizes, the sounds will decrease.

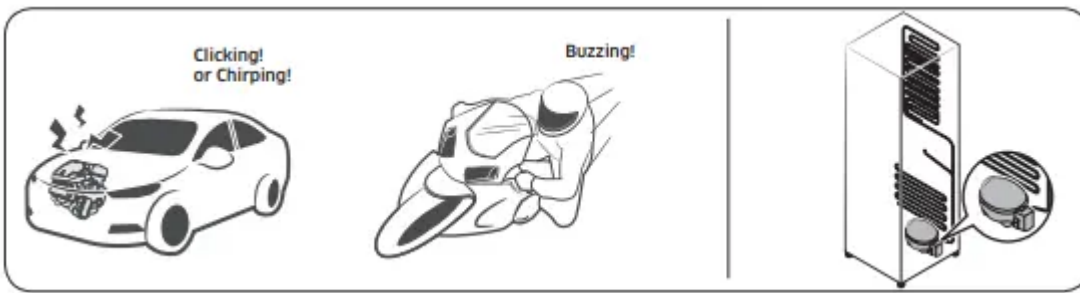

- While the fan is operating, these sounds may occur. When the refrigerator reaches the set temperature, the fan sound will stop.



- During a defrost cycle, water may drip on the defrost heater, causing sizzling sounds.

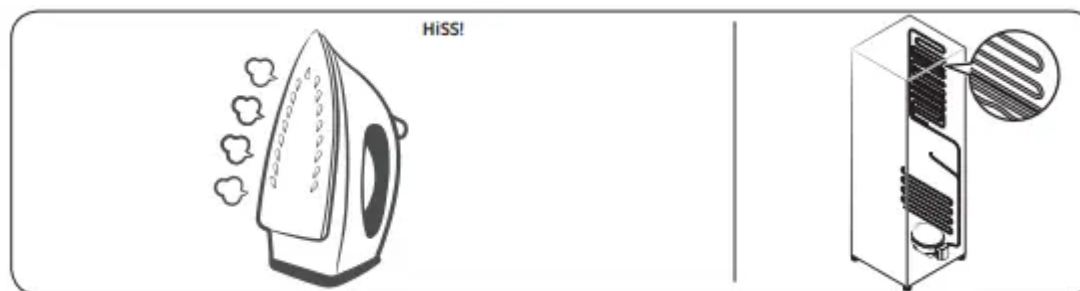

- As the refrigerator cools or freezes, refrigerant gas moves through sealed pipes, causing bubbling sounds. Bubbling!

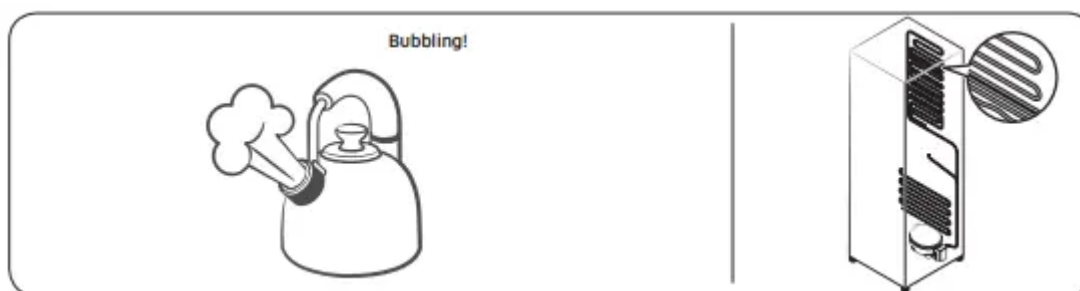

- As the refrigerator temperature increases or decreases, plastic parts contract and expand, creating knocking noises. These noises occur during the defrosting cycle or when electronic parts are working.

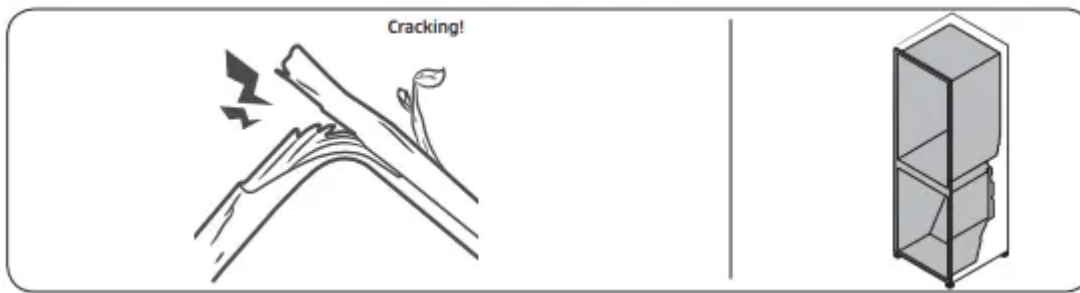

- For ice maker models: When the water valve opens to fill the ice maker, you may hear a buzzing sound.
- Due to pressure equalizing when you open and close the refrigerator door, you may hear a whooshing sound

SmartThings

Could not find "SmartThings" in the app market

- The SmartThings app is designed for Android 6.0 (Marshmallow) or later, iOS 10.0 or later, iPhone 6 or later, and is optimized for Samsung smartphones (Galaxy S and Galaxy Note series).

The SmartThings app fails to operate.

- The SmartThings app is available for applicable models only.
- The old Samsung Smart Refrigerator app cannot connect with Samsung Smart Home models.

The SmartThings app is installed but is not connected to my refrigerator.

- You must log into your Samsung account to use the app.
- Make sure that your router is operating normally.
- If you have not connected your refrigerator to the SmartThings App after the app was installed, you must make the connection using the device registration function of the app.

Could not log into the app.

- You must log into your Samsung account to use the app.
- If you don't have a Samsung account, follow the app's onscreen instructions to create one.

An error message appears when I try to register my refrigerator.

- Easy Connection may fail due to the distance from your access point (AP) or electrical interference from the surrounding environment. Wait a moment and try again.

The SmartThings app is successfully connected to my refrigerator but does not run.

- Exit and restart the SmartThings app or disconnect and reconnect the router.

- Unplug the power cord of the refrigerator, and then plug it in again after 1 minute.

Samsung Family Hub

Could not find "Samsung Family Hub" in the app market.

- The Samsung Family Hub app is available for smartphones that run Android 4.4 (KitKat) or higher, or iOS 8.0 or higher.

Could not log into the app.

- You must log into your Samsung account to use the app.
- If you don't have a Samsung account, follow the app's on screen instructions to create one.

Smart Grid (applicable models only)

What Do I Need to use the Energy Management and Smart Grid functions?

To use the Smart Grid (Demand Response) and Energy Management functions on your refrigerator, you need the following:

Devices

- A wireless access point (router)
- A Samsung Energy Management-supported refrigerator
- A smartphone

Registration

- Connect your refrigerator to your home Wi-Fi network.
- Register for the EMS service with your electric company. Your electric company must have an EMS (Energy Management System) supporting SEP (Smart Energy profile).

App

- Download the SmartThings app from the Google Play Store, Apple App Store, or Samsung Galaxy Apps.
- Install and run the SmartThings app on your smartphone.

Why isn't the Energy Management function working normally?

- Make sure that your home router is operating normally with proper Internet service and connection.
- Make sure that the refrigerator is connected to the AP (router).

Checkpoints

- Connect your smartphone to the router (AP, Access Point), and then check if you can browse the Internet on the smartphone.

Why isn't the Delay Defrost Capability working normally?

- Make sure that your home router is operating normally with proper Internet service and connection.

LCD

Cannot connect to my TV.

- This refrigerator can connect only with Samsung Smart TV series or higher models released since 2015. Please check the model name of your TV first.
- Network connections may suffer temporary interruptions. Turn your TV off, and then try again.

The inner view picture looks bulged out or incomplete.

- The edges of the inner view may look bulged out. The bulging is caused by the convex lens of the camera.
- The inner view may be incomplete due to the blind spots on the left and right corners or be screened depending on the layout of food items. Make sure to place food items in the front center.

The displayed measurement on the Fridge Manager is not correct.

- The displayed conditions may differ from the actual temperature and humidity.

Warning

This content is compiled from multiple sources and is provided for reference purposes only. It may not be complete or fully applicable to all situations. If you are unable to resolve your issue, please contact the product manufacturer or an authorized service provider for official support.