

## Operating Instructions

### About the features of your microwave oven.

Throughout this manual, features and appearance may vary from your model.

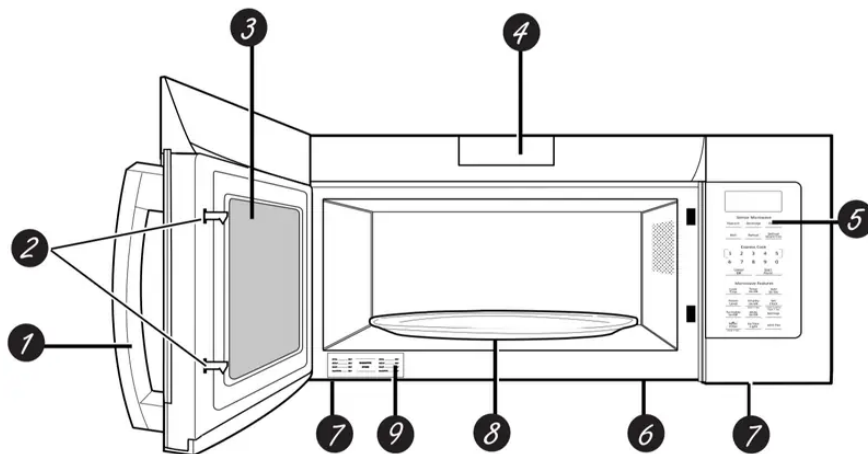

### Features of the Oven

1. **Door Handle.** Pull to open the door. The door must be securely latched for the microwave to operate.
2. **Door Latches.**
3. **Window with Metal Shield.** Screen allows cooking to be viewed while keeping microwaves confined in the oven.
4. **Charcoal Filter Door.** Push down two button to open the door. You can change charcoal filter easily.
5. **Touch Control Panel**
6. **Cooktop Light.**
7. **Grease Filter .**
8. **Removable Turntable.** Turntable and support **must** be in place when using the oven. The turntable may be removed for cleaning.
9. **Rating Plate.**

**NOTE:** Oven vent(s) and oven light are located on the inside walls of the microwave oven.

You can microwave by time, with the sensor features or with the auto feature. Not all features on all models.

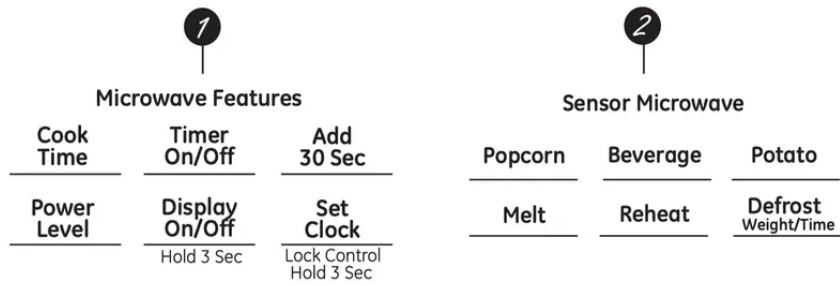

## Cooking Controls

Check the Convenience Guide before you begin.

<b>1</b>	<b>Time Features</b>	
<i>Press</i>	<i>Enter</i>	
<b>Cook Time</b>	Amount of cooking time	
<b>Defrost Weight/Time</b> <small>Press twice</small>	Amount of defrosting time	
<b>Melt</b>	Select melt food type (1-4)	
<b>Express Cook</b> <small>Press number pads (1-5)</small>	Starts Immediately!	
<b>Add 30 Sec</b>	Starts Immediately!	
<b>Power Level</b>	Power level 1 to 10	

<b>2</b>	<b>Sensor Features</b>		
<i>Press</i>	<i>Enter</i>	<i>Options</i>	
<b>Popcorn</b>	Starts immediately!	more/less time	
<b>Beverage</b>	Starts immediately!		
<b>Reheat</b>	Select reheat food type (1-4)	more/less time	
<b>Potato</b>	Starts Immediately!	more/less time	
<b>Defrost Weight/Time</b> <small>Press once</small>	Enter food weight	0.1 - 6.0 lbs.	

## Changing the Power Level.

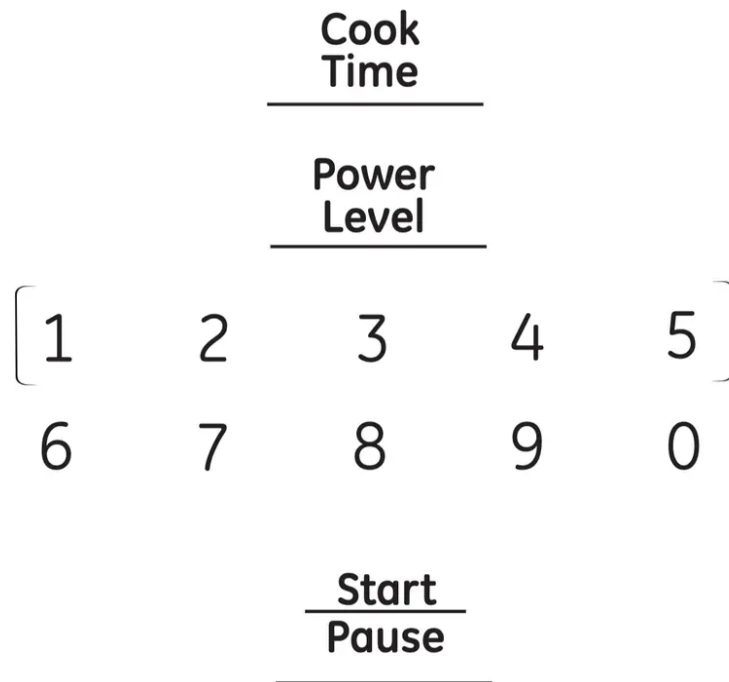

The power level may be entered or changed immediately after entering the feature time for **Cook Time, Time Defrost, Add 30 Sec** or **Express Cook**. The power level may also be changed during the time countdown.

1. Press **Cook Time.** or **Defrost Weight/Time** twice.
2. Enter cooking or defrosting time
3. Press **Power Level.**
4. Select desired power level **1-10.**
5. Press **Start/Pause.** Pressing **Start/Pause** is not necessary for **Express Cook** buttons.

Variable power levels add flexibility to microwave cooking. The power levels on the microwave oven can be compared to the surface units on a range. Each power level gives you microwave energy a certain percentage of the time. **Power level 7** is microwave energy 70% of the time. **Power level 3** is energy 30% of the time. Most cooking will be done on **High (power level 10)** which gives you 100% power.

**Power level 10** will cook faster but food may need more frequent stirring, rotating or turning over. A lower setting will cook more evenly and need less stirring or rotating of the food.

Some foods may have better flavor, texture or appearance if one of the lower settings is used. Use a lower power level when cooking foods that have a tendency to boil over, such as scalloped potatoes.

Rest periods (when the microwave energy cycles off) give time for the food to “equalize” or transfer heat to the inside of the food. An example of this is shown with **power level 3** - the defrost cycle. If

microwave energy did not cycle off, the outside of the food would cook before the inside was defrosted.

Here are some examples of uses for various power levels:

**Power Level 10:** Fish, bacon, vegetables, boiling liquids.

**Power Level 7:** Gentle cooking of meat and poultry; baking casseroles and reheating.

**Power Level 5:** Slow cooking and tenderizing for stews and less tender cuts of meat.

**Power Level 2 or 3:** Defrosting; simmering; delicate sauces.

**Power Level 1:** Keeping food warm; softening butter.

### About the time features.

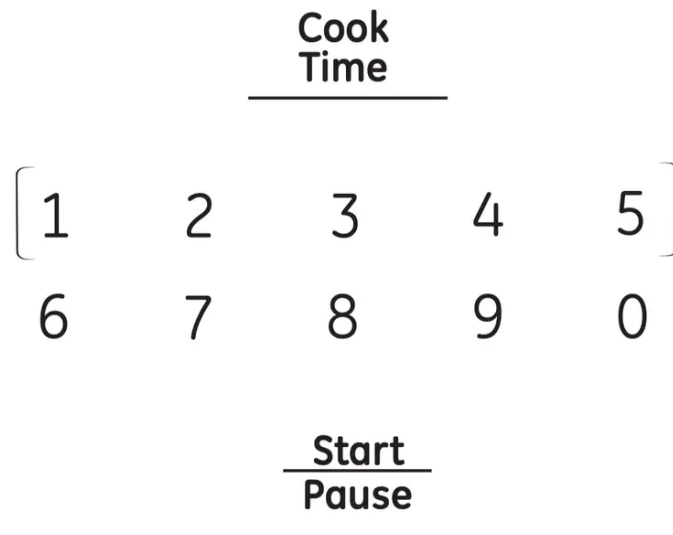

### Cook Time I

Allows you to microwave for any time up to 99 minutes and 99 seconds.

**Power level 10 (High)** is automatically set, but you may change it for more flexibility.

1. Press **Cook Time**.
2. Enter cooking time.
3. Change power level if you don't want full power. (Press **Power Level**. Select a desired power level 1–10.)
4. Press **Start/Pause**.

You may open the door during **Cook Time** to check the food. Close the door and press **Start/Pause** to resume cooking.

### Cook Time II



Lets you change power levels automatically during cooking. Here's how to do it.

1. Press **Cook Time**.
2. Enter the first cook time.
3. Change the power level if you don't want full power. (Press **Power Level**. Select a desired power level 1–10.)
4. Press **Cook Time** again.
5. Enter the second cook time.
6. Change the power level if you don't want full power. (Press **Power Level**. Select a desired power level 1–10.)
7. Press **Start/Pause**.

At the end of **Cook Time I**, **Cook Time II** counts down.

### **Cooking Guide for Cook Time**

**NOTE:** Use **power level 10** unless otherwise noted.



Vegetable	Amount	Time	Comments
<b>Asparagus</b> (fresh spears)	1 lb.	6 to 9 min.	In 1 1/2-qt. oblong glass baking dish, place 1/4 cup water. Rotate dish after half of time.
(frozen spears)	10-oz. package	5 to 7 min.	In 1-qt. casserole.
<b>Beans</b> (fresh green)	1 lb. cut in half	9 to 11 min.	In 1 1/2-qt. casserole, place 1/2 cup water.
(frozen green)	10-oz. package	6 to 8 min.	In 1-qt. casserole, place 2 tablespoons water.
(frozen lima)	10-oz. package	6 to 8 min.	In 1-qt. casserole, place 1/4 cup water.
<b>Beets</b> (fresh, whole)	1 bunch	17 to 21 min.	In 2-qt. casserole, place 1/2 cup water.
<b>Broccoli</b> (fresh cut)	1 bunch (1 1/4 to 1 1/2 lbs.)	7 to 10 min.	In 2-qt. casserole, place 1/2 cup water.
(fresh spears)	1 bunch (1 1/4 to 1 1/2 lbs.)	9 to 13 min.	In 2-qt. oblong glass baking dish, place 1/4 cup water. Rotate dish after half of time.
(frozen, chopped)	10-oz. package	5 to 7 min.	In 1-qt. casserole.
(frozen spears)	10-oz. package	5 to 7 min.	In 1-qt. casserole, place 3 tablespoons water.
<b>Cabbage</b> (fresh)	1 medium head (about 2 lbs.)	8 to 11 min.	In 1 1/2- or 2-qt. casserole, place 1/4 cup water.
(wedges)		7 to 10 min.	In 2- or 3-qt. casserole, place 1/4 cup water.
<b>Carrots</b> (fresh, sliced)	1 lb.	7 to 9 min.	In 1 1/2-qt. casserole, place 1/4 cup water.
(frozen)	10-oz. package	5 to 7 min.	In 1-qt. casserole, place 2 tablespoons water.
<b>Cauliflower</b> (flowerets)	1 medium head	9 to 14 min.	In 2-qt. casserole, place 1/2 cup water.
(fresh, whole)	1 medium head	10 to 17 min.	In 2-qt. casserole, place 1/2 cup water.
(frozen)	10-oz. package	5 to 7 min.	In 1-qt. casserole, place 2 tablespoons water.
<b>Corn</b> (frozen kernel)	10-oz. package	5 to 7 min.	In 1-qt. casserole, place 2 tablespoons water.
<b>Corn on the cob</b> (fresh)	1 to 5 ears	3 to 4 min. per ear	In 2-qt. oblong glass baking dish, place corn. If corn is in husk, use no water; if corn has been husked, add 1/4 cup water. Rearrange after half of time.
(frozen)	1 ear 2 to 6 ears	5 to 6 min. 3 to 4 min. per ear	Place in 2-qt. oblong glass baking dish. Cover with vented plastic wrap. Rearrange after half of time.
<b>Mixed vegetables</b> (frozen)	10-oz. package	5 to 7 min.	In 1-qt. casserole, place 3 tablespoons water.
<b>Peas</b> (fresh, shelled)	2 lbs. unshelled	9 to 12 min.	In 1-qt. casserole, place 1/4 cup water.
(frozen)	10-oz. package	5 to 7 min.	In 1-qt. casserole, place 2 tablespoons water.
<b>Potatoes</b> (fresh, cubed, white)	4 potatoes (6 to 8 oz. each)	9 to 12 min.	Peel and cut into 1 inch cubes. Place in 2-qt. casserole with 1/2 cup water. Stir after half of time.
(fresh, whole, sweet or white)	1 (6 to 8 oz.)	3 to 4 min.	Pierce with cooking fork. Place in the oven, 1 inch apart, in circular arrangement. Let stand 5 minutes.
<b>Spinach</b> (fresh)	10 to 16 oz.	5 to 7 min.	In 2-qt. casserole, place washed spinach.
(frozen, chopped and leaf)	10-oz. package	5 to 7 min.	In 1-qt. casserole, place 3 tablespoons water.
<b>Squash</b> (fresh, summer and yellow)	1 lb. sliced	5 to 7 min.	In 1 1/2-qt. casserole, place 1/4 cup water.
(winter, acorn or butternut)	1 to 2 squash (about 1 lb. each)	8 to 11 min.	Cut in half and remove fibrous membranes. In 2-qt. oblong glass baking dish, place squash cut-side-down. Turn cut-side-up after 4 minutes.

## Time Defrost

## Defrost Weight/Time

[ 1    2    3    4    5 ]  
6    7    8    9    0

## Start Pause

Allows you to defrost for a selected length of time. See the Defrosting Guide for suggested times. (**Weight Defrost** explained in the About the Auto Feature section.)

1. Press **Defrost Weight/Time** twice.
2. Enter defrosting time.
3. Press **Start/Pause**.
4. Turn food over when the oven signals.
5. Press **Start/Pause**.

When the oven signals, turn food over and break apart or rearrange pieces for more even defrosting. Shield any warm areas with small pieces of foil. The oven will continue to defrost if you don't open the door and turn the food.

Power level is automatically set at 3, but can be changed. You can defrost small items quickly by raising the power level after entering the time. Power level 7 cuts the total defrosting time in about half; power level 10 cuts the total time to approximately 1/3. However, food will need more frequent attention than usual.

A dull thumping noise may be heard during defrosting. This is normal when oven is not operating at High power.

### **Defrosting Tips**

- Foods frozen in paper or plastic can be defrosted in the package. Closed packages should be slit, pierced or vented AFTER food has partially defrosted. Plastic storage containers should be partially uncovered.
- Family-size, prepackaged frozen dinners can be defrosted and microwaved. If the food is in a foil container, transfer it to a microwave-safe dish.

- Foods that spoil easily should not be allowed to sit out for more than one hour after defrosting. Room temperature promotes the growth of harmful bacteria.
- For more even defrosting of larger foods, such as roasts, use **Defrost Weight**. Be sure large meats are completely defrosted before cooking.
- When defrosted, food should be cool but softened in all areas. If still slightly icy, return to the microwave very briefly, or let it stand a few minutes counts down.

## Defrosting Guide

Food	Time	Comments
<b>Breads, Cakes</b> Bread, buns or rolls (1 piece) Sweet rolls (approx. 12 oz.)	1 min. 3 to 5 min.	Rearrange after half of time.
<b>Fish and Seafood</b> Fillets, frozen (1 lb.) Shellfish, small pieces (1 lb.)	6 to 8 min. 5 to 7 min.	Place block in casserole. Turn over and break up after first half of time.
<b>Fruit</b> Plastic pouch—1 or 2 (10-oz. package)	3 to 6 min.	
<b>Meat</b> Bacon (1 lb.) Franks (1 lb.)  Ground meat (1 lb.) Roast: beef, lamb, veal, pork Steaks, chops and cutlets	2 to 5 min. 2 to 5 min.  5 to 7 min. 12 to 16 min. per lb. 5 to 7 min. per lb.	Place unopened package in oven. Let stand 5 minutes after defrosting. Place unopened package in oven. Microwave just until franks can be separated. Let stand 5 minutes, if necessary, to complete defrosting. Turn meat over after first half of time. Use power level Warm (1). Place unwrapped meat in cooking dish. Turn over after first half of time and shield warm areas with foil. After second half of time, separate pieces with table knife. Let stand to complete defrosting.
<b>Poultry</b> Chicken, broiler-fryer, cut up (2 1/2 to 3 lbs.)  Chicken, whole (2 1/2 to 3 lbs.)  Cornish hen  Turkey breast (4 to 6 lbs.)	15 to 19 min.  17 to 21 min.  7 to 13 min. per lb. 5 to 9 min. per lb.	Place wrapped chicken in dish. Unwrap and turn over after first half of time. After second half of time, separate pieces and place in cooking dish. Microwave 2 to 4 minutes more, if necessary. Let stand a few minutes to finish defrosting. Place wrapped chicken in dish. After first half of time, unwrap and turn chicken over. Shield warm areas with foil. To complete defrosting, run cool water in cavity until giblets can be removed. Place unwrapped hen in oven breast-side-up. Turn over after first half of time. Run cool water in cavity until giblets can be removed. Place unwrapped breast in microwave-safe dish breast-side-down. After first half of time, turn breast-side-up and shield warm areas with foil. Defrost for second half of time. Let stand 1 to 2 hours in refrigerator to complete defrosting.

## About the time features.

### Express Cook



This is a quick way to set cooking time for 1 – 5 minutes.

Press one of the **Express Cook** pads (from 1 to 5) for 1 to 5 minutes of cooking at **power level 10**. For example, press the **2** pad for 2 minutes of cooking time.

The power level can be changed as time is counting down. Press **POWER LEVEL** and enter 1–10.

### Add 30 Seconds

# Add 30 Sec

---

You can use this feature two ways:

- It will add 30 seconds to the time counting down each time the pad is pressed.
- It can be used as a quick way to set 30 seconds of cooking time.

## Melt

# Melt

---

Use the Melt feature to melt certain preprogrammed foods:

1. Press **Melt**.
2. Press one of the Express Cook Pads (from 1 to 4) to select the food you wish to melt.

Press Pad	Food to melt
1	Butter
2	Caramel
3	Chocolate
4	Marshmallows

3. Enter an amount (from 1 to 4) for food selected:

Press Pad	Amount of food to melt
1	Butter 1/2 Stick
2	1 Stick
3	2 Sticks
1	Caramel 4 Oz.
2	8 Oz.
3	12 Oz.
4	16 Oz.

Press Pad	Amount of food to melt
1	Chocolate 4 Oz.
2	8 Oz.
3	12 Oz.
4	16 Oz.
1	Marshmallows 5 Oz.
2	8 Oz.
3	10 Oz.
4	16 Oz.

4. Press **Start/Pause** to start cooking.

The amount can be changed as time is counting down. Enter Express Cook pads (from 1 to 4).

**About the auto features.**

**Defrost**  
Weight/Time

[ 1    2    3    4    5 ]  
6    7    8    9    0

Start  
**Pause**

**Weight Defrost**



Weight defrost automatically sets the defrosting times and power levels to give even defrosting results for meats, poultry and fish weighing up to six pounds.

1. Press **Defrost Weight/Time** once.
2. Using the conversion guide, enter food weight. For example, press pads 1 and 2 for 1.2 pounds (1 pound, 3 ounces).
3. Press Start/Pause.

(Time Defrost is explained in the Time Features section.)

- Remove meat from package and place on microwave-safe dish.
- When the oven signals, turn the food over. Remove defrosted meat or shield warm areas with small pieces of foil.
- After defrosting, most meats need to stand 5 minutes to complete defrosting. Large roasts should stand for about 30 minutes

### Conversion Guide

<b>If the weight of food is stated in pounds and ounces, the ounces must be converted to tenths (.1) of a pound.</b>	
<b>Ounces</b>	<b>Pounds</b>
<b>1-2</b>	<b>.1</b>
<b>3</b>	<b>.2</b>
<b>4-5</b>	<b>.3</b>
<b>6-7</b>	<b>.4</b>
<b>8</b>	<b>.5</b>
<b>9-10</b>	<b>.6</b>
<b>11</b>	<b>.7</b>
<b>12-13</b>	<b>.8</b>
<b>14-15</b>	<b>.9</b>



## About the sensor features.

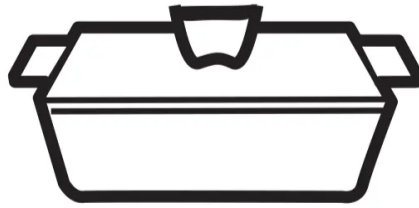

Covered



Vented



Dry off dishes so they don't mislead the sensor.

The Sensor Features detect the increasing humidity released during cooking. The oven automatically adjusts the cooking time to various types and amounts of food.

Do not use the Sensor Features twice in succession on the same food portion - it may result in severely overcooked or burnt food. Be sure to let the oven cool down for 5-10 minutes before starting the next sensor cook.

If food is undercooked after the countdown, use **Cook Time** for additional cooking time.

- The proper containers and covers are essential for best sensor cooking.
- **Always use microwave-safe containers and cover them with lids or vented plastic wrap. Never use tight-sealing plastic covers** - they can prevent steam from escaping and cause food to overcook.
- **Be sure the outside of the cooking container and the inside of the microwave oven are dry** before placing food in the oven. Beads of moisture turning into steam can mislead the sensor.

## Popcorn

# Popcorn

---

**NOTE:** Do not use this feature twice in succession on the same food portion - it may result in severely overcooked or burnt food.

**To use the Popcorn feature:**

1. Follow package instructions, using **Cook Time** if the package is less than 2.0 ounces or larger than 3.5 ounces. Place the package of popcorn in the center of the microwave.
2. Press **POPCORN**. The oven starts immediately. Tap **POPCORN** to select the bag size you are cooking.

If you open the door while “**POPCORN**” is displayed, “**SENSOR ERROR**” will appear. Close the door, press **CancelOff** and begin again.

If food is undercooked after the countdown use **Cook Time** for additional cooking time.

**How to Adjust the Popcorn Program to Provide a Shorter or Longer Cook Time**

If you find that the brand of popcorn you use underpops or overcooks consistently, you can add or subtract 10% to the automatic popping time.

To add time:

After pressing **POPCORN**, press **9** immediately after the oven starts for an extra 10% of the automatic popping time.

To subtract time:

After pressing **POPCORN**, press **1** immediately after the oven starts for 10% less of the automatic popping time.

**Beverage**

# Beverage

---

**NOTE:** Do not use this feature twice in succession on the same food portion - it may result in severely overcooked or burnt food.

**To use the Beverage feature:**

Press **BEVERAGE**. The oven starts immediately.

**Drinks heated with the Beverage feature may be very hot. Remove the container with care.**

If food is undercooked after the countdown, use **Cook Time** for additional cooking time.

## Reheat

# Reheat

---

### How to Change the Automatic Settings

**To reduce time by 10%:** Press **1** after the feature pad.

**To add 10% to cooking time:** Press **9** after the feature pad.

**NOTE:** Do not use this feature twice in succession on the same food portion - it may result in severely overcooked or burnt food.

### To use the Reheat feature:

The Reheat feature reheats single servings of previously cooked foods or a plate of leftovers.

1. Place covered food in the oven. Press **Reheat**.
2. Press one of the **Express Cook** pads (from 1 to 4) to select the food you wish to reheat.

Press Pad	Food to Reheat
1	Plate
2	Soup
3	Veggies
4	Pasta

3. The oven signals when steam is sensed and the time remaining begins counting down.

Do not open the oven door until time is counting down. If the door is opened, close it and press **Start/Pause** immediately.

**After removing food from the oven, stir, if possible, to even out the temperature. If the food is not hot enough, use Cook Time to reheat for more time. Reheated foods may have wide variations in temperature. Some areas may be extremely hot.**

If food is not hot enough after the countdown, use Cook Time for additional reheating time.

### Some Foods Not Recommended For Use With Reheat:

It is best to use Cook Time for these foods:

- Bread products.
- Foods that must be reheated uncovered.

- Foods that need to be stirred or rotated.
- Foods calling for a dry look or crisp surface after reheating.

## Potato

# Potato

---

### How to Change the Automatic Settings

**To reduce time by 10%:** Press **1** after the feature pad.

**To add 10% to cooking time:** Press **9** after the feature pad.

**NOTE:** Do not use this feature twice in succession on the same food portion - it may result in severely overcooked or burnt food.

1. Pierce potato skin with fork and place potato in the oven.
2. Press **Potato**. the oven starts immediately.
3. The oven signals when steam is sensed and time remaining is counting down. Turn or stir the food if necessary.

Do not open the oven door until time is counting down. If the door is opened, close it and press **Start/Pause** immediately.

If food is undercooked after the countdown, use **Cook Time** for additional cooking time.

### About other features.

#### Cooking Complete Reminder

To remind you that you have food in the oven, the oven will display “Food is Ready” and beep once a minute until you either open the oven door or press **Cancel/Off**.

## Set Clock

# Set Clock

---

Lock Control  
Hold 3 Sec

Press to enter the time of day or to check the time of day while microwaving.

1. Press **Set Clock**.
2. Enter time of day.
3. Press **Start** or **Set Clock**.

To check the time of day while microwaving, press **Set Clock**.

### Child Lock-Out

You may lock the control panel to prevent the microwave from being accidentally started or used by children.

To lock or unlock the controls, press and hold **Set Clock** for about three seconds. When the control panel is locked, **LOCKED** will appear in the display.

### Display On/Off

# Display On/Off

---

Hold 3 Sec

To turn the clock display on or off, press and hold **Display On/Off button** for about 3 seconds. The **Display On/Off** feature cannot be used while a cooking feature is in use.

### Timer On/Off

# Timer On/Off

---

**Timer On/Off** operates as a minute timer and can be used at any time, even when the oven is operating.

1. Press **TIMER ON/OFF**.
2. Enter time you want to count down.
3. Press **TIMER ON/OFF** to start.

When time is up, the oven will signal. To turn off the timer signal, press **TIMER ON/OFF**.

**NOTE:** The timer indicator will be lit while the timer is operating.

## Start/Pause

# Start Pause

---

**Start/Pause** In addition to starting many functions, **Start/Pause** allows you to stop cooking without opening the door or clearing the display. Press **Start/Pause** again to restart the oven.

## Steam Clean

# Steam Clean

---

Use **Steam Clean** for easy wiping inside with steam.

1. Press the **Steam Clean** button.
2. Put steam bowl with 1/4 cup of water.
3. Press the dial or **Start/Pause** to start.
4. After **Steam Clean**, remove Turntable and Turn Table Support and wipe out inside of oven cavity with paper towel or soft cloth

## Turntable

# Turntable On/Off

---

For best cooking results, leave the turntable on. It can be turned off for large dishes. Press **TURNTABLE** to turn the turntable on or off.

**Sometimes the turntable can become too hot to touch.** Be careful touching the turntable during and after cooking.

## Vent Fan

# Vent Fan

---

The vent fan removes steam and other vapors from surface cooking.

Press Vent Fan once for high fan speed, twice for low fan speed or a third time to turn the fan off.

## Surface Light

# Surface Light

---

Press to turn the surface light on or off.

On some models, there is a night light option.

Press **Surface Light** once for bright light, twice for the night light or three times to turn the light off.

## Mute

# Mute On/Off

---

The beeper sound level can be mute. Press **Mute On/Off**.

## Automatic Fan

An automatic fan feature protects the microwave from too much heat rising from the cooktop below it. It automatically turns on at low speed if it senses too much heat.

If you have turned the fan on you may find that you cannot turn it off. The fan will automatically turn off when the internal parts are cool. It may stay on for 30 minutes or more after the cooktop and microwave controls are turned off.

### Clock Mode

# Settings

---

You can change clock 12/24hrs display mode.

1. Press **Settings**.
2. Press **Express Cook** pad **1**.
3. Select 12hrs/24hrs.

**1** - 12 hrs

**2** - 24 hrs

### Display Speed

# Settings

---

You can change display speed.

1. Press **Settings**.
2. Press **Express Cook** pad **2**.
3. Select new display speed.

**1** - slow

**2** - normal

**3** - fast

### Sound Level

# Settings

---

You can change sound level.

1. Press **Settings**.
2. Press **Express Cook** pad **3**.
3. Select sound level.

- 0 - mute
- 1 - low
- 2 - normal
- 3 - loud

## Reset Filter Button

# Reset Filter

---

The light will illuminate after approximately 6 months of alert user to replace the charcoal filter (if used) and clean/replace the grease filters. Reset by push and hold 3 seconds.

## Microwave terms.

### Arcing

Arcing is the microwave term for sparks in the oven. Arcing is caused by:

- metal or foil touching the side of the oven.
- foil that is not molded to food (upturned edges act like antennas).
- metal such as twist-ties, poultry pins, gold-rimmed dishes.
- recycled paper towels containing small metal pieces.
- plates or dishes with a metallic trim or glaze with a metallic sheen.

### Covering

Covers hold in moisture, allow for more even heating and reduce cooking time.

Venting plastic wrap or covering with wax paper allows excess steam to escape.

### Shielding

In a regular oven, you shield chicken breasts or baked foods to prevent over-browning. When microwaving, you use small strips of foil to shield thin parts, such as the tips of wings and legs on poultry, which would cook before larger parts.

### Standing Time

When you cook with regular ovens, foods such as roasts or cakes are allowed to stand to finish cooking or to set.

Standing time is especially important in microwave cooking. Note that a microwaved cake is not placed on a cooling rack.

### Venting

After covering a dish with plastic wrap, you vent the plastic wrap by turning back one corner so excess steam can escape.

## Care and cleaning

### Helpful Hints



An occasional thorough wiping with a solution of baking soda and water keeps the inside fresh. Unplug the cord before cleaning any part of this oven.

### How to Clean the Inside

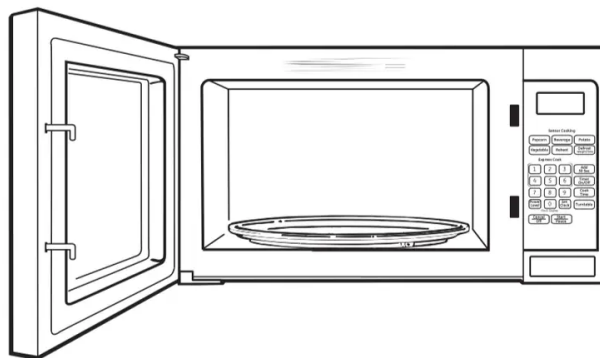

#### **Walls, Floor, Inside Window, Metal and Plastic Parts on the Door**

Some spatters can be removed with a paper towel, others may require a damp cloth. Remove greasy spatters with a sudsy cloth, then rinse with a damp cloth. Do not use abrasive cleaners or sharp utensils on oven walls.

To clean the surface of the door and the surface of the oven that come together upon closing, use only mild, nonabrasive soaps or detergents using a sponge or soft cloth. Rinse with a damp cloth and dry.

Never use a commercial oven cleaner on any part of your microwave.

## Removable Turntable and Turntable Support



To prevent breakage, do not place the turntable into water just after cooking. Wash it carefully in warm, sudsy water or in the dishwasher. The turntable and support can be broken if dropped. Remember, do not operate the oven without the turntable and support in place.

## How to Clean the Outside

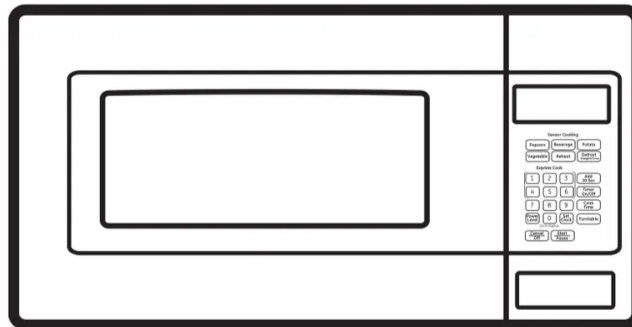

Do not use cleaners containing ammonia or alcohol on the microwave oven. Ammonia or alcohol can damage the appearance of the microwave.

### Case

Clean the outside of the microwave with a sudsy cloth. Rinse and then dry. Wipe the window clean with a damp cloth.

### Control Panel and Door

Wipe with a damp cloth. Dry thoroughly. Do not use cleaning sprays, large amounts of soap and water, abrasives or sharp objects on the panel - they can damage it. Some paper towels can also scratch the control panel.

### Door Surface

It's important to keep the area clean where the door seals against the microwave. Use only mild, non-abrasive detergents applied with a clean sponge or soft cloth. Rinse well.

### Stainless Steel

Do not use a steel-wool pad, it will scratch the surface.

To clean the stainless steel surface, use a hot, damp cloth with a mild detergent suitable for stainless steel surfaces. Use a clean, hot, damp cloth to remove soap. Dry with dry, clean cloth. Always scrub lightly in the direction of the grain.

### Power Cord

If the power cord becomes soiled, unplug and wash with a damp cloth. For stubborn spots, sudsy water may be used, but be certain to rinse with a damp cloth and dry thoroughly before plugging cord into outlet.

### Cooktop Light/Night Light Replacement

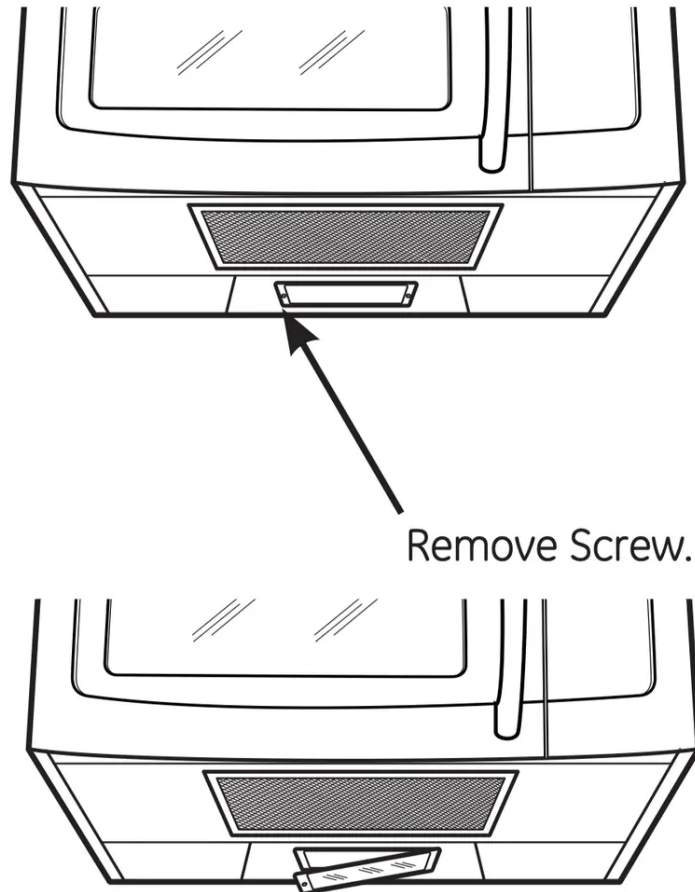

Replace the burned-out bulb with a 120 volt, 20-watt halogen bulb (WB36X10213), available from your GE supplier.

1. To replace the bulb(s), first disconnect the power at the main fuse or circuit breaker panel or pull the plug.
2. Remove the screw at the left of the light cover and lower the cover.
3. Be sure the bulb(s) to be replaced are cool before removing. After breaking the adhesive seal, remove the bulb by gently pulling. Replace with the same size and type bulb.
4. Replace the screw. Connect electrical power to the oven.

### Oven Light Replacement

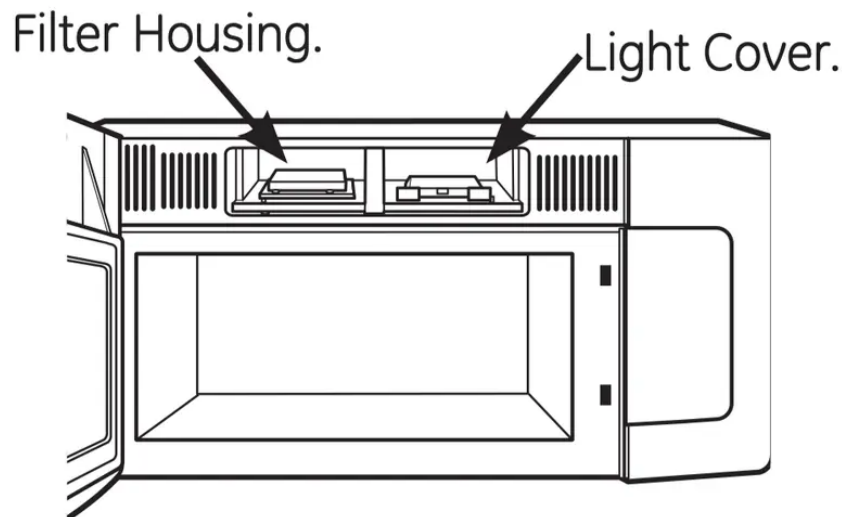
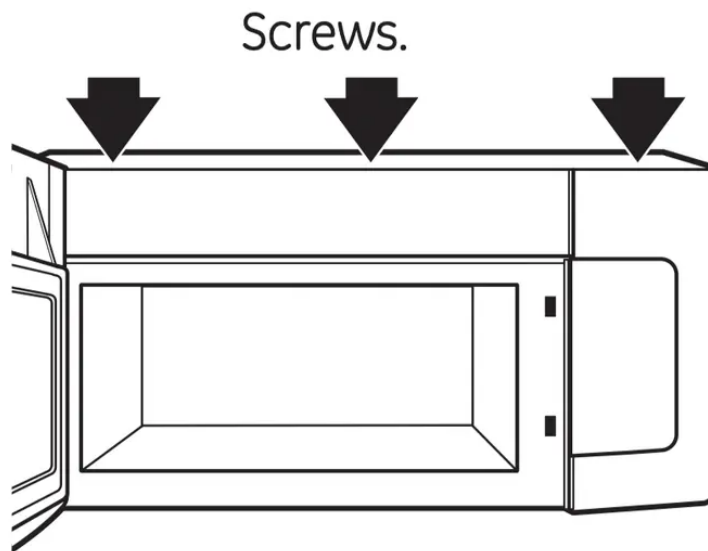

1. To replace the oven light, first disconnect the power at the main fuse or circuit breaker panel or pull the plug.
2. To remove the top grille, open the door and remove the 3 screws on top of the oven that hold the grille into place. Slide the grille to the left to remove it.
3. Lift the metal tab on the light cover located above the handle.
4. After breaking the adhesive seal, remove the bulb by gently turning. Replace with the same size and type bulb.
5. Replace the light cover.
6. Replace the grille and screws. Connect electrical power to the oven.

### Vent Fan

## Charcoal Filter

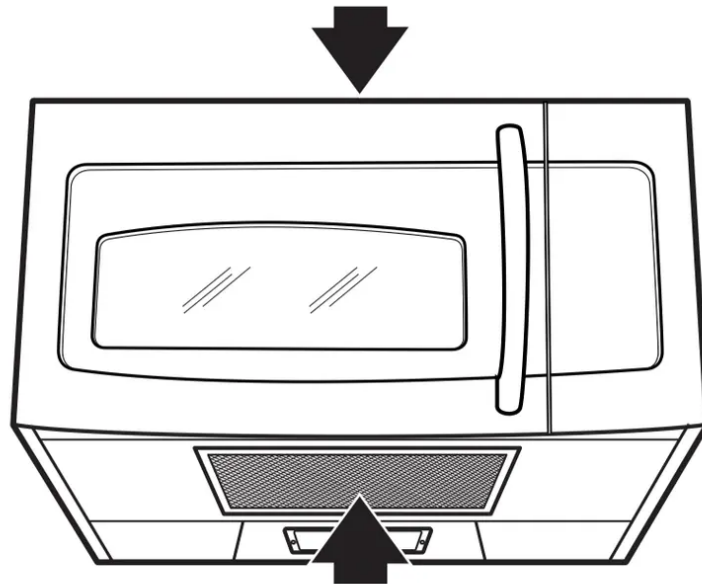

## Reusable Grease Filter

The vent fan has a metal reusable grease filter.

Models that recirculate air back into the room also use a charcoal filter.

### **Reusable Grease Filter**

The reusable grease filter traps grease released by foods on the cooktop. It also prevents flames from foods on the cooktop from damaging the inside of the microwave.

For this reason, the filter must ALWAYS be in place when the hood is used. The grease filter should be cleaned once a month, or as needed.

Replacement filters: WB06X10596

### **Removing and Cleaning the Filter**

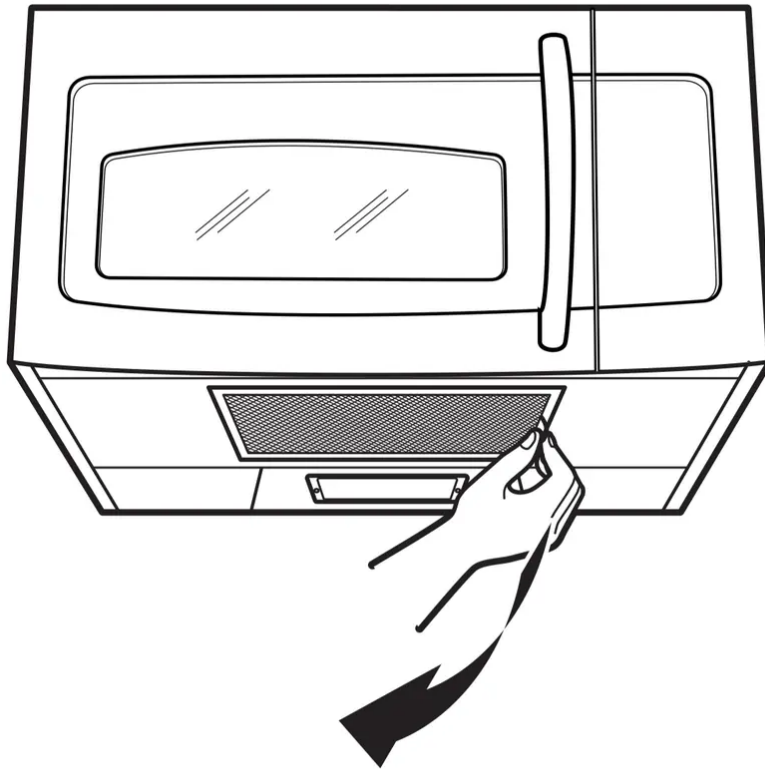

**To remove**, slide it to the side using the tab. Pull it down and out.

**To clean the grease filter**, soak it and then swish it around in hot water and detergent. Don't use ammonia or ammonia products because it will darken the metal. Light brushing can be used to remove embedded dirt.

Rinse, shake and let it dry before replacing.

**To replace**, slide the filter in the frame slot on the left side of the opening. Pull up and to the right to lock into place.

### **Charcoal Filter**

The charcoal filter cannot be cleaned.

It must be replaced. Order Part No. JX81J (sales number) or WB02X1124 (service number) from your GE supplier.

If the model is not vented to the outside, the air will be recirculated through a disposable charcoal filter that helps remove smoke and odors.

The charcoal filter should be replaced when it is noticeably dirty / discolored (usually after 6-12 months, depending on hood usage) or filter replacement LED is on. See "Optional Kits" for more information.

### **To Remove Charcoal Filter**

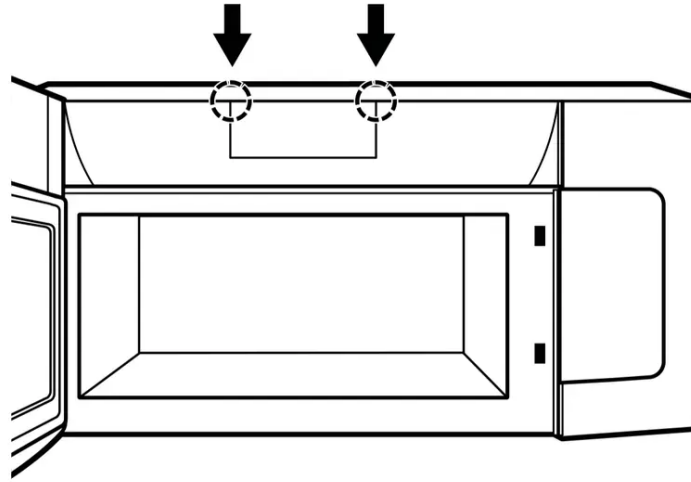

To remove the charcoal filter, disconnect power at the main fuse or circuit breaker panel or pull the plug.

Push down 2 buttons on the filter door upper to open.

Push the filter at the bottom until it comes free of the locking tabs. Slide the filter down and out.

Filter Housing.

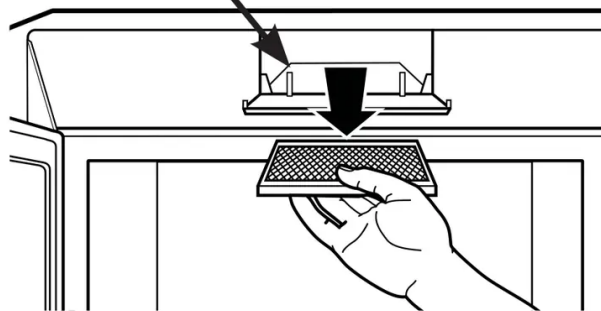

### To Install Charcoal Filter

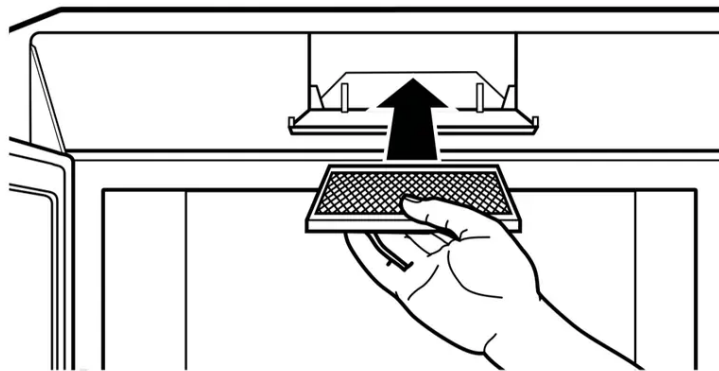

To install a new filter, remove plastic and other outer wrapping from the new filter.

Insert the filter into the left side of the front top opening of the oven as shown. It will rest at an angle on 2 side support tabs and in front of the right rear tab. Close the filter door.

# TROUBLESHOOTING



Problem	Possible Cause	What to Do
Oven will not start	<p>A fuse in your home may be blown or the circuit breaker tripped.</p> <p>Power surge.</p> <p>Plug not fully inserted wall outlet.</p> <p>Door not securely closed.</p>	<ul style="list-style-type: none"> <li>• Replace fuse or reset circuit breaker.</li> <li>• Unplug the microwave oven, then plug it back in.</li> <li>• Make sure the 3-prong plug on the into oven is fully inserted into wall outlet.</li> <li>• Open the door and close securely.</li> </ul>
Floor of the oven is warm, even when the oven has not been used	Heat from the cooktop light may make the oven floor get warm.	<ul style="list-style-type: none"> <li>• This is normal.</li> </ul>
"LOCKED" on display	The control has been locked.	<ul style="list-style-type: none"> <li>• Press and hold Set Clock for about 3 seconds to unlock the control.</li> </ul>
You hear an unusual, low-tone beep	<p>You have tried to start the Reminder without a valid time of day.</p> <p>You have tried to change the power level when it is not allowed.</p>	<ul style="list-style-type: none"> <li>• Start over and enter a valid time of day.</li> <li>• Many of the oven's features are preset and cannot be changed.</li> </ul>
"SENSOR ERROR" appears on display	<p>When using a Sensor feature, the door was opened before steam could be detected.</p> <p>Steam not detected in maximum amount of time.</p>	<ul style="list-style-type: none"> <li>• Do not open door until steam is sensed and time is shown counting down on display.</li> <li>• Use Time Cook to heat for more time.</li> </ul>

Problem	Possible Cause	What to Do
Food amount too large for Sensor Reheat	Sensor Reheat is for single servings of recommended foods.	<ul style="list-style-type: none"> <li>• Use Time Cook for large amounts of food.</li> </ul>

### Things That Are Normal With Your Microwave Oven

- Steam or vapor escaping from around the door.
- Light reflection around door or outer case.
- Dimming oven light and change in the blower sound at power levels other than high.
- Dull thumping sound while oven is operating.
- TV/radio interference might be noticed while using the microwave. Similar to the interference caused by other small appliances, it does not indicate a problem with the microwave. Plug the microwave into a different electrical circuit, move the radio or TV as far away from the microwave as possible, or check the position and signal of the TV/ radio antenna.

#### Warning

This content is compiled from multiple sources and is provided for reference purposes only. It may not be complete or fully applicable to all situations. If you are unable to resolve your issue, please contact the product manufacturer or an authorized service provider for official support.