

UNIT FEATURES

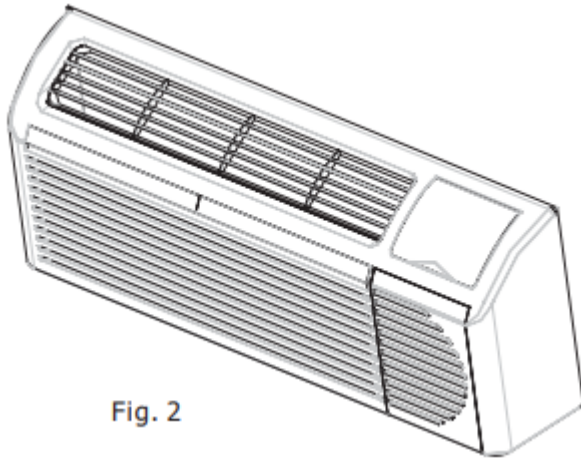

Fig. 2

This unit has many exciting features which are different from those found on standard PTAC models. The owner must be familiar with these features in order to fully understand the operation and capability of the unit.

- Intelligence -- Your unit has an on board computer that utilizes real time diagnostics to prolong the life of your unit. There is an LED indicator on the control board, behind the front panel, that will flash an error code if the unit has detected some kind of faulty condition. In many cases, the unit will automatically clear the fault condition and continue operating with no interruption. In some cases, the condition cannot be cleared and the unit will require service. In those cases, an "Fx" failure mode will be displayed on the digital display. For a detailed list of all error codes and "Fx" conditions, see Table 5 (page12) - Status LED Indicator Definitions for further details.
- Memory -- Your unit also has memory. If power is lost, all of the control settings (setpoint, mode, fan speed, on/off and configuration) are remembered. So when power is restored, the unit will start back up in the mode (and configuration) it was in, when power was lost.
- Quiet Design -- Not only does the unit have 2 fan motors and a tangential blower wheel for optimum sound, the indoor fan will always run a minimum of 10 seconds before the compressor, to help reduce the sound of the compressor starting.
- Random Compressor Restart -- To help prevent power surges after a power outage (many PTACs starting at the same time), the compressor is equipped with a 2 minute 45 second to 3 minute 15 second random restart delay feature. Whenever the unit is plugged in, or power has been restarted, a random compressor restart will occur to help avoid power surges. Compressor Protection -- To prevent short cycling of the compressor and maximize it's life, there is a random start--up delay of 3 minutes on the compressor and a minimum compressor run time of 3 minutes.

- Automatic Room Freeze Protection -- This protection feature will automatically ensure the indoor temperature does not fall below freezing. When your PTAC is configured for freeze protection (which is the default condition), then whenever power is supplied to the unit, if the unit senses temperature below 40°F, the fan motor and electric heater are turned on and will warm the room to 50°F. Freeze protection can be switched off (please see page 9), change the configuration switch to turn the feature off (see section on unit configuration).
- Automatic Quick Warm--Up (for heat pump models only) -- If the room temperature falls to 5°F below the set point temperature, the reverse cycle heat is shut off and the electric strip heat is turned on for one cycle, until room temperature rises.
- Dual-8 Display and LED Display -- Two 8-segment nixie tubes, 13 LED indicators (They are HIGH, MED, LOW, AUTO, COOL, FAN, HEAT, ON/OFF, SETOPINT, INDOOR, STATUS and TIMER)
 1. Mode indicator display: When the air conditioner operates in a certain mode, the corresponding mode indicator will be lit;
 2. The ON/OFF indicator is in green when the controller is ON and in red when controller is OFF.
 3. Fan speed display: When air conditioner operates at high, medium, low or auto fan speed, the corresponding indicator will be lit.
 4. Dual-8 display: Ambient temperature can also be displayed in cooling and heating modes through setting the keypad. Under cooling or heating mode, the dual-8 will display the set temperature (the dual-8 will display indoor ambient temperature under fan mode).
 5. If the display data has three bits, the dual-8 will display “ten's digit”+ “unit's digit” at first and then display “BLANK”+ “hundred's digit”
- Fan Configure for Optimization of Selected Application -- The unit can be optimized to selected application by configuring the fan to run in continuous mode or cycle on and off with the compressor and electric heater (can be different for both heating and cooling modes). In cycle mode, the fan will continue to run after the compressor or electric heater stops in order to blow off any residual heat or cool left on coil.

SYSTEM CONFIGURATION

VENTILATION CONTROL

- The ventilation control lever is located at left side of unit, behind the front panel.

NOTE: The vent door shipping screw must be removed before using vent control lever. See Installation Instructions.

- When set at CLOSE, only the air inside the room is circulated and filtered. When set at OPEN, outdoor air will be drawn into room.
- Energy Tip: Keep the vent control at CLOSE. Room air will be filtered and circulated.

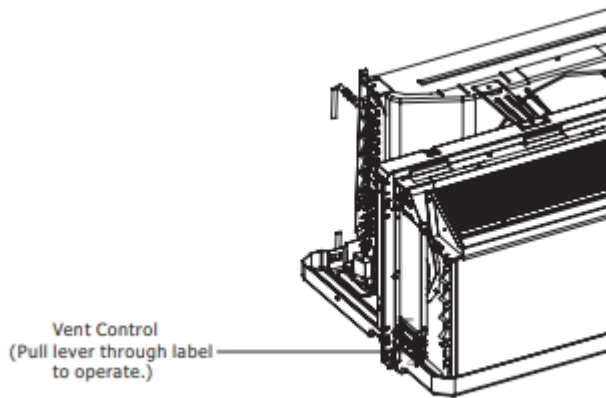
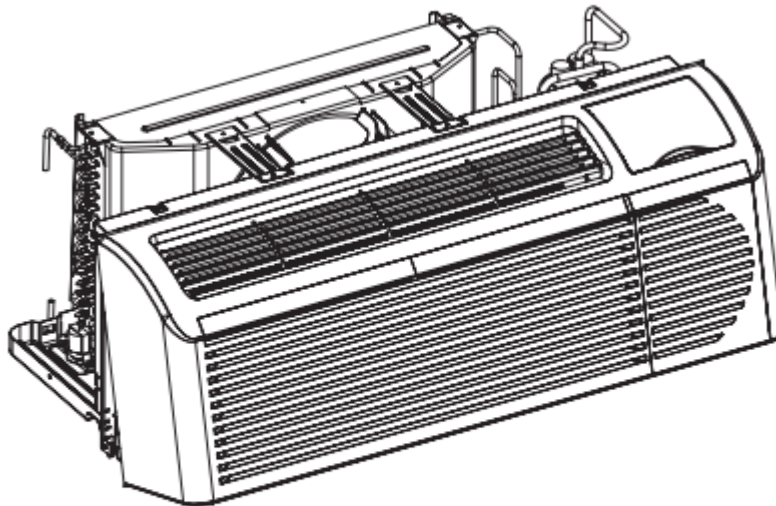

Fig. 13 – Ventilation Control Location

ADJUSTING AIR DIRECTION FOR DUCTED INSTALLATIONS ONLY

To adjust air direction:

1. Remove front panel. See Fig. 10.



Pull out at the bottom to release it from the tabs (1). Then lift up (2).

Fig. 10 – Removing Front Panel

2. Remove louver screws that hold louver insert in place (from back side of front panel).
See Fig. 14.

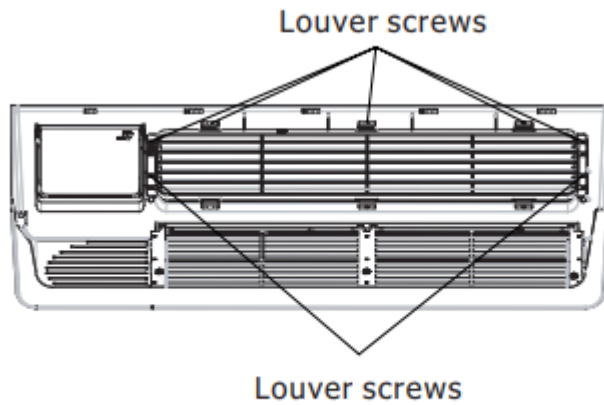

Fig. 14 – Backside of Front Panel

3. Turn louver insert and rotate 180°. See Fig. 18.

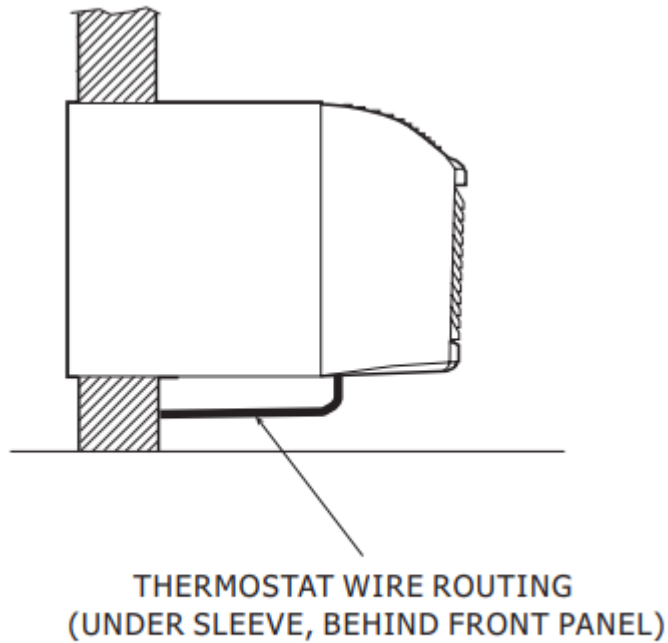

Fig. 18 – Proper Wire Routing Beneath Unit

4. Replace louver insert.
5. Replace screws and front panel.

NOTE: Upward air direction should only be used on ducted installations.

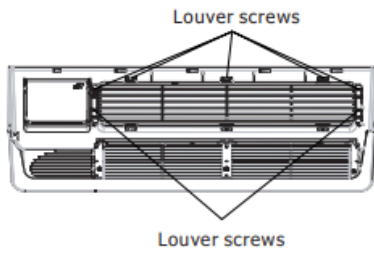

Fig. 14 – Backside of Front Panel

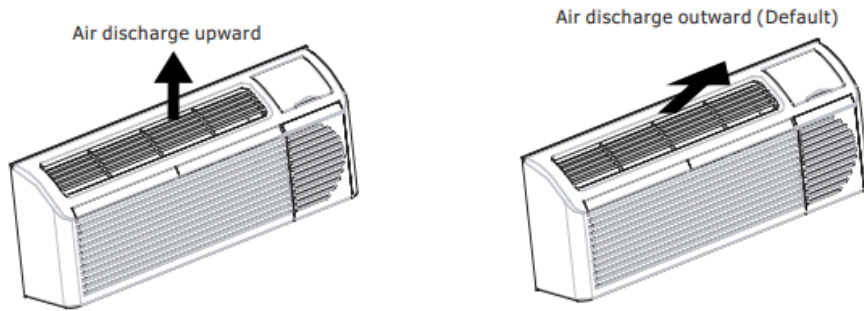
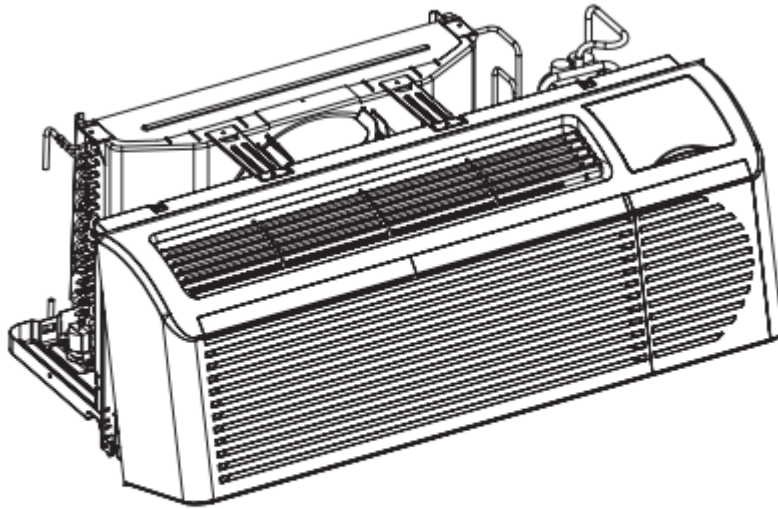

Fig. 15 – Adjusting Louvers

DIP SWITCHES

- Auxiliary dip switch controls are located behind the front panel, through an opening below the control panel.

- To access, remove front panel. See Fig. 10. Dip switches are accessible without opening the control box. Unit must be powered OFF to effectively change their status.



Pull out at the bottom to release it from the tabs (1). Then lift up (2).

Fig. 10 – Removing Front Panel

- Factory settings for dip switches will be in the DOWN position. See Table 4 - Dip Switch Functions for functions of each dip switch position.

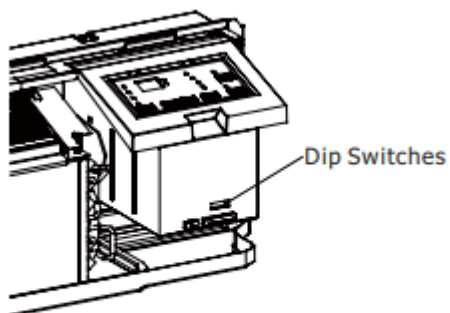

Fig.16 –Dipswitch Location on Unit

Dipswitch

Fig.16 –Dipswitch Location

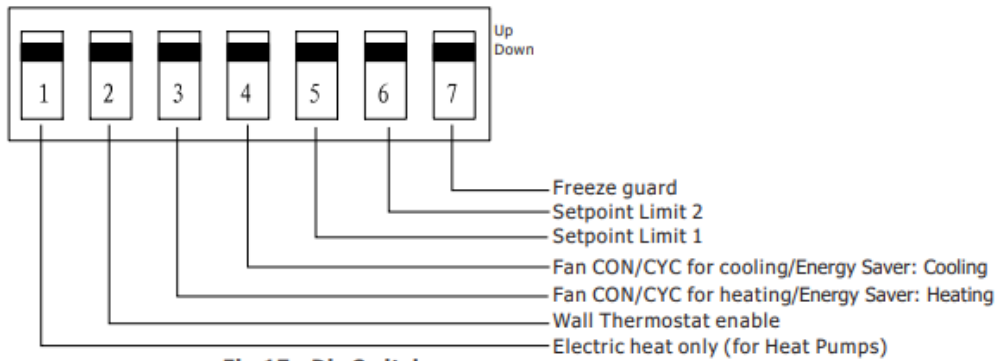

Fig.17 –Dip Switches

Table 4—DIP SWITCH FUNCTIONS

| No, | UP | | DOWN | | DEFAULT | REMARKS |
|-----|---------------------------------|-----------------------------------|-----------------------------------|---|-------------------------------------|---|
| 1 | Electric Heat Only | | Heat Pump | | DOWN | For Heat Pump unit only |
| 2 | Wall Thermostat Enable | | Control Panel Enable | | DOWN | |
| 3 | Fan Continuous Run for Heating | | Fan Cycle for Heat | | DOWN | |
| 4 | Fan Cycle for Cool | | Fan Continuous Run for Cooling | | DOWN | |
| 5*6 | UP*UP 68---75°F 20---24°C | UP*DOWN 63---80°F 18---28°C | DOWN*UP 65---78°F 19---26°C | DOWN*DOWN 61---86°F 16---30°C (full range) | DOWN*DOWN 61---86°F 16---30°C | Two configurations (5*6) Combine to select set point range. When set point limit set, display always shows full range. |
| 7 | Freeze Guard Disable | | Freeze Guard Enable | | DOWN | |

1.Electric Heating Only / Emergency Heat (For Heat Pump Units Only) This setting is typically used for Emergency Heating.

2.Wall Thermostat Enable A wired wall thermostat can be connected to the unit. The dip switch must be adjusted accordingly in order to allow the wall thermostat control of the unit. When in wall thermostat mode, the control panel will be disabled.

3*4.Energy Saver Dip Switches Allows the fan to operate in continuous or cycle modes while the unit is in heating or cooling mode (continuous or cycle): CON (Continuous) Allows fan to run continuously, circulating air even when the temperature setting has been satisfied. CYC (Cycle)/Energy Saver This setting allows the fan to cycle on and off with the compressor or electric heater. The fan stops a short time after the temperature setting is satisfied.This is the most efficient mode for electrical usage.

5*6.Setpoint Temperature Limits Provides a range of temperature control.

7.Room Freeze Protection If the unit senses a room temperature below 40°F, the fan motor and electric strip heat will turn on and warm the room to 50°F. The fan stops a short time after the temperature is satisfied.

KEYPAD CONFIGURATION

Keypad Configuration

- You can customize your unit additionally using the keypad configuration options.



To enter Keypad configuration

- Connect the unit to power. Press and hold the "fan speed" and the "V " for 5 continuous seconds, within 30 seconds of the unit being powered up. If the unit has had power for more than 30 continuous seconds, keypad configuration cannot be made.

To scroll through the Keypad Configuration Options

- Press and release the "fan speed" to select the keypad configurations.
- The stored value will be displayed.

To modify configuration settings

Press and release the Setpoint " ^ " or Setpoint " v " buttons.

To exit Keypad Configuration

Keypad Configuration will end on its own 30 seconds after the last button press or when the "mode" on the Keypad is pressed.

There are 4 configuration options+

1. Fahrenheit/Celsius Display Switch: Change between degrees Fahrenheit and Celsius on the display. An "F" indicates Fahrenheit display and 'C' indicates Celsius. Default is degrees "F".
2. Indoor Air Temperature Sensor Biasing for Cooling mode: Sometimes known as an anticipator, the air temperature sensor bias is used to adjust the room air temperature reading when in cooling mode. (Not normally required.)
3. Indoor Air Temperature Sensor Biasing for Heating mode: Sometimes known as an anticipator, the air temperature sensor bias is used to adjust the room air temperature reading when in heating mode. (Not normally required.)
4. Indoor Temperature Display: Change between showing the setpoint or desired temperature during heating and cooling modes (SP) or displaying the actual room temperature during heating and cooling modes (AA). SP mode is the default mode.
 - If SP is selected the desired setpoint temperature will be displayed during heating and cooling modes, regardless of what the actual temperature is in the room.
 - If AA mode is selected, the room temperature will be displayed during heating, cooling and fan only modes.
 - If the mode button has been changed to either heating or cooling modes, setpoint will be displayed for 10 seconds. After the 10 seconds, the room temperature will again be displayed.
 - If the on/off button is depressed (when the unit is off) and the last mode was either cooling or heating mode, the setpoint will be displayed for 10 seconds before displaying room temperature.

- During heating and cooling modes, if either the up or down setpoint key is depressed, the display will show the setpoint for 10 seconds. Then the room temperature will be displayed again.

Switchover between Emergency Auto Cooling Allowed and Emergency Auto Cooling Rejected:

- Press " " or " V " to switch between the display of Emergency Auto Cooling Allowed and Emergency Auto Cooling Rejected.
- Emergency Auto Cooling Allowed: the diode displays CA.
- Emergency Auto Cooling Rejected: the diode displays CD

Auto cooling operation:

- If this function is activated and room temperature reaches 85 F while the unit is in the "STOP" setting, the unit will automatically start in air conditioning operation and will shut off when the room temperature reach 80°F.

AUXILIARY CONTROLS

WALL THERMOSTAT TERMINAL

IMPORTANT: Only trained, qualified personnel should access the electrical panel on unit and install electrical accessories. Please contact your local electrical contractor, dealer, or distributor for assistance.

Thermostat Wire Routing

Thermostat wire is field supplied. Recommended wire gauge is 18 to 20 gauge solid thermostat wire.

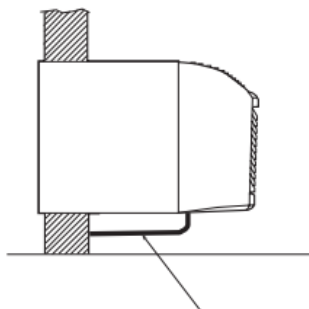

THERMOSTAT WIRE ROUTING
(UNDER SLEEVE, BEHIND FRONT PANEL)
Fig. 18 – Proper Wire Routing Beneath Unit

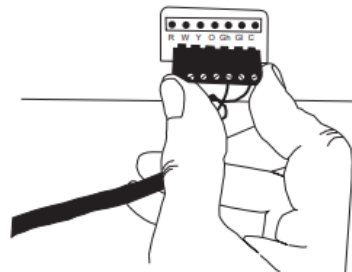

Fig. 19 –Terminal Connector Removal and Replacement

Wiring Thermostat

- To Unit Wire wall thermostat input as defined in Fig. 21.

NOTE: Terminal connector can be removed and replaced to simplify the wiring. See Fig.19.

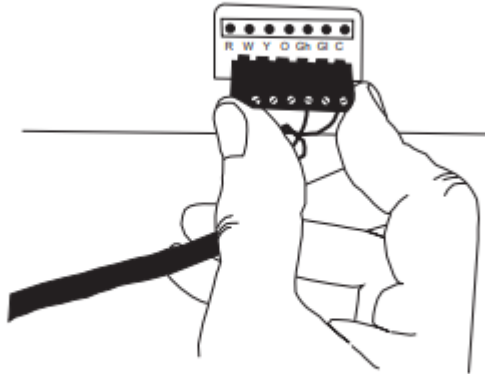

Fig. 19 –Terminal Connector Removal and Replacement

NOTE: For heat pump models, anytime there is a second-stage call for heating from the wall thermostat, the unit will automatically switch over to electric heating.

Install Thermostat Wiring

1. Check to be sure power to unit is disconnected.
2. Pull terminal connector to remove
NOTE: Terminal connector can be removed and replaced to simplify thermostat wiring.
3. Connect wires from the thermostat to terminals on unit terminal connector.
4. Reinstall terminal connector.
5. Ensure that unit is configured for wall thermostat enable.
6. Replace control panel label with control panel guard.
7. Restore power to unit.

NOTE: Refer to thermostat installation instructions for details on installing wall thermostat.

NOTE: For thermostats that have two fan speed output (Low fan or Hi fan), the fan speed is determined by how the terminal connector is wired. If Low fan is desired, wire the GL output from the thermostat to GL on the unit's terminal block. If Hi fan is desired, wire the GH output from the thermostat to GH on the unit's terminal block.

NOTE: After proper installation, if your thermostat is not working properly, refer to the Trouble Shooting section on page 17.

TERMINAL CONNECTIONS

The wall thermostat terminal block is located behind the front panel and is easily accessible on front of control panel.

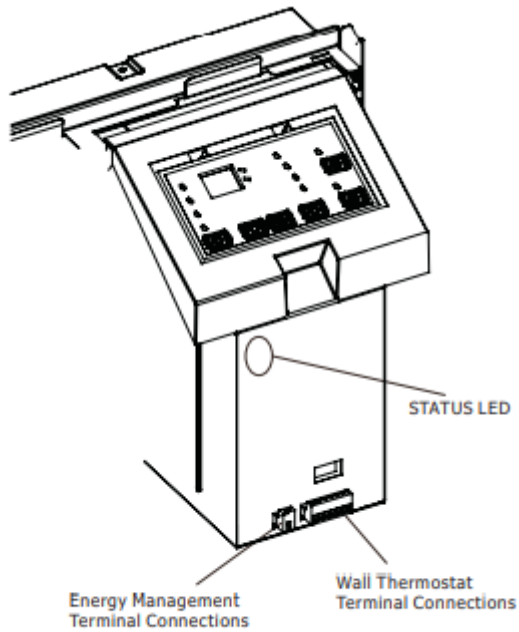
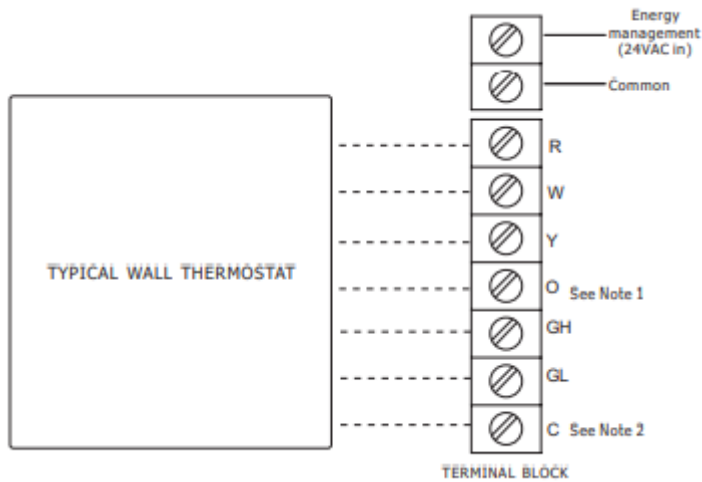

Fig.20– Terminal Connector and Status LED Location



NOTES

1. Use terminal "O" for heat pump connection only.
2. Terminal "C" (common) is typically only required for digital thermostats.

| TERMINAL | DESIGNATION |
|----------|-----------------|
| R | 24 VAC |
| W | Electric Heat |
| Y | Compressor |
| O | Reversing Valve |
| GH | High Fan |
| GL | Low Fan |
| C | Common |

NOTE: Any incorrect input combinations will be captured as thermostat wiring failures and will light the STATUS LED indicator on main board (see Intelligent Self - Checking Control section)

Fig.21–Wiring Connections

ENERGY MANAGEMENT INPUT (FRONT DESK CONTROL)

- The controller can handle a switch signal from remote energy management input, called EM signal or front desk control. Input must be 24VAC. If system receives a 24VAC signal, it will turn unit off; otherwise, the unit runs in normal control. This function will be disabled under Freeze Guard protection. See Fig. 20 and Fig. 21 for terminal connections.

INTELLIGENT SELF-CHECKING CONTROL

- Your Frigidaire PTAC has a computer on-board that continuously checks key components of the unit to ensure they are operating properly. Under normal operation, unit status indicator (STATUS, on main PCB), light is steadily ON. If there is a major problem, the unit will shut down and display a diagnostic failure code on the unit's display. If it is a minor error and the unit can correct it by itself, the diagnostic code will be flashed on the status LED that can easily be seen when the front panel is removed (see Fig.23). Failure STATUS codes are defined in the table below

Table 5—STATUS LED Indicator Definitions

| | | | |
|---|-----------------------------------|---|--|
| 1 | Indoor air temp sensor open/short | 8-segment display 'F1', with STATUS light flash 1 times and off 3 sec, repeat | NOTE: When status light is flashing, it will be ON for 1 seconds and OFF for another 1 seconds. |
| 2 | Indoor coil sensor open or short | 8-segment display 'F2', with STATUS light flash 2 times and off 3 sec, repeat | |
| 3 | Outdoor coil sensor open/short | 8-segment display 'F4', with STATUS light flash 3 times and off 3 sec, repeat | |
| 4 | Freeze Guard protection | 8-segment display 'FP' | |
| 5 | Indoor coil freeze protection | STATUS light flash 5 times and off 3 sec, repeat | |
| 6 | Outdoor coil high temp protection | STATUS light flash 6 times and off 3 sec, repeat | |
| 7 | Defrost (heat pump type) | STATUS light flash 7 times and off 3 sec, repeat | |
| 8 | Indoor coil high temp protection | STATUS light flash 8 times and off 3 sec, repeat | |
| 9 | Thermostat wiring error | STATUS light flash 9 times and off 3 sec, repeat | |

OPERATION

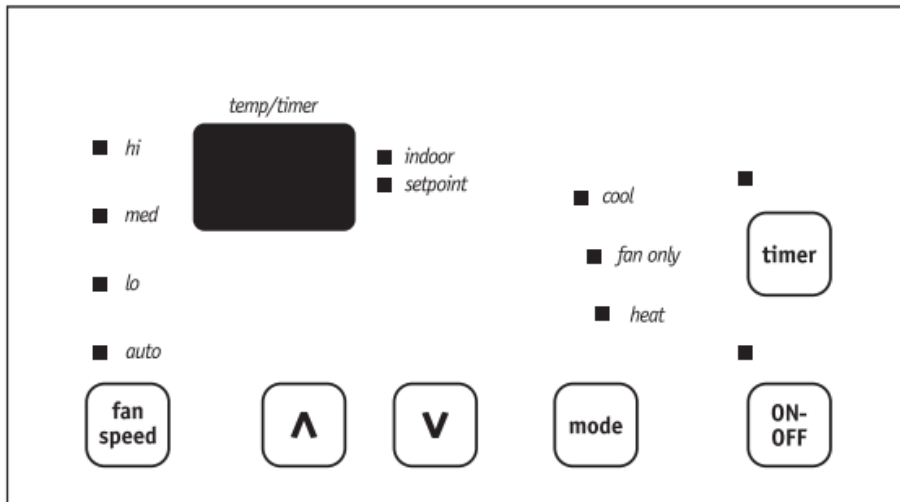

Fig. 22 – PTAC CONTROLS

About the controls on your unit

1. "ON-OFF" : It is used for turning ON/OFF the unit
2. "mode": It is used for switching between Cool, Fan and Heat mode
3. " ^ " is used for increasing temperature or timer setting
4. " v " is used for decreasing temperature or timer setting
5. "fan speed" +It is used for setting high, medium, low or auto fan speed. The corresponding LED will be lit when selected.
6. "timer" +It is used for setting timer function.
7. Timer function
 1. Timer ON: When the unit is off, timer ON can be set. Setting range is 0.5~24h. When timer ON time is reached, the system will operate according to the set mode.
 2. Timer OFF: When the unit is off, timer OFF can be set. Setting range is 0.5~24h. When timer OFF time is reached, the system will stop operation.
 3. Timer Setting: Press "timer " to set timer function and TIMER icon will be on. The time can be adjusted by pressing " ^ " or " v " buttons. The range of timer setting is from 0.5h to 24h. 5 seconds after timer setting, the timer function will be activated and TIMER icon will be on.
 4. Timer Preview: When timer function has been set, press "timer" to preview the remaining time of timer.

5. If Timer function has been set, turning on/off the unit or power failure will cancel timer setting.

CARE AND CLEANING

FRONT PANEL AND CASE

- Turn unit off and disconnect power supply. To clean, use water and a mild detergent. DO NOT use bleach or abrasives. Some commercial cleaners may damage the plastic parts.

OUTDOOR COIL

- Coil on outdoor side of unit should be checked regularly. Unit will need to be removed from its sleeve to inspect dirt build-up that can occur inside of the coil. If clogged with dirt or soot, coil should be professionally cleaned.

NOTE: Never use a high - pressure spray on coil.

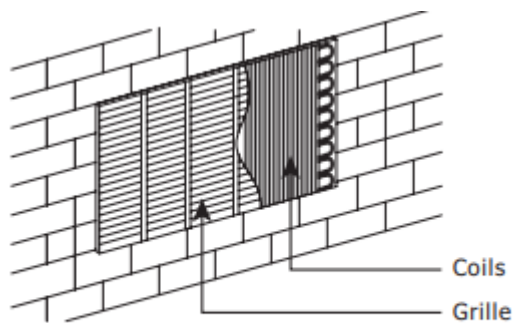

Clean inside and outside of outdoor coils regularly.

Fig. 23 – Outdoor Coil

CAUTION - UNIT DAMAGE HAZARD: Product failure due to improper care or lack of maintenance is not covered by warranty. Airflow restriction may cause damage to the unit.

BASE PAN

- Check base pan periodically and clean, if necessary.

AIR FILTERS

IMPORTANT: TURN UNIT OFF BEFORE CLEANING

CAUTION - UNIT DAMAGE HAZARD: Product failure due to improper care or lack of maintenance is not covered by warranty. Do not operate unit without filters in place. If a filter becomes torn or damaged, it should be replaced immediately. Operating without filters in place or with damaged filters will allow dirt and dust to reach indoor coil and reduce cooling, heating, airflow and efficiency of unit. Airflow restriction may cause damage to unit.

To maintain unit efficiency clean the filters at least every 30 days (or sooner depending on application). Clogged filters reduce cooling, heating and airflow.

Keeping filters clean will:

- Decrease cost of operation.
- Save energy.
- Prevent clogged indoor coil.
- Reduce risk of premature component failure.

To Clean Air Filters:

- Vacuum off heavy soil.
- Run water through filters.
- Dry thoroughly before replacing.

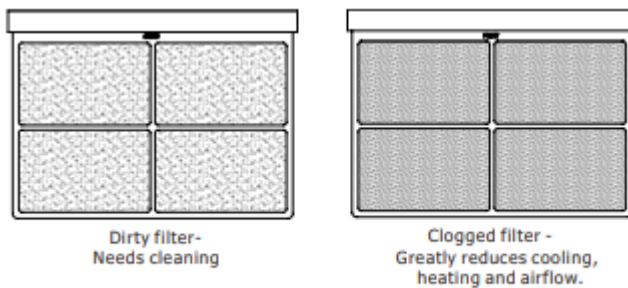
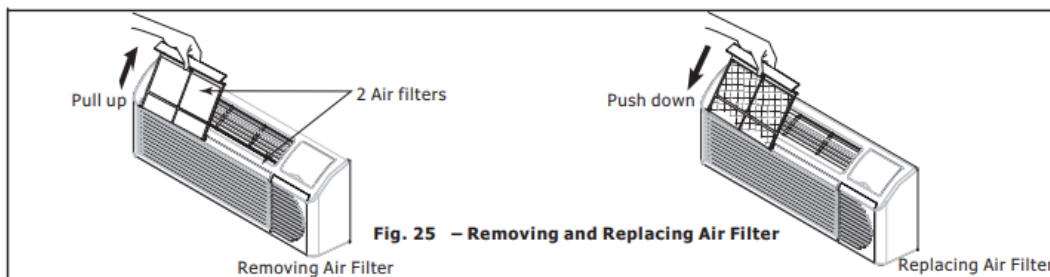

Fig. 24 – Identifying Clogged Filter



PREVENTATIVE MAINTENANCE

Preventative maintenance is essential to proper unit operation, efficiency and longevity.

To ensure equipment operates properly, it must be properly maintained. Equipment operation should be checked and verified several times during each year. During regular unit inspection and maintenance, follow the guidelines below:

- Clean both sides of outdoor coil. (Never use high pressure spray on coils.)
- Clean basepan and outdoor vent filter.
- Clean outdoor orifice and fan.

- Clean indoor coil. (Never use high pressure spray on coils.) C
- Clean indoor fan, wire screen and front panel.
- Clean or install new indoor - air inlet filter(s).
- Clean wall sleeve and outdoor grille.
- Inspect cord and receptacle.
- Secure electrical connections.
- Ensure front panel is properly mounted and not damaged.
- Ensure wall sleeve is installed properly.
- Ensure heat and cool cycles operate properly



TROUBLESHOOTING



| POSSIBLE CAUSES | SOLUTIONS |
|--|--|
| <p>UNIT DOES NOT START</p> <ul style="list-style-type: none"> • Unit may have become unplugged • Fuse may have blown Circuit breaker may have been tripped • Unit may be off or in wall thermostat mode. Check section on dipswitch settings to verify dipswitches are set properly. • Unit may be in a protection or diagnostic failure mode. See section on Intelligent Self---checking Control. | <ul style="list-style-type: none"> • Check that plug is plugged securely in wall receptacle. Note: Plug has a test/reset button on it. Make sure that the plug has not tripped. • Replace the fuse. See Note 1. • Reset circuit breaker. See Note 1. • Turn unit on (bottom right button on keypad). <p>Note: If the unit turns on, the LED will be green. If the unit is off, the LED will be red. If there is no LED on, there is a problem with power or damage to the control.</p> |
| <p>UNIT NOT COOLING/HEATING ROOM</p> <ul style="list-style-type: none"> • Unit air discharge section is blocked • Temperature setting is not high or low enough. Note: Set point limits may not allow the unit to heat or cool the room to the temperature desired. Check section on dipswitch settings. • Unit air filters are dirty. • Room is excessively hot or cold when unit is started. • Vent door left open. • Unit may be in a protection or diagnostic failure mode. Check section on Intelligent Self---checking Control. | <ul style="list-style-type: none"> • Make sure that curtains, blinds or furniture are not restricting or blocking unit airflow. • Reset to a lower or higher temperature setting. • Remove and clean filters. • Allow sufficient amount of time for unit to heat or cool the room. Start heating or cooling early before outdoor temperature, cooking heat or gatherings of people make room uncomfortable. • Close vent door. • Check dipswitch settings for desired comfort. <p>Wait approximately 3 minutes for compressor to start</p> |



| | |
|--|--|
| <ul style="list-style-type: none"> • Compressor is in time delay. There is a protective time delay (approx. 3 minutes) on starting the compressor after a power outage (or restarting after it has been turned off), to prevent tripping of the compressor overload. | |
| <p>DISPLAY HAS STRANGE NUMBERS/ CHARACTERS ON IT</p> | <ul style="list-style-type: none"> • The unit may be in a diagnostic condition. Check Intelligent SelfChecking Control section to determine if unit has had a failure. • The unit may be set for °C (instead of °F), see the keypad configuration section |
| <p>UNIT MAKING NOISES</p> | <ul style="list-style-type: none"> • Clicking, gurgling and whooshing noises are normal during operation of unit. |
| <p>WATER DRIPPING OUTSIDE</p> | <ul style="list-style-type: none"> • If a drain kit has not been installed, condensation runoff during very hot and humid weather is normal. See Note 2. If a drain kit has been installed and is connected to a drain system, check gaskets and fittings around drain for leaks and plugs. |
| <p>WATER DRIPPING INSIDE</p> <ul style="list-style-type: none"> • Wall sleeve is not installed level | <ul style="list-style-type: none"> • Wall sleeve must be installed level for proper drainage of condensation. Check that installation is level and make any necessary adjustments |
| <p>ICE OR FROST FORMS ON INDOOR COIL</p> <ul style="list-style-type: none"> • Low outdoor temperature | <ul style="list-style-type: none"> • When outdoor temperature is approximately 55 or below, frost may form on the indoor coil |

| | |
|---|---|
| <ul style="list-style-type: none"> • Dirty filters | <p>when unit is in Cooling mode. Switch unit to FAN operation until ice or frost melts.</p> <ul style="list-style-type: none"> • Remove and clean filters |
| <p>COMPRESSOR PROTECTION</p> <ul style="list-style-type: none"> • Power may have cycled, so compressor is in a restart protection | <ul style="list-style-type: none"> • Random Compressor restart- Whenever the unit is plugged in, or power has been restarted, a random compressor restart will occur. After a power outage, the compressor will restart after approximately 3 minutes. • Compressor Protection-To prevent short cycling of the compressor, there is a random startup delay of 3 minutes and a minimum compressor run time of 3 minutes. |

NOTES:

1. If circuit breaker is tripped or fuse is blown more than once, contact a qualified electrician.
2. If unit is installed where condensation drainage could drip in an undesirable location, an accessory drain kit should be installed and connected to drain system.

Warning

This content is compiled from multiple sources and is provided for reference purposes only. It may not be complete or fully applicable to all situations. If you are unable to resolve your issue, please contact the product manufacturer or an authorized service provider for official support.

