

CHARGE THE BATTERY

(1). Charge the battery equipped in the machine.

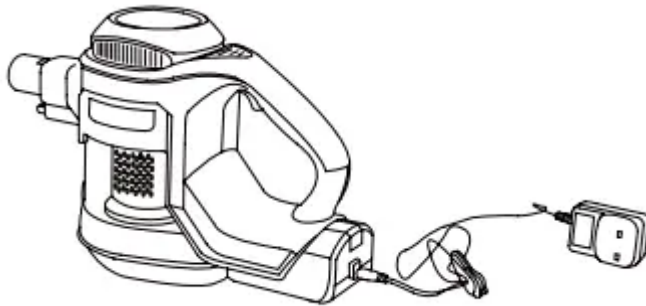

(2). Charge the battery alone.

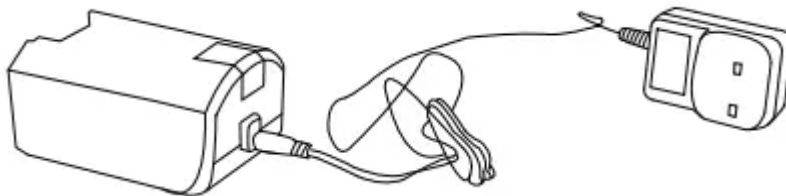

It's suggested to charge the battery when it's equipped in the machine to get informed by the LED indicator.

To be used after five hours charged, or referring to the indicator light when the battery is installed. Charging before batteries exhausted is recommended to prolong their life.

Battery indication during usage
Full Battery: 3 steady blue bars Insufficient Battery : Two or one blue bars Exhausted Battery: No significant lights
Battery indicator while charging
Charging : Blue bars increasing Not fully charged: Only two bars light is on, the third bar is still flashing Fully Charged: 3 steady blue bars

ASSEMBLY AND STORAGE

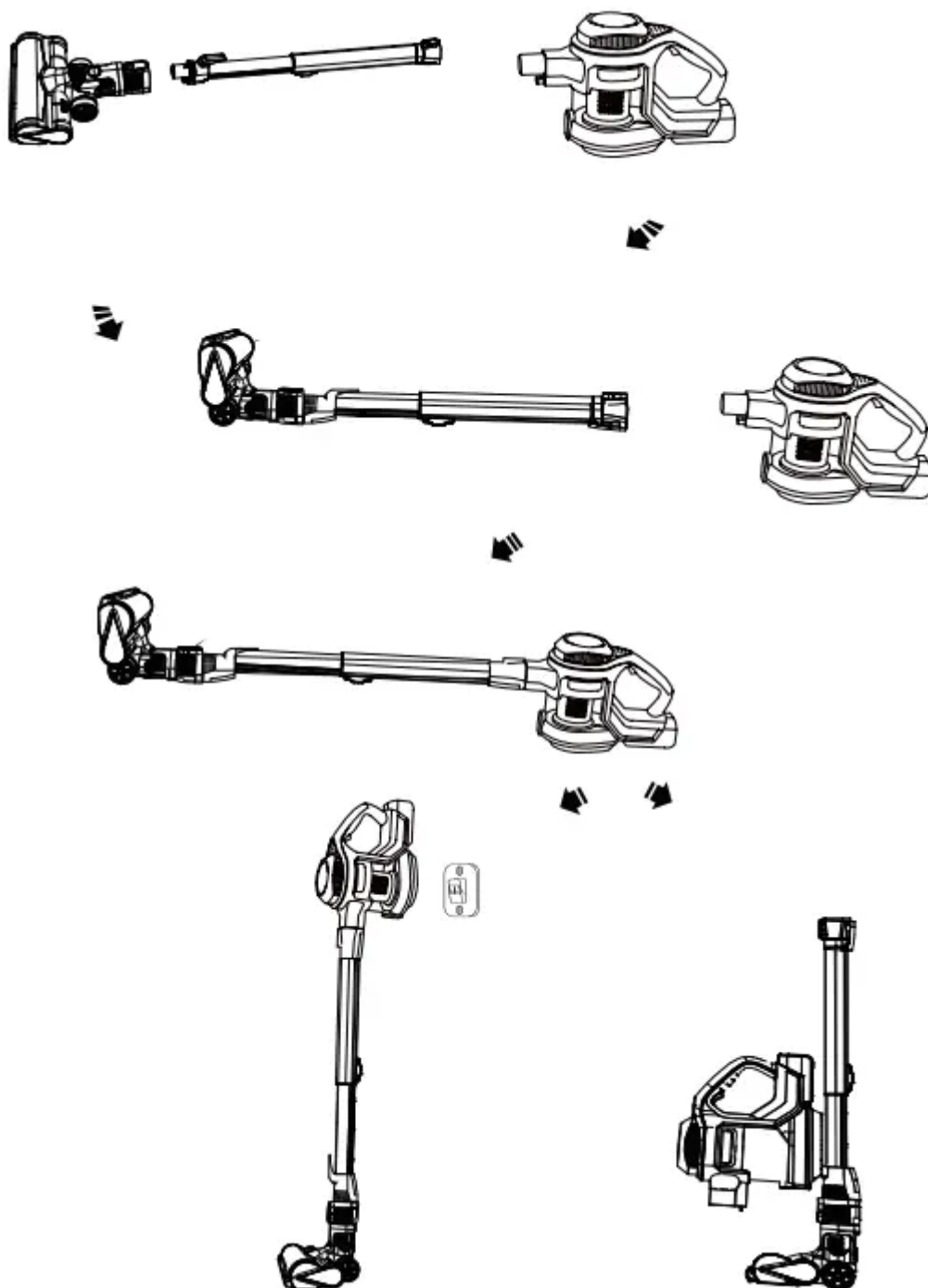

PRODUCT PARTS LIST AND SCHEMATIC

What's in box?

Please check if all the accessories are in the package box.

Name	Quantity
Cordless Vacuum	1
Adjustable Aluminum Alloy Tube	1
Electric Floor Brush	1
Two-in-one Dusting Brushing	1
Power Adapter	1
Warranty Card	1
User Manual	1
Gift Cleaning Brush	1
Wall Bracket	1



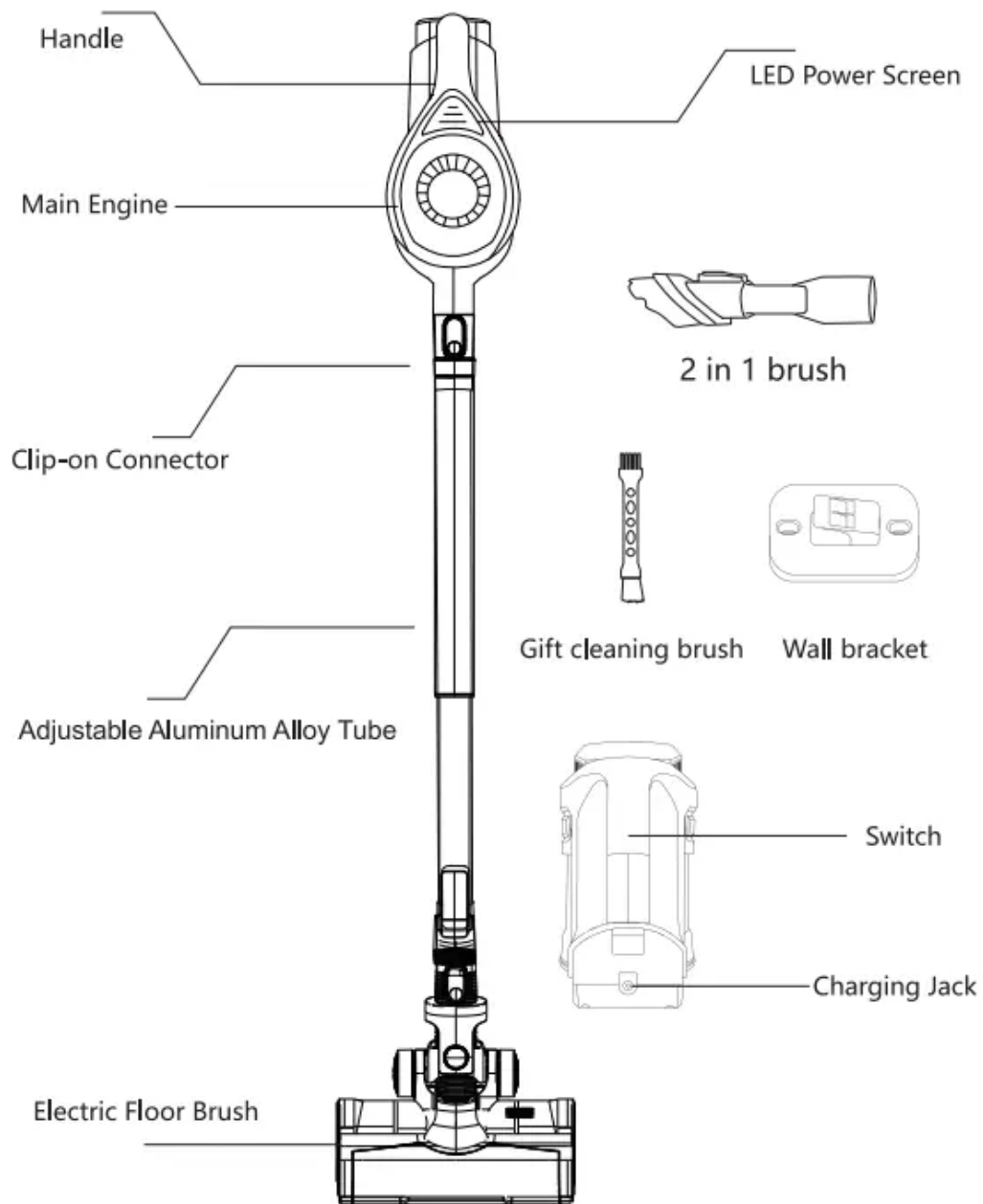

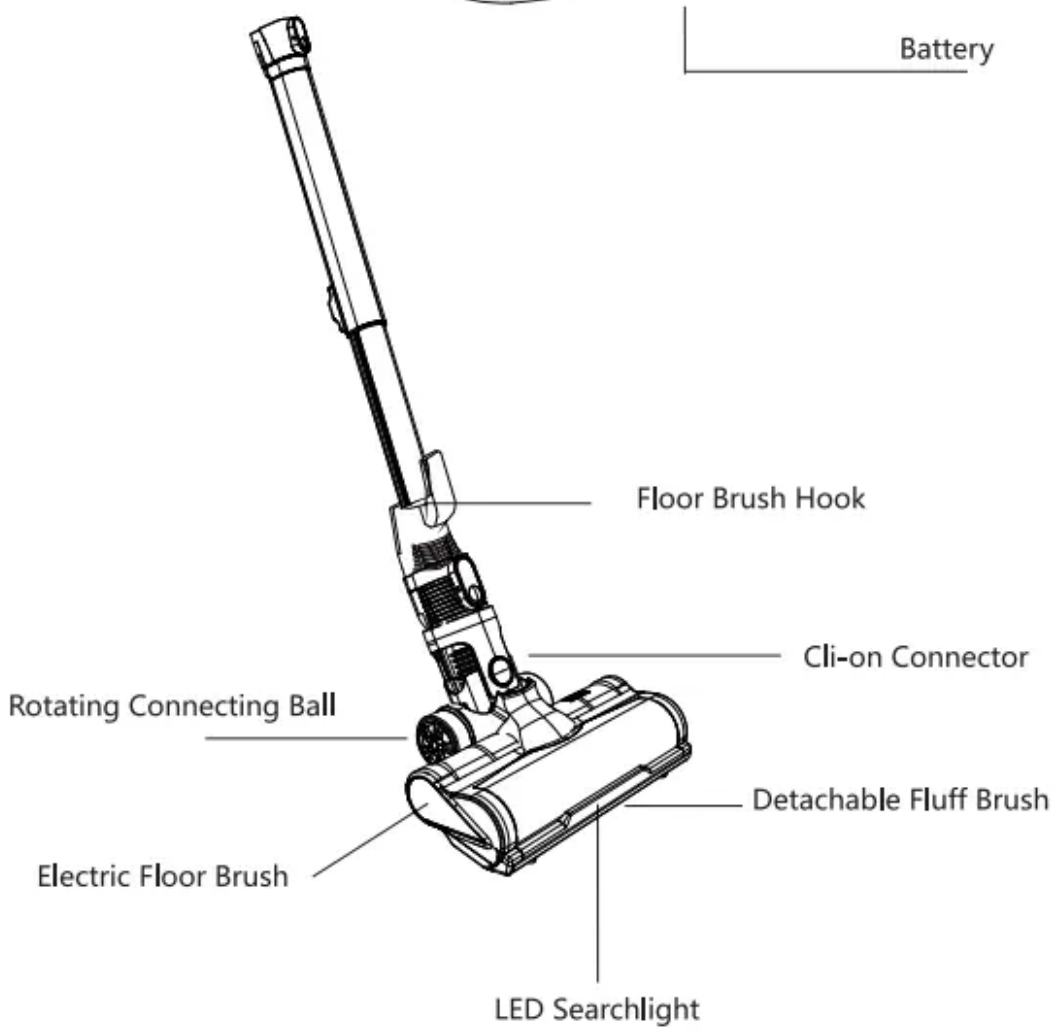
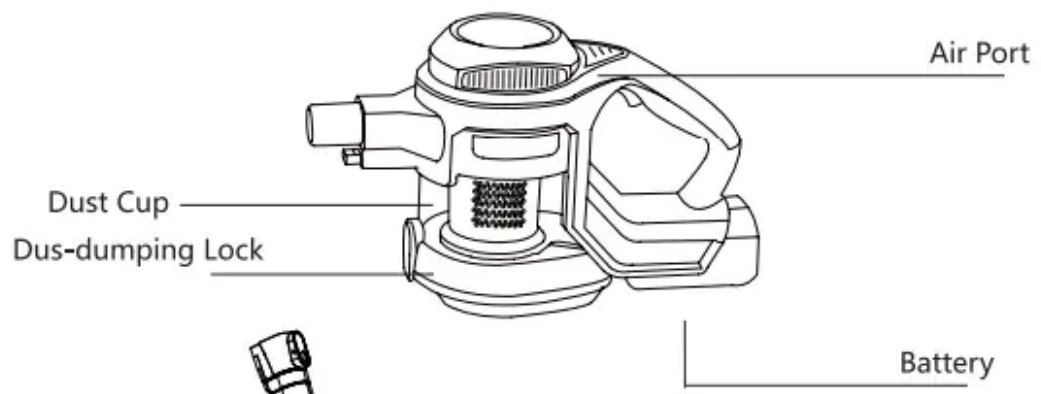

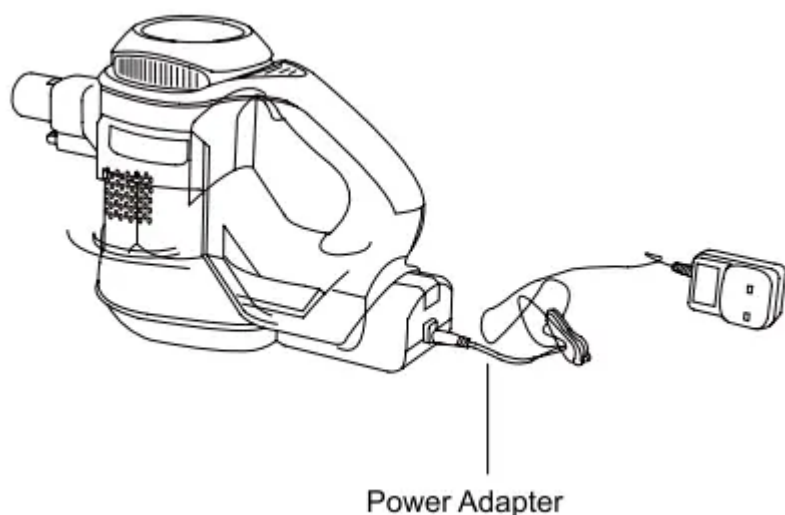

PRODUCT TECHNICAL PARAMETERS

Product Category : Vacuum Cleaner	Product Model: XL-618A
Dust Cup Capacity : 1.3L	Rated Voltage : DC 22.2V
Charging Time : 5.5hours	Rated Power: 100W
Battery Capacity: 2200mAh	Vacuum : 7KPa/10KPa
Length of Telescopic Rod: 18.9~27.2inches	
Power Adapter Input: 100-240V~50/60Hz	
Power Adapter Output: DC 26V 400mA	
Usage Time : 28min(low speed)/20min(high speed)	

SAFETY INSTRUCTIONS

1. When using electrical appliances, basic safety precautions should always be followed.
2. Check that the voltage indicated on the rating plate corresponds with that of the local network before connecting the appliance to the mains power supply.

3. Children aged from 8 years and people with reduced physical, sensory or mental capabilities or lack of experience and knowledge can use this appliance, only if they have been given supervision or instruction concerning use of the appliance in a safe way and understand the hazards involved.
4. Children should be supervised to ensure that they do not play with the appliance.
5. Unless they are older than 8 and supervised, children should not perform cleaning or user maintenance.
6. This appliance is not a toy.
7. This appliance contains no user serviceable parts. If the power supply cord, plug or any part of the appliance is malfunctioning or if it has been dropped or damaged, only a qualified electrician should carry out repairs.
8. Improper repairs may place the user at risk of harm.
9. Keep the appliance out of the reach of children.
10. Keep the appliance out of the reach of children when it is switched on or cooling down.
11. Keep the appliance away from heat or sharp edges that could cause damage.
12. Keep the appliance away from other heat emitting appliances.
13. Keep the appliance free from dust, lint, hair or anything that may reduce the airflow of the appliance.
14. Do not immerse the appliance in water or any other liquid.
15. Do not operate the appliance with wet hands.
16. Do not expose the appliance to rain.
17. Do not remove from the adaptor from the mains power supply by pulling the cord; switch off and remove the plug by hand.
18. Do not use the adaptor to recharge non-rechargeable batteries.
19. Do not use the appliance if it has been dropped or if there are visible signs of damage.
20. Do not use the appliance for anything other than its intended use.
21. Do not use any parts/accessories or adaptors other than those supplied with this appliance, as this may cause damage.
22. Do not use any damaged accessories or adaptors.
23. Do not use this appliance outdoors.
24. Do not store the appliance in direct sunlight or in high humidity conditions.
25. Do not use this appliance if any of the openings are blocked.
26. Do not use the appliance to pick up flammable liquid, matches, cigarette ends, hot ashes or any hot, burning or smoking objects.
27. Do not use this appliance to pick up hard, sharp objects such as glass or nails etc.

28. Do not use the appliance to pick up water or any other liquid, as this poses risk of an electric shock.
29. The hose should be checked regularly and must not be used if damaged.
30. Take care when equipping accessories with rotating parts as this could cause entrapment.
31. Switch off the appliance and disconnect it from the mains power supply before changing or fitting accessories.
32. Always ensure that the appliance has cooled fully after use before performing any cleaning or user maintenance.
33. Use of an extension cord with the appliance is not recommended.
34. Only use the appliance with the power supply unit provided.
35. This appliance should not be operated by means of an external timer or separate remote control system.
36. This appliance is intended for domestic use only. It should not be used for commercial purposes.

Caution: The extension tube contains electrical connections. Do not use to suck up water. Do not immerse in water for cleaning. The extension tube should be checked regularly and must not be used if damaged.

PRODUCT INTRODUCTION

Aluminum-alloy Tube Installation

1. Push the adjustable aluminum-alloy tube end into the suction port of the main engine in horizon-tal direction. Make sure there is no looseness; The hearing of "click" means successful installation.(as picture shows)

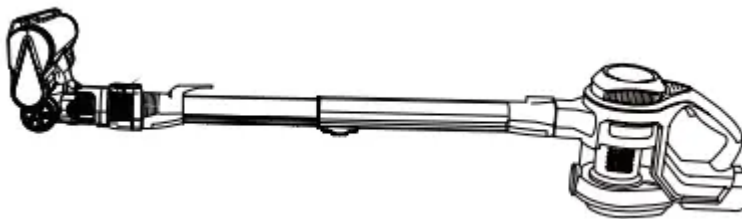

2. To get the aluminum alloy tube off. press the release button and pull the tube out. (as picture shows)



Electric Floor Brush Installation

1. Push the floor brush into the snap joint of the aluminum alloy tube. The sound of “click” means right and successful installation. (as picture shows)
2. To get the floor brush off, press the release button and pull the tube out. (as picture shows)

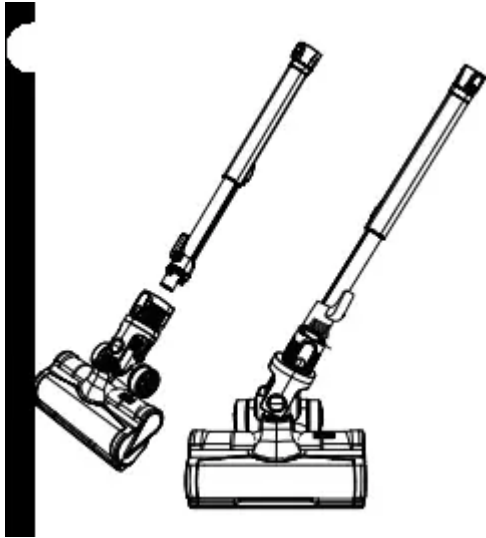

2-in-1 Dusting Brush Installation

It can be installed in two ways: dusting brush - vacuum / dusting brush - tube -vacuum. It's suitable for cleaning



Operating

1. Preparation

- Please make sure the power is sufficient before using. It's recommended to charge for 6 hours before its first use.

2. Operating

- Choose the right accessory for specified task. Adjustable two modes meet different needs. Press the on/off switch to make the vacuum work. Press again shifts it to the stronger mode. The third press to shut off the machine.

3. Dust cup and HEPA cleaning

- It's recommended to empty the cup after every use. The HEPA inside is washable and recyclable. Just wash the HEPA under the faucet and set it back when it's air dried.

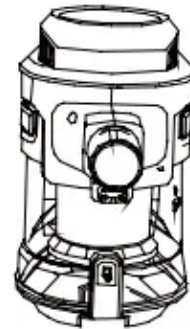
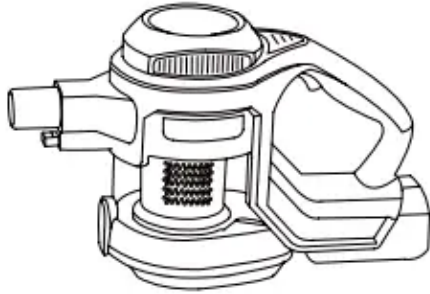

DAILY MAINTENANCE



Product Maintenance

It's suggested to do some maintenance daily to keep the machine works regularly and to prolong its service life.

1. Main Engine (Handheld part)

- Please stop the machine before cleaning
- Scrub with water or neutral detergent; please dry off the cleaning cloth before cleaning; Prevent the water from flowing into inner machine.

2. Dust Cup Cleaning

- Regular cleaning helps to ensure product performance. The sign  is emptying reminding.
- Please empty the dust cup promptly once the dust approaches or arrives . Just press the button to open the bottom cover of the dust cup.

3. HEPA Cleaning

- Regular cleaning helps to ensure product performance. Just take out the HEPA and its cover out from the dust cup and wash under the faucet. Please put it back when it's air

dried.

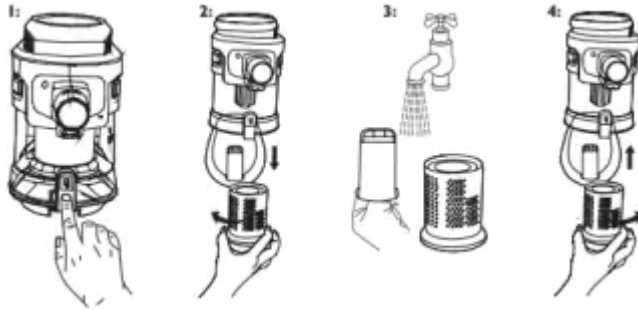

4. Detachable Fluff Brush Cleaning

- Find the buckle on the left side of the floor brush head and open it up. Take out the fluff brush and remove the cords and hairs on it with scissors or the gifting cleaning brush in the package.

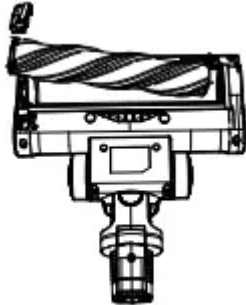

5. Electric Floor Brush Cleaning

It is recommended to clean once after every 4 to 5 times use of the floor brush.

- Turn off the power switch
- Take off the Electric Floor Brush.
- Take out the fluff brush.
- Unplug the cover of the fluff brush's head. clean up the dirt and hair on it.
- Put the fluff brush back into the floor brush.

Signal Hints

- The indicator shows the remaining battery once pressing the power-on switch.
- The indicating light flashes when the remaining power is lower than 5%. Please charge it on time to avoid battery damage.
- If the battery is charged equipped in the machine. the indicator displays the power.
- Do not operate the machine when it's charging.

Trouble Resolutions

Common Failure Analysis and Treatment

Symptom	Possible	Causes
Vacuum cleaner doesn't work	<ol style="list-style-type: none"> 1. Low battery 2. Product suction is blocked 	<ol style="list-style-type: none"> 1. Connect the power adapter to the main engine and charge 2. Take out the battery, charge with the charging seat 3. Clean up the suction inlet
Product suction is weaken	<ol style="list-style-type: none"> 1. Dust cup and the Filter component is dusty 2. The brush head was blocked with hair 	<ol style="list-style-type: none"> 1. Clean up the dust cup and filter material 2. Clean up the brush head and other accessories
Motor has strange sound when working	Main suction tube or aluminum tube are blocked	<ol style="list-style-type: none"> 1. Clean up the Blockage 2. If it still doesn't work, please contact our customer service team
Electric floor brush does not rotate	Brush searchlight is off Roller brush was blocked with hair	Clean up all hair on the brush and unplug the cover of the brush to remove the hair on the roller

The crossed out wheelie bin symbol on this item indicates that this appliance needs to be disposed of in an environmentally friendly way when it becomes of no further use or has worn out. Contact your local authority for details of where to take the item for recycling



Problem Self-Checking Q&A

Weak Suction	Stop working suddenly	Floor brush malfunction	Charging related
<p>"Check if the product is assembled correctly. (please assemble the product according to the instructions)"</p>	<p>"Thermostat protection triggered by motor overheating (allow the machine to cool for 30 minutes and then restart)"</p>	<p>"Check if the product is assembled correctly. (please assemble the product according to the requirements of the manual)"</p>	<p>"Check if the product is assembled correctly. Please follow the instructions to install the battery pack and the main engine of the machine. Ensure that the battery pin is fully integrated with the motor.)"</p>
<p>"Check for foreign matter blockage? (remove the foreign body from the connecting pipe or floor brush)"</p>	<p>"machine protection triggered by blocking (open the machine again after cleaning the foreign matter blocking the air inlet)"</p>	<p>"Check for foreign matter blockage? (remove hair, foreign matter, etc from both sides of the brush)"</p>	<p>"No charge? The adapter is out of order. Please bring video and text description to contact customer service.)"</p>
<p>"Is the HEPA too dirty? (take out the HEPA and put it back after cleaning. Please dry it thoroughly before reassembling it. It's recommended to replace the hepa every 2 months to keep good suction and cleaning</p>	<p>"Machine damaged (please bring video and text description to contact customer service)"</p>	<p>"Carpet wool too long? (when cleaning carpets, the long hairs tend to stick on the brush, causing damage to the brush.)"</p>	<p>"Can't use it on full charge? Check if the battery is assembled correctly? If you can't use it, please bring video and contact customer service with the problem.)"</p>

performance. Note: machine runs with wet HEPA will damage the product and reduce suction)"			
"Is the battery power enough? (suction maybe influenced by the battery power, if the suction decreased obviously, please recharge the battery)"	'Is the battery power enough? Please start it after recharge."	"The floor brush turns but the LED doesn't work? LED lights but floor brushes don't work? (please bring video and text description to contact customer service)"	"Hot when charged? (recharge after cooling. If there is no improvement, contact customer service.)"

Battery Safety

If the battery pack becomes exhausted, it should be removed from the product to avoid leakage.

In the event of the battery pack leaking, do not allow any liquid to come into contact with the skin or eyes.

If contact has been made, wash the affected area with copious amounts of water and seek medical advice.

Keep the battery pack out of the reach of children.

Secondary battery packs need to be charged before use, After extended periods of storage, it may be necessary to charge and discharge the batteries several times to obtain maximum performance.

Do not leave battery packs on charge for prolonged periods of time.

Do not use any charger other than that specifically provided for use with the product.

The supply terminals are not to be shoe-circuited.

Do not store above 60°C. Avoid storing in direct sunlight.

Do not use any battery packs that are not designed for use with the product.

Do not dispose of the battery pack in a fire.

Do not crush, puncture, dismantle or otherwise damage the battery pack.

Do not dismantle, open or shred battery packs.

Do not expose the battery pack to heat or fire as it may explode.

Do not subject the battery pack to mechanical shock.

Do not dispose of the exhausted battery pack in household waste.

To dispose of the exhausted battery pack, take it to a local recycling station, Contact the local government offices for further details,

This appliance is fitted with a 22.2 V 2200 mAh Li-ion rechargeable battery,

WARNING

Read all safety warnings and instructions. Failure to follow the warnings and instructions may result in electric shock, fire and/or serious injury.

1. Prevent unintentional starting. Ensure the switch is in the off-position before connecting to battery pack, picking up or carrying the appliance. Carrying the appliance with your finger on the switch or energizing appliance that have the switch on invites accidents.
2. Disconnect the battery pack from the appliance before making any adjustments, changing accessories, or storing appliance.
Such preventive safety measures reduce the risk of starting the appliance accidentally.
3. Recharge only with the charger specified by the manufacturer. A charger that is suitable for one type of battery pack may create a risk of fire when used with another battery pack.
4. Use appliances only with specifically designated battery packs. Use of any other battery packs may create a risk of injury and fire.
5. When battery pack is not in use, keep it away from other metal objects, like paper clips, coins, keys, nails, screws or other small metal objects, that can make a connection from one terminal to another. Shorting the battery terminals together may cause burns or a fire.
6. Under abusive conditions, liquid may be ejected from the battery avoid contact. If contact accidentally occurs, flush with water. If liquid contacts eyes, additionally seek medical help. Liquid ejected from the battery may cause irritation or burns.
7. Do not use a battery pack or appliance that is damaged or modified. Damaged or modified batteries may exhibit unpredictable behavior resulting in fire, explosion or risk of injury.
8. Do not expose a battery pack or appliance to fire or excessive temperature. Exposure to fire or temperature above 130° C may cause explosion. The temperature of 130 ° C can be replaced by the temperature of 265° F.

9. Follow all charging instructions and do not charge the battery pack or appliance outside of the temperature range specified in the instructions. Charging improperly or at temperatures outside of the specified range may damage the battery and increase the risk of fire.
10. Have servicing performed by a qualified repair person using only identical replacement parts. This will ensure that the safety of the product is maintained.
11. Do not modify or attempt to repair the appliance or the battery pack (as applicable) except as indicated in the instructions for use and care.

Warning

This content is compiled from multiple sources and is provided for reference purposes only. It may not be complete or fully applicable to all situations. If you are unable to resolve your issue, please contact the product manufacturer or an authorized service provider for official support.