

## Operation Component Locations

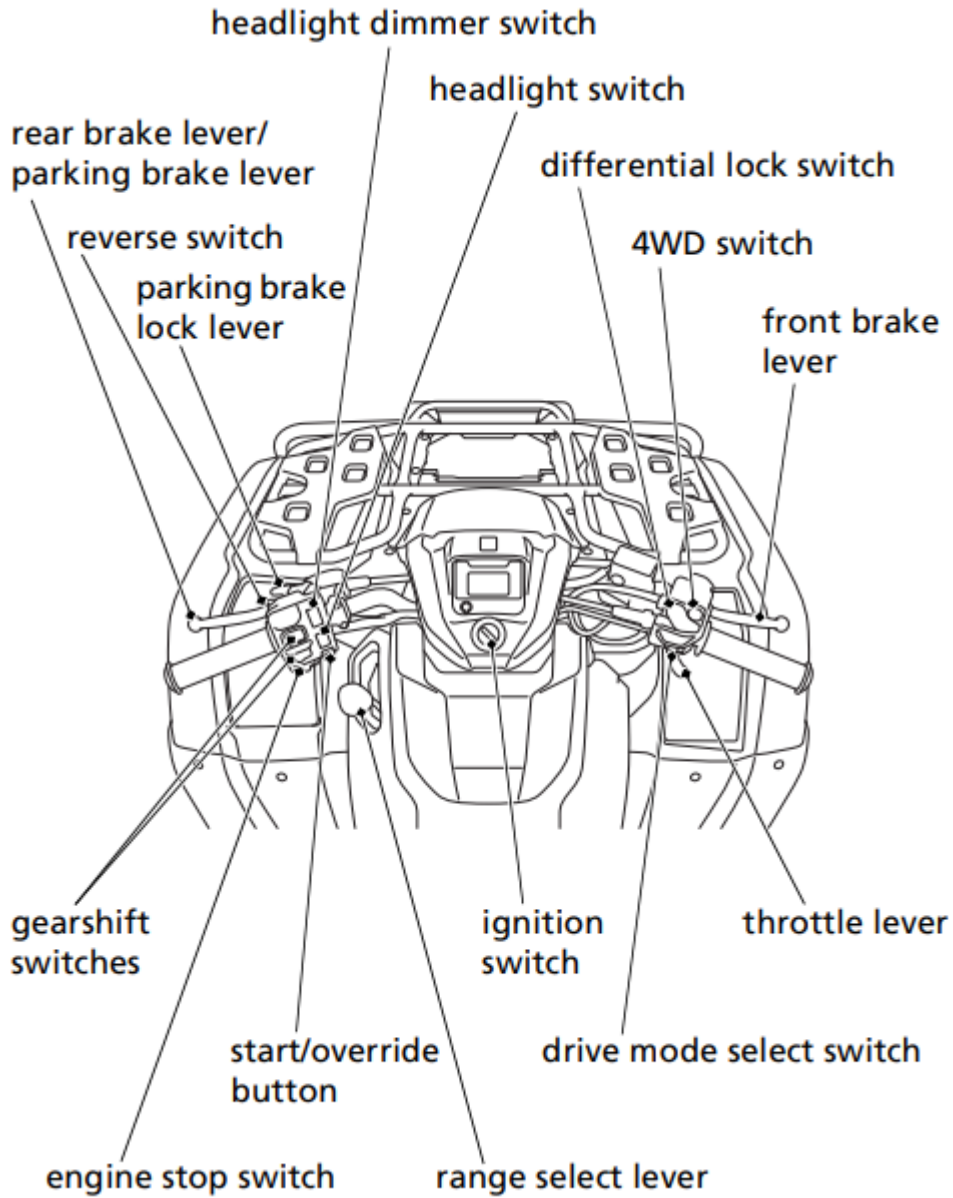

rear cargo rack

front cargo rack

front utility box

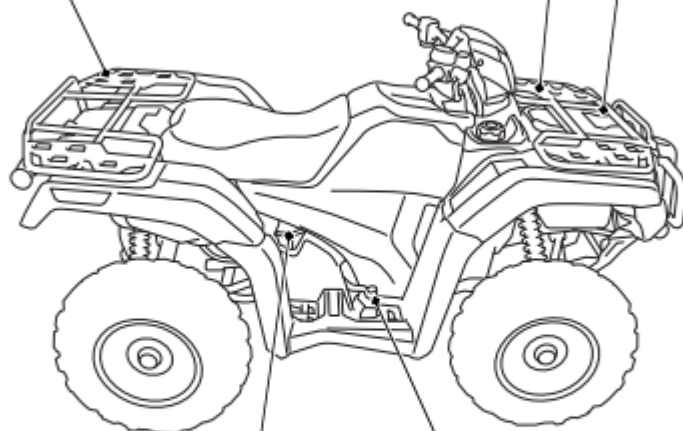

recoil starter  
(Canada only)

rear brake pedal



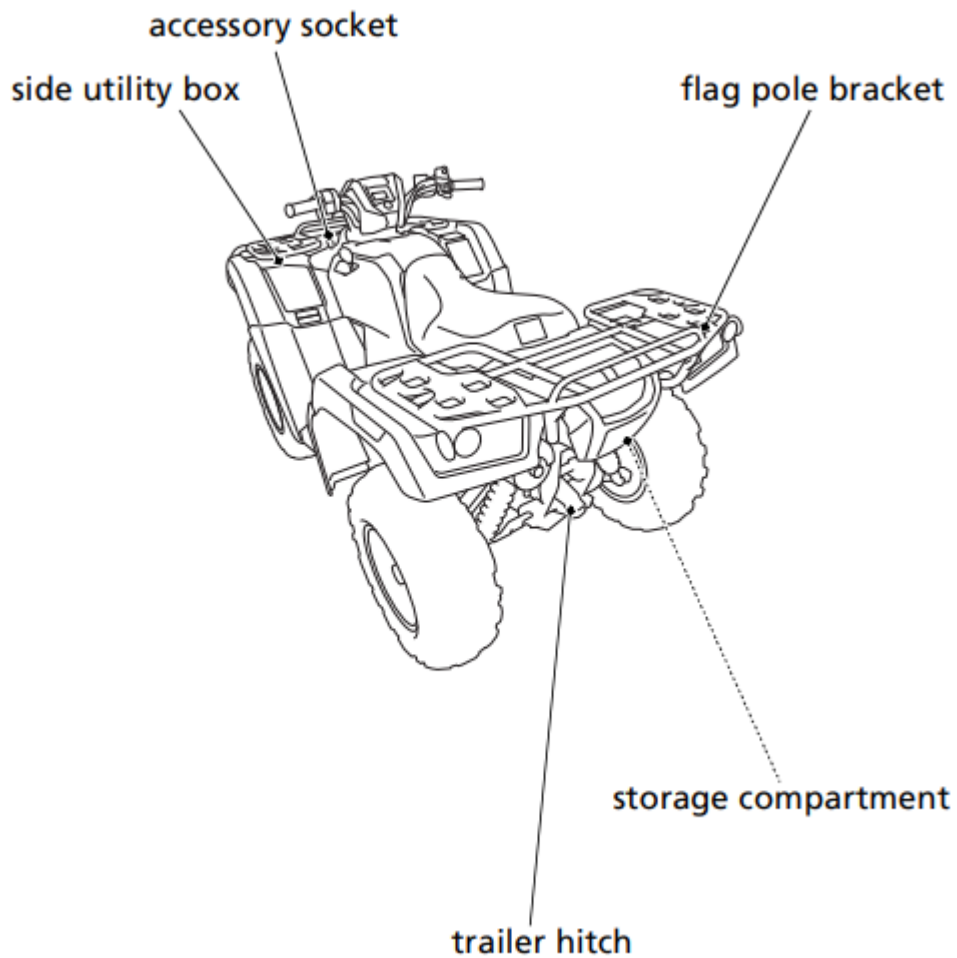

## Indicators & Displays

The indicators and displays on your ATV keep you informed, alert you to possible problems, and make your riding safer and more enjoyable. Refer to the indicators frequently. Their functions are described on the following pages.

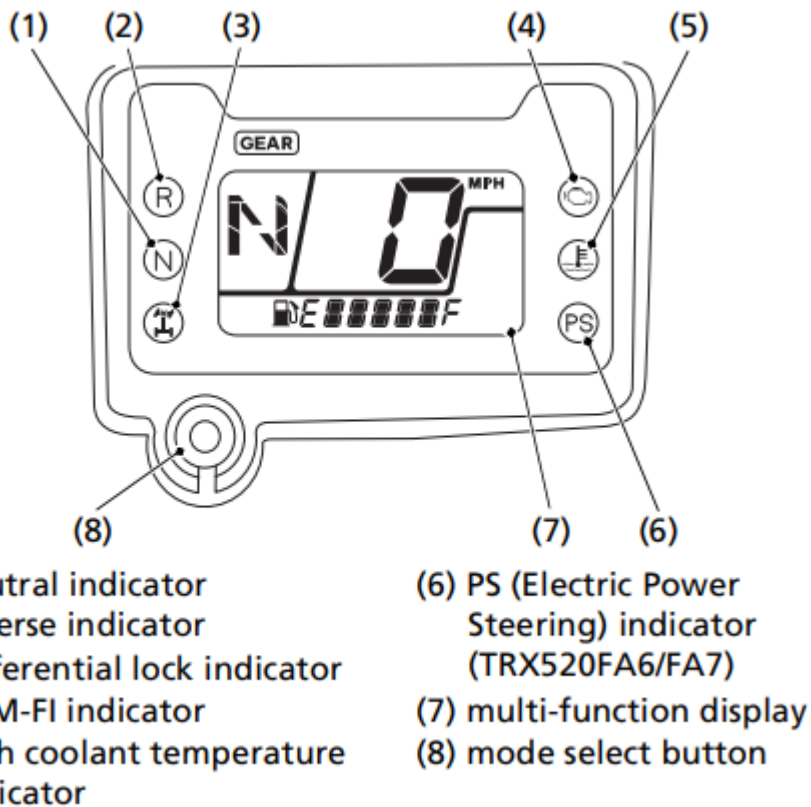

### Lamp Check

Initial lamp check:

The indicators come on for a few seconds and then go off when you turn the ignition switch to ON (q).

TRX520FA6/FA7:

The PS (Electric Power Steering) indicator comes back on and remains on until the engine is started after initial lamp check.

The high coolant temperature indicator and PGM-FI indicator comes back on for a few seconds and then go off after initial lamp check.

These indicators are identified in the table on page 17 with the words: Lamp Check.

When applicable, the reverse or neutral indicators come back on and remain on until you shift out of reverse or neutral after initial lamp check.

When applicable, the differential lock indicator comes back on and remains on until you shift out of the front differential lock mode after initial lamp check.

If one of these indicators does not come on when it should, have your dealer check for problems.

### Display Check



When the ignition switch is turned on, the multi-function display (1) will temporarily show all the modes and digital segments and initial message. So you can make sure the liquid crystal display is functioning properly.

The displays are identified in the table on page 18 with the words: Display Check.

If any part of these displays does not come on when it should, have your dealer check for problems.

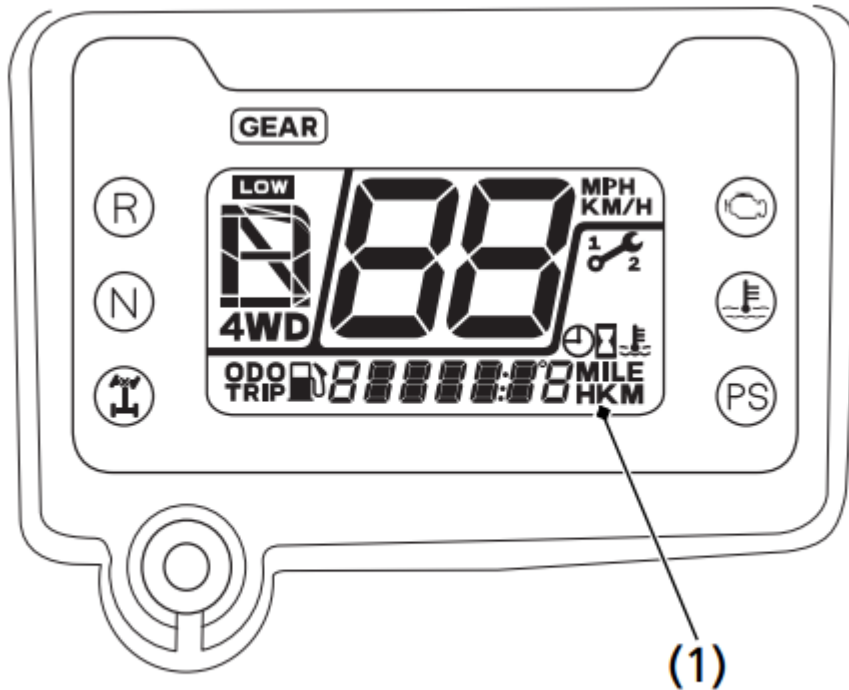

**(1) multi-function display**

### **Meter Input Signal Failure**

If the neutral indicator, reverse indicator, differential lock indicator, PGM-FI indicator, high coolant temperature indicator stay on and the gear position indicator “-” and coolant temperature gauge “C - - - - - H” blink, have your dealer check for problems.

1	Neutral indicator	Lights when the transmission is in neutral. <i>Lamp Check.</i>
2	Reverse indicator	Lights when the transmission is in reverse. <i>Lamp Check.</i>
3	Differential lock indicator	Lights when the front differential lock mode is engaged. Should also light for a few seconds and go off when the ignition switch is turned on, and then come back on and remain on until the differential lock switch or the ignition switch is turned off. If the indicator blinks with the 4WD indicator, there is any abnormality in the front final gear system. See page 40. <i>Lamp Check.</i>
4	PGM-FI indicator	Lights when there is any abnormality in the PGM-FI (Programmed Fuel Injection) system. Should also light for a few seconds and then go off when the ignition switch is turned on. If the indicator comes on at any other time, reduce speed and take your vehicle to your dealer as soon as possible. <i>Lamp Check.</i>
5	High coolant temperature indicator	Lights when coolant temperature is high enough to adversely affect the service life of the engine.  If the high coolant temperature indicator comes on while you are riding, immediately bring the vehicle to a stop, turn the engine off and let it cool. See page 230. <i>Lamp Check.</i>

6	PS (Electric Power Steering) indicator (TRX520FA6/FA7)	Lights when there is an abnormality in the EPS (Electric Power Steering) system. See page 59. <i>Lamp Check.</i>
7	Multi-function display	The display includes the following functions. <i>Display Check.</i>
	4WD indicator	Shows when the 4WD drive mode is engaged. If the indicator blinks with the differential lock indicator when there is any abnormality in the front final gear system. See page 22.
	Gear position indicator	Shows the gear position (page 24).
	LOW indicator	Shows when low (L) range is engaged (page 23).
	Maintenance minder indicator	Shows when specified maintenance interval is reached (page 33).
	Speedometer	Shows riding speed.
	Fuel gauge	Shows approximate fuel supply available (page 25).
	Digital clock	Shows the time (hour and minutes) (page 27).
	Odometer	Shows accumulated mileage (page 28).
	Tripmeter	Shows mileage per trip (page 28).
	Coolant temperature gauge	Shows approximate coolant temperature (page 29).
	Hour meter	Shows hours and tenths of hours of engine operation (page 31).

	Maintenance tripmeter	Inform when the mileage or operating hours on your ATV approaches and passes the interval specified on the maintenance schedule .
	Maintenance hour meter	
8	Mode select button	Selects display in the lower parts of multi-function display. Adjusts the digital clock (page 27). Changes the speed and mileage units (page 22). Resets the tripmeter to zero (0) (page 28). This button also used to reset the maintenance tripmeter and maintenance hour meter (page 32).

## Multi-function Display

The multi-function display (1) includes the following functions:

- 4WD indicator
- Gear position indicator
- LOW indicator
- Speedometer
- Maintenance minder indicator
- Fuel gauge
- Digital clock
- Odometer
- Tripmeter
- Coolant temperature gauge
- Hour meter
- Maintenance tripmeter
- Maintenance hour meter

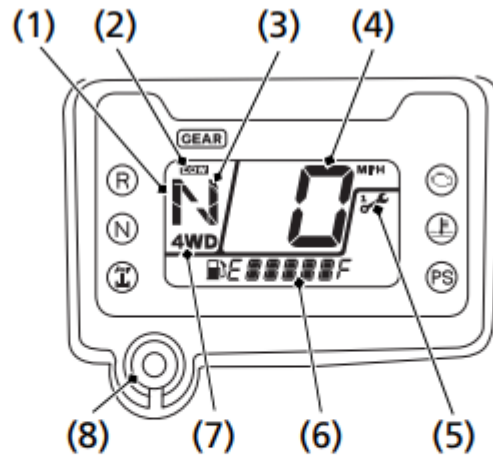

- (1) multi-function display
- (2) LOW indicator
- (3) gear position indicator
- (4) speedometer
- (5) maintenance minder indicator
- (6) lower part of the multi-function display
- (7) 4WD indicator
- (8) mode select button

The lower part of the multi-function display (6) shows the fuel gauge, digital clock, odometer, tripmeter, coolant temperature gauge, hour meter, maintenance tripmeter or maintenance hour meter. To change the lower part of the multi-function display, push the mode select button (8).

Each time you press the mode select button, mode will change as shown in the illustration.

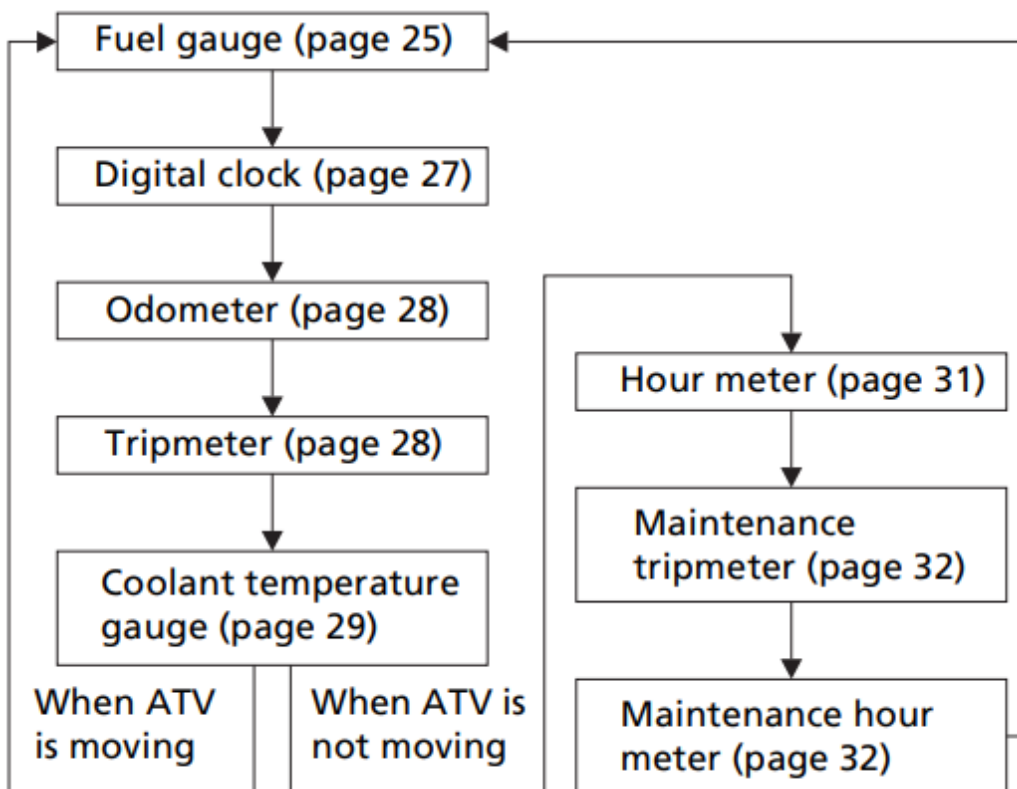

If there is a fuel warning with your ATV, the display will automatically change to the fuel gauge. If you try to change the display back to ordinary display, it will automatically return to the fuel gauge.

If there is a coolant temperature warning with your ATV, the display will automatically change to the coolant temperature gauge. If you try to change the display back to ordinary display, it will automatically return to the coolant temperature gauge.

### Speed and Mileage Unit Changing

The speedometer, odometer, tripmeter and maintenance tripmeter show in either “MPH” and “MILE” or “KM/H” and “KM”. To change the speed and mileage units, press and hold the mode select button (1) for more than 5 seconds in odometer mode (page 28) with the ATV stopped.

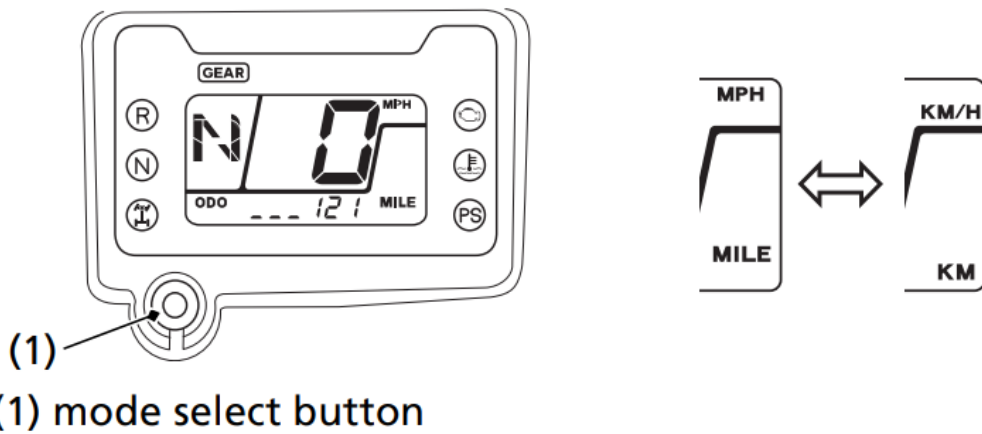

(1) mode select button

### 4WD Indicator

The 4WD indicator (1) shows when the 4WD mode engages

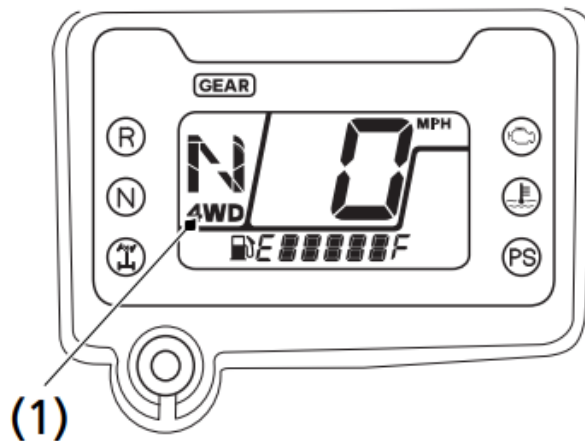

(1) 4WD indicator

### LOW Indicator

The LOW indicator (1) will be displayed when low (L) range is engaged with the ignition switch in the ON (q) position

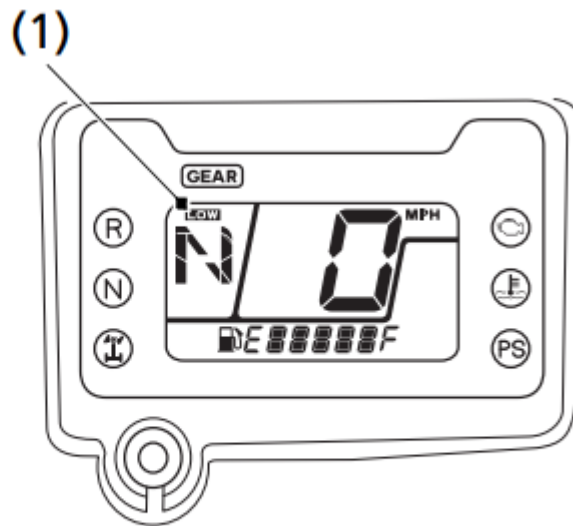

## (1) LOW indicator

### Gear Position Indicator

The gear position indicator (1) shows the gear position when the ignition switch is in the ON (q) position.

AUTO (automatic shift mode)

The indicator displays N for neutral, R for reverse, and D for drive.

ESP (manual shift mode)

The indicator displays N for neutral, R for reverse, and 1 – 5 for the five forward gears.

“–” will be displayed on the gear position indicator when the transmission is not shifted into gear properly. Before riding, check that the gear position is properly displayed on the gear position indicator.

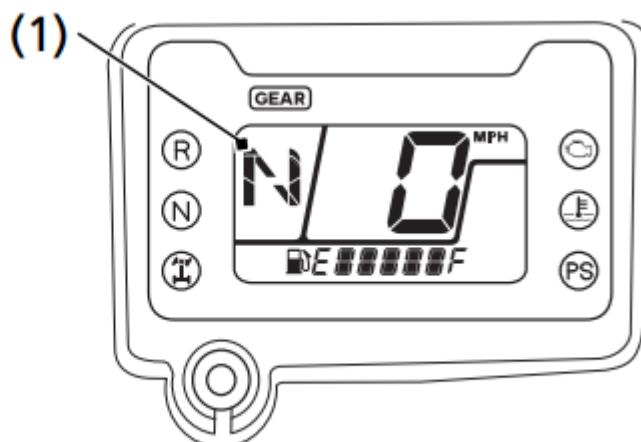

## (1) gear position indicator

If the gear position indicator shows “-” or blinks, turn the ignition switch to the OFF (w) position, and then turn it back to the ON (q) position again. If the gear position indicator still shows “-”, check that the range select lever is securely in a gear, rock the vehicle back and forth. Make sure the gear position is properly displayed in the gear position indicator, if the gear position indicator still shows “\_” or blinks, see your dealer.

## Fuel Gauge

The fuel gauge (1) shows the approximate fuel supply available with the fuel mark (2). The fuel tank capacity is: 3.88 US gal (14.7 ℓ)

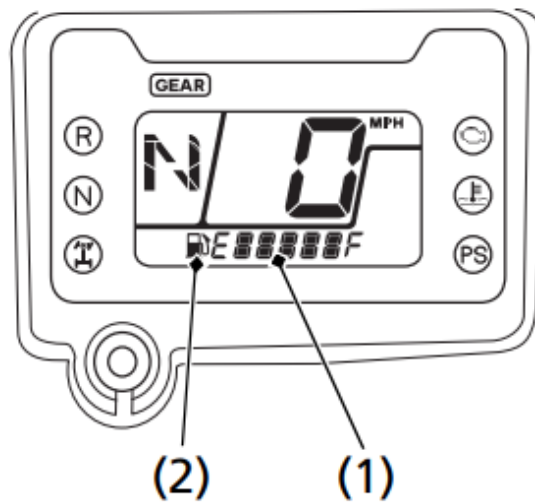

(1) fuel gauge

(2) fuel mark

Regardless of what mode the display is in, when the fuel level reaches only 1st segment (3), the display will automatically switch to the fuel gauge display. You should refuel as soon as possible. The amount of fuel remaining when the fuel gauge reaches the 1st segment is approximately: 1.82 US gal (6.9 ℓ)

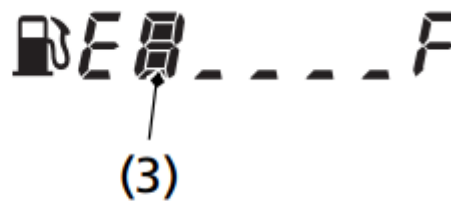

(3) 1st segment



When the fuel gauge show "E \_ \_ \_ \_ \_ F" (4) and "LO FUEL" (5) blink 3 times alternately and fuel mark blinks, you should refuel as soon as possible.

The amount of fuel reserve is approximately: 1.29 US gal (4.9 l)

Fuel gauge failure:

If the fuel gauge E \_ \_ \_ \_ \_ F (6) is blinking, the fuel gauge function has failed. See your dealer.

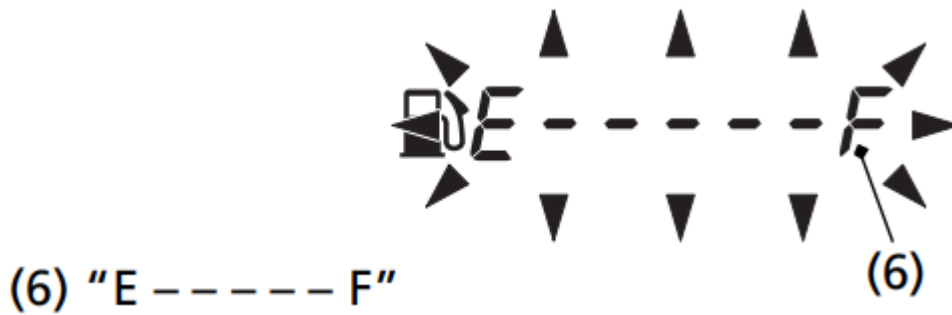

### Digital Clock

The digital clock (1) shows time with the clock mark (2) when the ignition switch is ON (q).

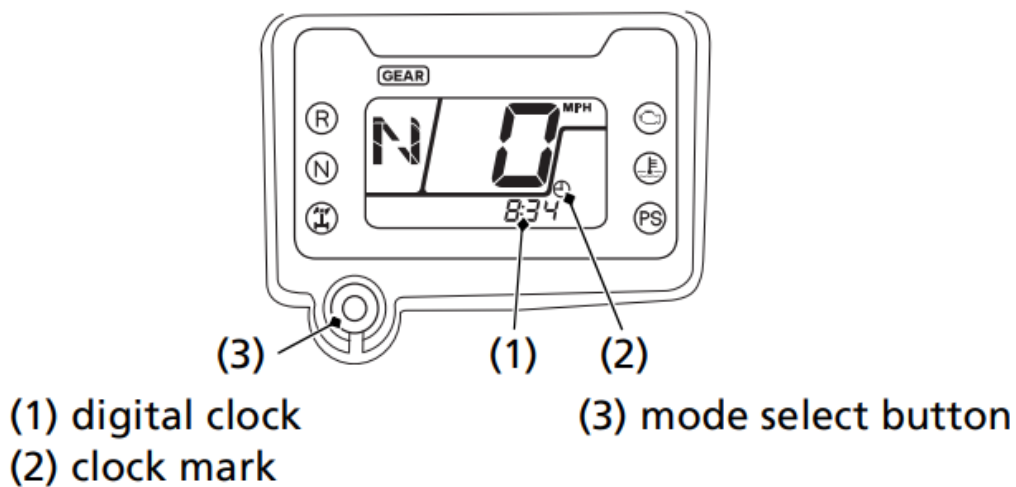

To adjust the time, proceed as follows:



1. Turn the ignition switch ON (q) and select the digital clock mode.
2. Press and hold the mode select button (3) until the display start blinking.
3. To advance the display 1 minute at a time, press and release the mode select button for 0.5 seconds. Press and hold the mode select button the display will begin advancing fast. Press and hold the button for:
  - 0.5 – 5.5 seconds: advance one minute at a time.
  - 5.5 – 10.5 seconds: advance five minutes at a time.
  - 10.5 seconds or more: advance ten minutes at a time.
4. Release the mode select button when the display reaches the desired time.
5. To end the adjustment, press and release the mode select button for less than 0.5 seconds or turn the ignition switch to OFF (w).

After the battery is reconnected (page 197), check the clock. Readjust the clock if necessary.

## Odometer

The odometer (1) registers total distance traveled in mileage while the ignition switch is ON (q) with the “ODO” mark (2). The odometer locks at 999,999 when the read-out exceeds 999,999.

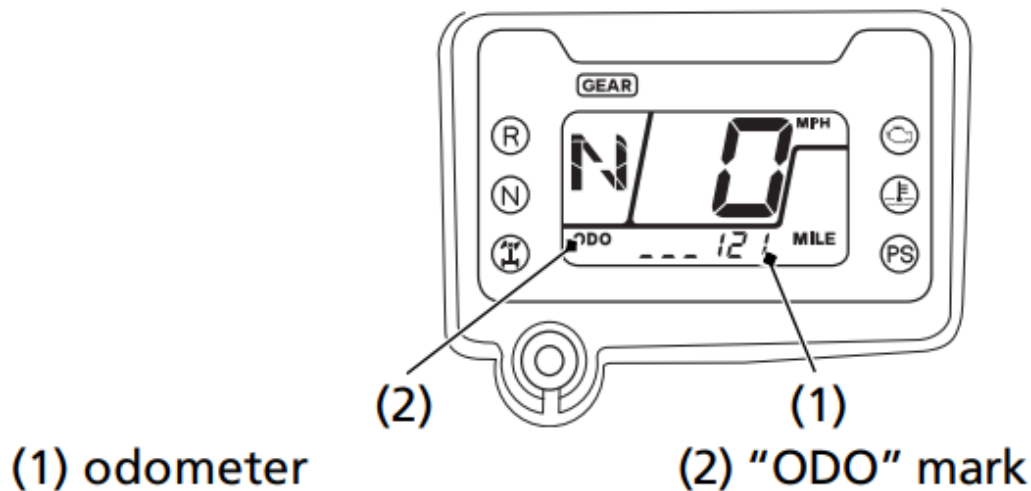

## Tripmeter

The tripmeter (1) shows mileage per trip since you last reset the tripmeter while the ignition switch is ON (q) with the “TRIP” mark (2). The tripmeter returns to 0.0 when the read-out exceeds 999.9. To reset the tripmeter to zero, press the mode select button (3) and hold it in for at least 2 seconds in the tripmeter mode.

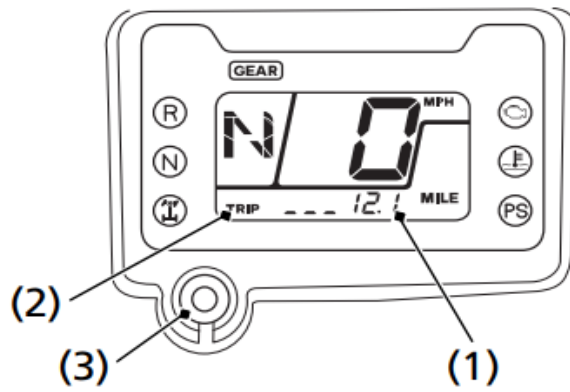

- (1) tripmeter
- (2) "TRIP" mark
- (3) mode select button

### Coolant Temperature Gauge

The coolant temperature gauge (1) shows coolant temperature with the coolant temperature mark (2) while the ignition switch is ON (q).

The normal operating temperature range is within the section between the 1st segment (3) and 4th segment (4).

When coolant temperature is low, the coolant temperature gauge will display "Lo" (5).

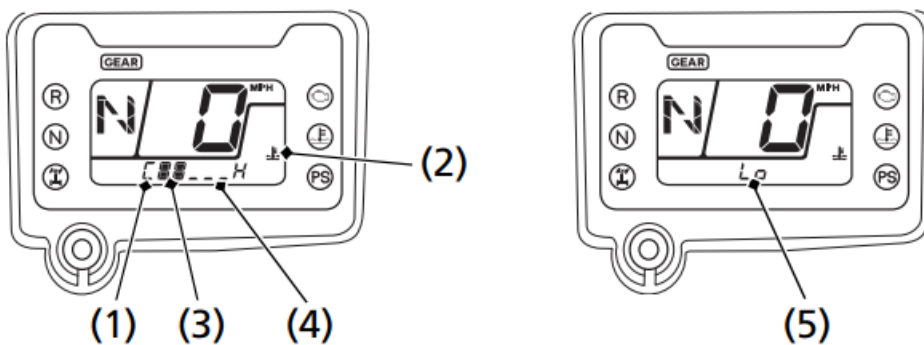

- (1) coolant temperature gauge
- (2) coolant temperature mark
- (3) 1st segment
- (4) 4th segment
- (5) "Lo"

When the coolant is over specified temperature, the 5th segment (6) appears and the high coolant temperature indicator (7) lights. If this occurs, stop the engine and check the reserve tank coolant level. Read pages 230 – 231 and do not ride the ATV until the problem has been corrected.

**NOTICE** Continuing to ride with an overheated engine can cause serious engine damage.



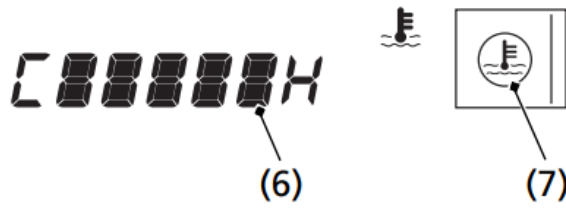

(6) 5th segment      (7) high coolant temperature indicator

If the "C - - - - - H" (8) blinks, the meter input signal fails. See your dealer.



(8) "C - - - - - H"

### Hour meter

The hour meter (1) shows accumulated hours while the ignition switch is ON (q) with the hour meter mark (2). The hour meter provides accurate service period information for initial and regular maintenance. The hour meter locks at 99,999.9 when the read-out exceeds 99,999.9.

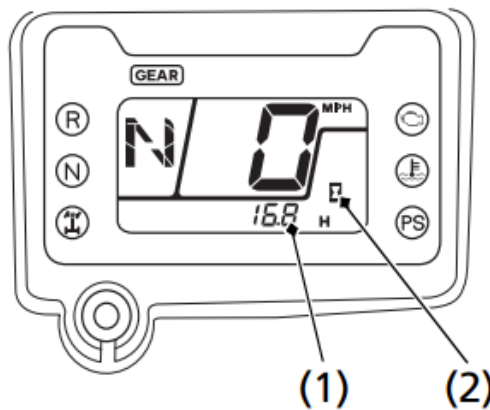

(1) hour meter

(2) hour meter mark



## Maintenance Tripmeter/Maintenance Hour meter

The maintenance tripmeter (1) shows mileage to maintenance while the ignition switch is ON (q) with the maintenance minder indicator (2).

The maintenance hour meter (3) shows remaining time to maintenance while the ignition switch is ON (q) with the maintenance minder indicator.

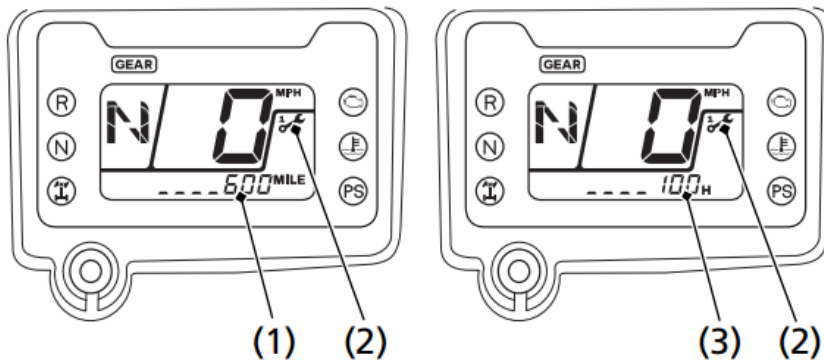



(1) maintenance tripmeter  
(2) maintenance minder indicator

(3) maintenance hour meter

The maintenance tripmeter decreases from 600 miles (1,000 km) after reset. The maintenance hour meter decreases from 100 hour after reset.

Initial setting of the maintenance tripmeter is 100 miles (150 km). Initial setting of the maintenance hour meter is 20 hour.

Maintenance Minder Indicators:

	<p><b>Initial Maintenance</b> Appears at 100 miles (150 km) or 20 operating hours, whichever comes first.</p>
	<p><b>Regular Maintenance Interval 1</b> Appears 600 miles (1,000 km) or 100 operating hours after the Initial Maintenance or Regular Maintenance Interval 2 is performed and maintenance minder is reset, whichever comes first in the maintenance schedule.</p>
	<p><b>Regular Maintenance Interval 2</b> Appears 600 miles (1,000 km) or 100 operating hours after Regular Maintenance Interval 1 is performed and maintenance minder is reset, whichever comes first in the maintenance schedule.</p>

When the maintenance tripmeter or maintenance hour meter amounts to 0, the display of the maintenance minder indicator changes. When the maintenance tripmeter or maintenance hour

meter are selected, the maintenance minder indicator and lower part of the multi-function display (4) start blinking. When other mode is selected, the maintenance minder indicator appears in the display.

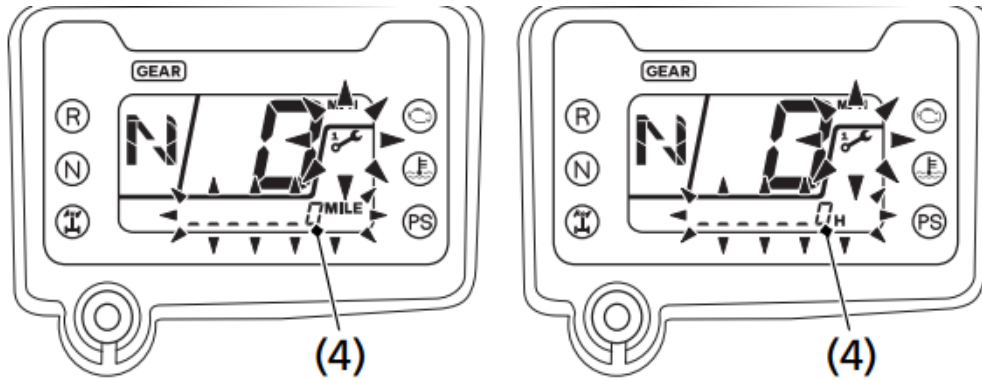

### (4) lower part of the multi-function display

Reset the maintenance tripmeter/maintenance hour meter after maintenances.

To reset the maintenance tripmeter/maintenance hour meter, proceed as follows:

Press and hold the mode select button (5) and turn the ignition switch (6) to ON (q). The maintenance minder indicator will appear, then it will blink twice, and the multi-function display will temporarily show all the modes and digital segments. The indicator message will disappear.

Reset operation will be cancelled, if the mode select button is released before the indicator blinks twice.

If the maintenance is done before the setting interval, be sure to reset the meters after the maintenance.

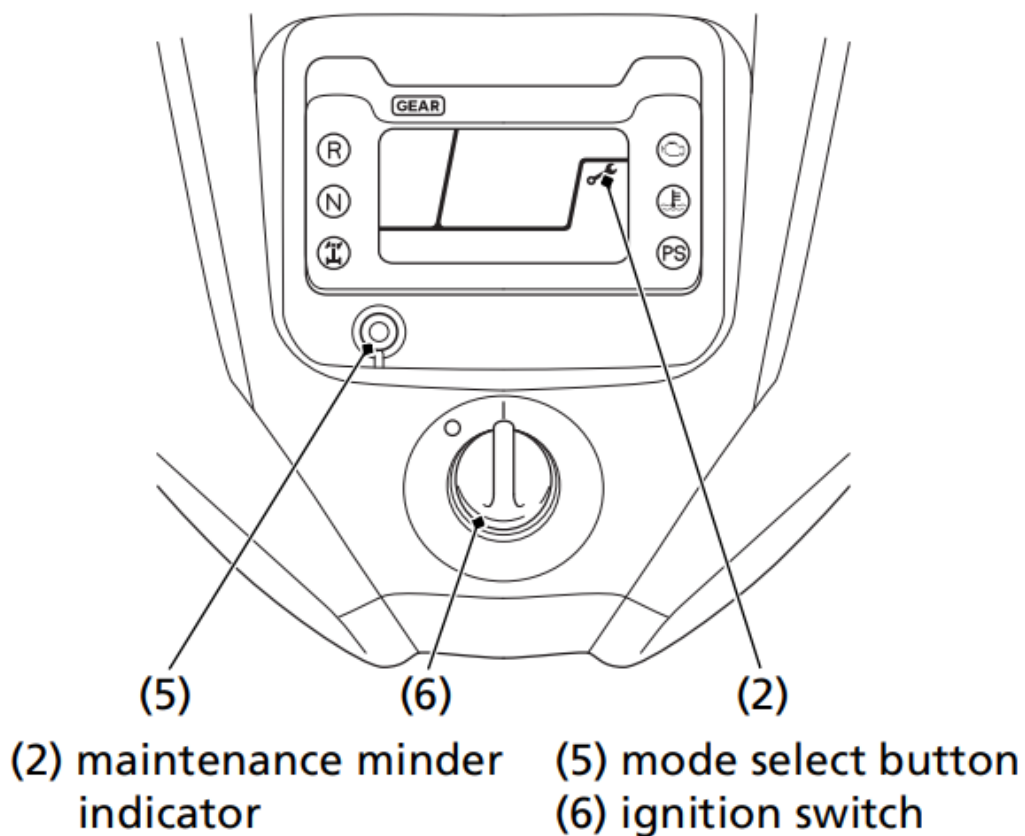

### Ignition Switch

The ignition switch (1) is used for starting and stopping the engine (page 84). Insert the key and turn it to the right for the ON ( I ) position.

The ignition switch is also used to reset the maintenance tripmeter and the maintenance hour meter (page 34).

Key Position	Function
ON ( I )	Electrical circuits on.
OFF ( O )	No electrical circuits function.

### CENTER OF HANDLEBAR

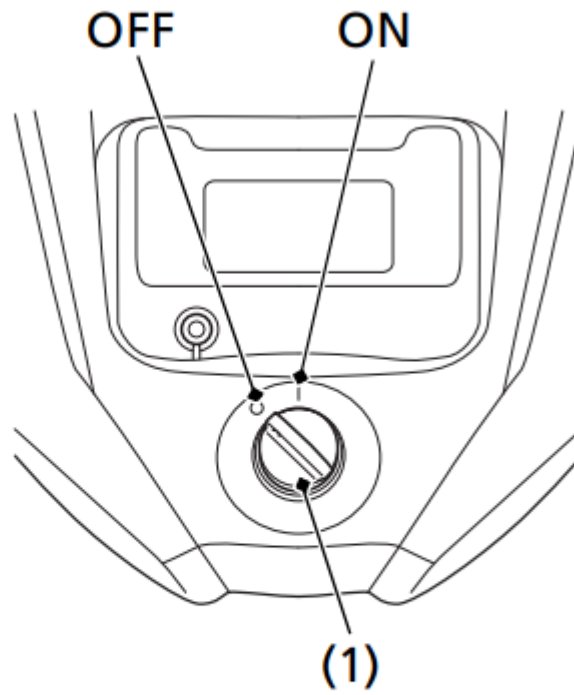

**(1) ignition switch**

**I ON**  
**O OFF**

### **Range Select Lever**

The range select lever (1) has two positions: Drive (D), Low (L). See Shifting Gears,

**LEFT SIDE OF FUEL TANK**

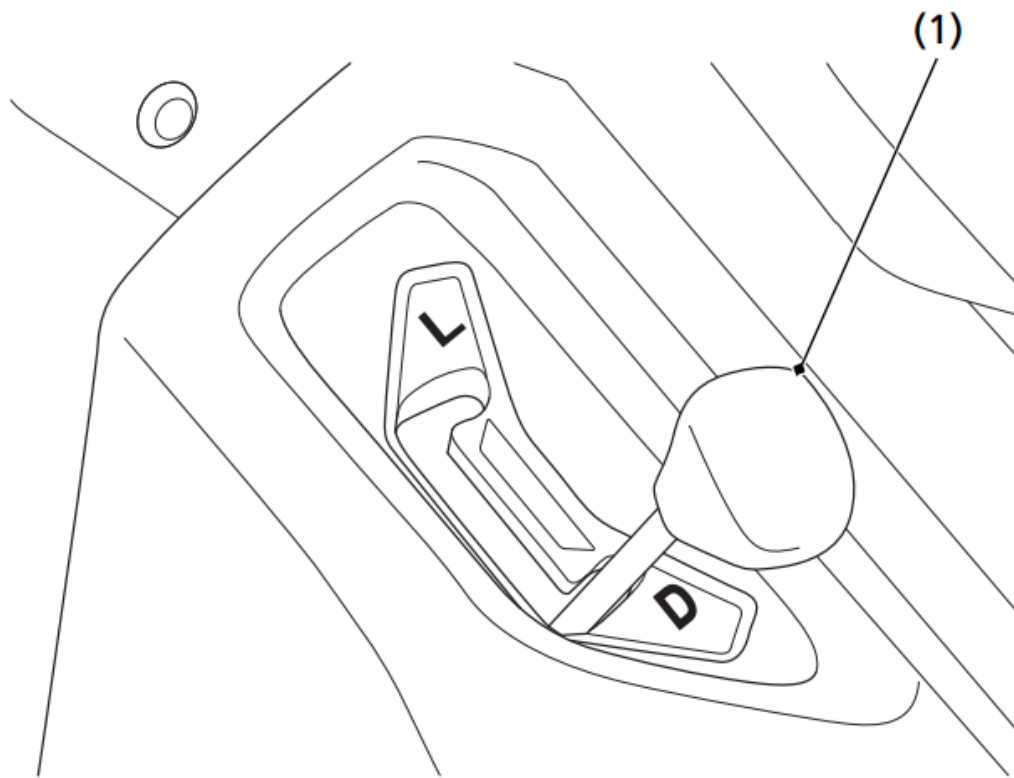

(1) range select lever

## Starting & Stopping the Engine

Always follow the proper starting procedure described below.

For your safety, avoid starting or operating the engine in an enclosed area such as a garage. Your ATV's exhaust contains poisonous carbon monoxide gas which can collect rapidly in an enclosed area and cause illness or death.

If you turn the ignition switch to the OFF (O) position while in reverse, the transmission will automatically return to neutral (N) when the ignition switch is turned to the ON (I) position. The starter motor will operate when the transmission is in neutral or the front brake lever is pulled in.

## Preparation

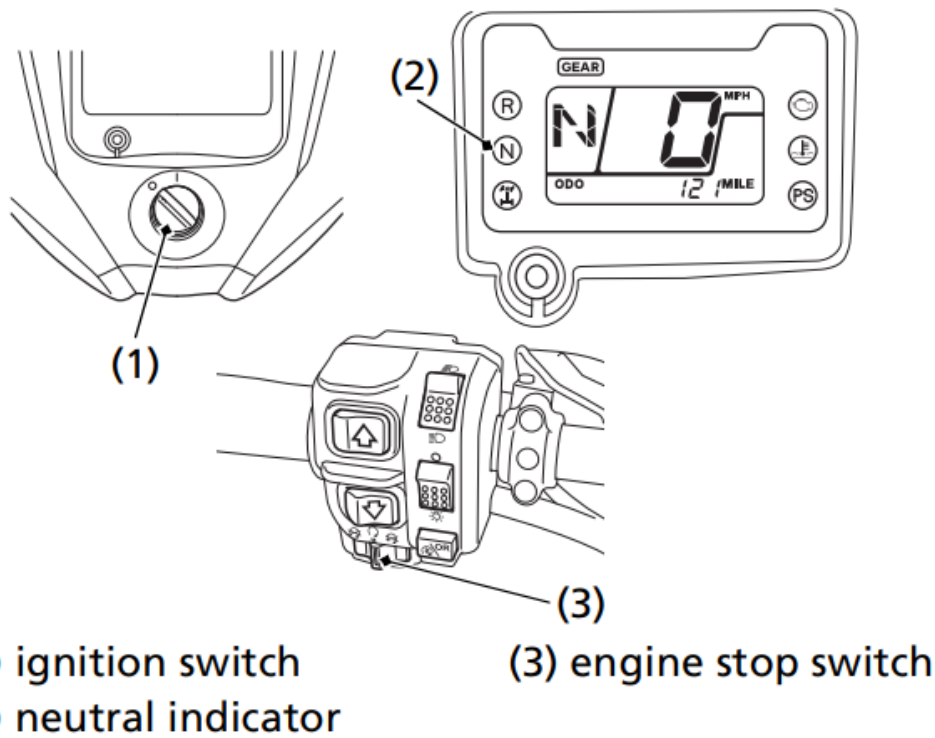

1. Before starting, make sure the vehicle is on a level surface and lock the parking brake

2. Turn the ignition switch (1) to ON (I).

Confirm the following:

- The transmission is in neutral, and the neutral indicator (2) is ON and the gear position indicator shows "N".
- The engine stop switch (3) is set to RUN (⊞)

## Starting Procedure

This ATV is fuel-injected with an automatic choke.

Follow the procedure indicated below.

### Any Air Temperature

- With the throttle completely closed, press the start/override button.

The engine will not start if the throttle is fully open (because the electronic control module cuts off the fuel supply).

Snapping the throttle or fast idling for more than 5 minutes may cause exhaust pipe and muffler discolorations.

## Flooded Engine

If the engine fails to start after repeated attempts, it may be flooded with excess fuel. To clear a flooded engine:

1. Leave the engine stop switch set to RUN (⊞).
2. Open the throttle fully.
3. (USA)

Press the start/override button for 5 seconds.

(Canada)

Press the start/override button for 5 seconds (or operate the recoil starter several times).

4. Follow the normal starting procedure.
5. If the engine starts, then open the throttle slightly if idling is unstable. If the engine does not start, wait 10 seconds, then follow steps 1 – 4 again.

If the engine still won't start, refer to If Your Engine Quits or Won't Start,

## Bank Angle Sensor Ignition Cut-off System

Your vehicle's banking (lean angle) sensor system is designed to automatically stop the engine if the vehicle is overturned.

Before restarting the engine, you must turn the ignition switch to the OFF (⊙) position and then back to ON (I). The engine will not restart until you perform this procedure.

## Stalled Engine

You can restart the engine while the vehicle is stopped by squeezing the front brake lever and pressing the start/override button.

Do not press the throttle lever while starting in gear. The engine will not start if the throttle is fully open (because the electronic control module cuts off the fuel supply).

Once you have started the engine, release the front brake lever, then apply throttle gradually.

## How to Stop the Engine

### Normal Engine Stop

To stop the engine, make sure the transmission is in neutral by checking that the neutral indicator light is on, then turn the ignition switch to OFF (⊙)

The engine stop switch should normally remain in the RUN (⊞) position even when the engine is OFF.

If your ATV is stopped with the engine stop switch OFF (⊗) and the ignition switch ON (I) the battery will discharge.

### Emergency Engine Stop

To stop the engine in an emergency, use the engine stop switch. To operate, slide the switch to either OFF (⊗) position.

### Using the Recoil Starter (Canada only)

The recoil starter is used to start the engine when the battery is low.

To operate the recoil starter:

1. Turn the ignition switch to ON and engine stop switch to RUN.
2. Check that the transmission is in neutral.
3. Grasp the starter grip (1) firmly, then pull it out slowly approximately 4 in (100 mm).
4. Pull the grip up briskly and fully.
5. After the engine starts, allow the starter grip to return slowly.

Pull the recoil starter grip straight out so that the cord does not touch the side cover. Repeated contact with the side cover can damage the starter cord.

If the starter grip does not return smoothly (because of dirt in the assembly), see your dealer.

## RIGHT SIDE

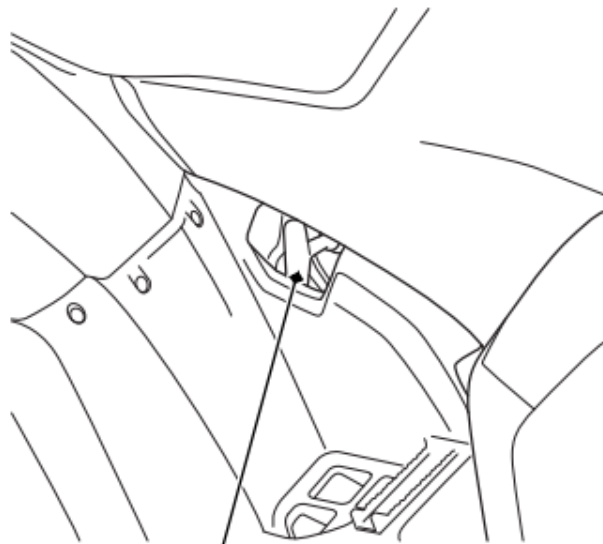

(1)

(1) starter grip

## **Is Your ATV Ready to Ride?**

Before each ride, it's important to inspect your ATV and make sure any problem you find is corrected. A pre-ride inspection is a must, not only for safety, but because having a breakdown, or even a flat tire, can be a major inconvenience.

If your ATV has overturned or been involved in a collision, do not ride the vehicle until it has been inspected by your dealer. There may be damage or other problems you cannot see.

### **Pre-ride Inspection**

Check the following items before you get on the ATV

Engine Oil	Check the level and add oil if needed (page 142). Check for leaks.
Radiator Coolant	Check the coolant level and add coolant if needed (page 154). Check for leaks.
Fuel	Check the level and add fuel (page 137) if needed. Also make sure the fuel fill cap is securely fastened. Check for leaks.
Tires	Use a gauge to check the air pressure. Adjust if needed. Also look for signs of damage or excessive wear
Drivetrain Boots	Check for damage
Guards	Check for damage or looseness
Nuts & Bolts	Check the wheels to see that the axle nuts are tightened. Use a wrench to make sure all accessible nuts, bolts, and fasteners are tight.
Underbody & Exhaust System	Check for, and remove, any dirt, vegetation or other debris that could be a fire hazard or interfere with the proper operation of the vehicle.
Air Cleaner Housing Drain Tube	Check for deposits in the drain tube. If necessary, clean the tube (page 166) and check the air cleaner housing.
Leaks, Loose Parts	Walk around your ATV and look for anything that appears unusual, such as a leak or loose cable.
Cable	Check the cable housings for wear. Check the fittings for looseness. Replace or tighten as needed.
Lights	Make sure the headlights, brake light and taillight are working properly.
If you are carrying cargo, also check the following:	
Loading Limits	Make sure you do not exceed the load limits
Cargo	Check that all cargo is secure.
Check these items after you get on the ATV:	
Throttle	

	Check the freeplay and adjust if needed. Press the throttle to make sure it moves smoothly without sticking, and snaps shut automatically when it is released, in all steering positions
Brakes	Squeeze the front and rear brake levers and step on the rear brake pedal to check that the controls operate normally. Depress the rear brake pedal several times, then check for proper rear brake lever/parking brake lever freeplay (page 183). Make sure there is no brake fluid leakage.
Headlights and Headlight Dimmer Switch	Check for proper function
Engine Stop Switch	Check for proper function
Steering	Check that the wheels turn properly as you steer the handlebar. Move the handlebar right and left and check that there is no excessive backlash.

Remember, be sure to take care of any problem you find, or have your dealer correct it before you ride

## Taking Care of the Unexpected

### General Guidelines

Keeping your ATV well-maintained is the best way to reduce the possibility of having a problem while riding. However, problems can arise even with well-maintained machines.

Remember to take along your owner's manual, the tool kit that came with your ATV, and any other items (such as tire repair supplies and additional tools) that might help you solve a problem on your own.

If something goes wrong during a ride, the first thing to do is stop as soon as you safely can. Do not continue riding if you have a flat tire, or you hear an unusual noise, or your ATV just doesn't feel right. If you continue riding, you could cause more damage and endanger your own safety.

After stopping, take time to assess the situation. Carefully inspect your ATV to identify the problem, then consider your options before you decide what to do.

If a problem is relatively minor and you have the tools, supplies, and skills to make a permanent repair, you may be able to fix it on the trail and continue riding. Or, you may be able to make a

temporary repair that allows you to slowly ride back to your base where you can make a permanent repair or get help.

When a problem is more serious — or you don't have the tools, supplies, experience, or time to deal with it — you need to choose the safest way to get yourself and your ATV back to base. For example, if you are close enough, you (or you and another person) might be able to push it back.

Should you ever have a problem while riding, please follow these guidelines:

- Always put personal safety first.
- Take time to assess the situation and your options before deciding what to do.
- If the problem is relatively minor and you have the tools, supplies, and skills to make a temporary repair, be sure to have permanent repairs made as soon as possible.
- Do not continue riding if you are hurt or your ATV is not in safe riding condition.

Additional recommendations for specific problems follow.

### **If Your Engine Quits or Won't Start**

Proper operation and maintenance can prevent starting and engine performance problems. In many cases, the cause of the problem may be a simple operational oversight.

If you have a problem starting the engine — or experience poor engine performance — the following information may help you. If you can't correct the problem, see your dealer.

If your ATV won't start, listen as you press the start/override button. If you don't hear the starter motor turning, refer to the *Starter motor doesn't operate* symptom. If you can hear the starter motor working normally, refer to the *Starter motor works, but the engine won't start* symptom.

SYMPTOM: <b>Starter motor doesn't operate.</b>	
POSSIBLE CAUSE	WHAT TO DO
ignition switch OFF	Turn the ignition switch ON.
engine stop switch OFF	Slide the engine stop switch to RUN.
transmission not in neutral	Shift into neutral or squeeze the front brake lever.
blown fuse	Replace with a new fuse of the same rating (page 232).
battery lead loose	Tighten the battery lead.
low (or dead) battery	Charge the battery (page 199). If charging doesn't help, see your dealer.
faulty starter motor	If all possible causes are negative, the starter motor may be faulty. See your dealer.

SYMPTOM: <b>Starter motor works, but the engine won't start.</b>	
POSSIBLE CAUSE	WHAT TO DO
out of fuel	Fill the fuel tank.
flooded engine	See <i>Flooded Engine</i> (page 87).
loose or unconnected spark plug cap	Install the spark plug cap securely. If the engine still won't start, see your dealer.
loose battery cables	Tighten the battery terminal bolts.
weak battery	Charge the battery (page 199). If charging doesn't help, see your dealer.

SYMPTOM: **Engine starts, but runs poorly.**



POSSIBLE CAUSE	WHAT TO DO
high coolant temperature	Check the coolant temperature gauge and high coolant temperature indicator. Refer to <i>If the High Coolant Temperature Indicator Lights</i> , page 230.
runs erratically, misfires	May damage catalytic converter. See your dealer.
blubbers (rich fuel mixture)	See your dealer.
sooty exhaust (rich fuel mixture)	See your dealer.
detonates or pings under load	If applicable, switch to the recommended octane gasoline (page 136) or change your brand of gasoline. If the problem persists, see your dealer.
afterfires (backfires)	May damage catalytic converter. See your dealer.
pre-ignition (runs on after ignition switched OFF)	May damage catalytic converter. See your dealer.

**SYMPTOM: Engine starts, but runs poorly or dies when hot.**

POSSIBLE CAUSE	WHAT TO DO
poor or inadequate fuel flow due to clogged fuel filter	See your dealer. (ensure clean fuel supply)

## If the Transmission Is Not Functioning Properly

When the automatic transmission is not shifting properly, the gear position indicator will show "-" and blink.

See your dealer to check and restore the transmission.

If the gear position indicator shows "-" and blink or, one or both shift switches do not function while riding, perform the following:

1. Stop the ATV.
2. Turn the ignition switch to the OFF (O) position.
3. After the engine stops, turn the ignition switch to the ON (I) position.
4. Check the gear position indicator.

If these efforts do not restore proper operation, have your ATV inspected by your dealer.

When the "-" is blinking in the gear position indicator:

Restart the engine; drive the ATV to a location where it can be loaded and transported to your dealer.

When the display on the gear position indicator returns to normal: You may drive on the ATV as usual after restarting the engine. However, we urge you to have your ATV inspected by your dealer. If one or both switches are not functioning after restarting the engine, see *Emergency Gear Selection & Operation*, page 224.

If the ATV does not move, even though "-" is not blinking in the gear position indicator:

If your ATV won't move, it is possible the transmission system has malfunctioned. Use the following procedure to manually override the clutch of the transmission.

1. Shift the transmission into 2nd gear.
2. Apply the parking brake (page 51).
3. Turn the ignition switch to the OFF (O) position.
4. Remove the oil check lid (page 142).
5. Using the gear change tool (1), loosen the screw (2) and release the lock plate (3).

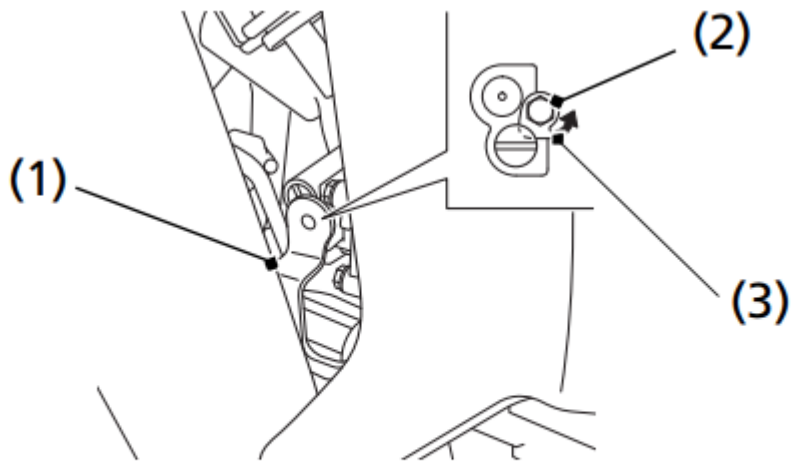

(1) gear change tool    (3) lock plate  
 (2) screw

6. Locate the emergency valve access hole (4) inside the left front fender. Using a screwdriver, turn the emergency valve (5) all the way in. With the engine running, slowly open the throttle to move the ATV forward.

7. See your dealer as soon as possible.

LEFT FRONT

LEFT SIDE

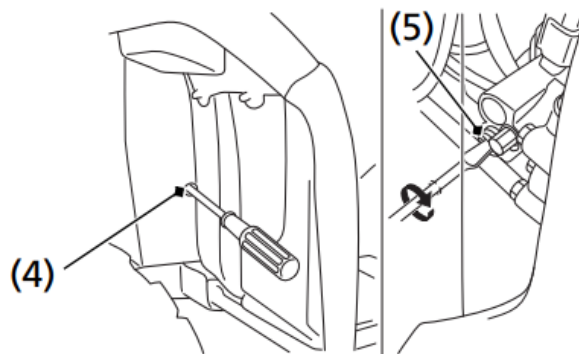

(4) emergency valve access hole    (5) emergency valve

When the battery is low (or dead):

- See *If the Battery Is Low (or Dead)*, page 239.

**Emergency Gear Selection & Operation**

If the shift switches do not operate, use the following procedure to manually select a gear so you may drive the vehicle to a location where it can be loaded and transported to your dealer.

1. Turn the ignition switch to the ON (I) position.
2. Remove the seat (page 132) and tank cover assembly (page 134).
3. Remove the gear change tool from the storage compartment (page 130).



4. Check the neutral indicator.

If the transmission is in neutral, go to step 5. If the transmission is not in neutral, use the gear change tool to shift to neutral so you will be able to start the engine. Refer to *How to Shift Gears Manually*:

5. Apply the parking brake (page 51).

6. Press the start/override button to start the engine.

7. Set 2nd gear position. Refer to *How to Shift Gears Manually*:

8. Return the gear change tool to the storage location.

9. Install the tank cover assembly and seat.

10. Get on the ATV, release the parking brake, and drive it at a safe speed to a place where it can be repaired or serviced.

#### How to Shift Gears Manually:

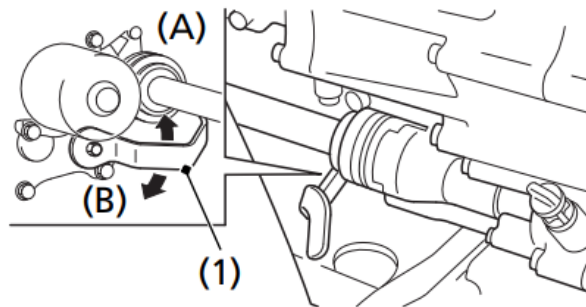

(1) gear change tool

(A) downshift (counterclockwise)

(B) upshift (clockwise)

- With the ATV unoccupied, align the hexagonal hole of the gear change tool (1) with the hexagonal end of the secondary spindle which is located on the front crankcase next to the front propeller shaft.
- To downshift, turn the gear change tool to counterclockwise (A). To upshift, turn the gear change tool to clockwise (B).
- If the transmission does not shift, rock the vehicle back and forth and try again.
- Return the gear change tool to the storage location.

Do not attempt to shift gears manually using the gear change tool while riding.

If the transmission is shifted manually when the electric shift system is functioning, the system will shutdown automatically and the shift switches will not operate. To reactivate the system, turn the ignition switch to the OFF (o) position, then turn it back to the ON (I) position.

It may be required to rock the ATV back and forth to get proper transmission gear alignment to allow shifting between gears.

## **If You Have a Flat Tire**

How you handle a flat tire on the trail depends on how serious the tire damage is, and what tools and supplies you have with you.

If you have a slow leak or a minor puncture, use the plug method to make a temporary repair. (The plug method is applied from the outside of the tire and is the same as that for conventional tubeless tires.)

A plug-type repair kit, available at most auto parts stores or service stations, provides a plug, an installation tool, tire cement, and an instruction sheet. Follow the instructions provided with the repair kit to make a temporary repair.

As soon as possible, have the tire permanently repaired by your dealer. Any tire that cannot be repaired should be replaced.

Whenever the ATV is to be operated far from service facilities or available transportation, we recommend that you carry a tire pump and a repair kit with the vehicle.

If the leak is more serious, or a temporary repair doesn't hold, the tire must be replaced. The tire will also need to be replaced if it is damaged (page 192). Replacing a tire involves removing and reinstalling the wheel (page 228).

If you are unable to repair a flat tire on the trail, you will need to send for help. We strongly recommend that you do not try to ride with a flat tire. The ATV will be hard to handle, and if the tire comes off the rim, it may lock up the wheel and cause you to crash.

## **Emergency Wheel Removal/Installation**

TRX520FA5/FA6  
(Steel wheel model):

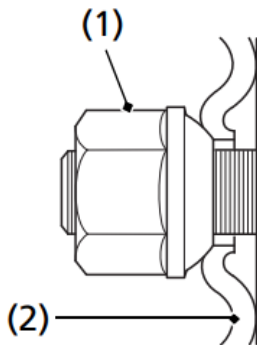
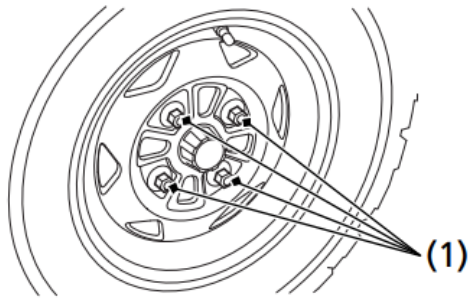

Wheel nuts:  
47 lbf-ft (64 N·m, 6.5 kgf·m)

(1) wheel nuts

TRX520FA7  
(Aluminum wheel model):

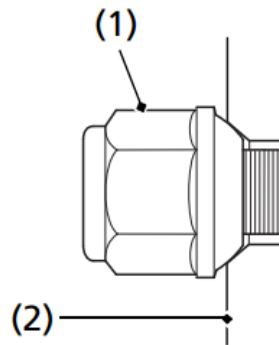
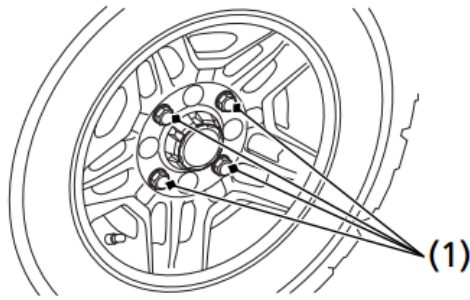

Wheel nuts:  
62 lbf-ft (84 N·m, 8.6 kgf·m)

(2) wheel rim

### Removal

1. Park your ATV on a firm, level surface.
2. Loosen — but do not remove — the wheel nuts (1).
3. Raise the front (or rear) wheels off the ground and place a support block under the vehicle.
4. Remove the wheel nuts.
5. Remove the wheel.
  - Avoid getting grease, oil, or dirt on the front brake disc or pad surfaces when removing and installing each wheel. Any contamination can cause poor brake performance or rapid pad wear after reassembly.

### Installation

1. Position the wheel.
2. Position each wheel nut so that the tapered side faces the wheel rim (2).
3. Hand-tighten the wheel nuts on the wheel, then lower the ATV to the ground before tightening the nuts in a crisscross (rather than circular) pattern to the specified torque:

TRX520FA5/FA6 (Steel wheel model):

47 lbfft (64 Nm, 6.5 kgfm)

TRX520FA7 (Aluminum wheel model):

62 lbfft (84 Nm, 8.6 kgfm)

If a torque wrench was not used for installation, see your dealer as soon as possible to verify proper assembly. Improper assembly may lead to loss of braking capability.

## **If the High Coolant Temperature Indicator Lights**

Normally, the high coolant temperature indicator will only light momentarily when you turn the ignition to ON (I).

High coolant temperature may be caused by restriction of air flow to the radiator (such as mud caked on the radiator), extended idling, an oil leak, a coolant leak, a low oil level, a low coolant level, or extended operation under adverse conditions.

If the all segment of the coolant temperature gauge and high coolant temperature indicator are on while you're riding, don't ignore it. Pull safely to a stop. Stop the engine as soon as it's safe to do so, and let it cool.

*NOTICE Continuing to ride with high coolant temperature or an overheated engine can cause serious engine damage.*

- A steaming engine indicates a coolant leak. Shut the engine off and wait until the steaming stops. Look for a leak, but don't touch the engine or radiator system. Let everything cool off first.
- Check for any restriction of air flow to the radiator.
- If there's no obvious problem, leave the engine on so the fan and coolant circulating system can continue working. Monitor the coolant temperature gauge and high coolant temperature indicator. The indicator may turn off after a brief stop with no load on the engine.
- Check the radiator fan.

If the fan is not working, turn the engine off. Open the fuse box (page 233) and check the radiator fan fuse. If the fuse is blown, replace it with the proper (same rating) spare fuse. Start the engine. If the all segment of the coolant temperature gauge and high coolant temperature indicator stays on, turn the engine off. If the radiator fan is working, visually check the coolant level in the reserve tank, located under the left front fender. It isn't necessary to touch the radiator system.

- If the reserve tank is low or empty, don't ride without adding coolant (page 154). After adding coolant, turn the engine on and check the coolant temperature gauge and high coolant temperature indicator.

If the indicator doesn't turn off, do not ride. The engine needs repair.

Transport your ATV to your dealer (page 208).

If the temperature drops to normal, check the coolant level. If it has gone down, add more coolant.

- Check for an oil leak.
- Check the oil level. If necessary, add the recommended oil (page 142) to the upper level mark. If you must leave your ATV to get oil, secure it as much as possible.
- Start the engine, and check that the coolant temperature gauge and high coolant temperature indicator goes off.

If you are able to resume riding, continue to monitor the coolant temperature gauge and high coolant temperature indicator frequently.

If there is an oil leak — do not ride the ATV until the leak is repaired by your dealer (page 208).

If there's a mild coolant leak, you can ride for awhile, carefully watching the coolant temperature gauge and indicator. Be prepared to stop and add more coolant or water. If the leak is bad, transport your ATV to your dealer (page 208).

## If a Fuse Blows

All of the electrical circuits on your ATV have fuses to protect them from damage caused by excess current flow (short circuit or overload).

If something electrical on your ATV stops working, the first thing you should check for is a blown fuse (1).

Check all the fuses before looking elsewhere for another possible cause of the problem. Replace any blown fuses and check component operation.

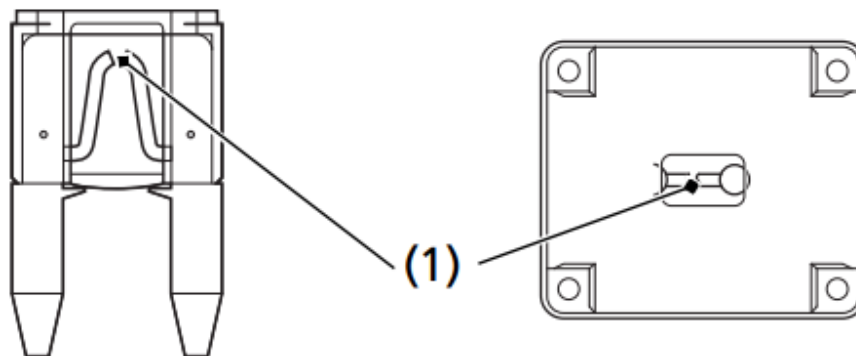

### (1) blown fuse

The main fuse and the circuit fuses are located under the rear fender cover.

TRX520FA6/FA7:

The EPS (Electric Power Steering) fuse is located under the rear fender cover.

#### Recommended Fuses

main fuse 1	40 A
main fuse 2	10 A
ES (shift motor) fuse	30 A
other fuses	20 A × 3, 10 A
EPS (Electric Power Steering) fuse (TRX520FA6/FA7)	40 A

#### *Main Fuses Access*

1. To prevent an accidental short circuit, turn the ignition switch to OFF (O) before checking or replacing the fuses.
2. Remove the seat (page 132).
3. Remove the rear fender cover (page 133).
4. To access the main fuse 1 (2), remove the fuse cover (3).
5. To access the main fuse 2 (4), remove the fuse box cover (5).

UNDER REAR FENDER COVER

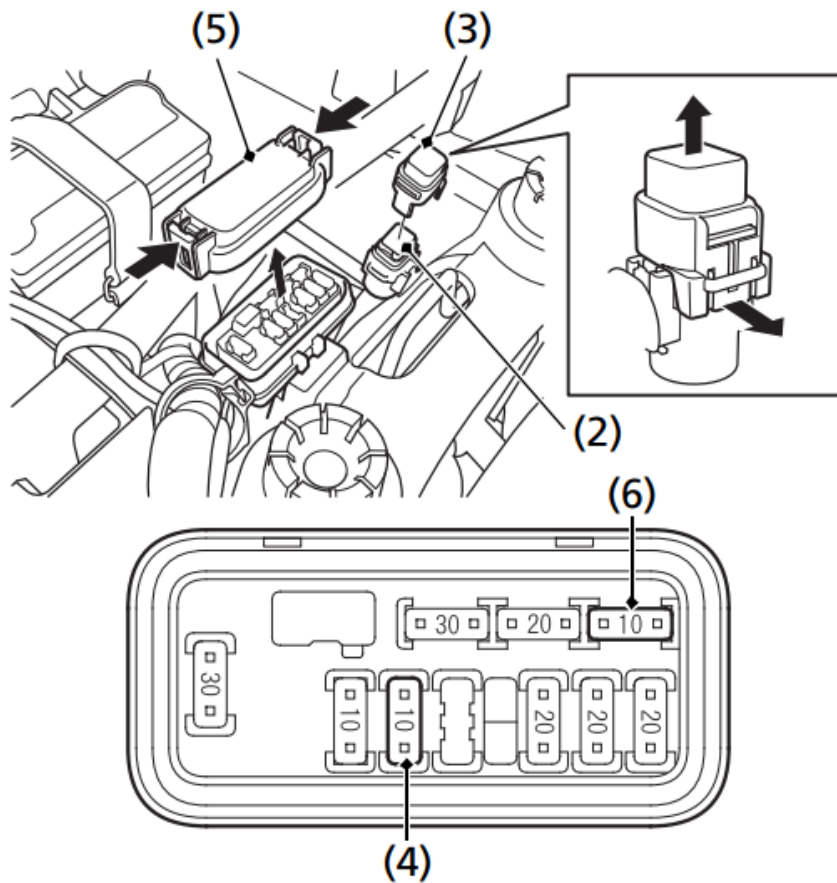

(2) main fuse 1  
 (3) fuse cover  
 (4) main fuse 2

(5) fuse box cover  
 (6) spare fuse

6. Pull the main fuse 1 (2) out. If the main fuse 1 is blown, install the spare fuse on the underside of the rear fender cover (page 131).

7. Pull the main fuse 2 (4) out with the fuse puller on the underside of the rear fender cover (page 131).

If the main fuse 2 is blown, install the spare fuse (6).

8. Install the fuse cover.

## Circuit Fuses Access

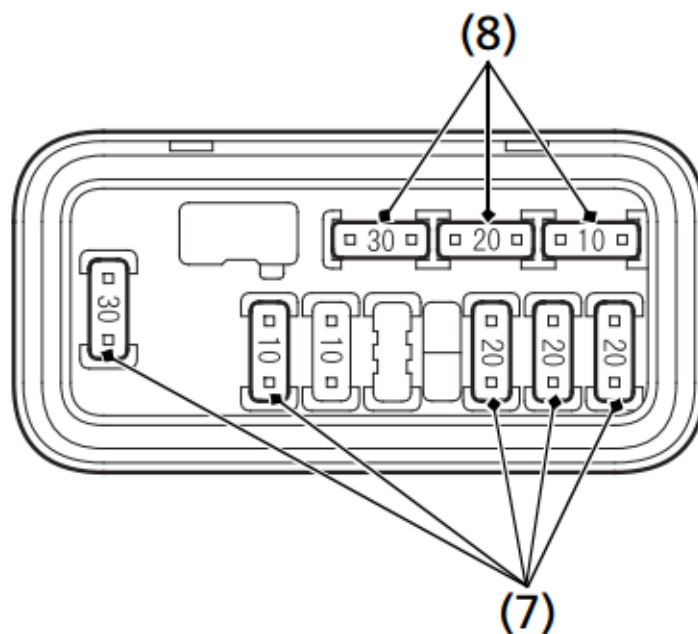

(7) circuit fuses

(8) spare fuses

9. To check or replace a circuit fuse (7), pull the old fuse out of its retaining clips with fuse puller on the underside of the rear fender cover (page 131).

If the fuse is blown, replace it with a spare fuse (8) of the same rating.

If you do not have a replacement fuse with the proper rating for the circuit, install one with a lower rating.

*NOTICE* Replacing a fuse with one that has a higher rating greatly increases the chance of damage to the electrical system.

10. Install the fuse box cover.
11. Install the rear fender cover.
12. Install the seat.

### EPS (Electric Power Steering) Fuse Access (TRX520FA6/FA7)

1. Turn the ignition switch to OFF (O) before checking the fuse.
2. Remove the seat (page 132).
3. Remove the rear fender cover (page 133).
4. To access the EPS fuse (1), remove the EPS fuse box cover (2). If the EPS block fuse is blown, install the spare fuse (page 131).
5. Install the EPS fuse box cover.
6. Install the rear fender cover.

7. Install the seat.

## UNDER REAR FENDER COVER

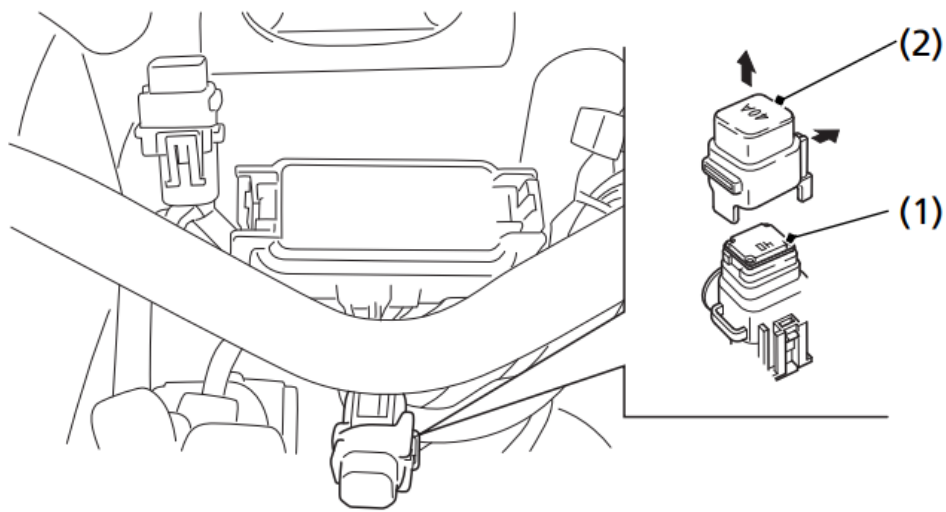

(1) EPS fuse

(2) EPS fuse box cover

If you do not have a spare fuse and you cannot ride the ATV without fixing the problem, take a fuse of the same rating or a lower rating from one of the other circuits that you can do without temporarily.

If you replace a blown fuse with a spare fuse that has a lower rating, replace the fuse with the correct rating as soon as you can. Also remember to replace any spare fuses that were installed.

If the replacement fuse of the same rating burns out in a short time, there is probably a serious electrical problem on your ATV. Leave the blown fuse in that circuit and have your ATV checked by your dealer.

### If You Crash

Personal safety is your first priority after a crash. If you or anyone else has been injured, take time to assess the severity of the injuries and whether it is safe to continue riding. If you cannot ride safely, send someone for help. Do not ride if you will risk further injury.

If you decide you are capable of riding safely, carefully inspect your ATV for damage and determine if it is safe to ride. Check the tightness of critical nuts and bolts securing such parts as the handlebar, control levers, brakes, and wheels.

If there is minor damage, or you are unsure about possible damage but decide to try riding the ATV back to your base, ride slowly and cautiously.

Sometimes, crash damage is hidden or not immediately apparent. When you get home, thoroughly check your ATV and correct any problems you find. Also, be sure to have your dealer check the frame and suspension after any serious crash.

### **If You Lose Your Key**

Be sure to record your key number (1). Store the spare key and recorded key number in a safe location. You'll need this number to have a duplicate key made.

If you lose your key and aren't carrying a duplicate, either get your spare or have one made. If you don't know your key number, call the dealer where you purchased your Honda ATV. They may have it listed in their records. If they don't, transport your ATV to them or the nearest dealer. The dealer will probably have to remove the ignition switch assembly to find the key number so they can make a key for you.

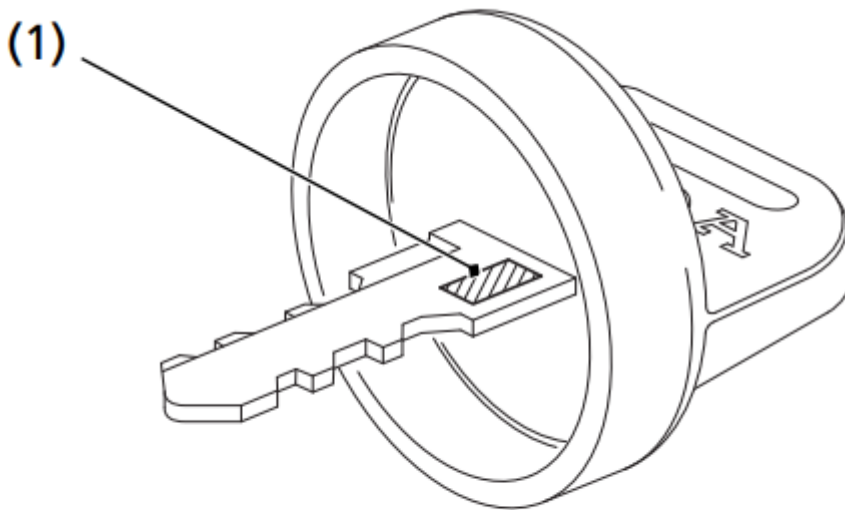

### **(1) key number**

### **If the Battery Is Low (or Dead)**

Jump starting is not recommended, especially if you use an automobile battery. The greater amperage of an automobile battery when the car engine is running can damage your ATV's electrical system.

Bump starting is also not recommended.

If you can't charge the battery or it appears unable to hold a charge, contact your dealer.

### **(Canada only)**

Your ATV will operate even if the battery is low (or dead), as long as the engine is running. If the engine is not running, it may be started using the recoil starter.

1. Turn the ignition switch to the ON (I) position.
2. Check if the transmission is in neutral by moving the vehicle back and forth.
3. If the transmission is in neutral, the vehicle will move easily. Go to step 6. If the transmission is not in neutral, the vehicle will not move.
4. Remove the gear change tool from the storage compartment (page 130).
5. Use the gear change tool to shift to neutral so you will be able to start the engine. Refer to *How to Shift Gears Manually*(page 225).
6. Apply the parking brake.
7. Turn the ignition switch to the OFF (O) position, then turn it back to the ON (I) position.
8. Use the recoil starter (page 90) to start the engine.

## If a Component Fails

The brake levers or pedal, control cables, and other components can be damaged as you ride in dense brush or over rocky terrain. Making a trailside repair depends on how serious the damage is and what tools and supplies you have with you.

- If any component of the brake system is damaged, you may be able to ride carefully back to your base using the other brake components for slowing or stopping.
- If you damage a throttle cable or other critical component, your ATV may be unsafe to ride. Carefully assess the damage and make any repairs that you can. But if there is any doubt, it's best to be conservative and safe.

### Warning

This content is compiled from multiple sources and is provided for reference purposes only. It may not be complete or fully applicable to all situations. If you are unable to resolve your issue, please contact the product manufacturer or an authorized service provider for official support.