

## User Guide for TV

### Before setting up your TV

Some TV models are packaged with a detached Table-Top Stand so you can mount your TV to a wall right away. See page 13 (Installing the TV to the Wall) if you want to mount the TV to a wall. If you are not mounting the TV to a wall, you will need to attach the Table-Top Stand. You will need a Phillips screwdriver (not supplied) and the supplied screws to complete the task, refer to the Setup Guide.

Be sure to consider the following while setting up your TV:

- Disconnect all cables when carrying the TV.
- Carry the TV with the adequate number of people; larger size TVs require two or more people (three or more people for XBR-85X900F).
- Correct hand placement while carrying the TV is very important for safety and to avoid damage.

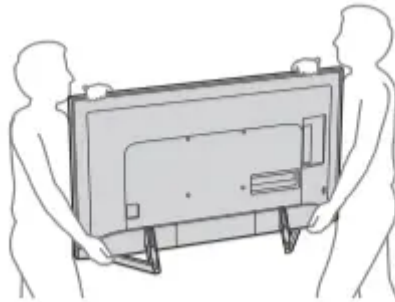

- Ensure your TV has adequate ventilation, see page 15.
- For best picture quality, do not expose the screen to direct illumination or sunlight.
- Avoid installing the TV in a room with reflective wall and floor materials.
- Avoid moving the TV from a cold area to a warm area. Sudden room temperature changes may cause moisture condensation. This may cause the TV to show poor picture and/or poor color. Should this occur, allow moisture to evaporate completely before powering the TV on.

### Securing the TV



Sony strongly recommends taking measures to prevent the TV from toppling over.

Unsecured TVs may topple and result in property damage, serious bodily injury or even death.

## Preventing the TV from Toppling

- Secure the TV to a wall and/or Stand.
- Do not allow children to play or climb on furniture and TV sets.
- Avoid placing or hanging items on the TV.
- Never install the TV on:
  - Slippery, unstable and/or uneven surfaces.
  - Furniture that can easily be used as steps, such as a chest of drawers.
- Install the TV where it cannot be pulled, pushed, or knocked over.
- Install the TV so that the TV's Table-Top Stand does not protrude out from the Stand (not supplied). If the Table-Top Stand protrudes out from the Stand, it may cause TV set to topple over, fall down, and cause personal injury or damage to the TV.

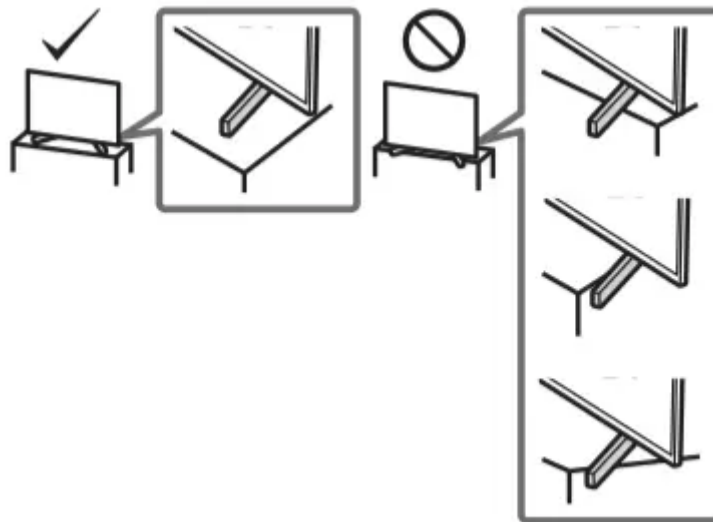

- Route all AC power cords and connecting cables so that they are not accessible to curious children.

## Recommended Measures to Secure the TV

Consider the following measures when securing your TV to a Stand (not supplied).

1. Secure the Stand for the TV.

Make sure the Stand can adequately support the weight of the TV. Use two angle braces (not supplied) to secure the Stand. For each angle brace use the appropriate hardware to:

- Attach one side of the angle brace to the wall stud.
- Attach the other side to the Stand.

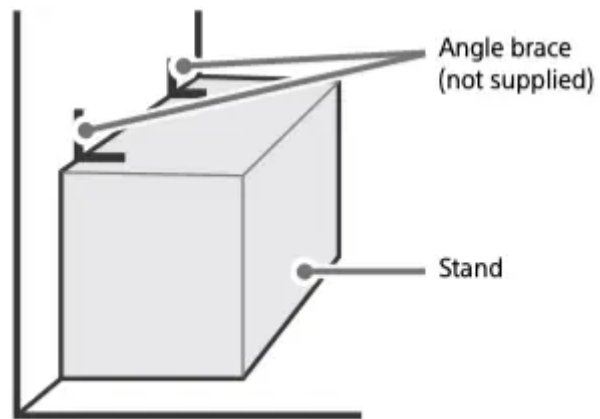

2. Secure the TV to the Stand.

Use the optional hardware listed as follows (not supplied):

- M6 machine screws (screwed into the TV's rear cover).
- A screw or similar (attach it to the Stand).
- Rope or chain (strong enough to support the weight of the TV). Make sure that there is no excess slack in the rope or chain.

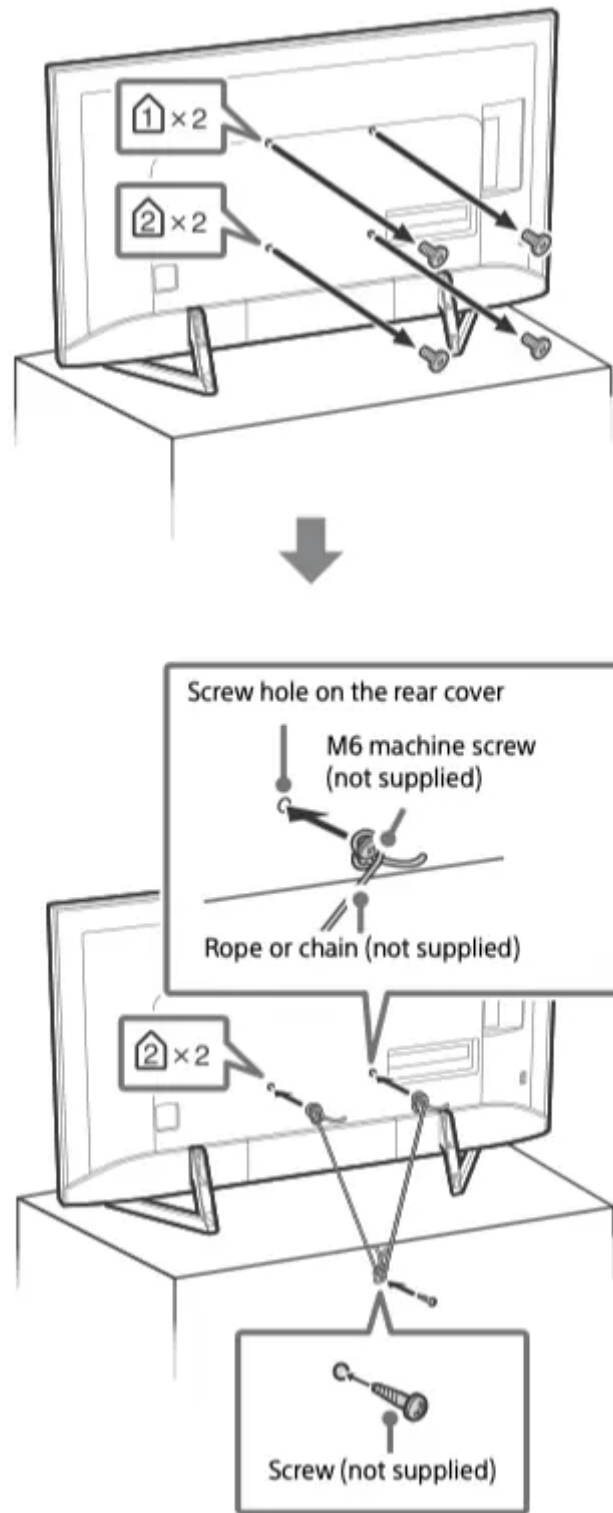

The length of the M6 machine screw differs depending on the rope or chain diameter. Please refer to below illustration.

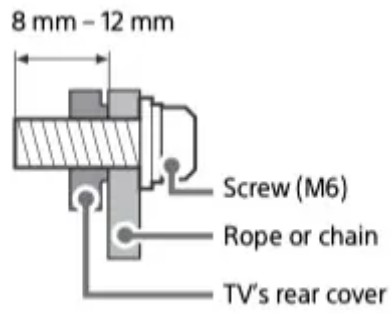

3. Anchor the TV to the wall by using bolts, wall anchor and chain (or rope).

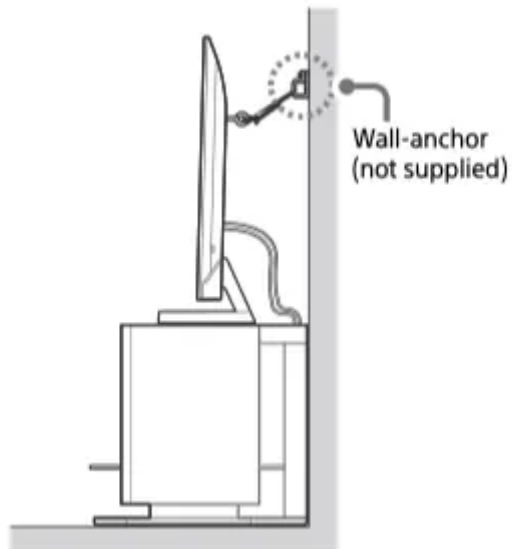
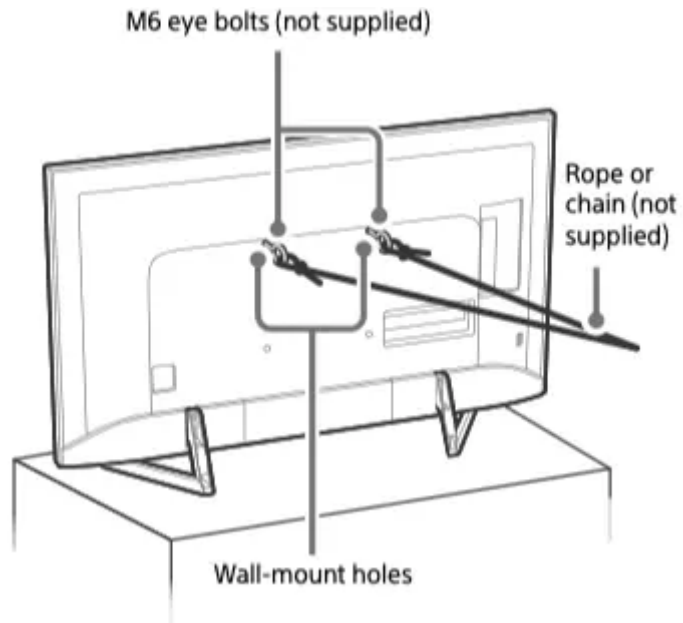

Please see below illustration for M6 eye bolt length.

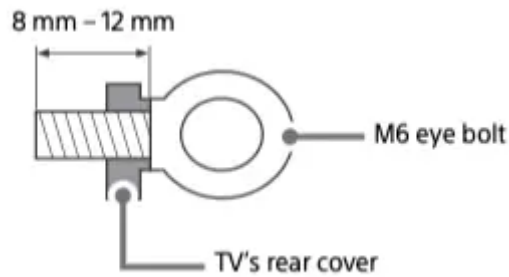

## Note

- Your TV is shipped with screws attached to the rear of the TV depending on the TV model. (They are fastened in the screw holes for wall mounting.) Be sure to remove the upper two screws prior to anchoring the TV to a wall.
- Securing the TV to the Stand without securing the TV and the Stand to the wall provides minimum protection against the TV toppling over. For further protection, be sure to follow the three measures recommended.

## Precautions

### How to care for your BRAVIA TV

Safety is very important. Please read and follow the safety documentation (Safety Booklet) separately provided. Unplug the TV and other connected equipment from the wall outlet before you begin cleaning your TV.

- Wipe the LCD screen gently with a soft cloth.
- Stubborn stains may be removed with a cloth slightly moistened with a solution of mild soap and warm water.
- If using a chemically pretreated cloth, please follow the instruction provided on the package.



- Never spray water or detergent directly on the TV set. It may drip to the bottom of the screen or exterior parts and enter the TV set, and may cause damage to the TV set.
- Never use strong solvents such as a thinner, alcohol or benzene for cleaning.
- Do not plug in the TV into the wall outlet until the moisture from cleaning has evaporated.
- Do not touch the TV if your hand is covered in any chemical substance such as hand cream or sunblock. The TV should also be placed on a stable surface to prevent it from

toppling over (see page 4). If you have young children or pets at home, check regularly to ensure the TV is securely fastened.



### **Recommendation for an F type plug**

Projection of the inner wire from the connection part must be less than 1.5 mm.

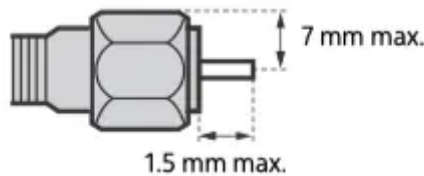

(Reference drawing for an F type plug)

### **Four Steps to a 4K TV Experience**

Set, Source, Sound, and Setup.

#### 1. Set

Now that you have made the best selection in LED backlit LCD TV technology, be sure to remove all of the accessories from the packaging before setting up your TV.

#### 2. Source

To experience the stunning detail of your BRAVIA TV, you need access to HD programming.

- Upgrade your signal or content source to high-definition (4K) by contacting your HD service provider.
- Bring the astonishing resolution of your Sony 4K Ultra HD TV to life with Sony 4K Ultra HD Blu-ray Player. (The availability depends on region)
- Receive over-the-air HD broadcasts with an HD-quality antenna connected directly to the back of your TV.

Visit antennaweb for more information on antenna selection and setup.

- Discover the wealth of entertainment now available on super-high resolution Blu-ray Disc™ player and other Sony HD equipment.

#### 3. Sound

Complete the high-definition experience with a BRAVIA Sync™ surround sound system or A/V receiver from Sony.

## 4. Setup

Install your TV and connect your sources. See page 11 for sample connection diagrams. To help assure the highest quality for your HD experience, use Premium High Speed HDMI (High-Definition Multimedia Interface) cables.

### Note

- For details of supported formats, refer to the “Specifications” in this manual.
- For supported PC formats, refer to the Help Guide.

## Parts and Controls

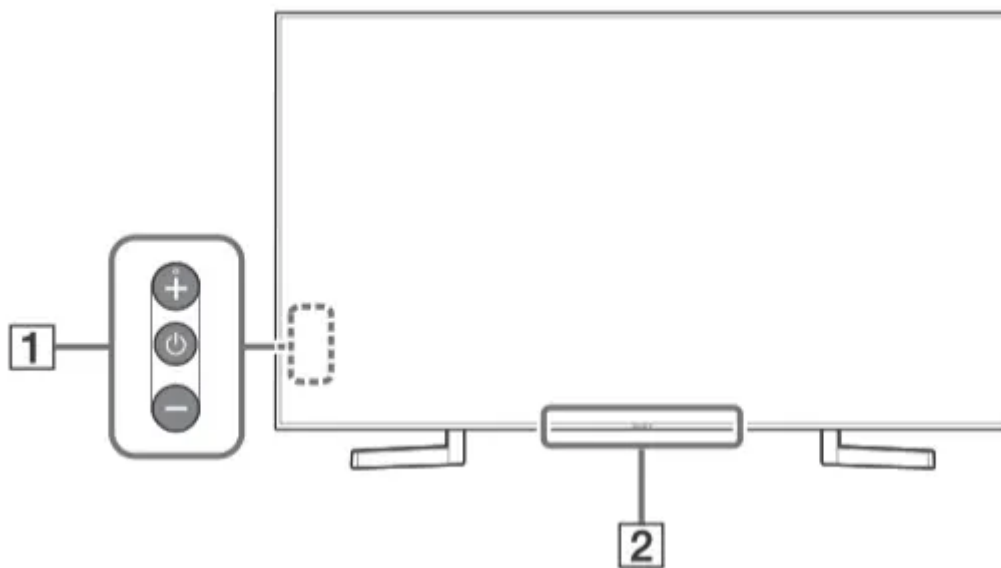



### 1. (Power) /+/-

When the TV is off,

Press  to power on.

When the TV is on,

Press and hold  to power off. Press  repeatedly to change the function, then press + or – button to:

- Adjust the volume.
- Select the channel.
- Select the input source of TV.

### 2. Remote Control sensor\* / Light sensor\* / Illumination LED

The illumination LED lights up or blinks according to the status of the TV.

For more information, refer to the Help Guide.





\* Do not place anything near the sensor.

## Using Remote Control

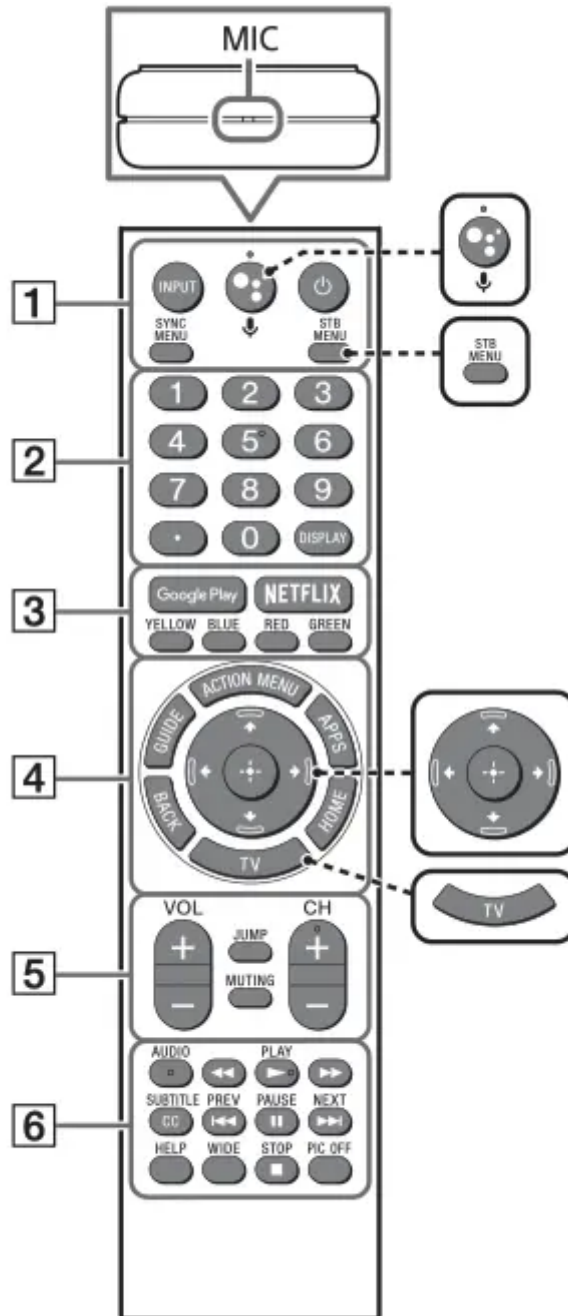
### Remote Control Parts Description

The remote control shape, location, availability and function of remote control buttons may vary depending on your region/country/TV model.



	<p><b>●●● (Google Assistant) /  (Microphone)</b></p> <p>Use the Google Assistant* (only on limited region/country/language/TV model) or Voice Search. (e.g., Search various content by voice.)</p>
	<p><b>STB MENU</b></p> <p>Display the connected Set Top Box (cable/satellite box) menu after connecting and setting up the IR Blaster (page 12).</p>
	<p><b>↑/↓/←/→/⊕ (Navigation D-Pad)</b></p> <p>On screen menu navigation and selection.</p>
	<p><b>TV</b></p> <p>Switch to a TV channel or input and display the TV Menu Bar.</p>

## 1. INPUT

Display and select the input source.

 (TV standby)

Turn on or turn off the TV (standby mode).

## SYNC MENU

Display the BRAVIA Sync Menu.

## 2. Number buttons

 Use with the 0-9 buttons to select digital channels.

## DISPLAY

Display information about the channel/ program/input you are viewing.

## 3. Google Play

Access the “Google Play” online service.

## NETFLIX (Only on limited region/ country/TV model)

Access the “NETFLIX” online service.

### **Color buttons**

Execute corresponding function at that time.

### **4. ACTION MENU**

Display a list of contextual functions.

### **GUIDE**

Display the digital program guide.

### **APPS**

Access various services and applications.

### **BACK**

Return to the previous screen.

### **HOME**

Display the TV Home Menu.

### **5. VOL +/- (Volume)**

Adjust the volume.

### **JUMP**

Jump back and forth between two channels or inputs. The TV alternates between the current channel or input and the last channel or input that was selected.

### **MUTING**

Mute the sound. Press again to restore the sound.

### **CH +/- (Channel)**

Select the channel.

### **6. AUDIO**

Change the language for the program currently being viewed.



Operate media contents on the TV and connected BRAVIA Sync-compatible device.

### **SUBTITLE/CC**

Turn subtitles on or off (when the feature is available).

### **HELP**

Display the Help menu. Help Guide can be accessed from here.

### **WIDE**

Change the screen format.

### **PIC OFF**

Turn the picture off, while sound remains on.

### **Guidelines for IR Remote Control**

- Point your remote control directly at the IR sensor located on your TV.
- Make sure that no objects are blocking the path between the remote control and the IR sensor on your TV.

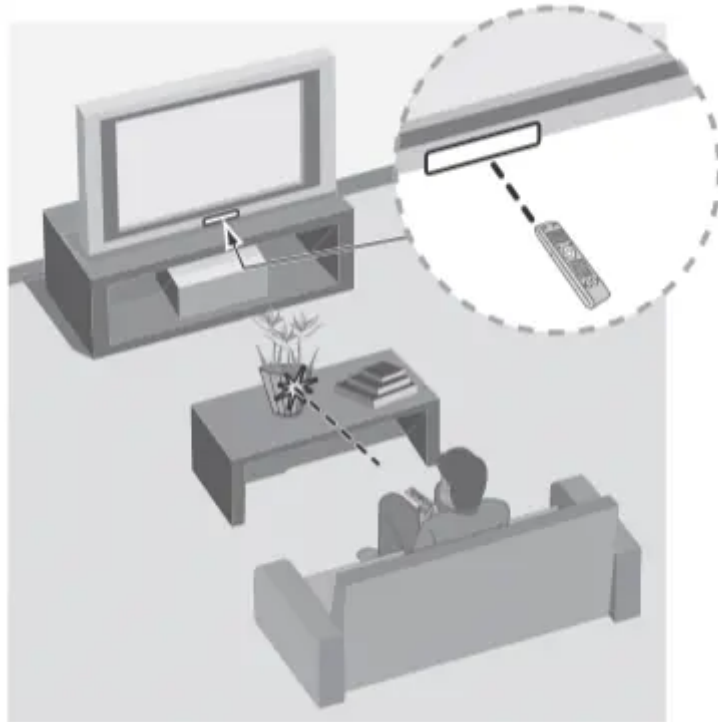

- Fluorescent lamps can interfere with your remote control; try turning off the fluorescent lamps.
- If you are having problems with the remote control, reinsert or replace your batteries and make sure that they are correctly inserted.

## **Connection Diagram**

For more information on connections, refer to the Help Guide by pressing HELP on the remote control.

### **Note**

- When connecting the cable to the Cable/Antenna input, finger tighten only, over tightening the connection can damage the TV.

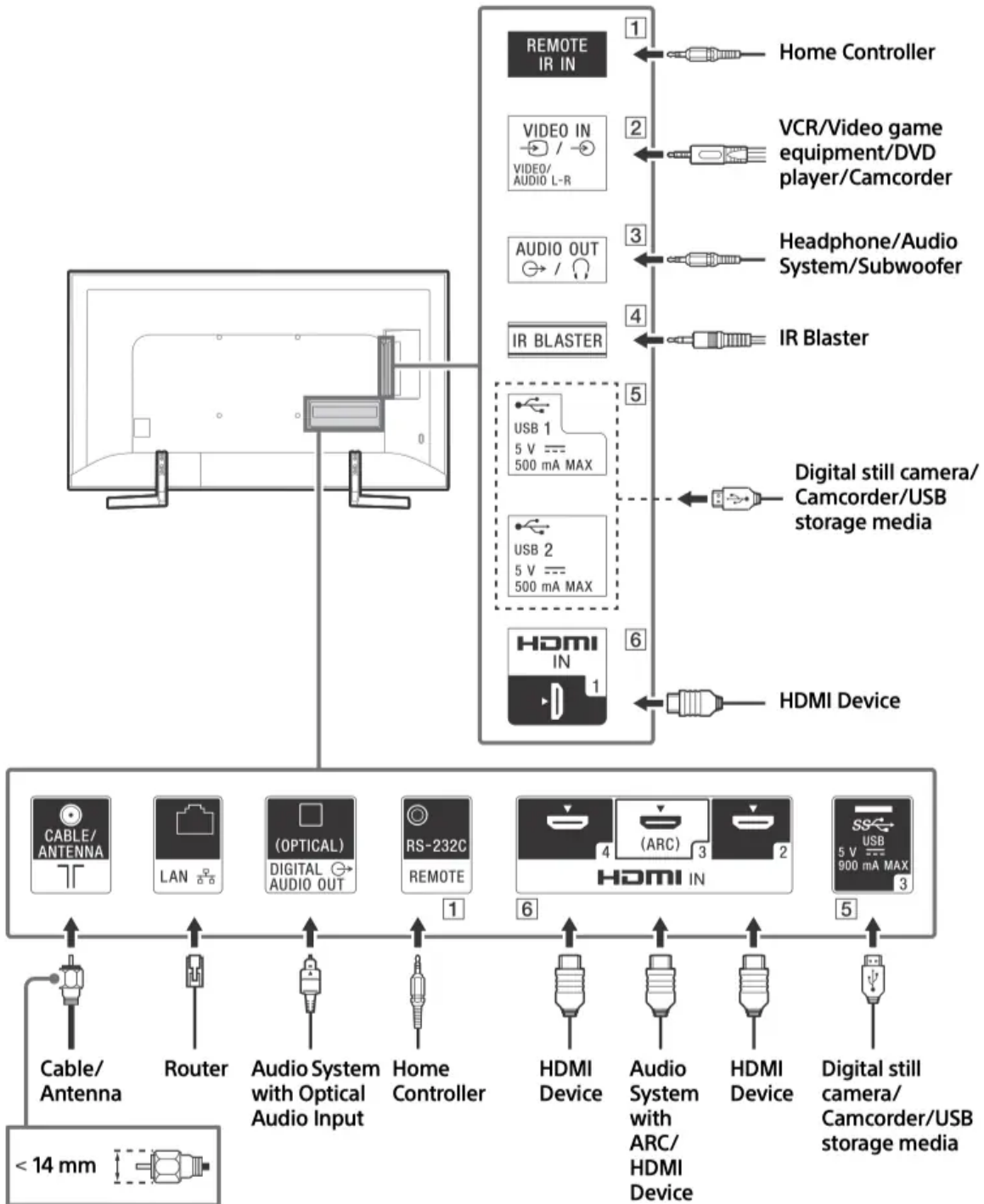

## 1. REMOTE RS-232C REMOTE IR IN

- These jacks are for receiving the external control signal. Enables extended control of the TV using RS-232C via the RS-232C and IR IN jacks.

RS-232C: connect to the RS-232C terminal of the home controller.

IR IN: connect to the IR out terminal of the home controller.

- Take care to not connect to headphones or an external audio system.

## 2. VIDEO IN

- For a composite connection, use an Analog Extension Cable (not supplied).

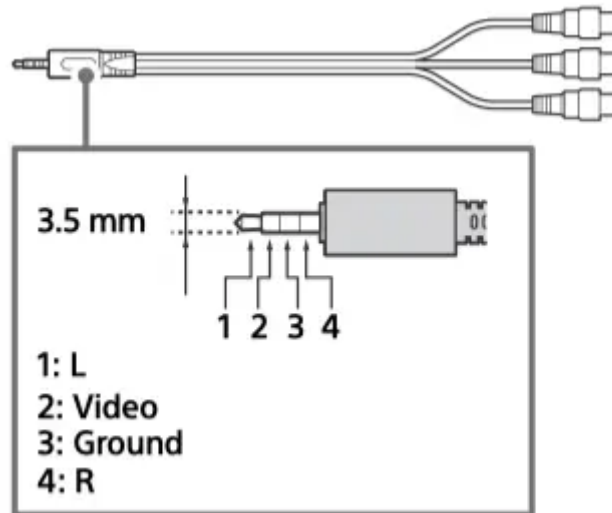

## 3. AUDIO OUT

- Supports 3-pole stereo mini jack only.
- To listen to the TV's sound through the connected equipment, press HOME. Select [Settings] → [Sound] → [Headphone/Audio out] and then select the desired item.

## 4. IR BLASTER\*

- Use your Sony remote control to control your Set Top Box (cable/ satellite box). Connect the IR Blaster Cable (supplied) to the IR Blaster port on your TV. Place one or both of the other two ends as shown below.

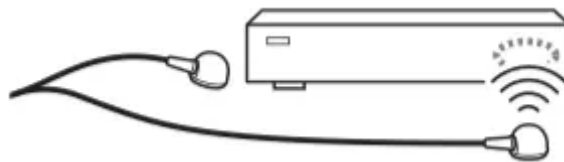

- To perform IR Blaster setup, press HOME and select [Settings] → [External inputs] → [IR Blaster setup].

## 5. USB 1/2, USB 3

- Connecting a large USB device may interfere with other connected devices beside it.
- When connecting a large USB device, connect to the USB 1 port.

## 6. HDMI IN 1/2/3/4

- HDMI interface can transfer the digital video and audio on a single cable.

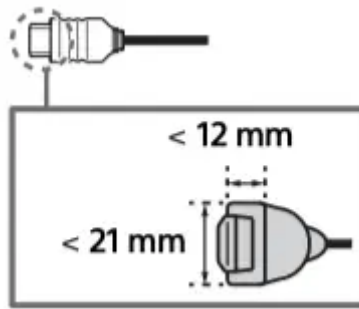

- **HDMI IN 3 ARC (Audio Return Channel)**

Connect your audio system to the HDMI IN 3 to route TV audio to your audio system. An audio system that supports HDMI ARC can send video to the TV, and receive audio from the TV via the same HDMI cable. If your audio system does not support HDMI ARC, an additional connection with DIGITAL AUDIO OUT (OPTICAL) is necessary.

\* Only on limited region/country/TV model.

## Installing the TV to the Wall

This TV's instruction manual only provides the steps to prepare the TV for Wall-Mount installation before it is installed on the wall.

Your TV can be mounted on a wall using a Wall-Mount Bracket (not supplied) out of the box as packaged. If the Table-Top Stand is attached to the TV, the TV may require detaching the Table-Top Stand; see page 14 (Detaching the Table-Top Stand from the TV).

Prepare the TV for the Wall-Mount Bracket before making cable connections.

**For product protection and safety reasons, Sony strongly recommends that installation of your TV on the wall be performed by qualified professionals. Do not attempt to install it yourself.**

- Follow the instruction guide provided with the Wall-Mount Bracket for your model. Sufficient expertise is required in installing this TV, especially to determine the strength of the wall for withstanding the TV's weight.
- The length of the screw for Wall-Mount Bracket differs depending on the Wall-Mount Bracket thickness. Please see below illustration.

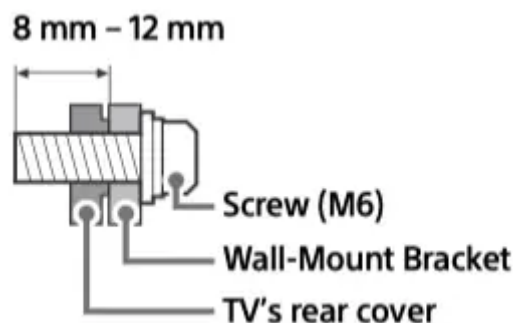

- Be sure to store the unused screws and Table-Top Stand in a safe place until you are ready to attach the Table-Top Stand. Keep the screws away from small children.

**Note**

- Read the supplied Safety Booklet for additional safety information.
1. Remove the screws from the rear of the TV.

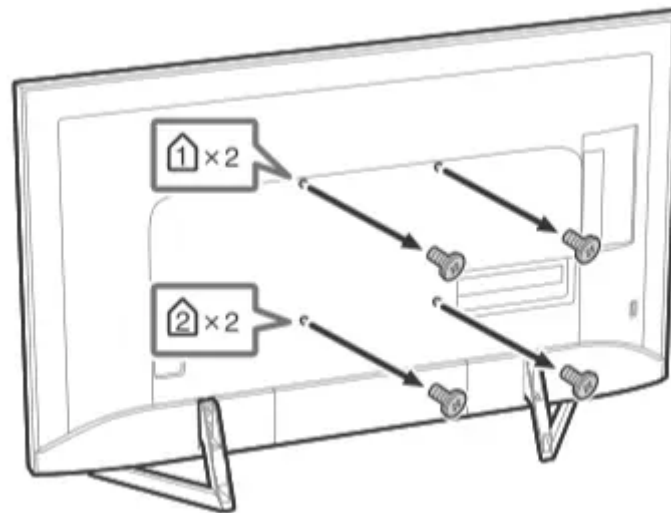

2. Attach the Wall-Mount Bracket (not supplied) using the screws (not supplied).

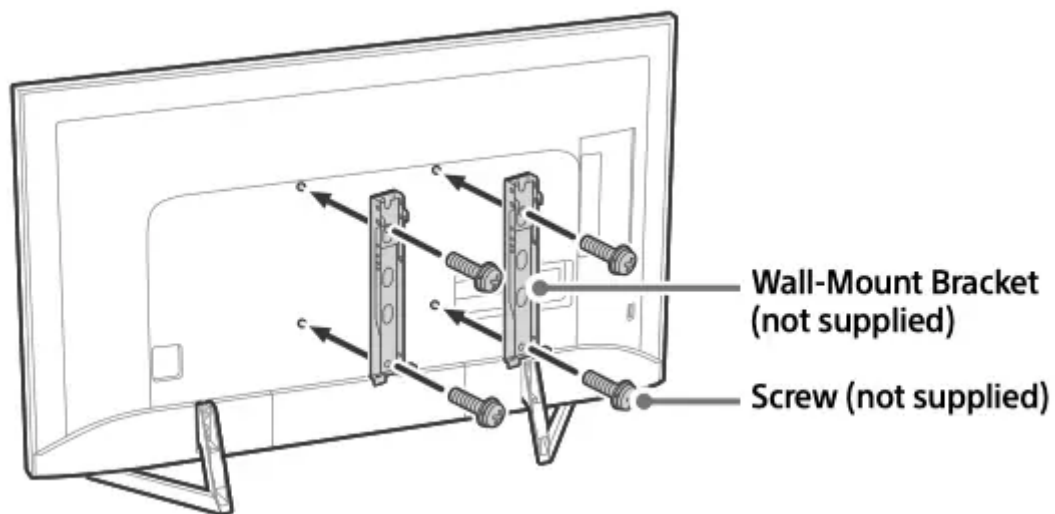

**Detaching the Table-Top Stand from the TV**

To detach the Table-Top Stand from the TV, remove the screws .

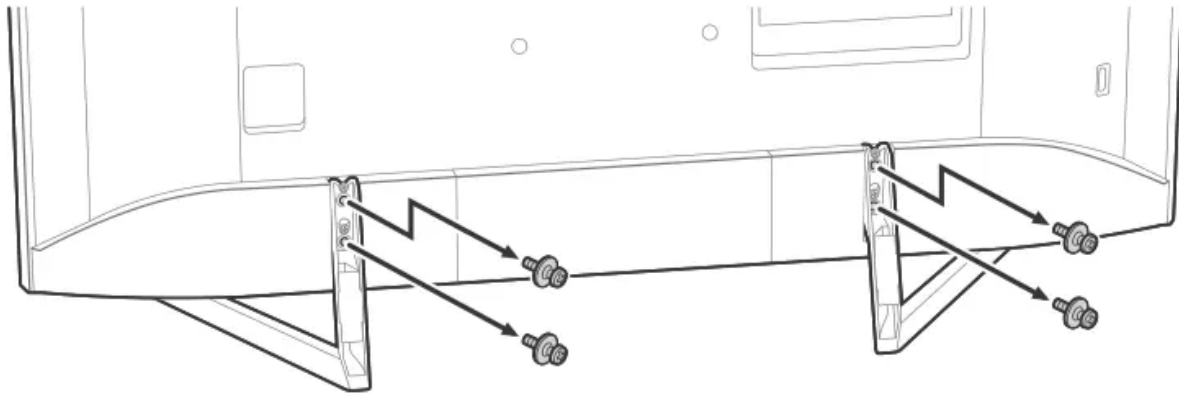

**Note**

- Do not remove the Table-Top Stand for any reason other than to install corresponding accessories on the TV.
- Be sure the TV is vertical before turning on. To avoid uneven picture uniformity do not power on the TV with the LCD panel facing down.
- When attaching the Table-Top Stand again, be sure to fasten the screws (previously removed) to the original holes on the rear of the TV.

**Installing the TV against a wall or enclosed area**

**Ventilation**

- Never cover the ventilation holes or insert anything in the cabinet.
- Leave space around the TV set as shown below.

**Installed with stand**

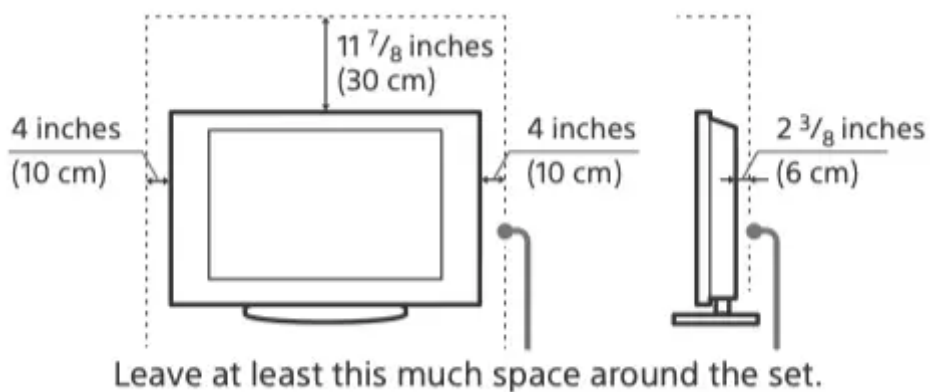

**Installed on the wall**



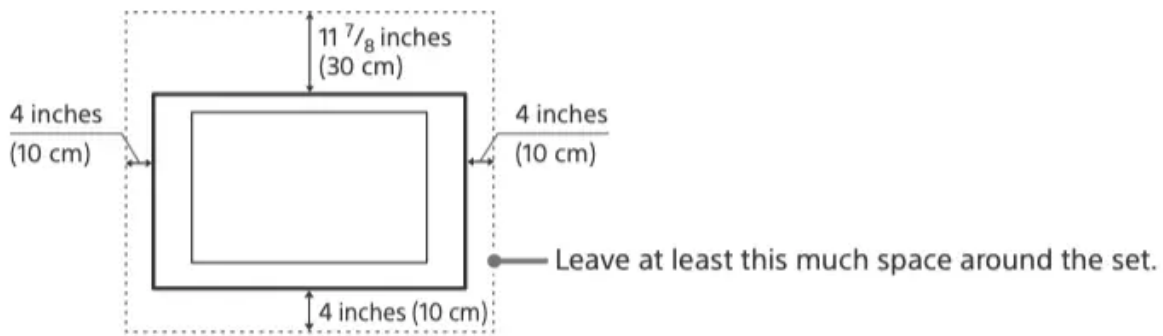

**Never install the TV set as follows:**

Air circulation is blocked.

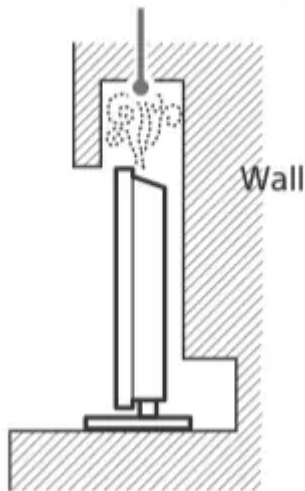

Air circulation is blocked.

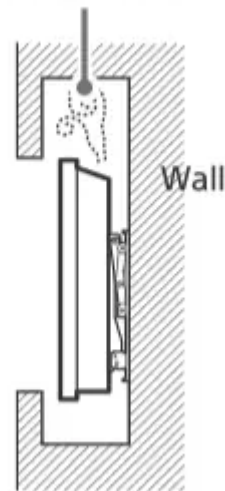

**Note**

- Inadequate ventilation can lead to overheating of the TV and may cause damage to your TV or cause a fire.

## Troubleshooting

General troubleshooting for issues like: black screen, no sound, frozen picture, TV does not respond, or network is lost, do the following steps.

1. Restart your TV by pressing the power button on the remote control until a message appears. The TV will restart. If the TV does not recover, try unplugging the TV from the AC power cord for two minutes and then plug it in again.
2. Refer to the Help menu by pressing HELP on the remote control.
3. Connect your TV to the Internet and perform a software update.
4. Visit Sony support website (information provided on the front cover).
5. Perform the factory data reset. Refer to “How to reset the TV to factory settings” (page 16).

**When [A new TV system software update is available...] message is displayed.**

Sony strongly recommends you to update the TV software by selecting [Update Now]. These software updates improve your TV performance or add new features.

The following screen with [Updating...] will appear and the illumination LED flashes white while software is updating.

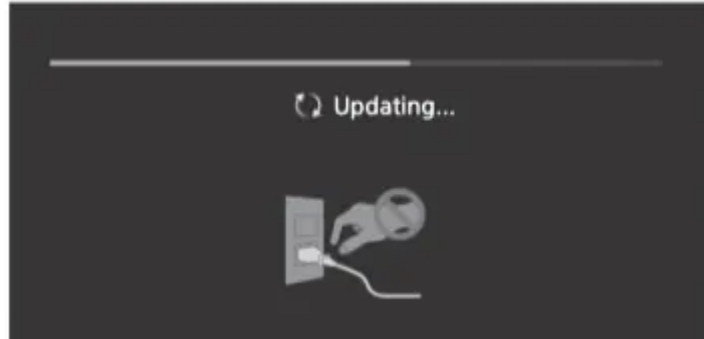

Do not unplug the AC power cord during the software update. If you do, the software update may not finish completely, and it may cause a software malfunction. Software updates can take up to 15 minutes.

**When you plug in the TV, the TV may not be able to turn on for a while even if you press the power button on the remote control or the TV.**

It takes time to initialize the system. Wait for about one minute, then operate it again.

### How to reset the TV to factory settings

**WARNING:** The reset will clear all of your customized settings including the parental lock setting.

- Turn on the TV. You can reset the TV to factory settings by pressing HOME, then select [Settings] → [Storage & reset] → [Factory data reset].
- To force factory data reset, unplug the AC power cord. Press and hold both  and buttons on the TV, then plug in the AC power cord. Release both buttons when the illumination LED blinks in green.
- For security purposes, be sure to remove all personal and account information before discarding, selling or passing your TV to someone else by: unlinking/ unregistering, signing out of and deactivating all network services as well as factory reset the TV.

## Troubles and Solutions

**When the illumination LED is flashing in red.**

- Count how many times it flashes (interval time is three seconds).

Reboot the TV by disconnecting the AC power cord from the TV for two minutes, then turn on the TV.

If the problem persists, disconnect the AC power cord, and contact Sony Customer Support (information provided on the front cover) with the number of times the illumination LED flashes.

**There is no picture (screen is dark) and no sound.**

- Check the cable/antenna connection.
- Connect the TV to the AC power, and press the power button on the TV or the remote control.

**Some programs cannot be tuned.**

- Check the cable/antenna connection.

**The remote control does not function.**

- Replace the batteries.

**The STB MENU button on the remote control does not work.**

- Check the connection and set up of the IR Blaster (page 12).

**The parental lock password has been forgotten.**

- Enter 4357 for the password and select [Change PIN].

**The restricted profile password has been forgotten.**

- Perform the force factory data reset. Refer to “How to reset the TV to factory settings” (page 16).

**The TV and its surroundings become warm.**

- When the TV is used for an extended period of time, the TV and its surroundings may become warm to the touch. This is not a malfunction of the TV.

**Warning**

This content is compiled from multiple sources and is provided for reference purposes only. It may not be complete or fully applicable to all situations. If you are unable to resolve your issue, please contact the product manufacturer or an authorized service provider for official support.