

PARTS AND FEATURES

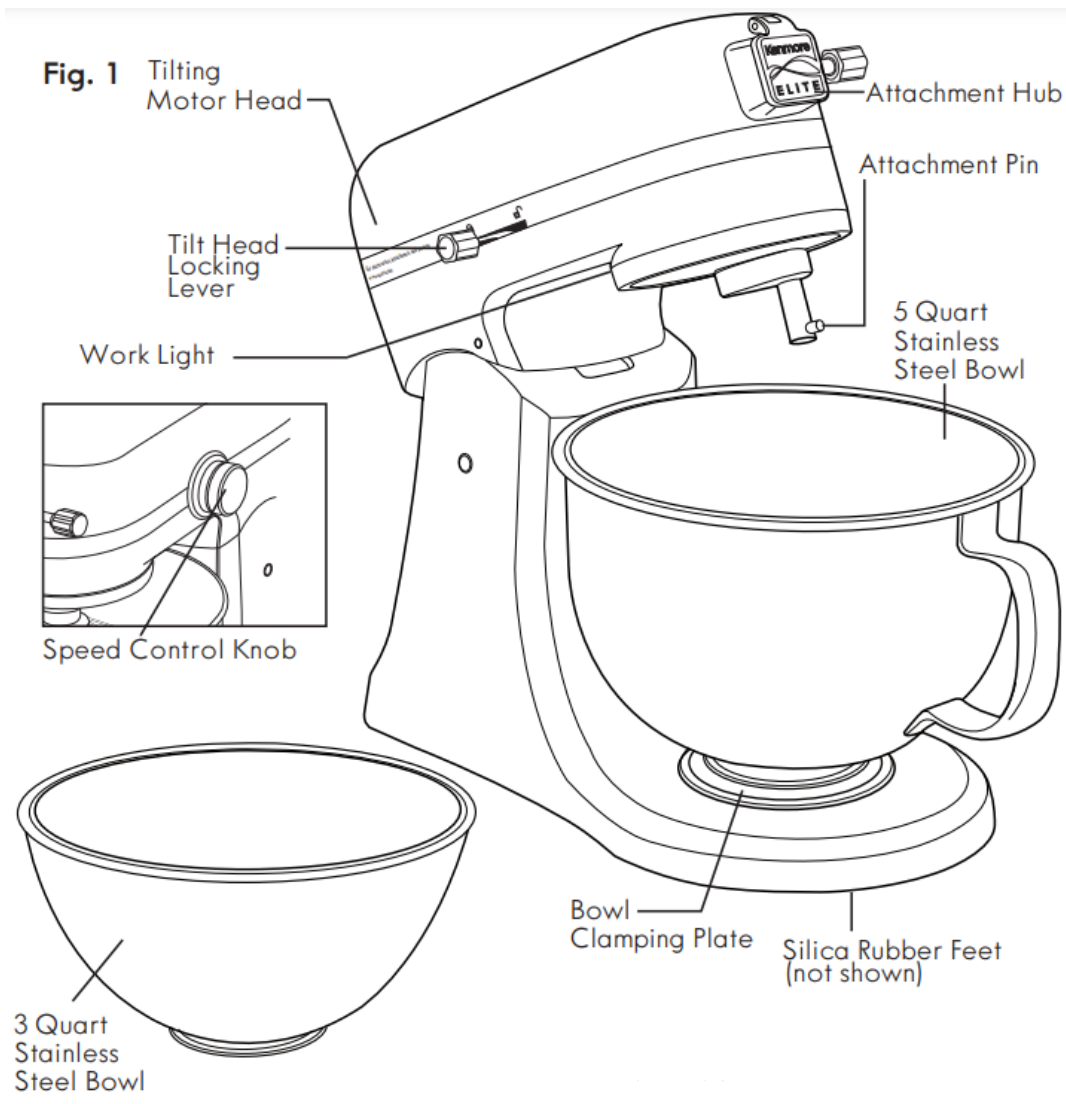

Coated Flat Beater

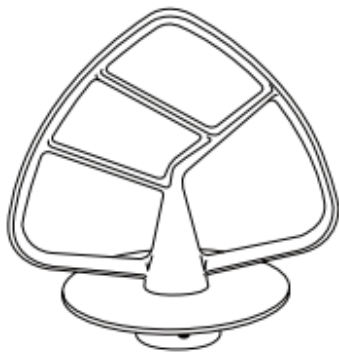

Wire Whip

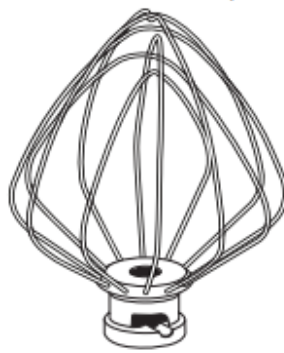

Coated Dough Hook



PREPARING TO USE YOUR STAND MIXER



BEFORE FIRST USE:

1. Before using your Stand Mixer, remove all packing material, plastic, labels, stickers or tags that may be attached to the Mixer, Bowls or Attachments.
2. Before the first use of the Stand Mixer, wash the Flat Beater, Dough Hook, and Stainless Steel Bowls in warm, sudsy water or in the dishwasher. The Wire Whip should be washed by hand only. Rinse and Dry all thoroughly.
3. The exterior of the Stand Mixer should only be cleaned with a soft damp cloth, then dried with a soft, clean cloth.
4. Place Stand Mixer on a dry, level, stable, surface such as a countertop or table. Keep Mixer away from countertop edge. Be sure to leave plenty of room around Air Vents at the rear of Mixer.

NOTE: Do not use abrasive cleansers or scouring pads when cleaning your Stand Mixer. NEVER immerse the body of the Stand Mixer in water or any liquid.

OPERATING YOUR STAND MIXER

TILT HEAD

To insert and remove attachments and bowls, it is necessary to raise the Tilting Motor Head. To raise Head, locate the Locking lever on the left hand side. Pull lever forward to the Unlock icon . Raise head and release lever. Lever will return to Lock icon . Push head all the way back until it stops. Head is now locked in place.

To lower Head, pull lever forward to Unlock icon. Release lever and guide Head down until it locks into Mix position.

WARNING: To avoid serious injury, never turn on Mixer with Beater or other attachments connected unless the Bowl is in place.

WARNING: To avoid serious injury, keep DOHers and hands away from beater attachment hole and hinge area when raising or lowering Tilt Head.

TO ATTACH BOWLS TO MIXER (see Fig. 2)

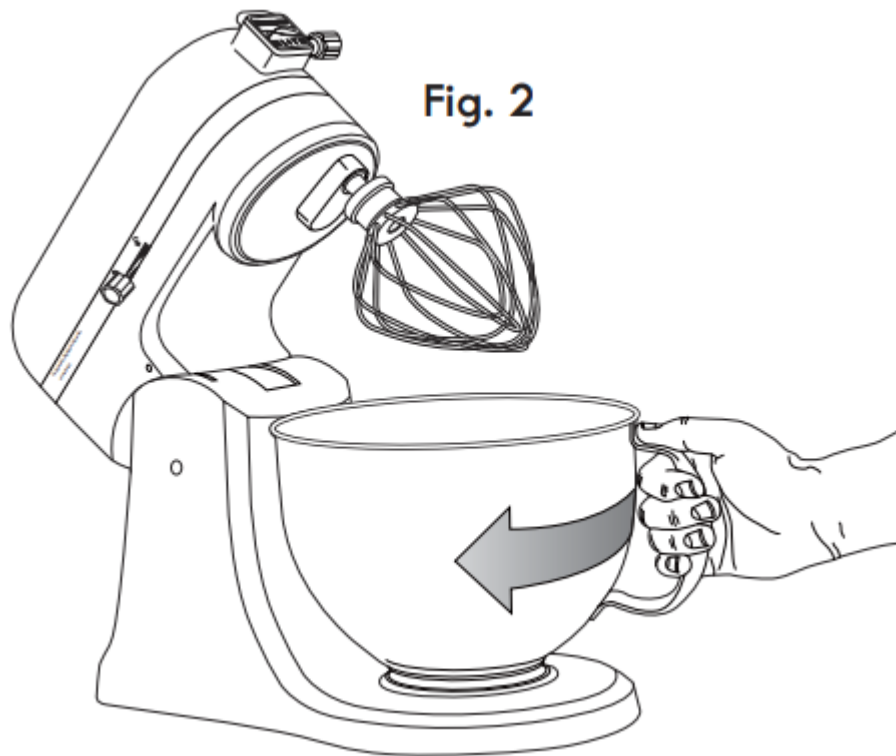

1. Turn speed control to OFF.
2. Unplug Stand mixer.
3. Tilt the Head back.
4. Place bowl in Bowl Clamping Plate.
5. Turn bowl clockwise until snug.

TO REMOVE BOWLS FROM MIXER (see Fig. 3)

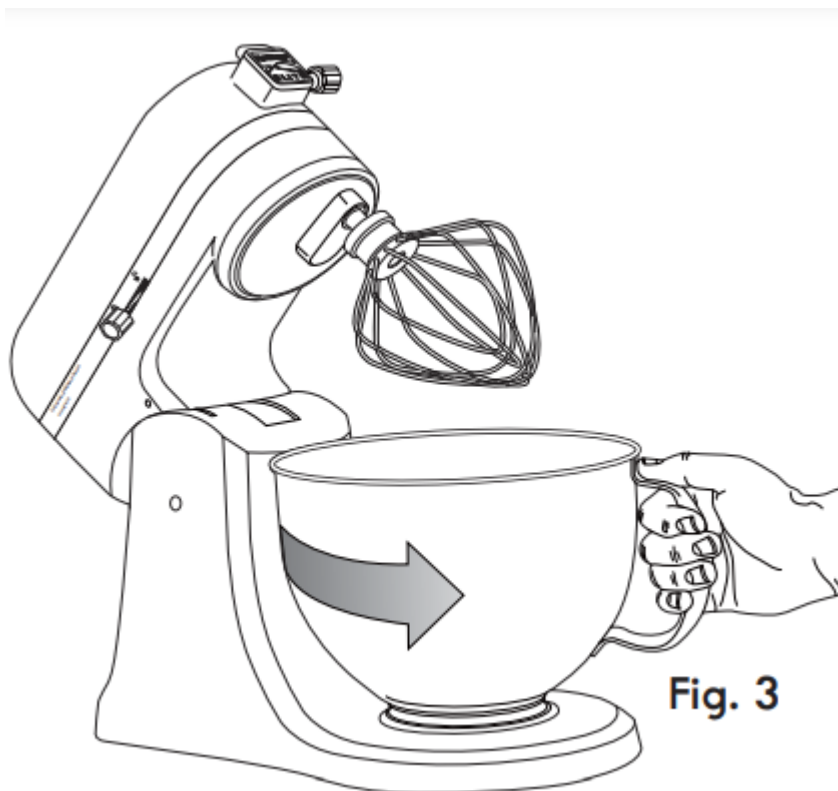

1. Turn speed control to OFF.
2. Unplug Stand mixer.
3. Tilt the Head back.
4. Turn bowl counterclockwise until loosened and pull up and out of Bowl Clamping Plate.

TO CONNECT FLAT BEATER, WIRE WHIP OR DOUGH HOOK ATTACHMENTS

1. Turn speed control to OFF.
2. Unplug Stand mixer.
3. Tilt the Head back.

4. Align slot at the top of Attachment with pin on Tilt Head shaft. Push Attachment up onto shaft and turn counterclockwise until pin moves all the way into the slot (see Fig. 4).

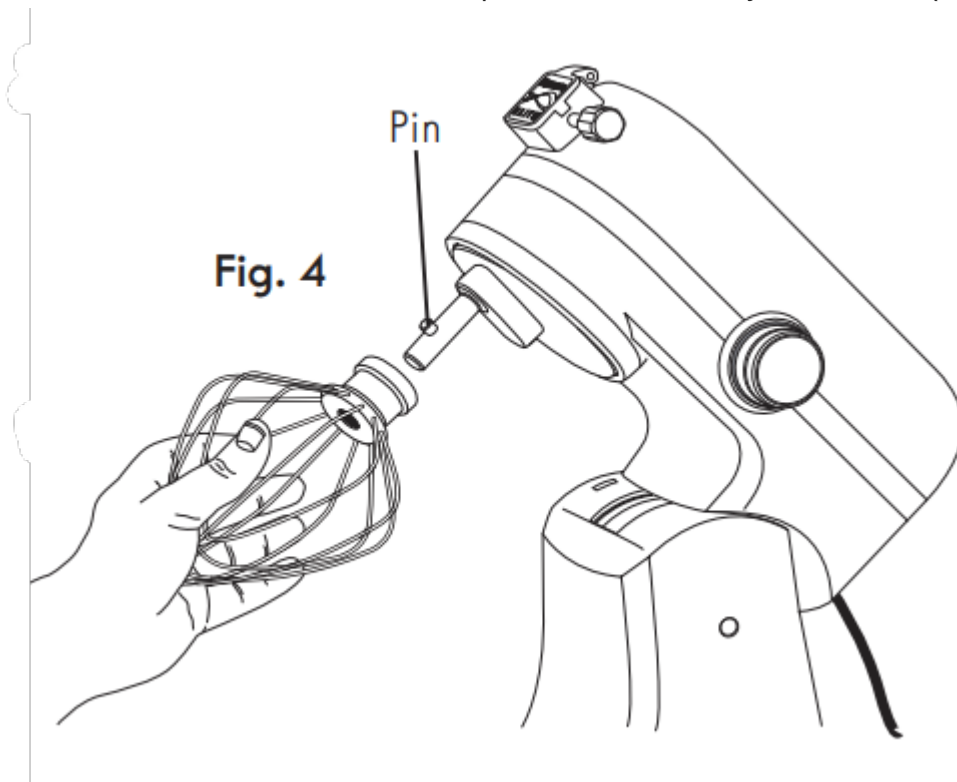

TO REMOVE FLAT BEATER, WIRE WHIP OR DOUGH HOOK

1. Turn speed control to OFF.
2. Unplug Stand mixer.
3. Tilt the Head back.
4. Turn Attachment clockwise on shaft until pin on shaft lines up with slot on attachment. Pull off.

SPEED CONTROL KNOB

The Speed Control Knob is located on the right side of the Mixer (with the front facing you), and has increments from 1 to 10 and OFF (see Fig. 5).

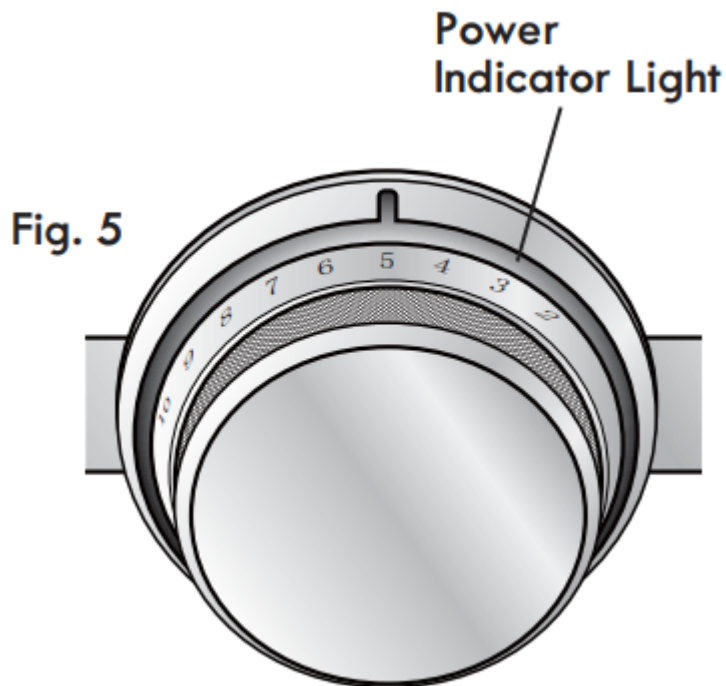

To start Mixer, turn Knob clockwise from OFF. Always start the Mixer on the slowest possible speed to avoid splashing ingredients out of the bowl.

When ingredients start to mix, turn speed up as called for in recipe. See Page 9 for Speed Control Guide.

CAUTION: To avoid unintentional starting and possible injury or product damage turn Speed Knob to OFF and unplug Stand Mixer when mixing is complete.

WORK LIGHT AND POWER INDICATOR LIGHT

When the Mixer is plugged in and a speed is selected, the blue LED light encircling the Speed Knob (see Fig. 5) comes on. A Work Light also comes on to illuminate the work area above the bowl.

When you turn the Speed Knob OFF, the blue LED Light around the Speed Knob goes out. The Work Light stays on for 3 minutes, then shuts off.

NOTE: If you plug the Mixer in with the Speed Knob turned to any speed setting, the mixer will not start, but the Speed Knob and Work Light LEDs will flash on and off. Turn the Speed Knob and Work Light LEDs will and resume normal Mixer operation.

ATTACHMENTS AND THEIR USES:



FLAT BEATER – 120V/60HZ/400W

– For normal to heavy mixtures:

- cakes
- cookies
- quick breads
- creamed frostings
- pie pastry
- meat loaf
- candies
- biscuits
- mashed potatoes



WIRE WHIP – 120V/60HZ/240W

– For mixtures that need to have air added:

- eggs
- boiled frostings
- egg whites
- sponge cakes
- heavy cream
- angel food cakes



DOUGH HOOK – 120V/60HZ/400W

– For mixing and kneading yeast doughs:

- breads
- coffee cakes
- rolls
- buns

BEATER ADJUSTMENT

The Stand Mixer is adjusted at the factory so that the Flat Beater clears the bottom of the Bowl. If the Flat Beater hits the bottom of the Bowl or is too far away from the sides, adjust as follows:

1. Turn Speed Control to OFF.
2. Unplug Stand Mixer
3. Tilt Motor Head back and lock
4. Using #3 Phillips Head screwdriver, turn screw (see Fig.6) counterclockwise (left) to raise the Flat Beater or clockwise (right) to lower.

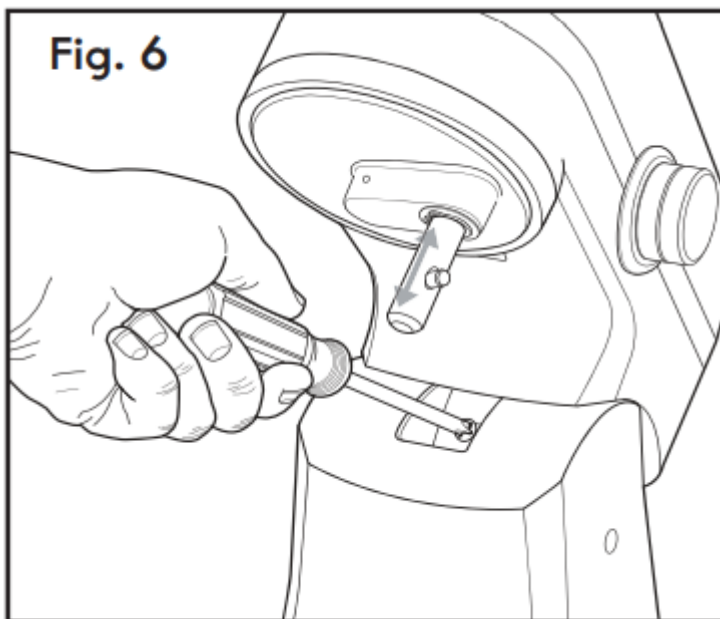

5. Adjust so that the Flat Beater just clears the surface of the Bowl. Do not over adjust. You may not be able to lock the Motor Head when lowered.

NOTE: If the Flat Beater or Wire Whip strikes the Bowl, the finish may wear off.

MIXING TIME

Your Stand Mixer will mix faster and more thoroughly than most other electric Mixers. Therefore, the mixing time in most traditional and non-packaged recipes should be adjusted to avoid overbeating. Cakes, for example, may need only half as much beating time as with other mixers.

SPEED CONTROL GUIDE

Number on Speed Knob

1	Stir	For slow stirring, combining, mashing, starting all mixing procedures. Use to add flour and dry ingredients to batter, add liquids to dry ingredients, and combine heavy mixtures. Use with Ice Cream Maker Attachment, sold separately.
2	Slow Mixing	For slow mixing, mashing, faster stirring. Use to mix heavy batters and candies, start mashing potatoes or other vegetables, cut shortening into flour, mix thin or splashy batters, and mix and knead yeast dough. Use with Can Opener Attachment, sold separately. Do not exceed Speed 2 when preparing yeast dough. This could damage the Mixer
4	Mixing, Beating	For mixing semi-heavy batter, such as cookies. Use to combine sugar and shortening and to add sugar to egg whites for meringues. Use this Medium Speed for cake mixes. Use with Food Grinder, Rotor Slicer/Shredder, and Fruit/ Vegetable Strainer, sold separately.
6	Beating, Creaming	For medium fast beating (creaming) or whipping. Use to mix cake, doughnut, and other batters. High speed for cake mixes. Use with Citrus Juicer attachment, sold separately.
8	Fast Beating, Whipping	For whipping cream, egg whites, and boiled frostings.
10	Fast Whipping	For whipping small amounts of cream or egg whites. Use with Pasta Maker and Grain Mill attachments, sold separately

NOTE: Do not scrape the bowl while the Stand Mixer is operating. The bowl and beater are designed to provide thorough mixing without frequent scraping. Scraping the bowl once or twice during mixing is usually sufficient. Turn the Mixer OFF before scraping.

NOTE: Mixer may not maintain fast speeds under heavy load. This is normal. To avoid mixer slowing down, never add more than 10 cups of flour to the mixing bowl.

MIXER TIPS AND TECHNIQUES

To help determine the ideal mixing time for a recipe, observe the batter or dough and mix only until it has the desired appearance described in your recipe, such as “smooth and creamy”.

Always add ingredients as close to the side of the bowl as possible, not directly into the moving beater.

When adding Nuts, Raisins or Candied Fruits, follow individual recipes for guidelines on including these ingredients. In general, solid materials should be folded in during the last few seconds of mixing on Speed 1. The batter should be thick enough to prevent the fruit or nuts from sinking to the bottom of the pan during baking. Sticky fruits should be dusted with flour for better distribution in the batter.

Mixtures containing large amounts of liquid ingredients should be mixed at lower speeds to avoid splashing. Increase mixer speed only after the mixture has thickened.

CARE AND CLEANING

WARNING: Injury Hazard: Unplug mixer before touching beaters or other accessories. Failure to do so can result in broken bones, cuts or bruises.

Always unplug Stand Mixer before cleaning. Do not immerse Mixer in water. The exterior of the Mixer should only be cleaned with a soft damp cloth.

NOTE: Do not use abrasive cleansers or scouring pads when cleaning your Stand Mixer. NEVER immerse the body of the Stand Mixer in water or any liquid.

Always remove attachments from Mixer before cleaning. Wash all attachments by hand or in dishwasher except Wire Whip, which should only be hand washed. Rinse and dry completely.

Beaters, Attachments and Bowls should be washed as soon as possible after use to keep food from drying on them.

Any other servicing should be performed by a qualified service dealer.

ATTACHMENTS

ATTACHMENT HUB

Your Stand Mixer comes with a built-in multipurpose Attachment Hub located in the front of the Tilt Motor Head. A leading brandname appliance maker offers a diverse selection of food preparation attachments that will connect to the Hub, and are fully functional with this Kenmore Elite Stand Mixer.

Read and carefully follow the instructions that come with the attachment for correct and safe use.

IMPORTANT SAFEGUARDS

When using electrical appliances, basic safety precautions should always be followed, including the following:

1. READ all instructions. KEEP these instructions for future use.
1. To protect against fire, electric shock and injury to persons. DO NOT immerse cord, plug, or the Stand Mixer in water or other liquids.
2. Close supervision is necessary when any appliance is used by or near children.
3. UNPLUG Stand Mixer from outlet when not in use before putting on or taking off parts and before cleaning.
4. Avoid contacting moving parts. Keep hands, hair, clothing, as well as spatulas and other utensils away from beater during operation to reduce the risk of injury to persons and/or damage to the Mixer.
5. DO NOT operate any appliance with a damaged cord or plug, or after the appliance malfunctions or has been dropped or damaged in any manner. Take the appliance to a qualified service dealer for repair.
6. The use of accessory attachments not recommended by the appliance manufacturer may result in fire, electric shock or injury to persons.
7. DO NOT use outdoors.
8. NEVER let the cord hang over the edge of table or counter, or touch hot surfaces.
9. Remove mixing bowl and flat beater, wire whip or dough hook from Stand Mixer before washing them.
10. DO NOT use this appliance for anything other than its intended use.
11. To protect against electrical shock, this appliance is equipped with a cord having 3-prong grounding-type plug for insertion into a proper grounding-type receptacle. DO NOT alter the plug for use in a 2-prong receptacle. If the plug will not fit into a receptacle, have the proper receptacle installed by a qualified electrician.
12. **This product is designed for household use only.**

13. A short power supply cord (or detachable power supply cord) is to be provided to reduce risks resulting from becoming entangled in or tripping over a longer cord. This unit is equipped with a proper cord.
1. This appliance is not intended for use by persons (including children) with reduced physical sensory or capabilities ,or lack of experience and knowledge, unless they have been given supervision or instruction concerning use of the appliance by a person responsible for their safety

Warning

This content is compiled from multiple sources and is provided for reference purposes only. It may not be complete or fully applicable to all situations. If you are unable to resolve your issue, please contact the product manufacturer or an authorized service provider for official support.

