

Maintenance

Cleaning

Clean the oven regularly to prevent impurities from building up on or inside the oven. Also pay special attention to the door, door sealing, and turntable and roller ring (applicable models only). If the door won't open or close smoothly, first check if the door seals have built up impurities. Use a soft cloth in soapy water to clean both the inner and outer sides of the oven. Rinse and dry well.

To remove stubborn impurities with bad smells from inside the oven

1. With an empty oven, put a cup of diluted lemon juice on the centre of the turntable.
2. Heat the oven for 10 minutes at max power.
3. When the cycle is complete, wait until the oven cools down. Then, open the door and clean the cooking chamber.

To clean inside swing-heater models

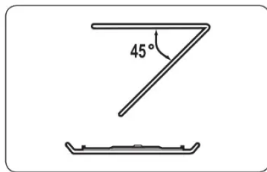

To clean the upper area of the cooking chamber, lower the top heating element by as shown. This will help clean the upper area. When done, reposition the top heating element.

CAUTION

- Keep the door and door sealing clean and ensure the door opens and closes smoothly. Otherwise, the oven's lifecycle may be shortened.
- Take caution not to spill water into the oven vents.
- Do not use any abrasive or chemical substances for cleaning.
- After each use of the oven, use a mild detergent to clean the cooking chamber after waiting for the oven to cool down.

Replacement (repair)

WARNING

- This oven has no user-removable parts inside. Do not try to replace or repair the oven yourself.

- If you encounter a problem with hinges, sealing, and/or the door, contact a qualified technician or a local Samsung service centre for technical assistance.
- If you want to replace the light bulb, contact a local Samsung service centre. Do not replace it yourself.
- If you encounter a problem with the outer housing of the oven, first unplug the power cord from the power source, and then contact a local Samsung service centre.

Care against an extended period of disuse

If you don't use the oven for an extended period of time, unplug the power cord and move the oven to a dry, dust-free location. Dust and moisture that builds up inside the oven may affect the performance of the oven.

Oven features

Oven

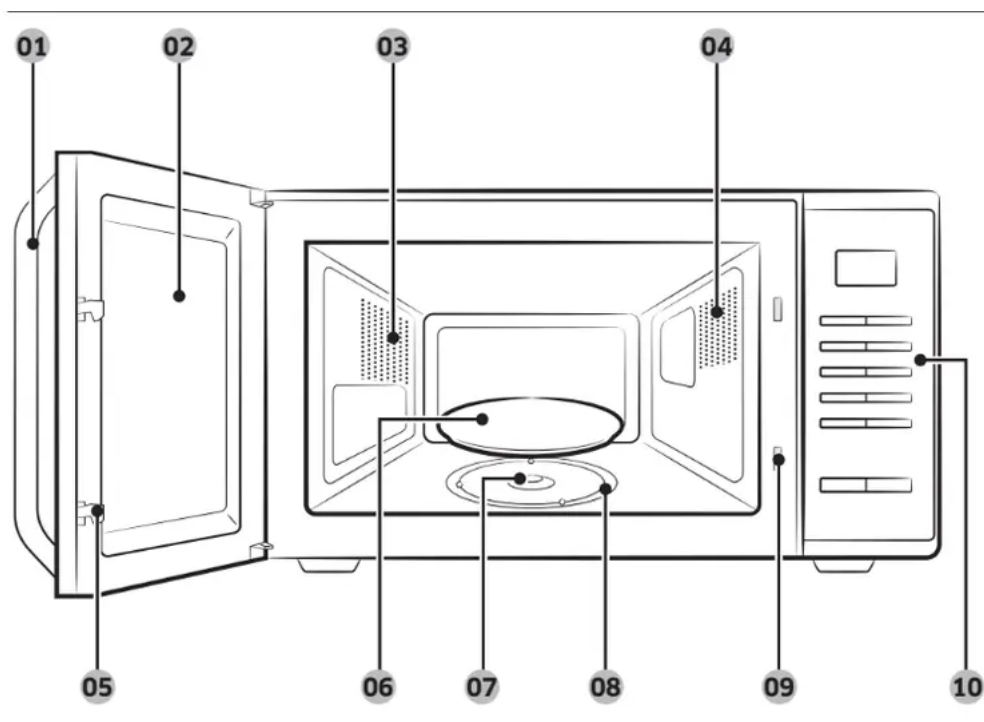

01 Door handle

02 Door

03 Ventilation holes

04 Light

05 Door latches

06 Turntable

07 Coupler

08 Roller ring

09 Safety interlock holes

10 Control panel

Control panel

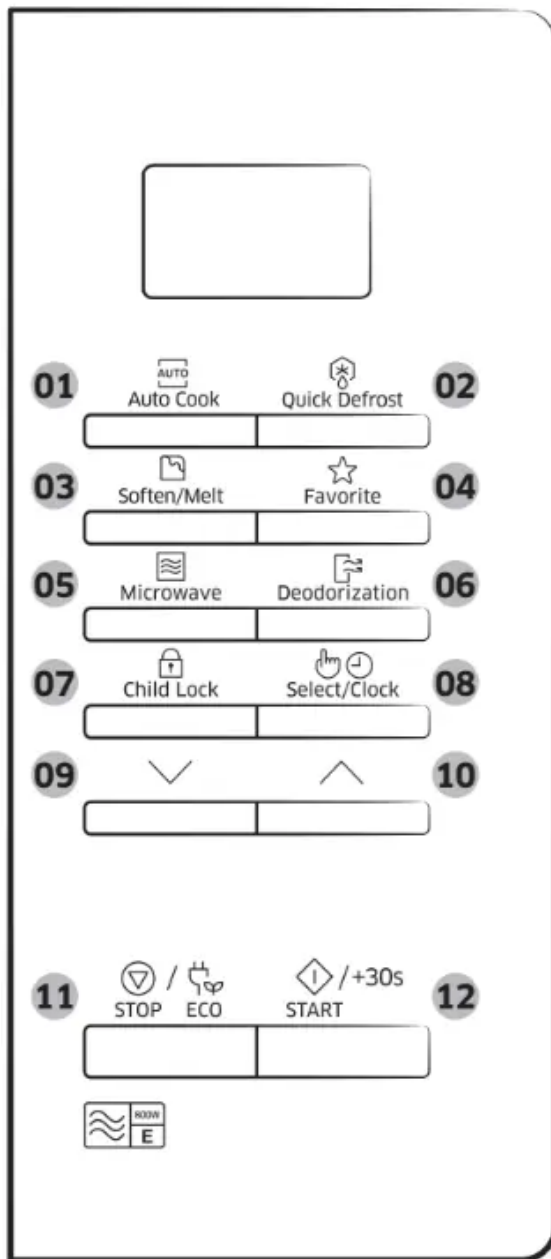

- 01 Auto Cook Button
- 02 Quick Defrost Button
- 03 Soften/Melt Button
- 04 Favorite Button
- 05 Microwave Button
- 06 Deodorization Button
- 07 Child Lock Button
- 08 Select/Clock Button
- 09 Down Button
- 10 Up Button
- 11 Stop/Eco Button
- 12 Start/+30s Button

Oven use

How a microwave oven works

Microwaves are high-frequency electromagnetic waves; the energy released enables food to be cooked or reheated without changing either the form or the colour.

You can use your microwave oven to:

- Defrost
- Reheat

- Cook

Cooking principle.

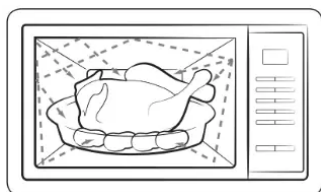

1. The microwaves generated by the magnetron reflected at cavity and are distributed uniformly as the food rotates on the turntable. The food is thus cooked evenly.

2. The microwaves are absorbed by the food up to a depth of about 1 inch (cm). Cooking then continues as the heat is dissipated within the food.

3. Cooking times vary according to the container used and the properties of the food:

1. Quantity and density
2. Water content
3. Initial temperature (refrigerated or not)

IMPORTANT

As the centre of the food is cooked by heat dissipation, cooking continues even when you have taken the food out of the oven. Standing times specified in recipes and in this booklet must therefore be respected to ensure:

- Even cooking of the food right to the centre.
- The same temperature throughout the food.

Checking that your oven is operating correctly

The following simple procedure enables you to check that your oven is working correctly at all times. If you are in doubt, refer to the section entitled "Troubleshooting" on the pages 23 to 25.

NOTE

The oven must be plugged into an appropriate wall socket. The turntable must be in position in the oven. If a power level other than the maximum (100 % - 800 W) is used, the water takes longer to boil.

Open the oven door by pulling the handle on the upper side of the door. Place a glass of water on the turntable. Close the door.



Press the START/+30s button and set the time to 4 or 5 minutes, by pressing the START/+30s button the appropriate number of times.

Result: The oven heats the water for 4 or 5 minutes. The water should then be boiling.

Cooking/Reheating

The following procedure explains how to cook or reheat food.

IMPORTANT: ALWAYS check your cooking settings before leaving the oven unattended.

Open the door. Place the food in the centre of the turntable. Close the door. Never switch the microwave oven on when it is empty.



1. Press the Microwave button.

Result: The 800 W (Maximum cooking power) indications are displayed:  microwave mode)

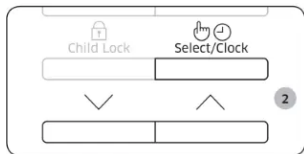

2. Select the appropriate power level by pressing the Up or Down button. (Refer to the power level table.) And then press the Select/Clock button.



3. Set the cooking time by pressing the Up or Down button.

Result: The cooking time is displayed.

4. Press the START/+30s button.

Result: The oven light comes on and the turntable starts rotating. Cooking starts and when it has finished.

1. The oven beeps 4 times.
2. The end reminder signal will beep 3 times (once every minute).
3. The current time is displayed again.



Setting the time

When power is supplied, “88:88” and then “12:00” is automatically displayed on the display.

Please set the current time. The time can be displayed in either the 24-hour or 12-hour notation. You must set the clock:

- When you first install your microwave oven
- After a power failure

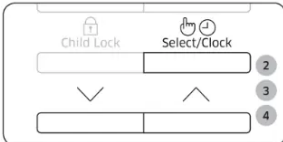
NOTE: Do not forget to reset the clock when you switch to and from summer and winter time.

| | |
|---|--|
|  | <p>1. Press the Select/Clock button.</p> |
|  | <p>2. Set the 24-hour or 12-hour notation by pressing the Up or Down button. And then press the Select/Clock button.</p> <p>3. Press the Up or Down button to set the hour. And then press the Select/Clock button.</p> <p>4. Press the Up or Down button to set the minute.</p> |
|  | <p>5. When the right time is displayed, press the Select/Clock button to start the clock.</p> <p>Result: The time is displayed whenever you are not using the microwave oven.</p> |

Power levels and time variations

The power level function enables you to adapt the amount of energy dissipated and thus the time required to cook or reheat your food, according to its type and quantity. You can choose between six power levels.

| Power level | Percentage | Output |
|-------------|------------|--------|
| HIGH | 100 % | 800 W |
| MEDIUM HIGH | 75 % | 600 W |
| MEDIUM | 56 % | 450 W |
| MEDIUM LOW | 38 % | 300 W |
| DEFROST | 23 % | 180 W |
| LOW | 13 % | 100 W |

The cooking times given in recipes and in this booklet correspond to the specific power level indicated.

| If you select a... | Then the cooking time must be... |
|--------------------|----------------------------------|
| Higher power level | Decreased |
| Lower power level | Increased |

Adjusting the cooking time

You can increase the cooking time by pressing the START/+30s button once for each 30 seconds to be added.

- Check how cooking is progressing at any time simply by opening the door
- Increase the remaining cooking time

| | |
|---|---|
|  | <p>Method 1</p> <p>To increase the cooking time of your food during cooking, press the START/+30s button once for each 30 seconds that you wish to add.</p> <ul style="list-style-type: none"> • Example: To add three minutes, press the START/+30s button six times. <p>Method 2</p> <p>Just pressing the Up or Down button to adjust cooking time</p> |
|---|---|

Stopping the cooking

You can stop cooking at any time so that you can:

- Check the food
- Turn the food over or stir it
- Leave it to stand

| To stop the cooking... | Then... |
|------------------------|---|
| Temporarily | Open the door or press the STOP/ECO button once. Result: Cooking stops. To resume cooking, close the door again and press the START/+30s button. |
| Completely | Press the STOP/ECO button once. Result: Cooking stops. If you wish to cancel the cooking settings, press the STOP/ECO button again. |

Setting the energy save mode

The oven has an energy save mode.

| | |
|--|--|
|  <p>The diagram shows a section of the oven's control panel. It features three buttons: a 'STOP' button with a power-off symbol, an 'ECO' button with a leaf symbol, and a 'START' button with a diamond symbol and '+30s' text. Below these buttons is a digital display area.</p> | <p>Press the STOP/ECO button.</p> <p>Result: Display off.</p> <p>To remove energy save mode, open the door or press the STOP/ECO button and then display shows current time. The oven is ready for use.</p> |
|--|--|

NOTE

Auto energy saving function

If you do not select any function when appliance is in the middle of setting or operating with temporary stop condition, function is canceled and clock will be displayed after 25 minutes. Oven Lamp will be turned off after 5 minutes with door open condition.



Using the auto cook features

The Auto Cook features has 20 pre-programmed cooking times. You do not need to set either the cooking times or the power level.

You can adjust the type of the serving by pressing the Up or Down button.

IMPORTANT: Use only recipients that are microwave-safe.

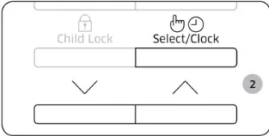
First, place the food in the centre of the turntable and close the door.

| | |
|---|---|
|  | <p>1. Press the Auto Cook button.</p> |
|  | <p>2. Select the type of food that you are cooking by pressing the Up or Down button. And then press the Select/Clock button.</p> |
|  | <p>3. Press the START/+30s button.</p> <p>Result: The food is cooked according to the pre-programmed setting selected.</p> <ul style="list-style-type: none"> • The oven beeps 4 times. • The end reminder signal will beep times (once every minute). • The current time is displayed again. |

| Code/Food | Serving size | Instructions |
|------------------------------|--------------|--|
| 1 Chilled Ready Meal | 300-350 g | Put on a ceramic plate and cover with microwave cling film. This programme is suitable for meals consisting of 3 components (e.g. meat with sauce, vegetables and a side dishes like potatoes, rice or pasta). Stand for 2-3 minutes. |
| 2 Chilled Ready Meal | 400-450 g | |
| 3 Chilled Vegetarian Meal | 300-350 g | Put meal on a ceramic plate and cover with microwave cling film. This programme is suitable for meals consisting of 2 components (e.g. spaghetti with sauce or rice with vegetables). Stand for 2-3 minutes. |
| 4 Chilled Vegetarian Meal | 400-450 g | |
| 5 Broccoli | 250 g | Rinse and clean fresh broccoli and prepare florets. Put them evenly into a glass bowl with lid. Add 30 ml (2 tbsp) water when cooking for 250 g. Put bowl in the centre of turntable. Cook covered. Stir after cooking. Stand for 1-2 minutes. |
| 6 Carrots | 250 g | Rinse and clean carrots and prepare even slices. Put them evenly into a glass bowl with lid. Add 30 ml (2 tbsp) water when cooking for 250 g. Put bowl in the centre of turntable. Cook covered. Stir after cooking. Stand for 1-2 minutes. |
| 7 Green Beans | 250 g | Rinse and clean green beans. Put them evenly into a glass bowl with lid. Add 30 ml (2 tbsp) water when cooking 250 g. Put bowl in the centre of turntable. Cook covered. |

| Code/Food | Serving size | Instructions |
|--------------------------|--------------|--|
| 8 Spinach | 150 g | Rinse and clean spinach. Put into a glass bowl with lid. Do not add water. Put bowl in the centre of turntable. Cook covered. Stir after cooking. Stand for 1-2 minutes. |
| 9 Corn on the Cob | 250 g | Rinse and clean corn on the cob and put into an oval glass dish. Cover with microwave cling film and pierce film. Stand for 1-2 minutes. |
| 10 Peeled Potatoes | 250 g | Wash and peel the potatoes and cut into a similar size. Put them into a glass bowl with lid. Add 45-60 ml (3-4 tbsp) water. Put bowl in the centre of turntable. Cook covered. Stand for 2-3 minutes. |
| 11 Brown Rice | 125 g | Use a large glass ovenware dish with lid. Add double quantity of cold water (250 ml). Cook covered. Stir before standing time and add salt and herbs. Stand for 5-10 minutes. |
| 12 Wholemeal Macaroni | 125 g | Use a large glass ovenware dish with lid. Add 500 ml hot boiling water, a pinch of salt and stir well. Cook uncovered. Stir before standing time and drain thoroughly afterwards. Stand for 1 minutes. |
| 13 Quinoa | 125 g | Use a large glass ovenware dish with lid. Add double quantity of cold water (250 ml). Cook covered. Stir before standing time and add salt and herbs. Stand for 1-3 minutes. |
| 14 Bulgur | 125 g | Use a large glass ovenware dish with lid. Add double quantity of cold water (250 ml). Cook covered. Stir before standing time and add salt and herbs. Stand for 2-5 minutes. |

| Code/Food | Serving size | Instructions |
|----------------------------|--------------|--|
| 15 Chicken Breasts | 300 g | Rinse pieces and put on a ceramic plate. Cover with microwave cling film. Pierce film. Put dish on turntable. Stand for 2 minutes. |
| 16 Turkey Breasts | 300 g | Rinse pieces and put on a ceramic plate. Cover with microwave cling film. Pierce film. Put dish on turntable. Stand for 2 minutes. |
| 17 Fresh Fish Fillets | 300 g | Rinse fish and put on a ceramic plate, add 1 tbsp lemon juice. Cover with microwave cling film. Pierce film. Put dish on turntable. Stand for 1-2 minutes. |
| 18 Fresh Salmon Fillets | 300 g | Rinse fish and put on a ceramic plate, add 1 tbsp lemon juice. Cover with microwave cling film. Pierce film. Put dish on turntable. Stand for 1-2 minutes. |
| 19 Fresh Prawns | 250 g | Rinse prawns on a ceramic plate, add 1 tbsp lemon juice. Cover with microwave cling film. Pierce film. Put dish on turntable. Stand for 1-2 minutes. |
| 20 Fresh Trout | 200 g | Put 1 fresh whole fish into an ovenproof dish. Add a pinch salt, 1 tbsp lemon juice and herbs. Cover with microwave cling film. Pierce film. Put dish on turntable. Stand for 2 minutes. |



Using the quick defrost features

The Quick Defrost features enable you to defrost meat, poultry, fish, frozen vegetable and frozen bread. The defrost time and power level are set automatically. You simply select the programme and the weight.

NOTE

Use only containers that are microwave-safe.

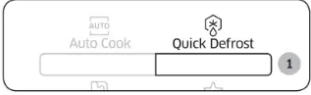
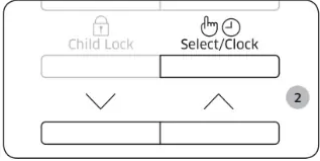
Open the door. Place the frozen food on a ceramic in the centre of the turntable. Close the door.

| | |
|---|---|
|  | <p>1. Press the Quick Defrost button.</p> |
|  | <p>2. Select the type of food that you are cooking by pressing the Up or Down button. And then press the Select/Clock button.</p> |
|  | <p>3. Select the size of the serving by pressing the Up or Down button. (Refer to the table on the side.)</p> <p>4. Press the START/+30s button.</p> <p>Result:</p> <ul style="list-style-type: none"> • Defrosting begins. • The oven beeps through defrosting to remind you to turn the food over. <p>5. Press the START/+30s button again to finish defrosting.</p> <p>Result:</p> <ul style="list-style-type: none"> • The oven beeps 4 times. • The end reminder signal will beep 3 times (once every minute). • The current time is displayed again. |

The following table presents the various Quick Defrost programmes, serving size, standing times and appropriate instructions. Remove all kind of package material before defrosting. Place meat, poultry, fish, vegetable and bread on a flat glass dish or ceramic plate.



| Code/Food | Serving size | Instructions |
|----------------|--------------|---|
| 1 Meat | 200-1500 g | Shield the edges with aluminium foil. Turn the meat over, when the oven beeps. This programme is suitable for beef, lamb, pork, steaks, chops, minced meat. Stand for 20-60 minutes. |
| 2 Poultry | 200-1500 g | Shield the leg and wing tips with aluminium foil. Turn the poultry over, when the oven beeps. This programme is suitable for whole chicken as well as for chicken portions. Stand for 20-60 minutes. |
| 3 Fish | 200-1500 g | Shield the tail of a whole fish with aluminium foil. Turn the fish over, when the oven beeps. This programme is suitable for whole fishes as well as for fish fillets. Stand for 20-60 minutes. |
| 4 Vegetable | 200-1500 g | Spread frozen vegetable evenly into a flat glass dish. Turn over or stir the frozen vegetable, when the oven beeps. This programme is suitable for all kind of frozen vegetable. Stand for 5-20 minutes. |
| 5 Bread | 200-1500 g | Put bread horizontally on a piece of kitchen paper and turn over, as soon as the oven beeps. Place cake on a ceramic plate and if possible, turn over, as soon as the oven beeps. (Oven keeps operating and is stopped, when you open the door.) This programme is suitable for all kinds of bread, sliced or whole, as well as for bread rolls and baguettes. Arrange bread rolls in a circle. This programme is suitable for all kinds of yeast cake, biscuit, cheese cake and puff pastry. It is not suitable for short/ crust pastry, fruit and cream cakes as well as for cake with chocolate topping. Stand for 10- 30 minutes. |

Using the soften/melt features

The Soften/Melt features has 4 pre-programmed cooking times. You do not need to set either the cooking times or the power level. You can adjust the number of servings by pressing the Up or Down button.

First, place the food in the centre of the turntable and close the door.

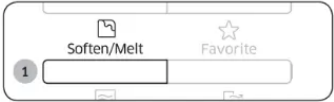
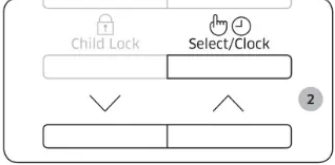
NOTE: Use only containers that are microwave safe.

| | |
|---|---|
|  | <p>1. Press the Soften/Melt button.</p> |
|  | <p>2. Select the type of food that you are cooking by pressing the Up or Down button. And then press the Select/Clock button.</p> |
|  | <p>3. Select the size of the serving by pressing the Up or Down button. (Refer to the table on the side.)</p> <p>4. Press the START/+30s button.</p> <p>Result: The food is cooked according to the preprogrammed setting selected.</p> <ol style="list-style-type: none"> 1. The oven beeps 4 times. 2. The end reminder signal will beep 3 times (once every minute). 3. The current time is displayed again. |

The following table presents the Soften/Melt programmes, quantities and appropriate instructions. Those programmes are running with microwave energy only.

| Code/Food | Serving Size | Instructions |
|--------------------------|---------------|--|
| 1 Melt Butter | 50 g 100 g | Cut butter into 3 or 4 pieces and Put them on small glass bowl. Melt uncovered. Stir after cooking. Stand for 1-2 minutes. |
| 2 Melt Dark Chocolate | 50 g 100 g | Grate dark chocolate and put in small glass bowl. Melt uncovered. Stir after melting. Stand for 1-2 minutes. |
| 3 Melt Sugar | 25 g 50 g | Put sugar on small glass bowl. Add 10 ml water for 25 g and add 20 ml water for 50 g. Melt uncovered. Take out carefully, use oven gloves! Use spoon or fork and pour caramel decorations on baking paper. Let stand for 10 minutes until dry and remove from paper. |
| 4 Soften Butter | 50 g 100 g | Cut butter into 3 or 4 pieces and Put them in small glass bowl. Soften uncovered. Stand for 1-2 minutes. |

Using the favorite features

If you often cook or reheat the same types of dishes, you can store the cooking times and power levels in the oven's memory, so that you do not have to reset them each order.

You can store two different setting.

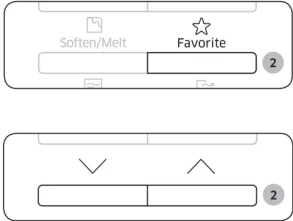
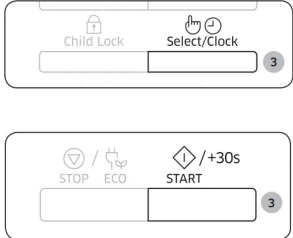
| | |
|---|--|
|  <p>The diagram shows two panels of the oven control interface. The top panel has a 'Soften/Melt' button on the left and a 'Favorite' button with a star icon on the right. Below the 'Favorite' button is a digital display showing '00:00' and a small '2' in a circle. The bottom panel has a downward arrow button on the left and an upward arrow button on the right. Below these arrows is a digital display showing '00:00' and a small '2' in a circle.</p> | <p>1. Set your cooking programme as usual cooking time and power level) see Cooking/Reheating page again if necessary.</p> <p>2. Press Favorite button, then select the program that you want to save by pressing the Up or Down button.</p> <p>P1 : First setting P2 : Second setting</p> |
|  <p>The diagram shows two panels of the oven control interface. The top panel has a 'Child Lock' button with a padlock icon on the left and a 'Select/Clock' button with a hand icon and a clock icon on the right. Below the 'Select/Clock' button is a digital display showing '00:00' and a small '3' in a circle. The bottom panel has a 'STOP' button with a square icon, an 'ECO' button with a leaf icon, and a 'START' button with a diamond icon and '+30s' text. Below the 'START' button is a digital display showing '00:00' and a small '3' in a circle.</p> | <p>3. Press the Select/Clock button to finish the setting. Or, press the START/+30s button to start the program immediately.</p> <p>Result: Your setting are now stored in the oven's memory.</p> |

Information

Example : If you want to store Microwave mode, Power 600 W and 3 minutes on P1.

1. Press the Microwave button.
2. Set the power 600 W by pressing the Up or Down button. And then press the Select/ Clock button.
3. Set the cooking time 3 minutes by pressing the Up or Down button.
4. Press Favorite button, then select the P1.
5. Press the Select/Clock or START/+30s button to finish the setting.

To use the favorite setting

First, place the food in the centre of the turntable and close the door.

| | |
|--|--|
| | <p>1. Press Favorite button, then select the program by pressing the Up or Down button.</p> <p>P1 : First setting</p> <p>P2 : Second setting</p> |
| | <p>2. Press the START/+30s button.</p> <p>Result: The food is cooked as requested.</p> |

Using the deodorization features

Use this features after cooking odorous food or when there is a lot of smoke in the oven interior.

First clean the oven interior.

| | |
|--|---|
|  | <p>Press the Deodorization button after you have finished cleaning. As soon as you press the Deodorization button, the operation will start automatically. when it has finished, the oven beeps four times.</p> |
|--|---|

NOTE: The deodorization time has been specified as 5 minutes. It increases by 30 seconds whenever the START/+30s button is pressed.

NOTE: The maximum deodorization time is 15 minutes.

Using the child lock features

Your microwave oven is fitted with a special child lock programme, which enables the oven to be “locked” so that children or anyone unfamiliar with it cannot operate it accidentally.



1. Press the Child Lock button for 3 seconds.

Result:

- The oven is locked (no functions can be selected).
- The display shows “L”.



2. To unlock the oven, press the Child Lock button for 3 seconds.

Result: The oven can be used normally.

Switching the beeper off

You can switch the beeper off whenever you want.

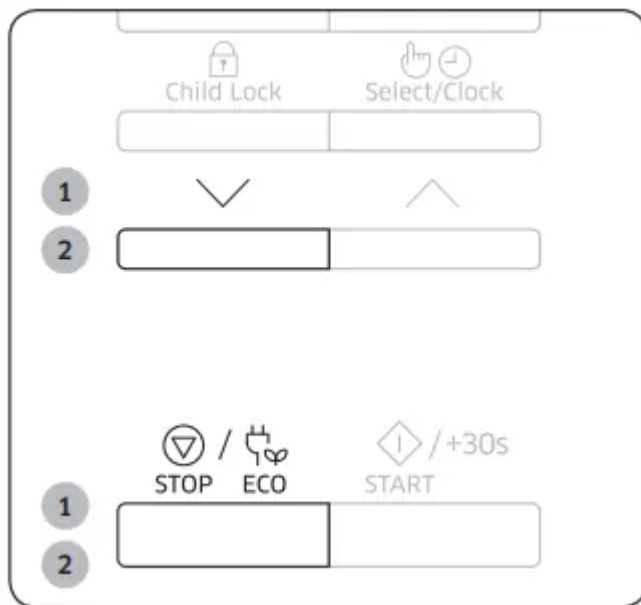

You can switch the beeper off whenever you want.

1. Press the Down and STOP/ECO button at the same time.

Result: The oven does not beep to indicate the end of a function.

2. To switch the beeper back on, press the Down and STOP/ECO button again at the same time.

Result: The oven operates normally.

Cooking guide

Microwaves

Microwave energy actually penetrates food, attracted and absorbed by its water, fat and sugar content. The microwaves cause the molecules in the food to move rapidly. The rapid movement of these molecules creates friction and the resulting heat cooks the food.

Cooking

Cookware for microwave cooking:

Cookware must allow microwave energy to pass through it for maximum efficiency. Microwaves are reflected by metal, such as stainless steel, aluminium and copper, but they can penetrate through ceramic, glass, porcelain and plastic as well as paper and wood. So food must never be cooked in metal containers.

Food suitable for microwave cooking:

Many kinds of food are suitable for microwave cooking, including fresh or frozen vegetables, fruit, pasta, rice, grains, beans, fish, and meat. Sauces, custard, soups, steamed puddings, preserves, and chutneys can also be cooked in a microwave oven. Generally speaking, microwave cooking is ideal for any food that would normally be prepared on a hob. Melting butter or chocolate, for example (see the chapter with tips, techniques and hints).

Covering during cooking

To cover the food during cooking is very important, as the evaporated water rises as steam and contributes to cooking process. Food can be covered in different ways: e.g. with a ceramic plate, plastic cover or microwave suitable cling film.

Standing times

After cooking is over food the standing time is important to allow the temperature to even out within the food.

Troubleshooting and information code

Troubleshooting

If you have any of the problems listed below try the solutions given.

| Problem | Cause | Action |
|---|--|--|
| General | | |
| The buttons cannot be pressed properly. | Foreign matter may be caught between the buttons. | Remove the foreign matter and try again. |
| | For touch models: Moisture is on the exterior. | Wipe the moisture from the exterior. |
| | Child lock is activated. | Deactivate Child lock. |
| The time is not displayed. | The Eco (power-saving) function is set. | Turn off the Eco function. |
| The oven does not work. | Power is not supplied. | Make sure power is supplied. |
| | The door is open. | Close the door and try again. |
| | The door open safety mechanisms are covered in foreign matter. | Remove the foreign matter and try again. |
| The oven stops while in operation. | The user has opened the door to turn food over. | After turning over the food, press the Start button again to start operation. |
| The power turns off during operation. | The oven has been cooking for an extended period of time. | After cooking for an extended period of time, let the oven cool. |
| | The cooling fan is not working. | Listen for the sound of the cooling fan. |
| | Trying to operate the oven without food inside. | Put food in the oven. |
| | There is not sufficient ventilation space for the oven. | There are intake/exhaust outlets on the front and rear of the oven for ventilation. Keep the gaps specified in the product installation guide. |
| | | Designate only one socket to be used for the oven. |

| | | |
|---|---|--|
| | Several power plugs are being used in the same socket. | |
| There is a popping sound during operation, and the oven doesn't work. | Cooking sealed food or using a container with a lid may causes popping sounds. | Do not use sealed containers as they may burst during cooking due to expansion of the contents. |
| The oven exterior is too hot during operation. | There is not sufficient ventilation space for the oven. | There are intake/exhaust outlets on the front and rear of the oven for ventilation. Keep the gaps specified in the product installation guide. |
| | Objects are on top of the oven. | Remove all objects on the top of the oven. |
| The door cannot be opened properly | Food residue is stuck between the door and oven interior. | Clean the oven and then open the door. |
| Heating including the Warm function does not work properly. | The oven may not work, too much food is being cooked, or improper cookware is being used. | Put one cup of water in a microwave-safe container and run the microwave for 1-2 minutes to check whether the water is heated. Reduce the amount of food and start the function again. Use a cooking container with a flat bottom. |
| The thaw function does not work. | Too much food is being cooked. | Reduce the amount of food and start the function again. |
| The interior light is dim or does not turn on. | The door has been left open for a long time. | The interior light may automatically turn off when the Eco function operates. Close and reopen the door or press the Cancel button |
| | The interior light is covered by foreign matter. | Clean the inside of the oven and check again. |
| A beeping sound occurs during cooking. | If the Auto Cook function is being used, this beeping sound means it's time to turn over the food during thawing. | After turning over the food, press the Start button again to restart operation. |

| | | |
|--|--|---|
| The oven is not level. | The oven is installed on an uneven surface. | Make sure the oven is installed on flat, stable surface. |
| There are sparks during cooking. | Metal containers are used during the oven/thawing functions. | Do not use metal containers. |
| When power is connected, the oven immediately starts to work. | The door is not properly closed. | Close the door and check again. |
| There is electricity coming from the oven. | The power or power socket is not properly grounded. | Make sure the power and power socket are properly grounded. |
| <ol style="list-style-type: none"> 1. Water drips. 2. Steam emits through a door crack. 3. Water remains in the oven. | There may be water or steam in some cases depending on the food. This is not an oven malfunction. | Let the oven cool and then wipe with a dry dish towel. |
| The brightness inside the oven varies. | Brightness changes depending on power output changes according to function. | Power output changes during cooking are not malfunctions. This is not an oven malfunction. |
| Cooking is finished, but the cooling fan is still running. | To ventilate the oven, the cooling fan continues to run for about 3 minutes after cooking is complete. | This is not an oven malfunction. |
| Turntable | | |
| While turning, the turntable comes out of place or stops turning. | There is no roller ring, or the roller ring is not properly in place. | Install the roller ring and then try again. |
| The turn table drags while turning. | The roller ring is not properly in place, there is too much food, or the | Adjust the amount of food and do not use containers that are too large. |

| | | |
|--|---|--|
| | container is too large and touches the inside of the microwave. | |
| The turn table rattles while turning and is noisy. | Food residue is stuck to the bottom of the oven. | Remove any food residue stuck to the bottom of the oven. |

Information code

| Information code | CAUSE | Action |
|------------------|--|---|
| C-d0 | Control buttons are pressed over 10 seconds. | Clean the keys and check if there is water on the surface around key. If it occurs again, turn off the microwave oven over 30 seconds and try setting again. If it appears again, call your local SAMSUNG Customer Care Centre. |

NOTE: If the suggested solution does not solve the problem, contact your local SAMSUNG Customer Care Centre.

Warning

This content is compiled from multiple sources and is provided for reference purposes only. It may not be complete or fully applicable to all situations. If you are unable to resolve your issue, please contact the product manufacturer or an authorized service provider for official support.