

FEATURES AND BENEFITS

1. Ingredient Spout

Pour recipe ingredients through the spout. Also use to add ingredients, like chips or nuts, without interrupting the freezing cycle.

2. Easy-lock Lid

Transparent to let you watch the freezing process as it progresses. Lid is designed to easily lock to the base.

3. Mixing Arm

Mixes and aerates ingredients in freezer bowl to create frozen dessert or drink.

4. Freezer Bowl

Contains cooling liquid within a double insulated wall to create fast and even freezing. Double wall keeps the bowl cool and at an even temperature.

5. Base

Contains heavy-duty motor strong enough to handle ice cream, frozen yogurt, sherbet, sorbet, and frozen drinks.

6. On/Off Dial

7. Rubber Feet (not shown)

Nonslip feet keep base stationary during use.

8. Cord Storage (not shown)

Unused cord is easily pushed into the base to keep counters neat and safe.

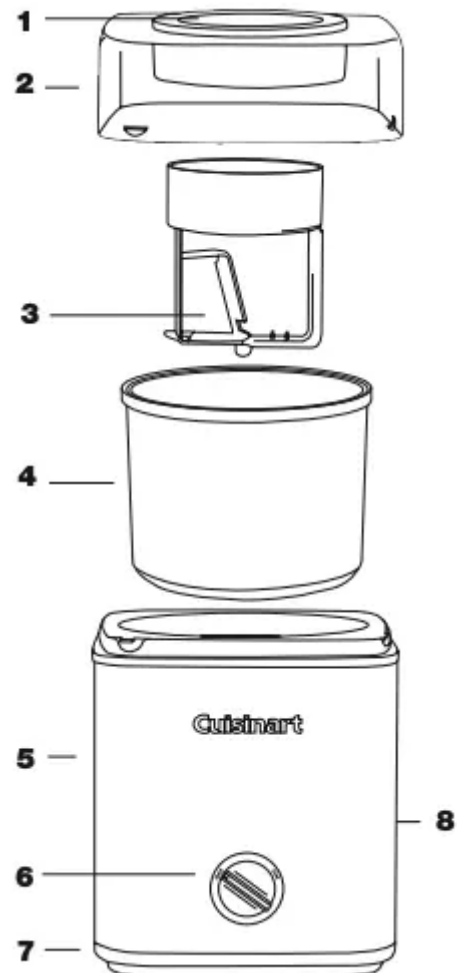

BEFORE USING FOR THE FIRST TIME

DO NOT immerse the motor base in water. Wipe it with a moist cloth. Wash the lid, freezer bowl and mixing arm in warm soapy water to remove any dust or residue from the manufacturing and shipping process. DO NOT clean any of the parts with abrasive cleaners or hard implements.

FREEZING TIME AND BOWL PREPARATION

The freezer bowl must be completely frozen before you begin your recipe. The length of time needed to reach the frozen state depends on how cold your freezer is. For the most convenient frozen desserts and drinks, leave your freezer bowl in the freezer at all times. You can take it out any time for immediate use. In general, freezing time is between 6 hours and 22 hours. To determine whether the bowl is completely frozen, shake it. If you do not hear liquid moving, the cooling liquid is frozen. Before freezing, wash and dry the bowl. Wrap it in a plastic bag to prevent freezer burn. We recommend that you place the freezer bowl in the back of your freezer where it is coldest.

Reminder: Your freezer should be set to 0°F to ensure proper freezing of all foods

MAKING FROZEN DESSERTS OR DRINKS

- 1. Use Cuisinart's recipes from the pages that follow, or use your own recipe, making sure it yields 2 quarts or less. Do not fill the freezer bowl higher than 1/2" from the top. The ingredients will increase in volume during the freezing process. For best results, prepare ingredients in a container from which it is easy to pour.
- 2. Remove the freezer bowl from the freezer. (Remove plastic bag if you have wrapped freezer bowl.) Place freezer bowl on the center of the base.

NOTE: Bowl will begin to defrost quickly once it has been removed from freezer. Use it immediately after removing from freezer.

- 3. Place mixing arm in freezer bowl. Arm does not fit tightly. It just rests in the center of the bowl, with the circle side facing up.
- 4. Place lid on base. Easy-lock lid mechanism allows lid to rest on base in multiple positions (see diagram).

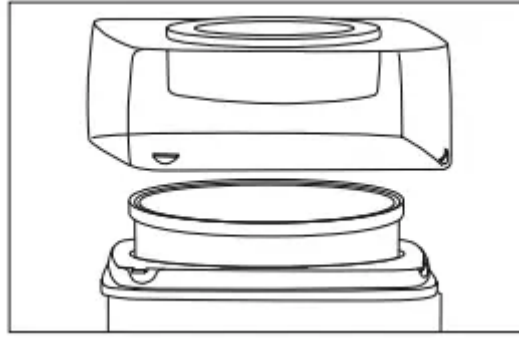

- 5. Turn the On/Off switch to ON position. Freezer bowl will begin to turn.
- 6. Immediately pour ingredients through ingredient spout.
- 7. Frozen desserts or drinks will be done in 25–35 minutes. The time will depend on the recipe and volume of the dessert or drink you are making. When the mixture has thickened to your liking, it is done. If you desire a firmer consistency, transfer the dessert or drink to an airtight container and store in the freezer for two or more hours.

NOTE: Do not store frozen desserts or drinks in the freezer bowl. Desserts and drinks will stick to the side of the freezer bowl and may damage the bowl. Store only in a plastic airtight container.

ADDING INGREDIENTS

Ingredients such as chips and nuts should be added about 5 minutes before the recipe is complete. Once the dessert or drink has begun to thicken, add the ingredients through the ingredient spout. Nuts and other ingredients should be no larger than a chocolate chip.

SAFETY FEATURE

The Cuisinart® Pure Indulgence™ Frozen Yogurt–Ice Cream & Sorbet Maker is equipped with a safety feature that automatically stops the unit if the motor overheats. This may occur if the dessert or drink is extremely thick, if the unit has been running for an excessively long period of time, or if added ingredients (nuts, etc.) are in extremely large pieces. To reset the unit, turn the ON/OFF switch to the OFF position. Let the unit cool off. After a few minutes, you may turn the unit on again and continue making the dessert or drink.

CLEANING AND STORAGE

Cleaning

Clean the freezer bowl, mixing arm and lid in warm soapy water. **DO NOT PUT FREEZER BOWL IN THE DISHWASHER. DO NOT CLEAN WITH ABRASIVE CLEANSERS OR IMPLEMENTS.**

Wipe motor base clean with damp cloth. Dry all parts thoroughly.

Storage

DO NOT put freezer bowl in freezer if bowl is wet. DO NOT store lid, mixing arm, or base in freezer. You may store the freezer bowl in the freezer for convenient, immediate use. Before freezing, wrap the bowl in a plastic bag to prevent freezer burn. Do not store frozen desserts or drinks in the freezer bowl in the freezer for more than 30 minutes at a time. Transfer frozen desserts or drinks to an airtight container for longer storage in the freezer.

IMPORTANT SAFEGUARDS

When using an electrical appliance, basic safety precautions should always be followed to reduce the risk of fire, electric shock, and/or injury, including the following:

1. READ ALL INSTRUCTIONS BEFORE USING.
2. To protect against risk of electric shock, do not place cord, plug, or base of appliance in water or any other liquid.
3. Close supervision is necessary when any appliance is used by or near children.
4. Always unplug from outlet when not in use, before putting on or taking off parts, and before cleaning.
5. Avoid contact with moving parts. Keep hands, hair, clothing, as well as spatulas and other utensils away during operation to reduce the risk of injury and/or damage to the appliance.
6. Do not operate any appliance with a damaged cord or plug, or after the appliance malfunctions, or is dropped or damaged in any manner. Return the appliance to the nearest Cuisinart Repair Center for examination, repair, electrical or mechanical adjustment.
7. The use of attachments not recommended by Cuisinart may cause fire, electric shock or risk of injuries.
8. Do not use outdoors.
9. Do not let cord hang over edge of table or counter, or touch hot surfaces.
10. Keep hands and utensils out of freezer bowl while in use to reduce the risk of injury to persons or to the appliance itself. DO NOT USE SHARP OBJECTS OR UTENSILS INSIDE THE FREEZER BOWL! Sharp objects will scratch and damage the inside of the freezer bowl. A rubber spatula or wooden spoon may be used when the appliance is in the OFF position.
11. This appliance is for household use. Any servicing other than cleaning and user maintenance should be done only by authorized Cuisinart Repair Personnel.
12. Do not use the freezer bowl on flames, hot plates or stoves. Do not expose to heat source. Do not wash in dishwasher; doing so may cause risk of fire, electric shock or injury.

SAVE THESE INSTRUCTIONS FOR HOUSEHOLD USE ONLY

NOTICE This appliance has a polarized plug (one blade is wider than the other). To reduce the risk of electric shock, this plug will fit in a polarized outlet only one way. If the plug does not fit fully in the outlet, reverse the plug. If it still does not fit, contact a qualified electrician. Do not attempt to defeat this safety feature.

CAUTION This appliance is for household use. Any servicing other than cleaning and user maintenance should be performed by an authorized service representative.

- Do not immerse base in water.
- To reduce the risk of fire or electric shock, do not disassemble the base.

Note: the base does not contain any user-serviceable parts.

- Repairs should be made only by authorized personnel.
- Check voltage to be sure that the voltage indicated on the name plate agrees with your voltage.
- Never clean with scouring powders or hard implements.

Warning

This content is compiled from multiple sources and is provided for reference purposes only. It may not be complete or fully applicable to all situations. If you are unable to resolve your issue, please contact the product manufacturer or an authorized service provider for official support.