

Installation

Follow these instructions carefully to ensure a proper installation of this refrigerator and to prevent accidents before using it.

WARNING

- Use the refrigerator only for its intended purpose as described in this manual.
- Any servicing must be performed by a qualified technician.
- Dispose of the product packaging material in compliance with the local regulations.
- To prevent electric shock, unplug the power plug before servicing or replacing parts.

Refrigerator at a glance

The actual refrigerator and provided parts of your refrigerator may differ from the illustrations in this manual, depending on the model and the country.

Type A

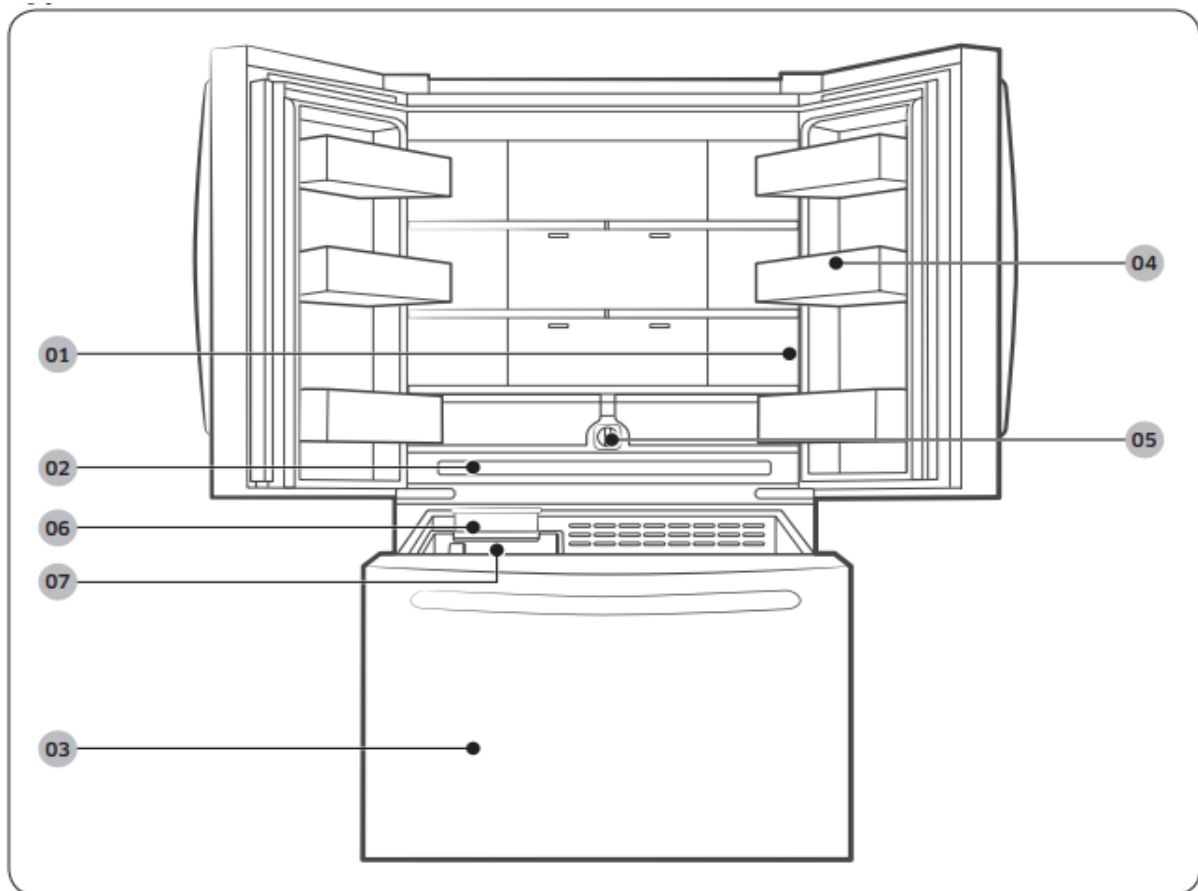

Type B

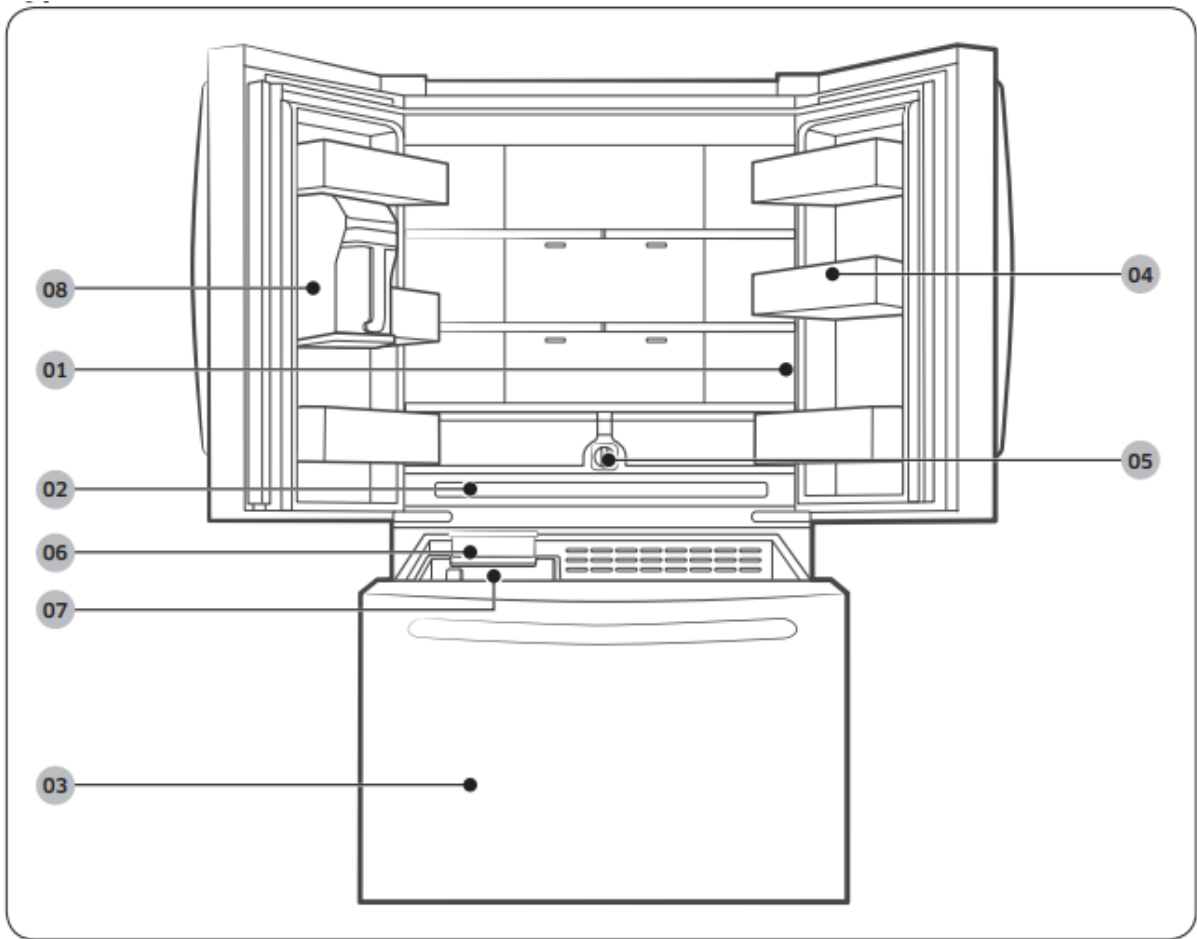

Type C



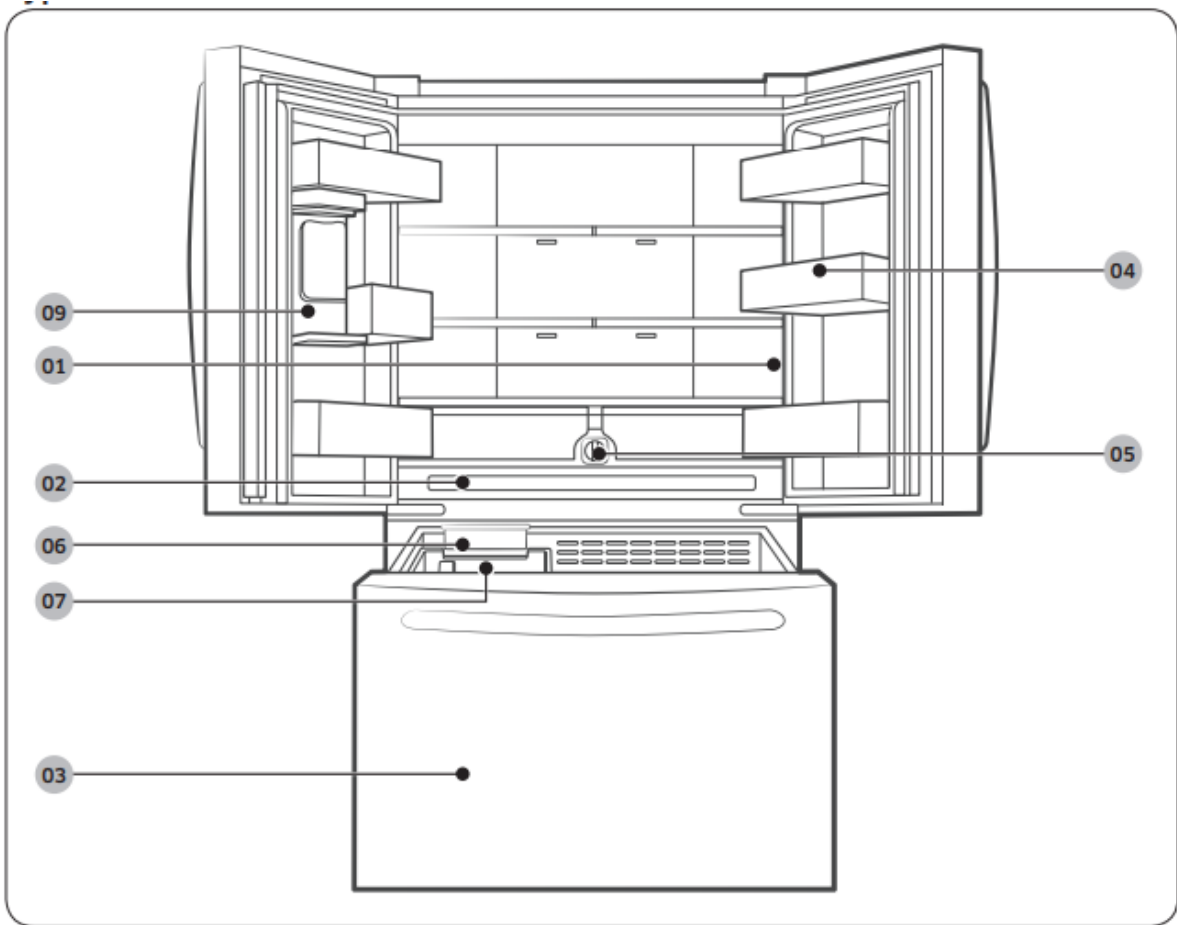

Type D



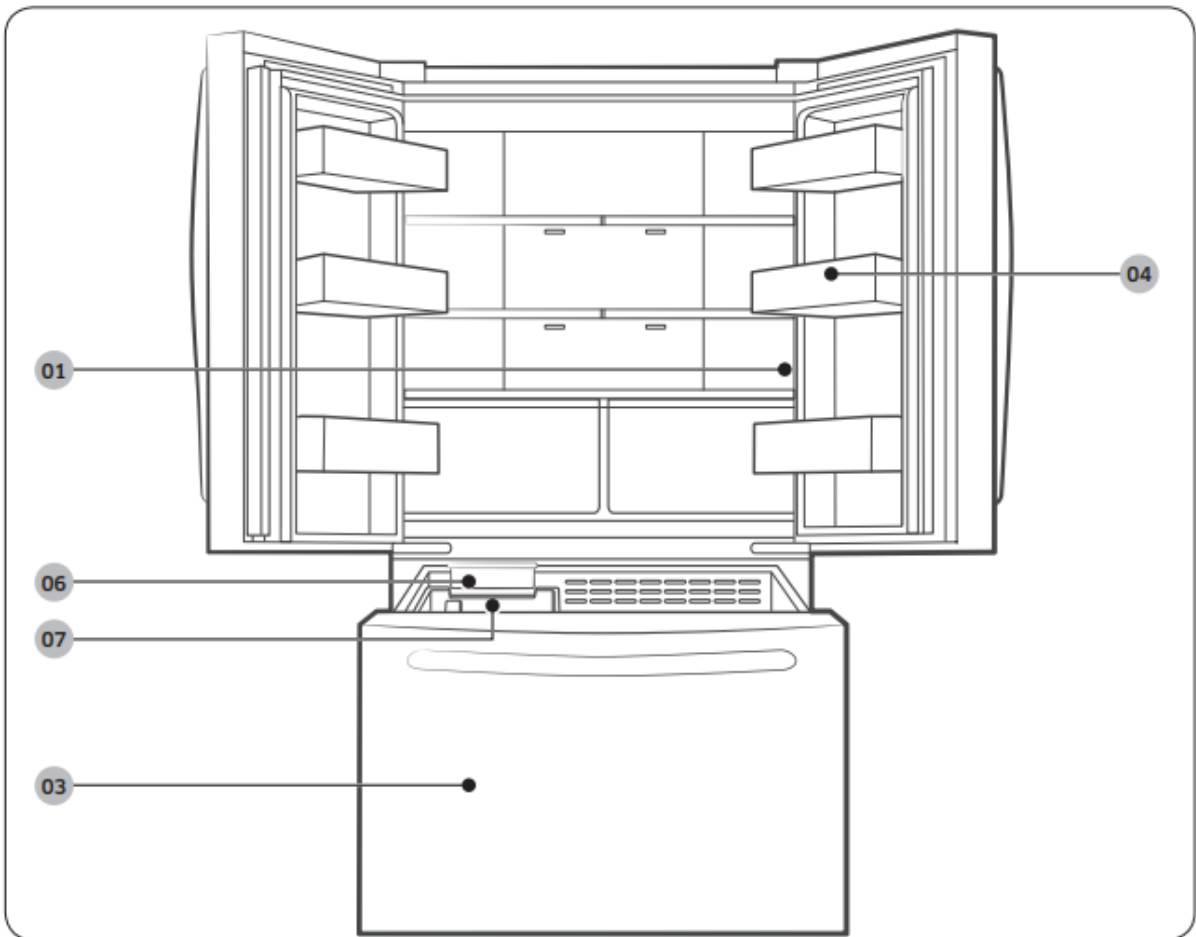

01. Main panel

02. Wide Pantry *

03. Freezer

04. Door bins

05. Water filter *

06. Ice Maker *

07. Ice bucket *

08. AutoFill Pitcher *

09. Inner dispenser *

* applicable models only

NOTE

- For energy efficiency, keep all shelves, drawers, and baskets in their original positions.
- When closing the door, make sure the vertical hinged section is in the correct position to avoid scratching the other door.
- If the vertical hinged section is reversed, put it back into the correct position, and then close the door.

- Moisture may form at times on the vertical hinged section.
- If you close a door forcefully, the other door may open.
- If the internal or external LED lamp is out of order, contact a local Samsung service center.
- If the door is left open for too long, the top internal LED will blink. This is normal.

Operations

Main panel

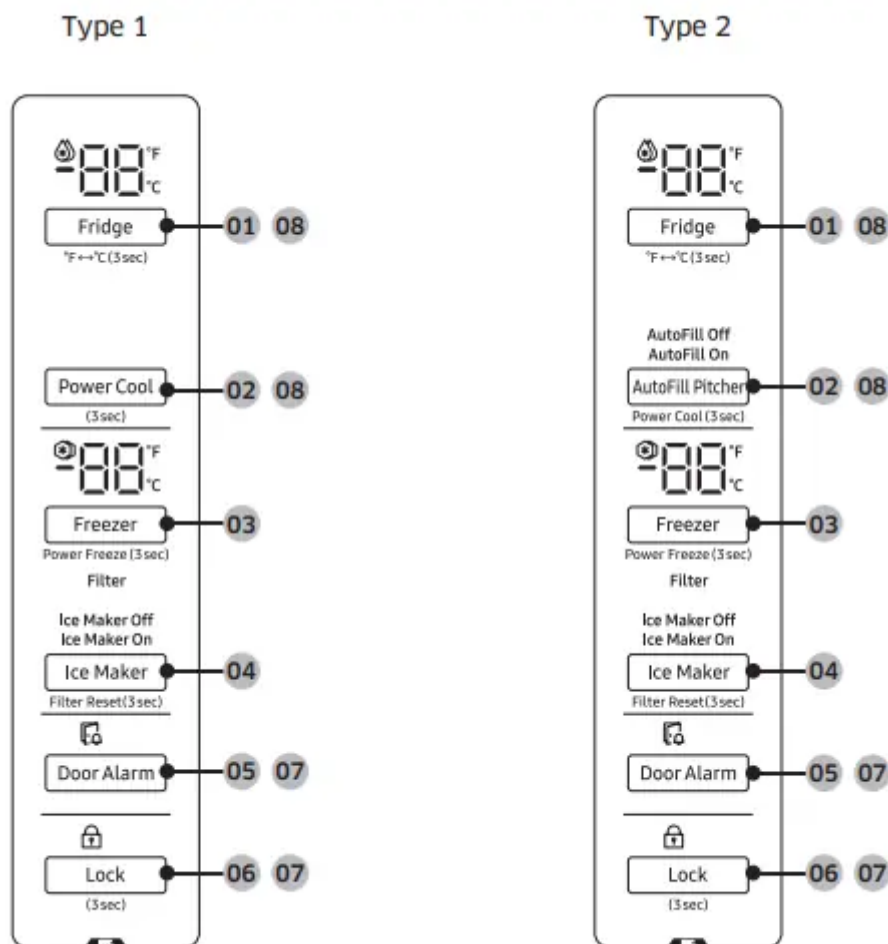

01. Fridge / °F ↔ °C
02. Power Cool / AutoFill Pitcher *
03. Freezer / Power Freeze
04. Ice Maker / Filter Reset *
05. Door Alarm
06. Lock
07. Sabbath Mode

08. Cooling Off

* applicable models only

NOTE

- When you change the temperature on the panel, the panel displays the actual temperature inside the refrigerator until the temperature matches the temperature you set. Then, the panel displays the new set temperature. Note that it will take time for the refrigerator to reach the new temperature. This is normal. During this time, you do not need to set the temperature again.
- To ensure optimal performance, we recommend setting the temperature to 0 °F (-18 °C) for the freezer, and 37 °F (3 °C) for the fridge.
- The temperature in the refrigerator may rise if you open the door frequently or put a large amount of food into the refrigerator. If this happens, the temperature display blinks until the refrigerator returns to the specified temperature settings. If the blinking continues for an extended time, contact a local Samsung service center for technical assistance.
- The display of the main panel turns on only if the door is opened and turns off if the door is closed.
- If you set the Lock function on the main panel, the main panel locks automatically 1 minute after inactivity

01 Fridge / °F ↔ °C (3 sec)

Fridge:

- You can use the Fridge button to set the fridge temperature.
 - Press Fridge repeatedly to select a desired temperature between 34 °F (1 °C) and 44 °F (7 °C).
 - The temperature indicator displays the current temperature or selected temperature.

°F ↔ °C

- You can also use the Fridge button to switch the temperature scale between Celsius and Fahrenheit.
- To switch the temperature scale, press and hold Fridge for 3 seconds to change the current temperature scale.

02 Power Cool (3 sec) / AutoFill Pitcher

Power Cool



- Power Cool speeds up the cooling process at maximum fan speed. This is useful to quickly cool food that spoils quickly, or after the door is left open for some time. The



fridge keeps running at full speed for several hours and then returns to the previous temperature.

- Press and hold Power Cool for 3 seconds.
- Press and hold Power Cool (or AutoFill Pitcher for RF28T502*** model) for 3 seconds.
-

The corresponding indicator () lights up, and the refrigerator will speed up the cooling process for you

AutoFill Pitcher (RF28T502*** model only)

- 
If the Lock indicator () is off, press AutoFill Pitcher turn AutoFill Pitcher on. Then, open the left door of the fridge and insert the water tank. Close the door and the water tank starts to fill with water up to the preset level.

- 
If the Lock Indicator () is on, indicating the Lock function is active, press and hold Lock for 3 seconds to deactivate the Lock function. When the Lock indicator turns off, immediately press AutoFill Pitcher to turn AutoFill Pitcher on. Then, open the left door of the fridge and insert the water tank. Close the door and the water tank starts to fill with water up to the preset level.

NOTE

- When you turn off the Lock function, you must press AutoFill Pitcher within one minute or the Lock function will automatically reactivate. You cannot turn the AutoFill Pitcher function on if the Lock function is active. For more information on the Lock function. To turn the function off, press the AutoFill Pitcher again.
- By default, AutoFill Pitcher is disabled. Enable this function after you have installed the water line.
- AutoFill Off blinks if you open the door and remove or insert the pitcher with the AutoFill Pitcher function off. To stop the blinking, close the door or, turn the AutoFill Pitcher function on.
- The AutoFill Pitcher indicators (AutoFill On / AutoFill Off) blink if there is a leak. If this is the case, follow these steps.
 - Open the rubber cap and drain water.
 - When draining is complete, the indicators stop blinking and turn solid.
 - Close the rubber cap.
- If the indicators continue to blink, this might be a system failure. Contact a local service center.

03 Freezer / Power Freeze (3 sec)

Freezer

- The Freezer button can be used to set the freezer temperature, or to activate Power Freeze. Available temperatures are between 5 °F (-15 °C) and -8 °F (-23 °C).

Power Freeze

Power Freeze speeds up the freezing process at maximum fan speed. The freezer keeps running at full speed for 50 hours and then returns to the previous temperature.

- To activate Power Freeze, press and hold Freezer for 3 seconds. The corresponding indicator () lights up, and the refrigerator will speed up the freezing process for you.
- To deactivate, press and hold Freezer for 3 seconds again. The freezer returns to the previous temperature setting.
- To freeze large amounts of food, activate Power Freeze for at least 20 hours before putting food in the freezer.

NOTE Using Power Freeze increases power consumption. Make sure you turn it off and return to the previous temperature if you do not intend to use it.

04 Ice Maker / Filter Reset (3 sec)

Ice Maker

Press Ice Maker to turn the ice maker on or off.

- The ice maker has 2 indicators (Ice Maker On / Ice Maker Off) to indicate its operating status.
- When the ice maker operates, the corresponding indicator (Ice Maker On) turns on.
- When the ice maker is turned off, the corresponding indicator (Ice Maker Off) turns on.
To enable ice making, you must turn the ice maker on.

Filter Reset

After about 6 months (and typically, about 300 gallons (1200 L) of water), the Filter indicator blinks red for several seconds when you open the door, reminding you that the filter needs to be replaced. When this happens, replace the filter, and then press and hold Ice Maker for 3 seconds. The filter lifecycle will be reset and the Filter indicator turns off.

NOTE

- Some regions have relatively large amounts of lime in their water. This can reduce the lifecycle of the filter. In these areas, you will have to replace the water filter more often than specified above.

- If water is not dispensing properly, the water filter is most likely clogged. Replace the water filter.

05 Door Alarm

Door Alarm

- If the door is left open for more than 2 minutes, an alarm will sound and the alarm indicator will blink. You can toggle the alarm on and off by pressing Door Alarm. The alarm is enabled by factory default. If the door is left open for 5 minutes, internal lights (in the fridge and freezer) will blink for 10 seconds and then turn on. The whole process will be repeated every minute for 5 minutes. This is to alert hearing-impaired users that a door is open. Note that this function is normal.

06 Lock (3 sec)

Lock

- To prevent accidental setting changes, press and hold Lock for 3 seconds. The main



panel will be disabled and the Lock indicator () will turn on.

- When the Lock function is on, the indicator blinks if any button on the main panel is pressed.
- If you press and hold the button again for more than 3 seconds, the Lock function will be deactivated.
- However, the Lock function will be reactivated if no button is pressed within 1 minute.

07 Sabbath Mode

The Sabbath mode stays active for 85 hours once it is activated. After that, it will be deactivated automatically.

- To activate Sabbath Mode, press and hold Door Alarm and Lock simultaneously for 5 seconds. When the refrigerator is in Sabbath mode, the buttons, the display, and the internal lights do not function. The refrigerator and freezer, however, continue to cool.
- To deactivate Sabbath Mode, press and hold Door Alarm and Lock simultaneously again for 5 seconds.

NOTE

- If the refrigerator powers off and restarts (for example, if there is a power failure), the Sabbath mode remains active. To end Sabbath Mode, you must deactivate it as described above.
- Controls must be unlocked before activating Sabbath mode.

08 Cooling Off

- Cooling Off mode (also called Shop mode) is designed for use by retailers when they are displaying refrigerators on a retail floor.
- In Cooling Off mode, the refrigerator's fan motor and lights operate normally, but the compressors do not run so neither the refrigerator nor the freezer become cold.
- To enter or exit the Cooling Off mode, press and hold Fridge and Power Cool (or Fridge and AutoFill Pitcher for RF28T502*** model) simultaneously for 6 seconds. Then, when the display blinks, press Lock.
- When the Cooling Off mode is on, the refrigerator chime sounds, and the refrigerator shows "0" on the fridge temperature display and "FF" on the freezer temperature display

Special features

Water pitcher (AutoFill Pitcher) (applicable models only): The AutoFill Pitcher function lets you enjoy cold brewed tea in your refrigerator

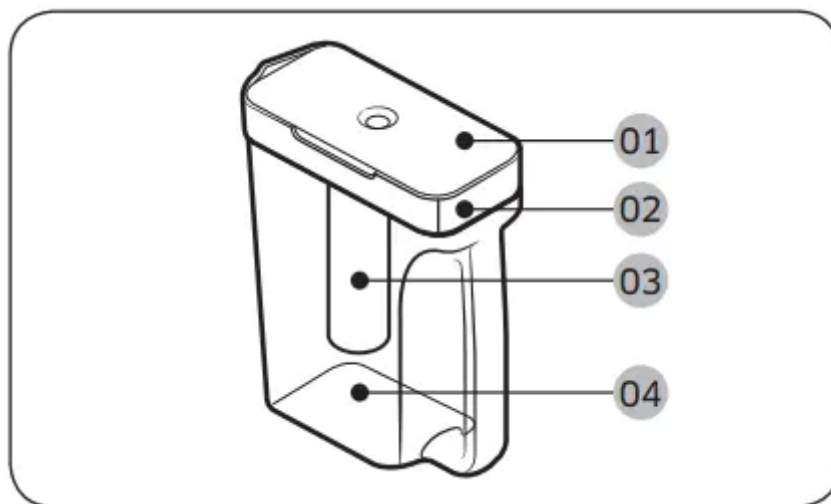

01. Lid
02. Sealed mouth
03. Infuser
04. Body

To fill the Water pitcher

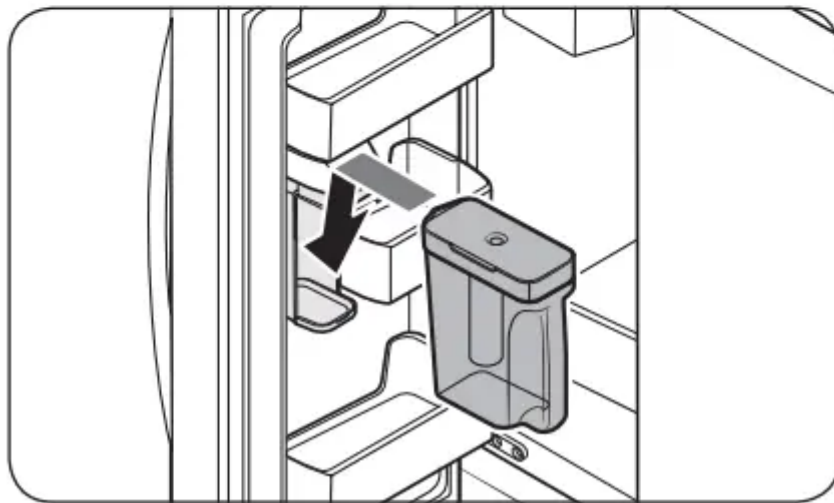
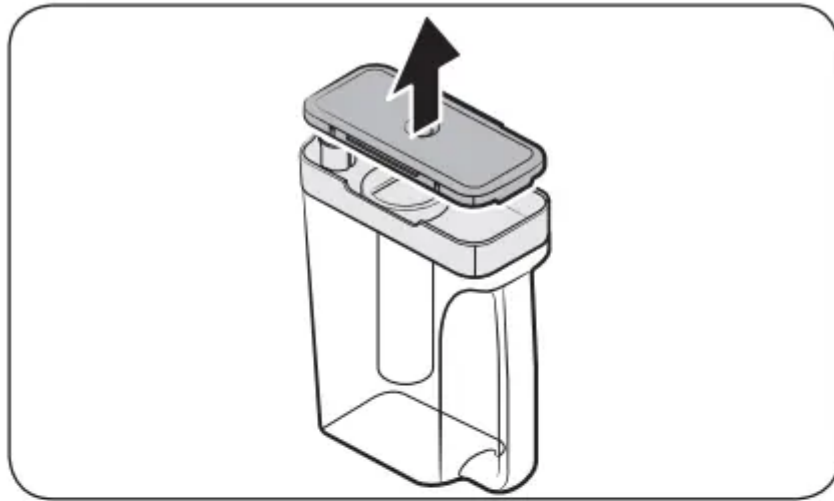

1. Grasp a handle groove of the sealed mouth, and then pull up to open the lid.
2. Put tea leaves or fruit to your taste into the infuser. **NOTE** If you want to keep the infused water in its initial concentration, turn the AutoFill Pitcher function off.
3. Enable the AutoFill Pitcher function on the main panel. Open the left door of the fridge door, and then mount the water pitcher onto the holder. Push it straight in as shown in the illustration on the left.
4. Close the door. The water pitcher will start to fill with chilled water a short time later.
CAUTION: Make sure the water pitcher fits in the water pitcher holder.
5. To drink tea, open the door and detach the water pitcher. Pull it straight out.

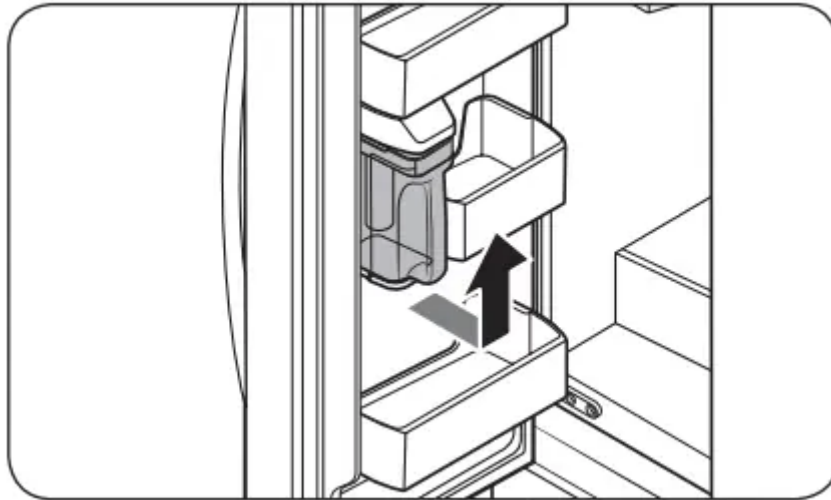

CAUTION

- We recommend consuming fruit infused water within 24 hours. After that, the infused water can spoil over time.
- You must clean the water pitcher after you have consumed the infused water. Also clean the water pitcher if you haven't used it for a long time.

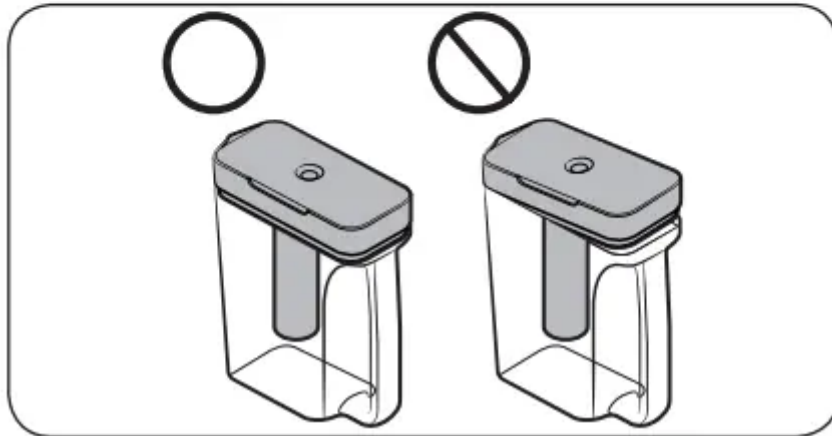
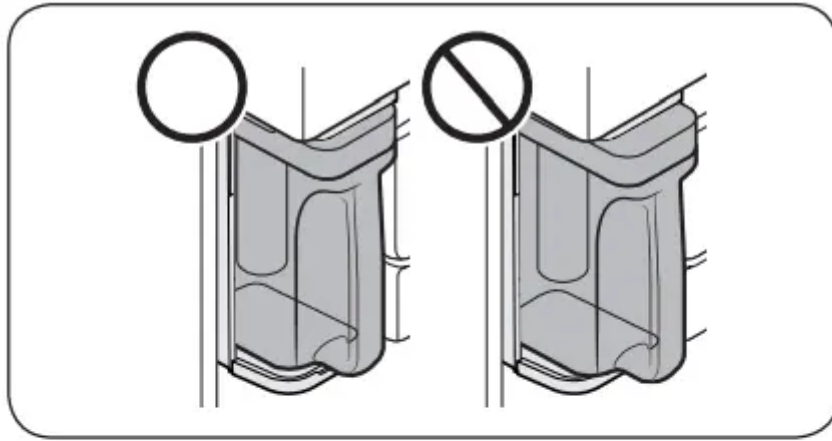

- To prevent the water pitcher from tipping over or leaking, make sure the water pitcher fits in the water pitcher holder.
- To prevent the water pitcher from spilling over or leaking, make sure the sealed mouth is properly inserted.



NOTE

- If the front side (specifically marked area) of the water pitcher has too much moisture, the water pitcher may not fully fill. Remove the moisture, and then try again.

- The AutoFill Pitcher function will stop supplying water to the water pitcher if the water pitcher does not fill after a certain amount of time. If this happens, check if the water line is properly connected. Remove and reinsert the water pitcher, and then try again.

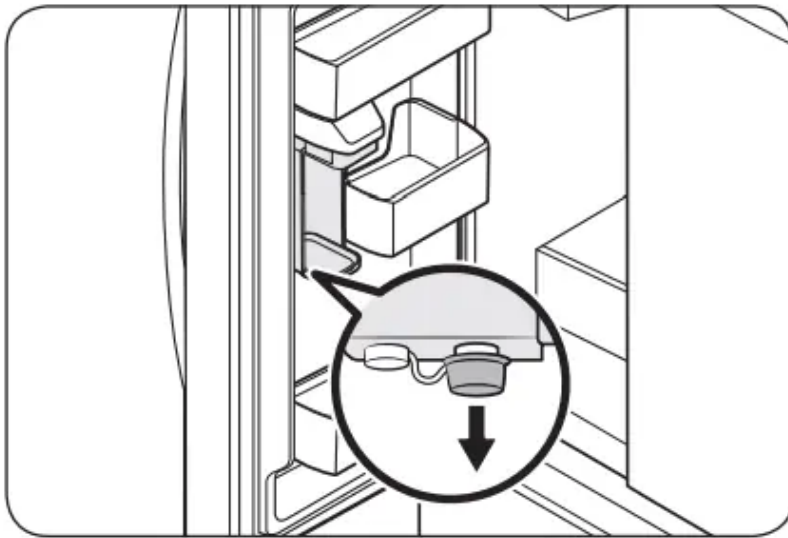

NOTE

- Wipe around the infuser holder if the infuser overflows or leaks.
- Water drops off if the rubber cap is opened.
- The AutoFill Pitcher indicator (AutoFill On / AutoFill Off) blinks if there is a leak. In case of a leak, open the rubber cap so that the leaked water drains. The indicator will then turn off. However, if the indicator continues to blink, there might be a system failure. Contact your local Samsung service center.
- The AutoFill Pitcher indicators (AutoFill On/ AutoFill Off) blink if there is a leak. See page 39 for more information.
- AutoFillOn blinks if you open the door and remove or insert the pitcher with the AutoFill Pitcher function off. To stop the blinking, close the door or, turn the AutoFill Pitcher function on.

Inner dispenser (applicable models only)

To dispense chilled water, put a water glass under the dispenser, and then push the dispenser lever.

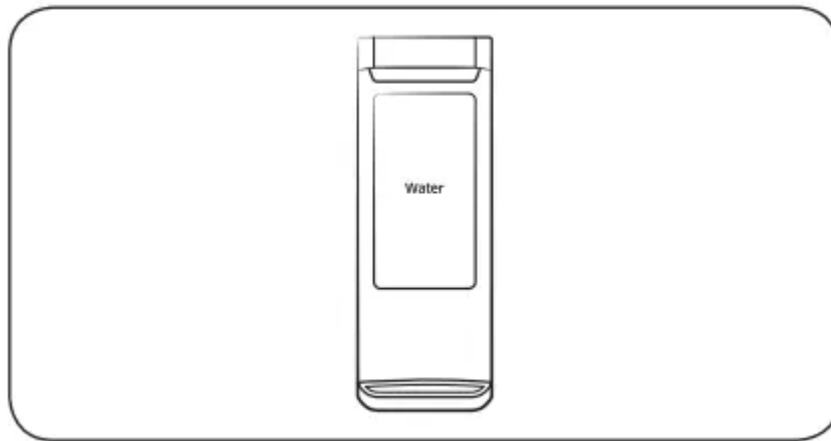

NOTE

- The dispenser will stop dispensing if you keep pushing the dispenser lever for about 1 minute. To dispense more water, release and push the lever again.
- Make sure the glass is in line with the dispenser to prevent the dispensed water from spilling out.
- If you do not use the water dispenser for 2-3 days, the dispensed water may have an abnormal smell or taste. This is not a system failure. Discard the first 1-2 glasses of water.
- Do not put cups or other containers on the water tray under the inner dispenser as they may fall on the floor.

Ice maker

The refrigerator has a built-in ice maker that automatically dispenses ice so that you can enjoy filtered water with cubed or crushed ice.

Ice making: After you have installed your refrigerator and plugged it in, follow these instructions to ensure proper ice making and to keep the ice bucket full of ice:

1. Let the refrigerator operate for at least 24 hours to ensure optimal performance.
2. Dispense the first 4 to 6 ice cubes into a glass.
3. Wait another 8 hours and dispense another 4 to 6 ice cubes.
4. Then, wait another 16 hours and dispense the first glass-full of ice.

NOTE

- If you consume all the ice at once, you must wait 8 hours before dispensing the first 4 to 6 cubes. This ensures that the ice bucket is filled with ice properly.
- Ice cubes generated rapidly may look white, which is normal.

Diagnosis

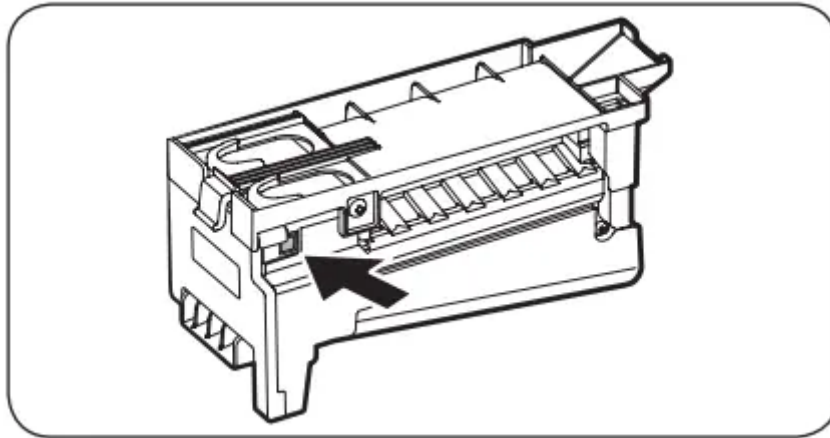

If ice does not dispense, first check the ice maker.

1. Press Test on the side of the ice maker. You will hear a chime (ding-dong) when you press the button.
2. You will hear another chime if the ice maker is operating properly.

CAUTION

- If the ice making chime rings repeatedly, contact your waterline installer or a local Samsung service center.
- Do not press Test repeatedly after the ice tray is filled with ice or water. Water may overflow or ice may jam.
- Do not put food in the ice bucket. The frozen food may damage the ice maker, especially when you open or close the door.
- When the refrigerator recovers power after a power failure, the ice bucket may contain a mix of melted and jammed ice cubes, which can prevent the ice maker from working properly. To prevent this, make sure to empty the ice bucket so the ice bucket can refill with fresh, loose ice cubes.
- Do not put fingers or any objects into the dispenser outlet or the ice maker. This can cause physical injury or property damage.
- When reinserting the ice maker tray, make sure that the tray is properly centered at the entrance. Otherwise, the tray can get stuck.

If You Turn the Ice Maker Off: If you press and hold Ice Maker for more than 3 seconds to turn the ice maker off, make sure to remove all ice cubes from the ice bucket. Remaining ice cubes may clump together, making it difficult to remove them.

NOTE: Removal of the ice bucket does not affect the thermal and mechanical performance of the refrigerator.

Water clouding: Water supplied to the refrigerator flows through a core alkaline filter. During this filtering process, the water pressure of the water increases and the water becomes saturated with oxygen and nitrogen. This causes the water to look misty or cloudy temporarily when dispensed. This is normal and the water will look clear after a few seconds.

Maintenance

Handling and care

Fridge shelves: The appearance of the shelves differs by model.

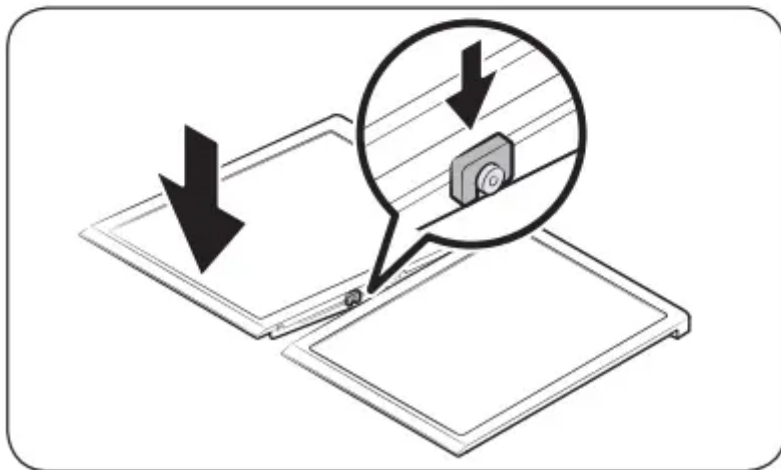
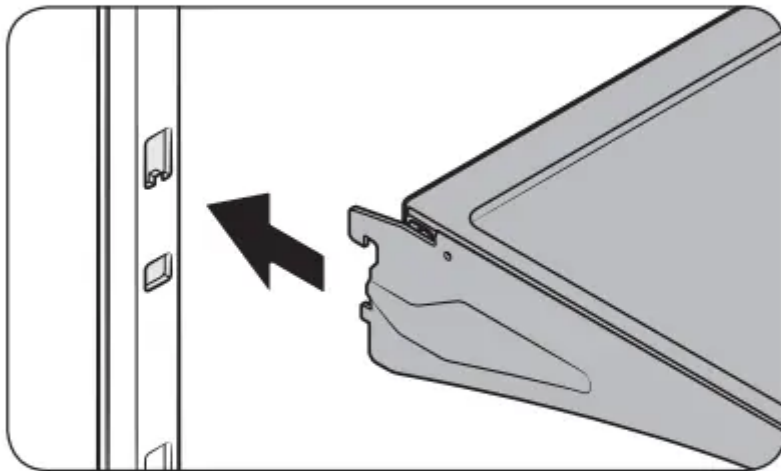
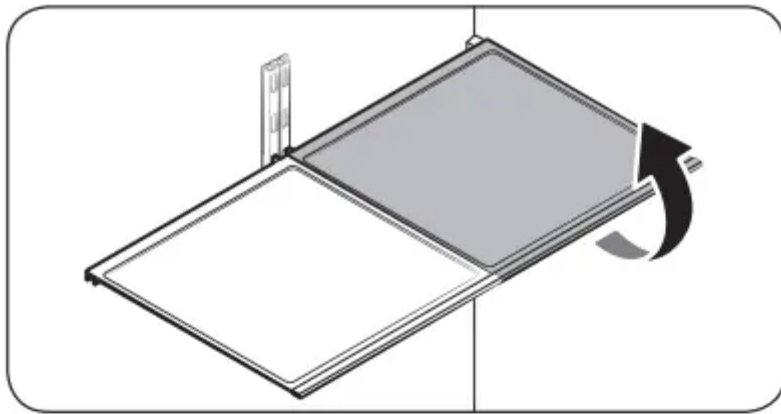

- To remove a shelf, fully open the corresponding door. Hold the front of the shelf, and then gently lift up and slide out.

NOTE: Do not lift up the shelf fully when removing or reinserting the shelf. The rear wall of the fridge room can be dented.

- To reinsert, hold the shelf at an angle so the front is higher than the back, and then insert the top hook into the top shelf notch. Then, lower the shelf and insert the bottom shelf hook into the bottom shelf notch.

CAUTION

- The tempered glass shelves are heavy. Use caution when removing them.
- The shelf must be inserted correctly. Do not insert upside down.
- Glass containers may scratch the surface of glass shelves.

Door bins

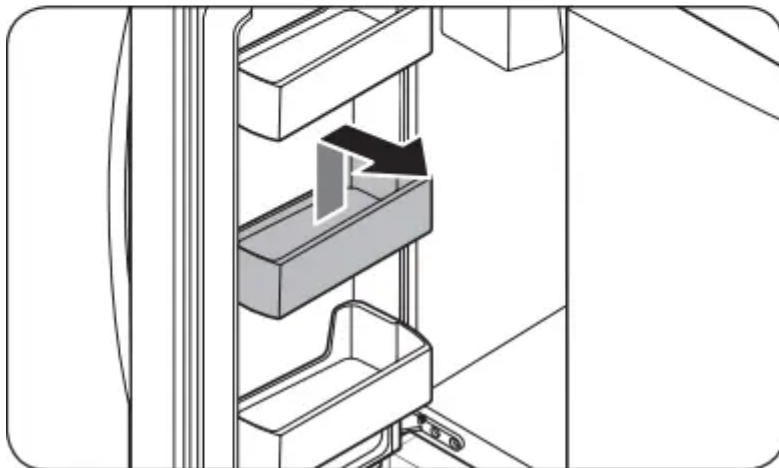
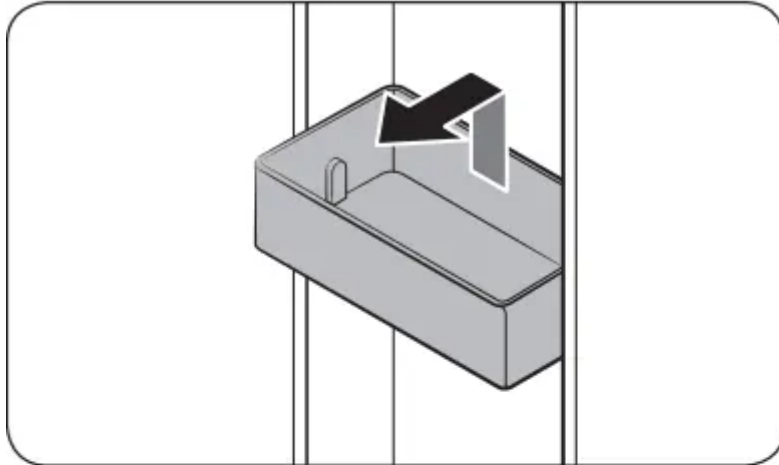

- To remove the door bin, hold the front sides of the bin, and then gently lift up to remove.
- To reinsert, insert the door bin slightly above its final location making sure that the back of the bin is against the door. Hold the rear of the door bin with both hands, and then press down so that it fits snugly.

CAUTION

- Do not remove a bin that is filled with food. Empty the bin beforehand.
- Use caution when opening the door if the bottom bin contains larger bottles, which may fall over.
- Do not allow children to play with the bins. Sharp corners of the bin may cause injury.

Fridge drawers - Vegetable / fruit drawers

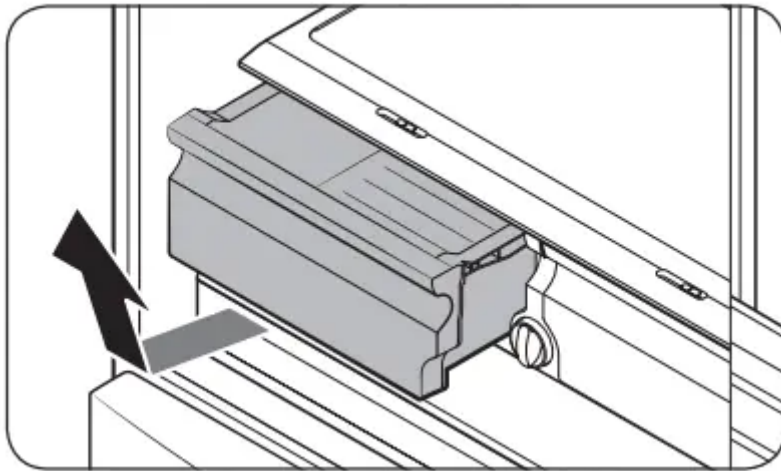

Gently lift up the front of the drawer and slide out.

- We recommend that you remove the door bins before removing the drawer. This is to prevent damage to the door bins.
- To reinsert, insert the drawer into the frame rails and then slide inward.

Wide Pantry (applicable models only)

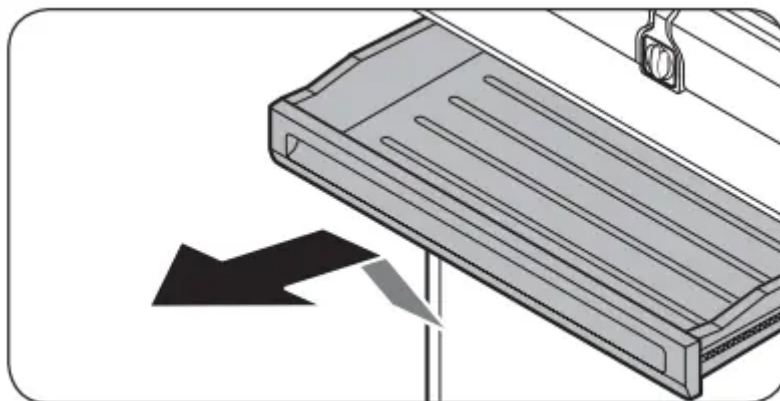

- To remove, fully open the Wide Pantry. Then, slightly lift the front side and pull straight out.
- To reinsert, push the rails to the back of the refrigerator. Then, place the Wide Pantry onto the rails and slide it back until it is in place.

Freezer baskets

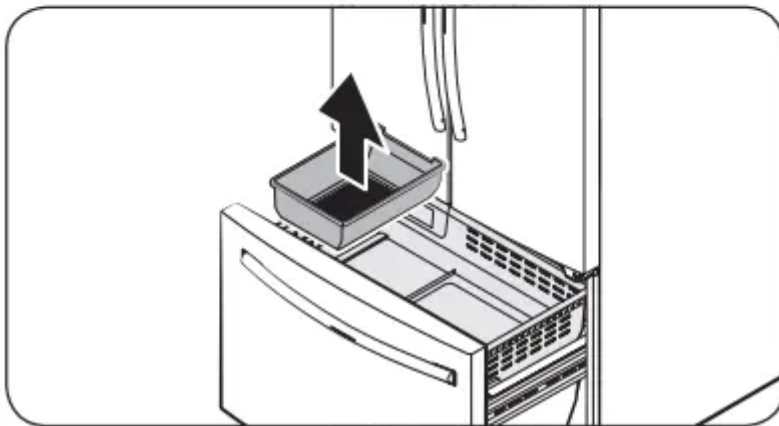
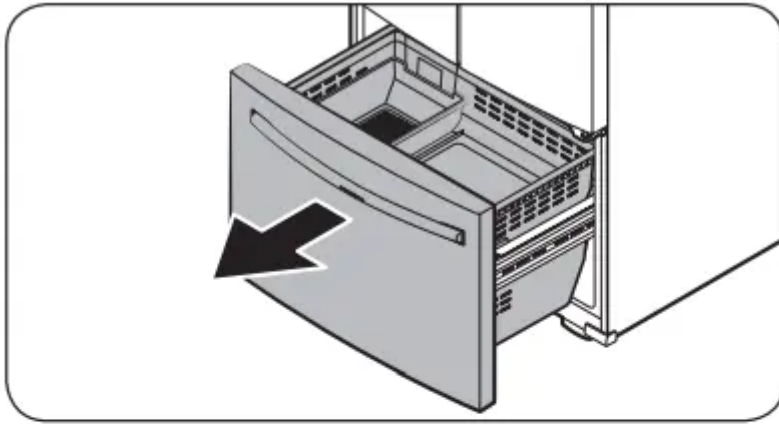

1. Fully open the freezer drawer
2. Lift the ice bucket to remove

Upper basket

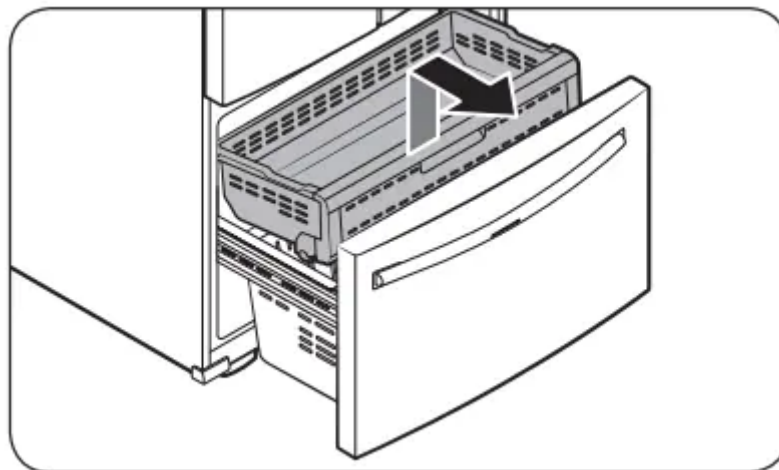

- To remove, fully slide open the freezer drawer. Lift up the front of the upper basket and pull to remove.
- To reinsert, align the front wheels of the upper basket with the end of the lower basket. Slide the upper basket to the front.

Lower basket

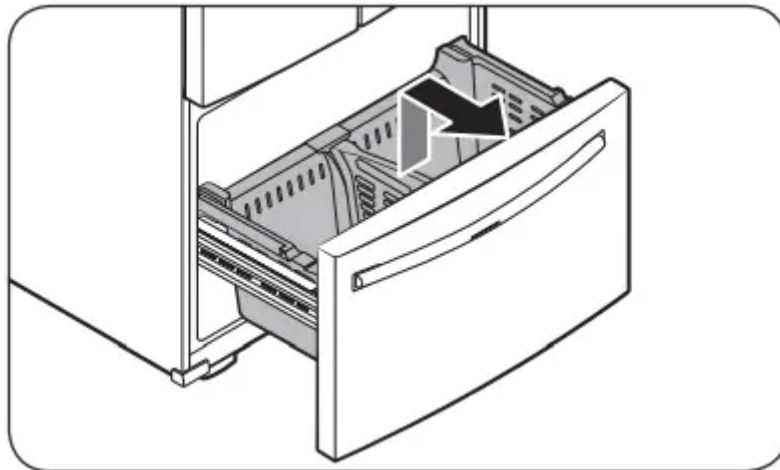

- To remove, first remove the upper basket. Then, tilt up the front of the lower basket to pull out.
- To reinsert, put the basket onto the rail assembly rear side first.

CAUTION

- Do not twist the basket when removing or reinserting the basket. The basket can be scratched.
- To prevent physical injury, property damage, or suffocation, keep children away from freezer baskets that have been removed.
- Do not remove the divider.
- Put the wheels of the upper basket on the end of the rails of the lower basket. Then, slide the upper basket all the way to the front. Otherwise, the drawer will not open or close properly, which will cause frost to build up.

Cleaning

Interior and exterior

WARNING

- Do not use benzene, thinner, home/car detergent, or Clorox™ to clean the refrigerator. They may damage the surface of the refrigerator and cause a fire.
- Do not spray water onto the refrigerator. This may cause electric shock.

Regularly use a dry cloth to remove all foreign substances such as dust or water from the power plug terminals and contact points.

1. Unplug the power cord.
2. Use a moistened, soft, lint-free cloth or paper towel to clean the refrigerator's interior and exterior.

3. When done, use a dry cloth or paper towel to dry well.
4. Plug in the power cord.

Rubber seals

- If the rubber seals of a door become dirty, the door may not close properly and reducing refrigerator performance and efficiency. Use a mild detergent and damp cloth to clean the rubber seals. Then, dry well with a cloth.

Rear panel

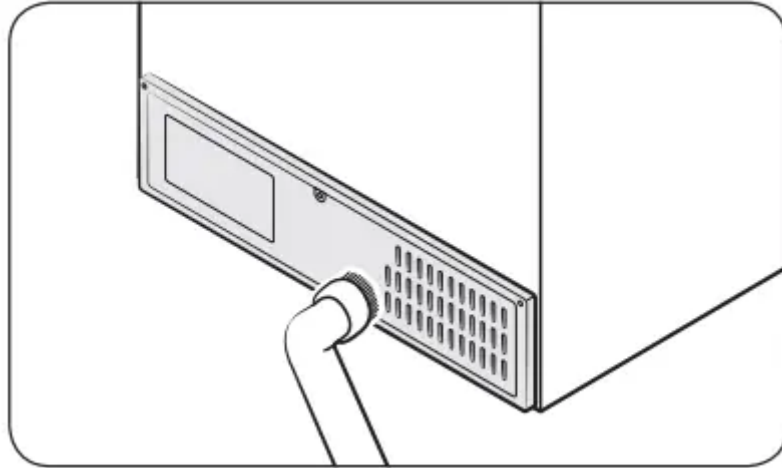

- To keep cords and exposed parts of the rear panel free of dirt, vacuum the panel once or twice a year.
- CAUTION: Do not remove the rear panel cover. Electric shock may occur

Replacement

Water filter

WARNING

- Do not use third-party water filters. Use only Samsung-provided or -approved filters.
- Unapproved filters may leak and damage the refrigerator, causing electric shock. Samsung is not responsible for any damage that may occur from use of third-party water filters.

The Filter Reset indicator () turns red to let you know it is time to replace the water filter. Before replacing the filter, make sure the water supply line is shut off.

1. . Shut off the water supply line.
2. Turn the knob of the filter cartridge 90 degrees counterclockwise (1/4 turn). The filter cartridge unlocks.

3. Pull out to remove the cartridge.

- If the water filter is severely contaminated, the cartridge may not be easy to remove. If that is the case, use force to remove the cartridge.
- To prevent water leaks from the filter opening, pull the cartridge straight out while removing it.

4. Insert a new filter cartridge. Use only Samsung-provided or approved filters.

5. Turn the cartridge knob clockwise to lock into place.

6. Press and hold Ice Maker on the main panel for 3 seconds to reset the life cycle detector. The Filter Reset indicator () turns off.

NOTE: For type A model (RF28T5000***) discard first 2 buckets of ice after changing the filter

Reverse osmosis water filtration system

The water pressure of the water supply system to a reverse osmosis water filtration system must be between 30 to 120 psi (206 to 827 kPa). The water pressure of the reverse osmosis water filtration system to the refrigerator's cold water line must be at least 40 psi (276 kPa). If the water pressure is below these specifications:

- Check if the sediment filter in the reverse osmosis system is blocked. Replace the filter if necessary.
- Refill the water tank in the reverse osmosis system with water.
- If your refrigerator has a water filter, it may further reduce the water pressure when used in conjunction with a reverse osmosis system. Remove the water filter. For more information or servicing, contact a licensed plumbing professional.

Ordering a new filter

- To purchase a new water filter, contact a local Samsung service center on the web.

LED Lamps

- To replace the lamps of the refrigerator, contact a local Samsung service center.
- **WARNING:** The lamps are not user-serviceable. Do not attempt to replace a lamp yourself. This can cause electric shock.

Troubleshooting

Before calling for service, review the symptoms and recommended solutions below. If none of the suggested solutions resolve your problem, please visit our website. Note that you will be charged for any service visits in which no defects were found.

General

Temperature

Fridge/freezer does not operate. Fridge/freezer temperature is warm.	Power cord is not plugged in properly.	Properly plug in the power cord.
	Temperature control is not set correctly.	Set the temperature lower.
	Refrigerator is located near a heat source or direct sunlight.	Keep the refrigerator away from direct sunlight or a heat source.
	Not enough clearance between refrigerator and nearby walls or cabinets.	Make sure there is a gap of at least 2.5 inches (5 cm) between the refrigerator back and sides and any nearby walls or cabinets.
	Energy Saver mode is activated.	Deactivate Energy Saver mode.
	The refrigerator is overloaded. Food is blocking the refrigerator vents.	Do not overload the refrigerator. Do not allow food to block vents.
Fridge/freezer is over-cooling.	Temperature control is not set correctly.	Set the temperature higher.
Interior wall is hot.	Refrigerator has heat-proof piping in the interior wall.	To prevent condensation from forming, the refrigerator has heat-proof piping in the front corners. If the ambient temperature rises, this equipment may not work

Symptom	Possible causes	Solution

		effectively. This is not a system failure.
--	--	--

		ambient temperature rises, this equipment may not work effectively. This is not a system failure.
--	--	---

Odors

Symptom	Possible causes	Solution
Refrigerator has odors.	Spoiled food.	Clean the refrigerator and remove any spoiled food.
	Food with strong odors.	Make sure strong smelling food is wrapped airtight.

Frost

Symptom	Possible causes	Solution
Frost around the vents.	Food is blocking the vents.	Make sure no food blocks the refrigerator vents.
Frost on interior walls.	Door is not closed properly.	Make sure food does not block the door. Clean the door gasket.
Fruits or vegetables are frozen.	Fruits or vegetables are stored in the Cool Select Zone.	Do not store most kinds of fruit or vegetables in the Cool Select Zone.

Condensation

Symptom	Possible causes	Solution
---------	-----------------	----------



Condensation forms on the interior walls.	If door is left open, moisture enters the refrigerator.	Remove the moisture and do not leave a door open for extended periods of time.
	Food with high moisture content.	Make sure food is wrapped airtight.

Water/ice (dispenser models only)

Symptom	Possible causes	Solution
Water flow is weaker than normal.	<ul style="list-style-type: none"> Water pressure is too low. 	<ul style="list-style-type: none"> Make sure the water pressure is between 30 to 120 psi (206 to 827 kPa).
Ice maker makes a buzzing sound.	<ul style="list-style-type: none"> The ice maker function is activated, but the water supply to the refrigerator has not been connected. 	<ul style="list-style-type: none"> Press Ice Maker.
Ice maker does not make ice.	<ul style="list-style-type: none"> Ice maker has just been installed. 	<ul style="list-style-type: none"> You must wait for 12 hours for the refrigerator to make ice.
	<ul style="list-style-type: none"> Freezer temperature is too high. 	<ul style="list-style-type: none"> Set the freezer temperature below 0 °F (-18 °C) or -4 °F (-20 °C) in warm ambient air.
	<ul style="list-style-type: none"> Dispenser panel Lock is activated. 	<ul style="list-style-type: none"> Deactivate dispenser panel Lock.
	<ul style="list-style-type: none"> Ice maker is off. 	<ul style="list-style-type: none"> Turn on the ice maker.
Ice does not dispense.	<ul style="list-style-type: none"> Ice may jam if the ice dispenser is not used for a long 	<ul style="list-style-type: none"> If you won't be using the refrigerator for a long

	time (approx. 3 weeks).	time, empty the ice bucket and turn off the ice maker.
	<ul style="list-style-type: none"> Ice bucket is not properly inserted. 	<ul style="list-style-type: none"> Make sure the ice bucket is properly inserted.
	<ul style="list-style-type: none"> Water line is not connected properly or water supply is not on. 	<ul style="list-style-type: none"> Check if the water line is installed correctly. Check if the water line stop cock is closed.
Water does not dispense.	<ul style="list-style-type: none"> Water line is not connected properly or water supply is not on. 	<ul style="list-style-type: none"> Check if the water line is installed correctly. Check if the water line stop cock is closed.
	<ul style="list-style-type: none"> Dispenser panel Lock is activated. 	<ul style="list-style-type: none"> Deactivate dispenser panel Lock.
	<ul style="list-style-type: none"> A third-party water filter was installed. 	<ul style="list-style-type: none"> Use only Samsung-provided or approved filters. Unapproved filters may leak and damage the refrigerator.
	<ul style="list-style-type: none"> Water filter indicator turns on or blinks. 	<ul style="list-style-type: none"> Replace the water filter. After replacing, reset the filter indicator sensor.

Do you hear abnormal sounds from the refrigerator?

These sounds are normal.

- When starting or ending an operation, the refrigerator may make sounds similar to a car engine ignition. As the operation stabilizes, the sounds will decrease.

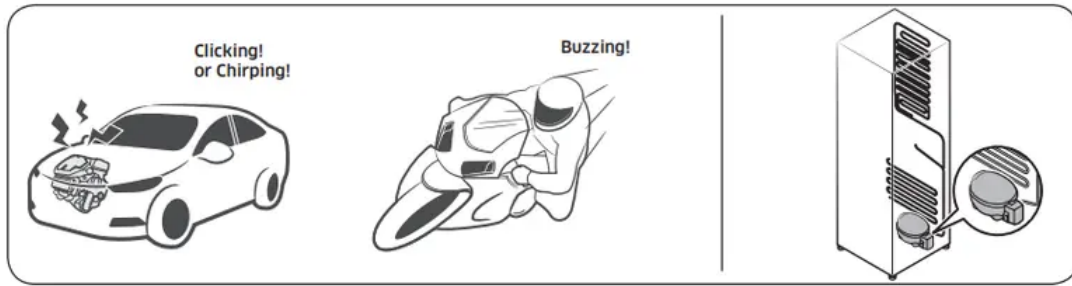

- While the fan is operating, these sounds may occur. When the refrigerator reaches the set temperature, the fan sound will stop.



- During a defrost cycle, water may drip on the defrost heater, causing sizzling sounds.



- As the refrigerator cools or freezes, refrigerant gas moves through sealed pipes, causing bubbling sounds.

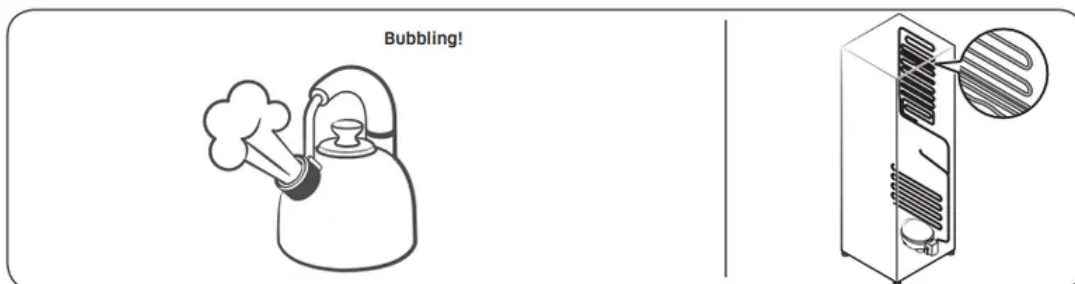

- As the refrigerator temperature increases or decreases, plastic parts contract and expand, creating knocking noises. These noises occur during the defrosting cycle or when electronic parts are working.

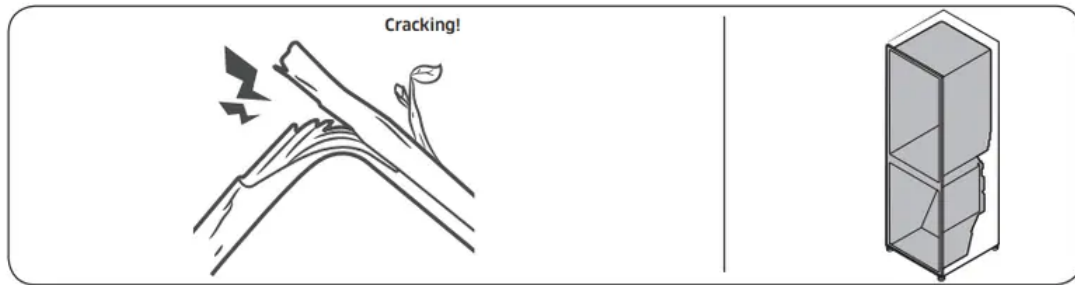

- For ice maker models: When the water valve opens to fill the ice maker, you may hear a buzzing sound.
- Due to pressure equalizing when you open and close the refrigerator door, you may hear a whooshing sound.

Warning

This content is compiled from multiple sources and is provided for reference purposes only. It may not be complete or fully applicable to all situations. If you are unable to resolve your issue, please contact the product manufacturer or an authorized service provider for official support.