

PRODUCT OVERVIEW

Parts

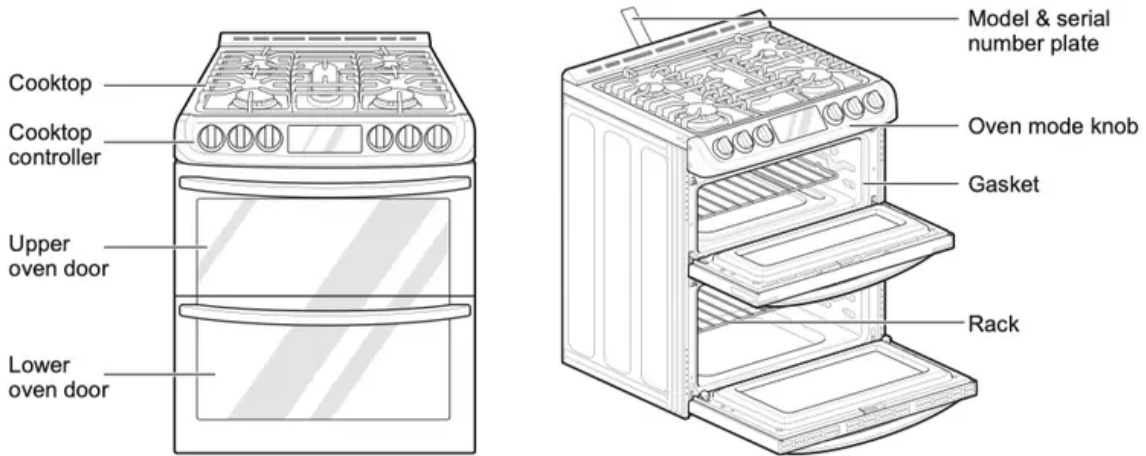

Accessories

Included Accessories

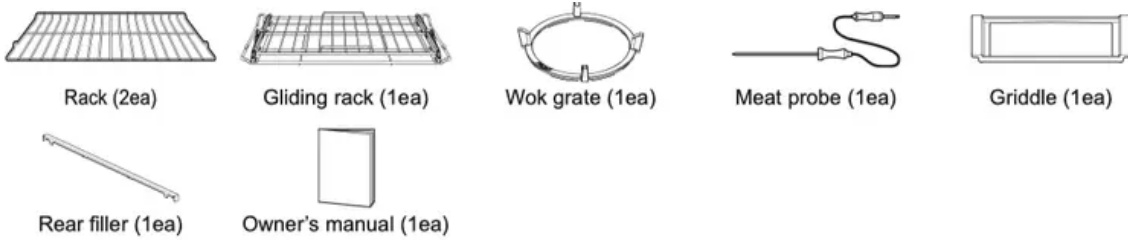

Anti-tip kit

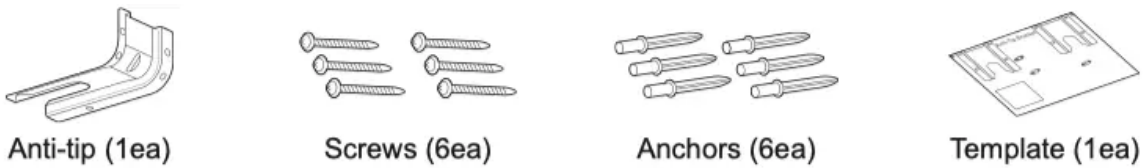

LP nozzle conversion kit

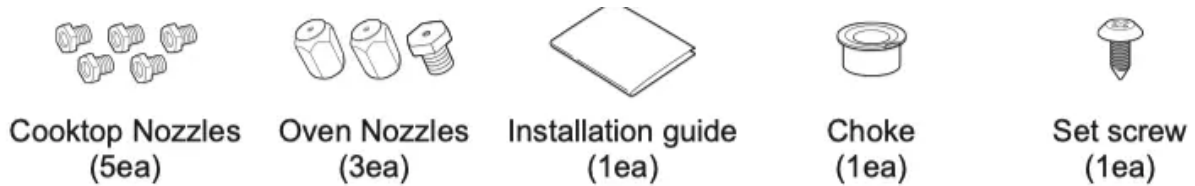

EasyClean™ kit





Spray bottle (1ea)



Non-scratch scouring pad (1ea)

Optional Accessories

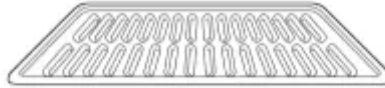

Grid



Broiler pan

NOTE

- Contact LG Customer Service at 1-800-243-0000 (1-888-542-2623 in Canada) if any accessories are missing.
- For your safety and for extended product life, only use authorized components.
- The manufacturer is not responsible for product malfunction or accidents caused by the use of separately purchased, unauthorized components or parts.
- The images in this guide may be different from the actual components and accessories, which are subject to change by the manufacturer without prior notice for product improvement purposes.

OPERATION

Gas Surface Burners

Before Use

Read all instructions before using.

Make sure that all burners are properly placed.

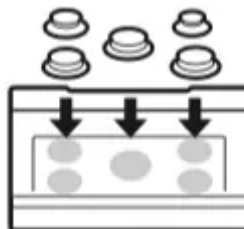

Make sure that all grates are properly placed before using the burner.

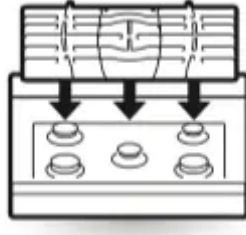

CAUTION

Do not operate the burner for an extended period of time without cookware on the grate.

The finish on the grate may chip without cookware to absorb the heat.

Make sure the burners and grates are cool before touching them, or placing a pot holder, cleaning cloth, or other materials on them.

Touching grates before they cool down may cause burns.

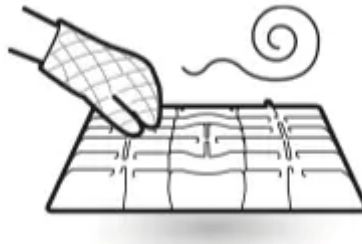

CAUTION

WHAT TO DO IF YOU SMELL GAS

- Open windows.
- Do not try to light any appliance.
- Do not touch any electrical switch.
- Do not use any phone in your building.
- Immediately call your gas supplier from a neighbor's phone. Follow the gas supplier's instructions.
- If you cannot reach your gas supplier, call the fire department.

NOTE

Electric spark igniters from the burners cause a clicking noise. All the spark igniters on the cooktop will activate when igniting just one burner.

Burner Locations

Your gas range cooktop has four or five sealed gas burners, depending on the model. These can be assembled and separated. Follow the guide below.

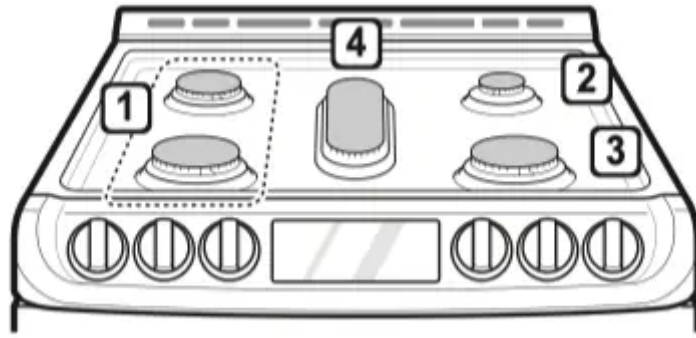

1. Medium and Large Burners

The medium and large burners are the primary burners for most cooking. These general purpose burners can be turned down from Hi to Lo to suit a wide range of cooking needs.

2. Small Burner

The smallest burner is used for delicate foods such as sauces or foods that require low heat for a long cooking time.

3. Extra Large Burner

The extra large burner is the maximum output burner. Like the other four burners, it can be turned down from Hi to Lo for a wide range of cooking applications. This burner is also designed to quickly bring large amounts of liquid to a boil. It can be used with cookware 10 inches or larger in diameter.

4. Oval Burner

The center, oval burner is for use with a griddle or oval pots.

Using the Gas Surface Burners

1. Be sure that all of the surface burners and grates are placed in the correct positions.
2. Place cookware on the grate.
3. Push the control knob and turn to the Lite position.

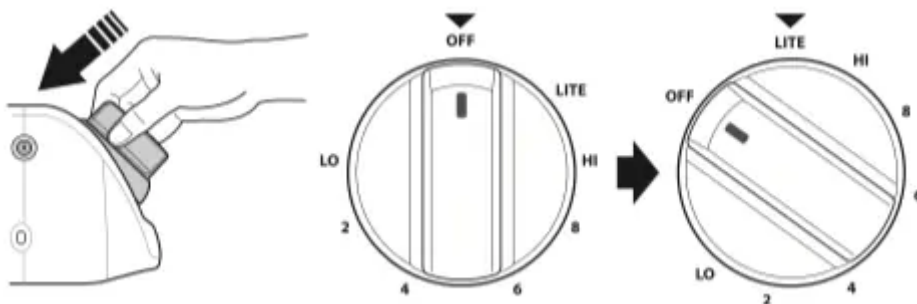

The electric spark ignition system makes a clicking noise.

4. Turn the control knob to control the flame size.

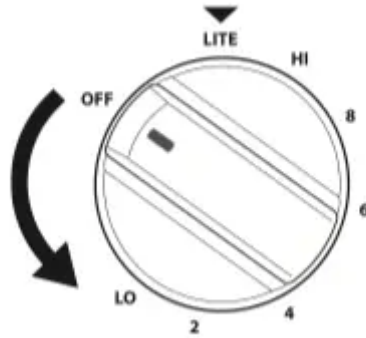

CAUTION

Do not attempt to disassemble or clean around any burner while another burner is on. All the burners spark when any burner is turned to Lite. An electric shock may result causing you to knock over hot cookware.

Setting the Flame Size

Watch the flame, not the knob, as you reduce heat. Match the flame size on a gas burner to the cookware being used for fastest heating.

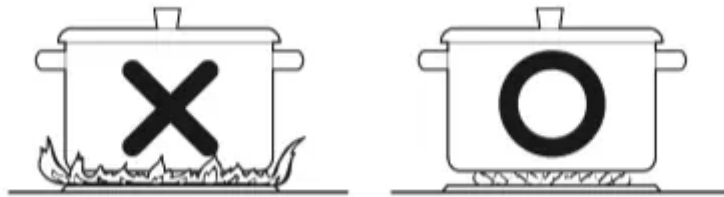

CAUTION

Never let the flames extend up the sides of the cookware.

NOTE

- The flames on the surface burners may burn yellow in the presence of high humidity, such as a rainy day or a nearby humidifier.
- After LP gas conversion, flames can be bigger than normal when you put a pot on the surface burner.

In Case of Power Failure

In case of a power failure, you can light the gas surface burners on your range with a match.

Surface burners in use when an electrical power failure occurs will continue to operate normally.

1. Hold a lit match to the burner, then push in the control knob.
2. Turn the control knob to the Lo position.

CAUTION

Use extreme caution when lighting burners with a match. It can cause burns and other damage.

Range-Top Cookware

Aluminum	Medium-weight cookware is recommended because it heats quickly and evenly. Most foods brown evenly in an aluminum skillet. Use saucepans with tight fitting lids when cooking with minimum amounts of water.
Cast-Iron	If heated slowly, most skillets will give satisfactory results.
Stainless Steel	This metal alone has poor heating properties and is usually combined with copper, aluminum or other metals for improved heat distribution. Combination metal skillets work satisfactorily if they are used with medium heat as the manufacturer recommends.
Enamelware	Under some conditions, the enamel of this cookware may melt. Follow cookware manufacturer's recommendations for cooking methods.
Glass	There are two types of glass cookware. Those for oven use only and those for top-of-range cooking.
Heatproof Glass Ceramic	Can be used for either surface or oven cooking. It conducts heat very slowly and cools very slowly. Check cookware manufacturer's directions to be sure it can be used on gas ranges.

Using a Wok

If using a wok, use a 14-inch or smaller flat-bottomed wok. Make sure that the wok bottom sits flat on the grate.

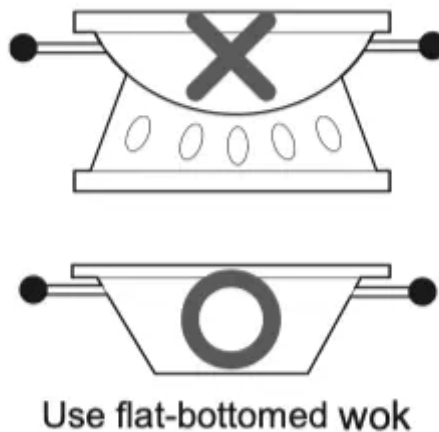

CAUTION

Do not use a wok support ring. Placing the ring over the burner or grate may cause the burner to work improperly, resulting in carbon monoxide levels above allowable standards. This can be hazardous to your health.

Using Stove-Top Grills

Do not place stove-top grills on the burner.



CAUTION

Do not use stove top grills on the surface burners. Using a stove top grill on the surface burner will cause incomplete combustion and can result in exposure to carbon monoxide levels above allowable current standards. This can be a health hazard.

Using the Griddle

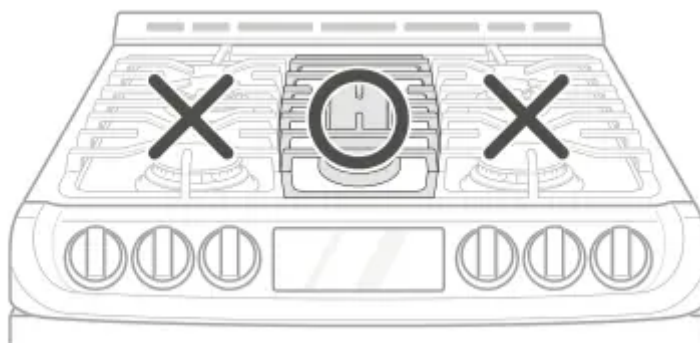

The non-stick coated griddle provides an extra-large cooking surface for meats, pancakes or other food usually prepared in a frying pan or skillet.

NOTE

It is normal for the griddle to become discolored over time.

How to Place the Griddle: The griddle can only be used with the center burner. The griddle must be properly placed on the center grate, as shown below.

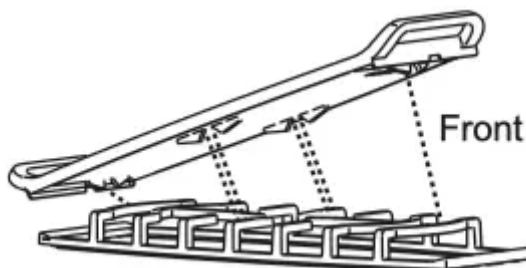

CAUTION

- Do not remove the center grate when using the griddle.
- Do not remove the griddle plate until the cooktop grates, surfaces and griddle plate have completely cooled.
- The griddle plate on the cooktop may become very hot when using the cooktop, oven or broiler systems. Always use oven mitts when placing or removing the griddle plate.

Preheat the griddle according to the guide below and adjust for the desired setting.

Type of Food	Preheat Conditions	Cook Setting
Warming Tortillas	-	5 (MED)
Pancakes	HI 5 min.	HI
Hamburgers	HI 5 min.	HI
Fried Eggs	HI 5 min.	HI
Bacon	HI 5 min.	HI
Breakfast Sausage Links	HI 5 min.	HI
Hot Sandwiches	HI 5 min.	HI

NOTE

When cooking on the griddle for an extended period, adjust the griddle temperature settings as the griddle retains heat.

IMPORTANT NOTES

- Avoid cooking extremely greasy foods as grease spillover can occur.
- The griddle can become hot when surrounding burners are in use.
- Do not overheat the griddle. This can damage the nonstick coating.
- Do not use metal utensils that can damage the griddle surface. Do not use the griddle as a cutting board.
- Do not place or store items on the griddle.

The Oven

Before Use

Read all instructions before using.

Make sure the electrical power cord and the gas valve are properly connected.

Confirm the correct usage of the range for the type of food you will cook.

Make sure you know how to use the oven (temperature setting, time setting and recipe) for best results.

CAUTION

WHAT TO DO IF YOU SMELL GAS

- Open windows.
- Do not try to light any appliance.
- Do not touch any electrical switch.
- Do not use any phone in your building.
- Immediately call your gas supplier from a neighbor's phone. Follow the gas supplier's instructions.
- If you cannot reach your gas supplier, call the fire department.

Choose the upper or lower oven for proper cooking.

Use the upper oven to cook a small amount of food.

NOTE

If using an oven thermometer in the oven cavity, temperatures may differ from the actual set oven temperature with all modes.

In case of power failure, do not use the oven.

The oven and broiler cannot be used during a power outage. If the oven is in use when a power failure occurs, the oven burner shuts off and cannot be re-lit until power is restored. Once power is restored, you will need to reset the oven (or Broil function).

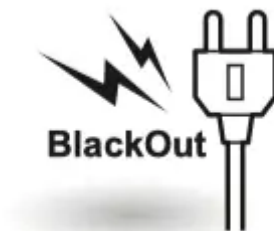

CAUTION

Do not attempt to operate the electric ignition during an electrical power failure.

Do not block, touch or place items around the oven vent during cooking.

Your oven is vented through ducts at the center above the burner grate. Do not block the oven vent when cooking to allow for proper air flow. Do not touch vent openings or nearby surfaces during any cooking operation.

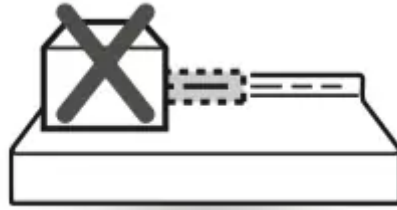

CAUTION

- Do not place plastic or flammable items on the cooktop. They may melt or ignite if left too close to the vent.
- Do not place closed containers on the cooktop. The pressure in closed containers may increase, which may cause them to burst.
- Metal items will become very hot if they are left on the cooktop, and could cause burns.
- Handles of pots and pans on the cooktop may become hot if left too close to the vent.

Do not cover racks or oven bottom with aluminum foil.



You may see condensation on the oven door glass.

As the oven heats up, the heated air in the oven may cause condensation to appear on the oven door glass. These water drops are harmless and will evaporate as the oven continues to heat up.

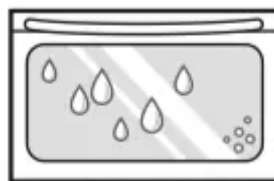

Control Panel Overview

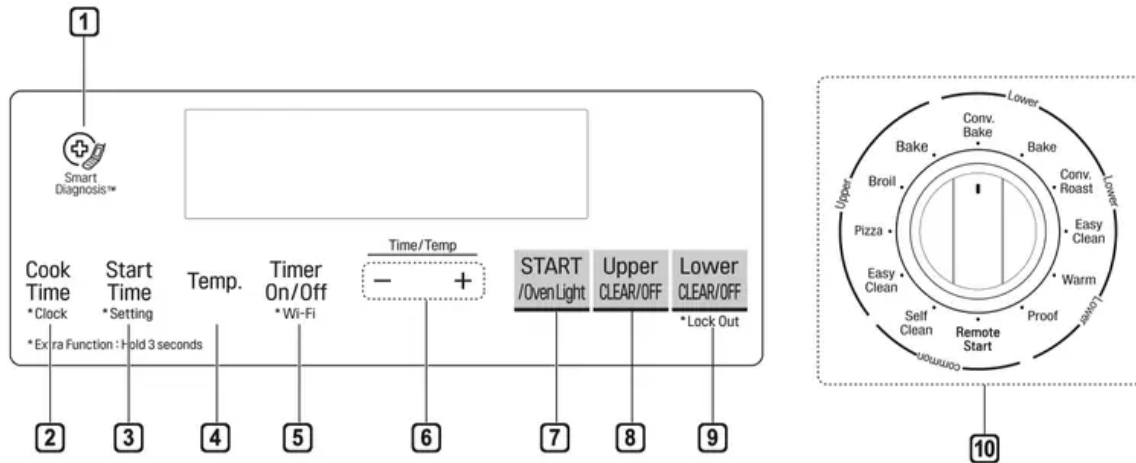

1. Smart Diagnosis™

Use during the Smart Diagnosis feature.

2. Cook Time / Clock

- Press the button to set the desired amount of time for food to cook. The oven shuts off when the set cooking time runs out.
- Press and hold button for three seconds to set the time of day.

3. Start Time / Setting

- Press the button to set the delayed timed cook. The oven starts at the set time.
- Press and hold button for three seconds to select and adjust oven settings.

4. Temp.

- Press the button to change the oven or meat probe temperature during cooking.

5. Timer On/Off / Wi-Fi

- Press the button to set or cancel automatic timer.
- Press and hold button for three seconds to connect to Wi-Fi network.

6. - / +

Press the plus button to increase cooking time or oven temperature.

Press the minus button to decrease cooking time or oven temperature.

7. START / Oven Light

- Press the button to start all oven features.
- Press the button to manually turn the oven light on/ off.

8. Upper CLEAR/OFF

Press the button to end all upper oven features.

9. Lower CLEAR/OFF / Lock Out

- Press the button to end all lower oven feature.
- Press and hold button for three seconds to lock the door and control panel.

10. Oven Mode Knob

Turn the knob to select oven operating mode.

Changing Oven Settings

Clock

The clock must be set to the correct time of day in order for the automatic oven timing functions to work properly.

1. Press and hold Cook Time for three seconds. CLO shows in the display.
2. Press plus(+) or minus(-) to select the desired time. Plus(+) to increase the time and minus(-) to decrease the time.
3. Press Start to enter the time and start the clock.

NOTE

- The time of day cannot be changed during a timed baking or self-clean cycle.
- If no other keys are touched within 25 seconds of touching Clock, the display reverts to the original setting.
- If the display time is blinking, there may have been a power failure. Reset the time.

Oven Light

The interior oven light automatically turns on when the door is opened. Touch Light to manually turn the oven light on.

NOTE

The oven light cannot be turned on if the Self Clean function is active.

Minimum & Maximum Default Settings

All of the features listed have a minimum and a maximum time or temperature setting that can be entered into the control. A beep sounds each time a control key is touched.

Two short tones sound if the entry of the temperature or time is below the minimum or above the maximum setting for the feature.

Feature		min. Temp. / Time	max. Temp. / Time	Default
Clock	12 Hr.	1:00 Hr. / min.	12:59 Hr. / min.	
	24 Hr.	0:00 Hr. / min.	23:59 Hr. / min.	
Timer	12 Hr.	0:10 min. / sec.	11:59 Hr. / min.	
	24 Hr.	0:10 min. / sec.	11:59 Hr. / min.	
Cook Time	12 Hr.	0:01 Hr. / min.	11:59 Hr. / min.	
	24 Hr.	0:01 Hr. / min.	11:59 Hr. / min.	
Conv. Bake		300 °F / 150 °C	550 °F / 285 °C	350 °F (*325 °F)/ 12 Hr.
Conv. Roast		300 °F / 150 °C	550 °F / 285 °C	350 °F (*325 °F)/ 12 Hr.
Broil		Lo 300 °F / 150 °C	Hi 400 °F / 204 °C	Hi / 3 Hr.
Bake		170 °F / 80 °C	550 °F / 285 °C	350 °F / 12 Hr.
Proof				12 Hr.
Pizza				12 Hr.
Warm				3 Hr.
Self Clean		2 Hr.	4 Hr.	3 Hr.
EasyClean[®]				15 min. (Upper)
				10 min. (Lower)



* Using Auto Conversion

- Default cook mode times are without setting cook time.

Timer On/Off

The Lower Timer On/Off serves as an extra timer in the kitchen that beeps when the set time has run out. It does not start or stop cooking.

The Timer On/Off feature can be used during any of the oven control functions.

Setting the Timer

1. Press Timer On/Off. 0:00 with HR inside it appears and Timer flashes in the display.
2. Press plus(+) or minus(-) to select the desired time. Plus(+) increases the time and minus(-) decreases the time.
3. Press Timer On/Off or Start to start the Timer. The remaining time countdown appears in the display.
4. When the set time runs out, End shows in the display. The indicator tones sound every 15 seconds until Timer On/Off is pressed.

NOTE

- If the remaining time is not in the display, recall the remaining time by pressing Timer On/Off.
- Press Timer On/Off twice to set the time in minutes and seconds.
- Press Timer On/Off once to set the time in hours and minutes.

Cancelling the Timer

1. Press Timer On/Off once. The display returns to the time of day.

Wi-Fi

The Wi-Fi button is used to connect the appliance to a home Wi-Fi network.

1. Press Upper CLEAR/OFF and Lower CLEAR/ OFF.
2. Press and hold Timer On/Off for 3 seconds.
3. The power-on chime sounds, Set appears in the display, and the Wi-Fi icon () blinks.
4. Register the appliance on the Wi-Fi network using the smart phone app. (See page 40.)
5. To disconnect the appliance from the network, delete it from the registered appliances in the app.

Settings

Press and hold Start Time for three seconds. Then press the Start Time key repeatedly to toggle through and change oven settings.

The Setting key allows you to:

- set the hour mode on the clock (12 or 24 hours)
- enable/disable convection auto conversion
- adjust the oven temperature
- activate/deactivate the preheating alarm light
- set the beeper volume
- switch the temperature scale between Fahrenheit and Celsius

Setting the Hour Mode

The control is set to use a 12-hour clock. To reset the clock to 24-hour mode, follow the steps below.

1. Press and hold Start Time for three seconds.
2. Press plus(+) or minus(-) to set the desired hour mode on the clock.
3. Press Start to accept the desired change.

Setting Convection Auto Conversion

When Conv. Bake and Conv. roast are selected, Convection Auto Conversion automatically converts the standard recipe temperature entered to a convection temperature by subtracting 25 °F / 14 °C. This auto-converted temperature shows on the display. For example, select Conv. Bake, enter 350 °F, and 325 °F shows on the display after preheat.

Convection Auto Conversion is enabled by default. To change the setting, follow these instructions.

1. Press and hold Start Time for three seconds. Then press Start Time repeatedly until Auto appears in the display
2. Press plus(+) or minus(-) to enable or disable the feature.
3. Press Start to accept the change.

Adjusting the Oven Temperature

Your new oven may cook differently from the one it replaced. Use your new oven for a few weeks to become more familiar with it before changing the temperature settings. If after familiarizing yourself with the new oven, you still think that it is too hot or too cold, you can adjust the oven thermostat yourself.

NOTE

To begin, either raise or lower the thermostat 15 °F (8 °C). Try the oven with the new setting. If the oven still needs adjustment, raise or lower the thermostat again, using the first adjustment as a gauge. For example, if the adjustment was too much, raise or lower the thermostat 10 °F (5 °C). If

the adjustment was not enough, raise or lower the thermostat 20 °F (12 °C). Proceed in this way until the oven is adjusted to your satisfaction.

1. Press and hold Start Time for three seconds. Then press Start Time repeatedly until U_AJ or L_AJ appears in the display.
2. To increase the temperature, press plus (+) until the desired amount appears in the display. To decrease the temperature, press minus (-) until the desired amount appears in the display.
3. Press Start to accept the change.

NOTE

- This adjustment does not affect the broiling or Self Clean temperatures. The adjustment is retained in memory after a power failure. The oven temperature can be increased (+) or decreased (-) as much as 35 °F or 19 °C.
- Once the temperature is increased or decreased, the display shows the adjusted temperature until it is readjusted.

Turning the Preheat Alarm Light On/Off

When the oven reaches its set-temperature, the preheating alarm light flashes 5 times or until the oven door is opened.

You can activate or deactivate the preheating alarm light.

1. Press and hold Start Time for three seconds. Then press Start Time repeatedly until PrE appears in the display.
2. Press plus(+) or minus(-) to turn the function on/off.
3. Press Start to accept the change.

Adjusting the Beeper Volume

1. Press and hold Start Time for three seconds. Then press Start Time repeatedly until BEEP appears in the display.
2. Press plus(+) or minus(-) to select Hi, Lo or Off.
3. Press Start to accept the change.

Selecting Fahrenheit or Celsius

Set the oven temperature display to show either Fahrenheit (°F) or Celsius (°C) units. The oven defaults to Fahrenheit unless changed by the user.

1. Press and hold Start Time for three seconds. Then press Start Time repeatedly until Unit appears in the display.
2. Press plus(+) or minus(-) to select F(Fahrenheit) or C(Celsius).

3. Press Start to accept the change.

Lock Out

The Lock Out feature automatically locks the oven door and prevents most oven controls from being turned on. It does not disable the clock, timer or the interior oven light.

1. Press and hold Lower CLEAR/OFF for three seconds.
2. The lock melody sounds, Loc appears in the display, and the lock icon blinks in the display.
3. Once the oven door is locked, the lock indicator stops blinking and remains on.
4. To deactivate the Lock Out feature, press and hold Lower CLEAR/OFF for three seconds. The unlock melody sounds and the door and the controls unlock.

Start Time (Delayed Timed Cook)

The automatic timer of the Delayed Timed Cook function turns the oven on and off at the time you select. This feature can be used with the Bake, Conv. Bake and Conv. roast modes.

Setting a Delayed Timed Cook

For example, to bake at 300 °F and delay the start of baking until 4:30, first set the clock for the correct time of day.

1. Turn the oven mode knob to select the Bake mode. 350 °F appears in the display.
2. Set the temperature: press minus(-) until 300 °F appears in the display.
3. Press Cook Time and press plus(+) or minus(-) to set the baking time.
4. Press Start Time.
5. Set the start time: press plus(+) until 4:30 appears in the display.
6. Press Start. A short beep sounds and Timed Delay and the start time appear in the display. The oven begins baking at the set start time.

NOTE

- To cancel the Delayed Timed Cook function, Press CLEAR/OFF at any time.
- To change the cooking time, repeat step 3 and press Start.
- If the oven clock is set as a 12-hour clock, you can delay the cook time for 12 hours. If the oven clock is set as a 24-hour clock, you can delay the cook time for 24 hours.

The oven will continue to cook for the set amount of time and then turn off automatically. When the cooking time has elapsed:

- End and the time of day show in the display.
- The cook-end indicator tone sounds every 60 seconds until CLEAR/OFF is pressed.

CAUTION

- Use the automatic timer when cooking cured or frozen meats and most fruits and vegetables. Foods that can easily spoil, such as milk, eggs, fish, meat or poultry, should be chilled in the refrigerator. Even when chilled, they should not stand in the oven for more than 1 hour before cooking begins, and should be removed promptly when cooking is completed.
- Eating spoiled food can result in sickness from food poisoning.

Cook Time (Timed Cook)

Set the oven to cook for a specific length of time using the Timed Cook feature. This feature can only be used with the Bake, Conv. Bake and Conv. roast modes.

Setting the Cook Time Function

For example, to bake at 300 °F for 30 minutes, first set the clock to the correct time of day.

1. Turn the oven mode knob to select the Bake mode. 350 °F appears in the display.
2. Set the oven temperature. For this example, press minus(-) until 300 °F appears in the display.
3. Press Cook Time. Timed flashes in the display. Bake, 0:00 and 300 °F appear in the display.
4. Set the baking time: press plus(+) until 30:00 appears in the display. The baking time can be set for any amount of time between 1 minute and 11 hours and 59 minutes.
5. Press Start.

The oven will continue to cook for the set amount of time and then turn off automatically. When the cooking time has elapsed:

- End and the time of day show in the display.
- The cook end indicator tone sounds every 60 seconds until CLEAR/OFF is pressed.

Changing the Cook Time during Cooking

For example, to change the cook time from 30 minutes to 1 hour and 30 minutes, do the following.

1. Press Cook Time.
2. Change the baking time: press plus(+) until 1 hour and 30 minutes appears in the display.
3. Press Start to accept the change.

Removing and replacing the Oven racks

CAUTION

- Adjust the oven racks before turning the oven on to prevent burns.

- Do not cover the racks with aluminum foil, or any other material, or place anything on the bottom of the oven. Doing so will result in poor baking performance and may damage the oven bottom.
- Only arrange oven racks when the oven is cool.

Removing racks

1. While wearing oven mitts, grasp the oven rack*.
2. Pull the rack straight out until it stops.
3. Lift up the front of the rack.
4. Pull out the rack.

* When possible, adjust oven racks before using the oven. Always wear oven mitts if adjusting racks while the oven is on.

Replacing racks

1. While wearing oven mitts, place the end of the rack on the support*
2. Tilt the front end of the rack up.
3. Push the rack in.
4. Check that the rack is properly in place.

*When possible, adjust oven racks before using the oven. Always wear oven mitts if adjusting racks while the oven is on.

Recommended Baking and roasting Guide

- Center pans on racks for best baking results. If baking with more than one pan, place the pans so that each one has at least 1" to 1 1 / 2 " of air space around it. Do not allow pans to touch the walls of the oven.
- If cooking on a single rack, place the heavy rack in position 1 in the upper oven and position 1 in the lower oven. Center the cookware as shown in the single rack image.
- If cooking on multiple racks in the lower oven, place a heavy rack in position 1 and position 4. Center the cookware as shown in the multiple rack image.

Multiple rack baking

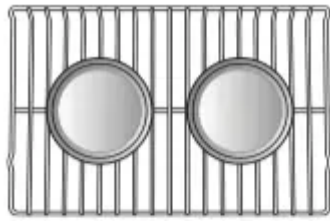

Rack
(Position 4)

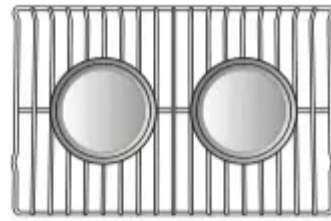

Rack
(Position 1)

Single rack baking

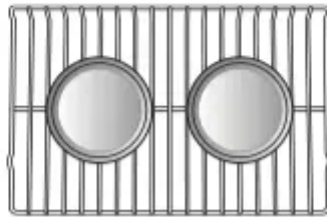

Rack

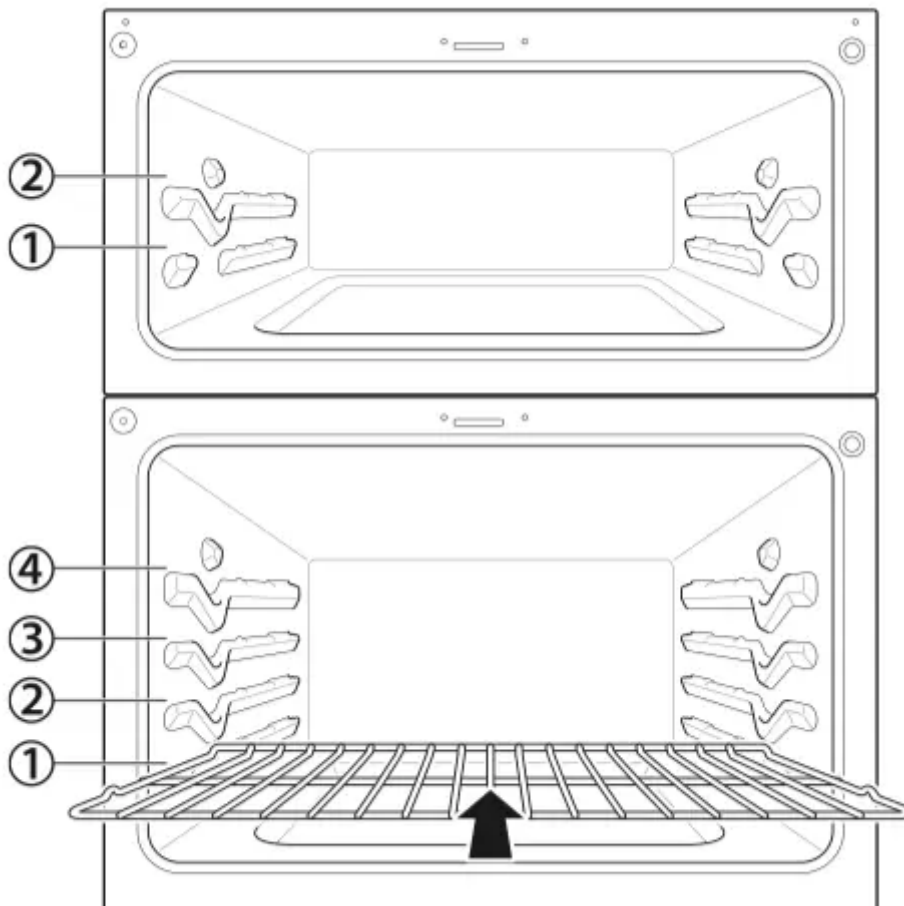

Bake



Bake is used to prepare foods such as pastries, breads and casseroles. The oven can be programmed to bake at any temperature from 170 °F (80 °C) to 550 °F (285 °C). The default temperature is 350 °F (175 °C).

Setting the Bake Function (example, 375 °F)

1. Turn the oven mode knob to select Bake.
2. Set the oven temperature: for example, press plus(+) until 375 °F appears in the display.
3. Press Start. The oven starts to preheat.

As the oven preheats, the temperature is displayed and rises in 5-degree increments. Once the oven reaches the set temperature, a tone sounds and the oven light blinks on and off.

4. When cooking is complete, press CLEAR/OFF.
5. Remove food from the oven.

NOTE

- It is normal for the convection fan to operate periodically throughout a normal bake cycle in the oven. This is to ensure even baking results.
- The convection fan may continue to run for a short time after the oven is turned off.

Baking Chart

This chart is only for reference and can be used for both the upper and lower ovens. Adjust the cook time according to your recipe.

Food	Oven Temperature	Rack position	
		Upper Oven	Lower Oven
Cakes - Layer cake - Bundt cake - Cupcakes - Pound cake - Carrot cake (from scratch)	350 °F (175 °C) 350 °F (175 °C) 350 °F (175 °C) 350 °F (175 °C) 350 °F (175 °C)	1 1 1 1 1	1 1 1 1
Cookies - Sugar cookies - Chocolate chip - Brownies	350 °F (175 °C) 350 °F (175 °C) 350 °F (175 °C)	1 1 1	1 1 1
Pizza - Rising - Frozen - Fresh	400 °F (204 °C) 400 °F (204 °C) 425 °F (218 °C)	2 2 2	1 1 1
Breads - Biscuits (canned) - Biscuits (from scratch) - Muffins	350 °F (175 °C) 425 °F (218 °C) 425 °F (218 °C)	1 1 1	1 1 1



Fruits and Vegetables - Apples (baked) - Potatoes (baked)	375 °F (190 °C) 425 °F (218 °C)	1	1
		1	1

NOTE

- Because the oven temperature cycles, an oven thermometer placed in the oven cavity may not show the same temperature that is set on the oven.
- It is normal for the convection fan to run while preheating during a regular bake cycle.
- The convection fan motor may run periodically during a regular bake cycle.
- The bake burner turns off if the door is left open during baking. If the door is left open for longer than 30 seconds during baking, the bake burner turns off. The bake burner turns back on automatically once the door is closed.

Convection Mode

The convection system uses a fan to circulate heat evenly within the oven. This improves heat distribution and allows for even cooking and excellent results, especially when using multiple racks. Convection cooking can also shorten cooking times.

Convection Bake

Setting the Conv. Bake Function (example: to Conv. Bake at 350°F)

1. Turn the oven mode knob to select Conv. Bake.
2. Set the oven temperature: press plus(+) until 375 °F appears in the display.

NOTE

- The convection cooking modes automatically reduce the oven temperature by 25 °F (14 °C). The display shows the changed temperature. This feature is called auto conversion. The range comes with this feature enabled. To disable the auto conversion feature, see Setting Convection Auto Conversion, page 28.
 - The oven fan runs while convection baking. If the door is left open for longer than 30 seconds during baking, the fan stops and the bake burner turns off.
3. Press Start. The display shows Conv. Bake and the converted temperature starting at 100 °F. As the oven preheats, the displayed temperature will increase in 5-degree increments.
 4. Once the oven reaches the desired temperature, a tone sounds and the oven light blinks on and off. The display shows the auto converted oven temperature: 350 °F, Conv. Bake and .
 5. Place food in oven.

- Convection Bake cooks faster and more evenly when cooking foods like cookies, biscuits, rolls, or other baked goods on a single rack. Cookies, muffins, and biscuits will have very good results when using multiple racks.
- Multiple rack cooking may slightly increase times for some foods, but the overall time is reduced.
- Convection Bake gives excellent results for quick breads and yeast breads of all kinds, and breads and pastries brown more evenly.
- Do not use Convection Bake for delicate items like custards, souffles, or cheesecakes, which may be disturbed by the convection fan.

Convection Baking Chart

If auto conversion is disabled, reduce standard recipe temperature by 25 °F (14 °C) for Convection Bake. Temperatures have been adjusted in this chart. Multi-rack cooking may slightly increase cook times for some foods, but the overall time is reduced. This chart is only for reference. Adjust cooking time according to your preference.

Food	Oven Temperature (converted)	Rack position
Cakes - Layer cakes - Bundt cakes	325 °F (161 °C) 325 °F (161 °C)	1 1
Cakes, Specialty - Popovers - Cupcakes - Pound cakes	400 °F (204 °C) 325 °F (161 °C) 325 °F (161 °C)	1 1 1
Cookies - Sugar cookies - Chocolate chips - Brownies	325 °F (161 °C) 325 °F (161 °C) 325 °F (161 °C)	1 1 1
Pizza - Frozen - Fresh	375 °F (190 °C) 385 °F (196 °C)	1 1
Breads - Biscuit, canned - Biscuit, from scratch - Muffins - White bread, loaf	325 °F (161 °C) 350 °F (175 °C) 375 °F (190 °C) 400 °F (204 °C)	1 1 1 1
Pastry Crust - From scratch - Refrigerator	400 °F (204 °C) 400 °F (204 °C)	1 1
Desserts	350 °F (175 °C)	1



<p>- Fruit crisps and cobblers, from scratch</p> <p>- Pies, from scratch, 2 crust fruit</p>	<p>350 °F (175 °C)</p>	<p>1</p>
---	------------------------	----------

Cookware for Convection Cooking

Any cookware safe for use in a conventional oven will work in a convection oven. But for best results, keep the following in mind.

- Make sure pans don't touch the oven walls when centered on the racks. Use cookware that leaves room for air circulation in the oven for best results when convection cooking.
- Leave space between pans. Make sure pans don't touch each other or the oven walls.
- Do not use pans with high sides. Use flat pans with no sides for cookies or biscuits. Use a pan with low sides for oven-baked chicken.
- Metal pans heat the fastest. Heat-resistant paper and plastic containers that are recommended for use in regular ovens can be used in convection ovens. Glass and ceramic pans can also be used. However, metal pans heat the fastest and are recommended for convection cooking.
- Food cooked on pans with dark or matte finishes cooks faster than food on pans with shiny finishes.
- Use the pan size recommended in the recipe.

NOTE

- Some frozen foods have been developed to use commercial convection ovens. For best results in this oven, preheat the oven and use the temperature recommended on the packaging.
- If a food manufacturer gives specific convection cooking instructions, remember that convection autoconversion will reduce the set temperature by 25 °F (14 °C). If autoconversion is enabled, add 25 °F (14 °C) when setting the temperature to get a resulting converted temperature which matches the recipe.

Convection roast

The Convection Roast feature is designed to give optimum roasting performance. Convection Roast combines cooking with the convection fan to roast meats and poultry. The heated air circulates around the food from all sides, sealing in juices and flavors. Food cooked in this manner is crispy brown on the outside while staying moist on the inside.

Setting the Conv. roast Function (example: to Conv. roast at 350°F)

1. Turn the oven mode knob to select Conv. roast.
2. Set the oven temperature: press plus(+) until 375 °F appears in the display.

NOTE

The convection cooking modes automatically reduce the oven temperature by 25 °F (14 °C). The display shows the changed temperature. This feature is called auto conversion. The range comes with this feature enabled. To disable the auto conversion feature, see Setting Convection Auto Conversion, page 28.

3. Press Start. The display shows Conv. roast and the changing temperature starting at 100 °F. As the oven preheats, the displayed temperature will increase in 5-degree increments.
4. Once the oven reaches the desired temperature, a tone sounds and the oven light flashes on and off. The display shows the auto converted oven temperature: 350 °F, Conv. roast and .
5. Place food in oven.

Broil

This oven is designed for closed-door broiling. Broil uses an intense heat radiation from the upper gas burner.

The Broil function works best when broiling thin, tender cuts of meat (1" or less), poultry or fish.

CAUTION

- Do not use a broiler pan without a grid. The oil can cause a grease fire.
- Do not cover the grid and broiler pan with aluminum foil. Doing so will cause a fire.
- Always use a broiler pan and grid for excess fat and grease drainage. This will help to reduce splatter, smoke, and flare-ups.
- Never use a broiler pan that is not thoroughly cleaned and at room temperature. If your broiler pan is damaged, warped, or has heavy permanent soiling, consider replacing it to reduce the amount of smoke you experience during broiling.

NOTE

- Use Lo broil to broil foods such as poultry and thick cuts of meat.
- Remove the pan from the oven to cool down for easy cleaning.
- For best results, use a pan designed for broiling, as shown below. The broiler pan will catch grease spills and the grid will help prevent grease splatters.

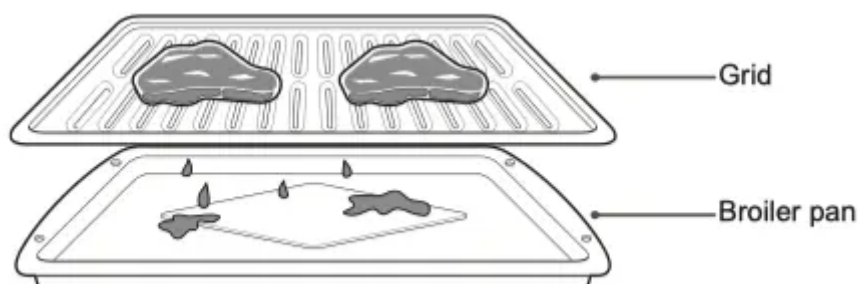

When broiling in the upper oven, use the standard rack provided for better cooking results.



CAUTION

Take care when sliding the gliding rack in and out. It lies lower in the cavity and passes closer to hot surfaces that can cause burns. Always wear oven mitts when handling racks.

Setting the Oven to Broil

1. Turn the oven mode knob to select Broil. Press plus(+) or minus(-) to select Hi or Lo.
2. Press Start.
3. Allow the broiler to preheat for five minutes.
4. Place food in the oven.
5. Close the oven door. The oven door must be closed during broiling.

WARNING

When using your broiler, the temperature inside the oven is extremely hot. Take care to avoid possible burns by:

- Keeping the door closed when broiling
- Always wearing oven mitts when inserting/ removing food items

Improper use of the broiler may result in excessive smoke or a grease fire. Improper use conditions include, but are not limited to:

- Setting the broiler to a higher power level than recommended.
- Using dirty/greasy broiler pans.
- Broiling beyond recommended cooking times.

NOTE

- This range is designed for closed-door broiling. Close the door to set the Broil function. If the door is open, the Broil function cannot be set and door appears on the display. Close the door and reset the Broil function. Opening the door turns off the broil burner during broiling. If the door is opened during broiling, the broil burner turns off after five seconds. The broiler turns back on automatically once the door is closed.

6. When broiling is finished, touch Upper CLEAR/ OFF.

NOTE

During any Broil function, it is normal for the broiler to cycle on and off. The igniter for the broil burner on the ceiling of the oven glows orange periodically during normal broil operation.

Recommended Broiling Guide

The size, weight, thickness, starting temperature, and your preference of doneness will affect broiling times. This guide is based on meats at refrigerator temperature. For best results when broiling, use a pan designed for broiling.

Food	Quantity and/or Thickness	Upper oven			Comments
		Rack Position	First Side (minutes)	Second Side (minutes)	
Ground Beef Well done	1 lb. (4 patties) 1/2 to 3/4 " thick	2	5-7	3-5	Space evenly. Up to 8 patties may be broiled at once.
Beef Steaks Rare Medium Well Done Rare Medium Well Done	1" thick 1 to 1 1/2 lbs.	2	4-6	2-3	Steaks less than 1" thick cook through before browning. Pan frying is recommended. Slash fat.
		2	5-7	3-4	
		2	6-8	4-5	
	1 1/2" thick 2 to 2 1/2 lbs.	1	8	3-4	
		2	9	4-5	
		1	10	5-6	
Chicken	1 whole cut up, 2 to 2 1/2 lbs., split lengthwise	1	8-10	5-7	Broil skin-side-down first.
	2 breasts	1	8-9	5-6	
Fish Fillets	1 1/4 to 1/2 " thick	1	5	2-4	Handle and turn very carefully. Brush with lemon butter before and during cooking, if desired.



Ham Slices (precooked)	1 1/2" thick	1	6-7	2-3	Increase time 5 to 10 minutes per side for 1 1/2" thick or home-cured ham.
Pork chops Well Done	1 (1/2" thick)	1	4-6	3-5	Slash fat.
	2 (1" thick) about 1lb.	1	7-9	5-7	
Lamb Chops Medium Well Done Medium Well done	2 (1" thick) about 10 to 12 oz.	1	7-8	2-3	Slash fat.
		1	8-9	3-4	
	2 (1/2" thick) about 1lb.	1	6-7	2-3	
		1	7-8	3-4	
Salmon Steaks	2 (1" thick)	1	7-9	3-5	Grease pan. Brush steaks with melted butter.
	4 (1" thick) about 1lb.	1	8-10	3-5	
Bread	1 1/2" thick	1	0.5-2	0.5-2	

- This guide is only for reference. Adjust cook time according to your preference.

NOTE

The USDA advises that consuming raw or undercooked fish, meat, or poultry can increase your risk of foodborne illness.

The USDA has indicated the following as safe minimum internal temperatures for consumption:

- Ground beef: 160 °F (71.1 °C)
- Poultry: 165 °F (73.9 °C)

- Beef, veal, pork, or lamb: 145 °F (62.8 °C)
- Fish / Seafood: 145 °F (62.8 °C)

Pizza

This function automatically sets the oven temperature to cook either frozen pizza with regular or rising crust, or freshly made pizza. Simply choose the type of pizza (see chart) and set the desired cook time.

Setting the Oven for Pizza

1. Turn the oven mode knob to select the Pizza mode. P1 appears in the display. Press plus(+) or minus(-) repeatedly to toggle between the P1, P2 and P3 options. (See Pizza Chart below.)
2. Press Start. The oven starts to preheat.

As the oven preheats, the temperature is displayed and rises in 5-degree increments. Once the oven reaches the set temperature, a tone sounds and the oven light blinks on and off.

3. Place pizza in the oven, close the door and set the timer following the suggestions in the chart.
4. When cooking is complete press Upper CLEAR/ OFF.
5. Remove the food from the oven.

NOTE Preheating is necessary for better cooking results. Place the food in the oven after preheating.

Pizza Chart

Display Mode	Item	Rack position		Recommended time (minutes)	
		Upper Oven	Lower Oven	Upper Oven	Lower Oven
P1	Frozen pizza, regular crust	2	2	14-18	10-14
P2	Frozen pizza, rising crust	2	2	17-21	14-18
P3	Fresh Pizza	1	2	18-22	10-14

Warm

This function will maintain an oven temperature of 170 °F. The Warm function will keep cooked food warm for serving up to three hours after cooking has finished. The Warm function may be used without any other cooking operations.

Setting the Warm Function

1. Turn the oven mode knob to select Warm.
2. Press Start.
3. Press Lower CLEAR/OFF at any time to cancel.

NOTE

- The Warm function is intended to keep food warm. Do not use it to cool food down.
- It is normal for the fan to operate during the Warm function (lower oven only).

Proof

This feature maintains a warm oven for rising yeast leavened products before baking.

Setting the Proof Function

1. Use rack position 2 or 3 for proofing.
2. Turn the oven mode knob to select Proof.
3. Press Start.
4. Press Lower CLEAR/OFF when proofing is finished.

NOTE

- To avoid lowering the oven temperature and lengthening proofing time, do not open the oven door unnecessarily. Check bread products early to avoid overproofing.
- Do not use the proofing mode for warming food or keeping food hot. The proofing oven temperature is not hot enough to keep foods at safe temperatures. Use the Warm feature to keep food warm. Proofing does not operate when the oven is above 125 °F. Hot shows in the display.
- It is normal for the fan to operate during the Proof function.

Meat Probe

The meat probe accurately measures the internal temperature of meat, poultry and casseroles. It should not be used during broiling, self clean, warming or proofing. Always unplug and remove the meat probe from the oven when removing food. Before using, insert the probe into the center of the thickest part of the meat or into the inner thigh or breast of poultry, away from fat or bones. Place food in the oven and connect the meat probe to the jack. Keep the probe as far away from heat sources as possible.

Using the Meat Probe

1. Insert the meat probe into the meat.

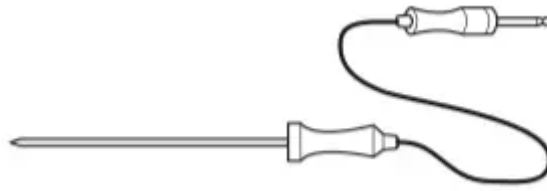

2. Connect the meat probe to the jack.
3. The meat probe icon flashes in the display if the meat probe is properly connected.

Setting the Meat Probe Function (example: to Conv. roast at 350°F with probe temp. 160 °F)

1. Select cook mode. Turn the oven mode knob to select Conv. roast.
2. Set the oven temperature: press plus(+) or minus(-) until 375 °F appears in the display.
3. Press Start.
4. Set the probe temperature: press plus(+) or minus(-) until 160 °F appears in the display.
5. Press Start.

The default probe temperature is 150 °F (65 °C), but can be changed to any temperature between 80 °F (27 °C) and 210 °F (100 °C). The display shows the changing probe temperature. When the set probe temperature is reached, the oven shuts off automatically.

Changing the Probe Temperature while Cooking

1. Press Temp.
2. Set the oven temperature and probe temperature.
3. Press Start.

IMPORTANT NOTE

Press CLEAR/OFF to cancel the Meat Probe function at any time. To avoid breaking the probe, make sure food is completely defrosted before inserting.

CAUTION

- Always use an oven mitt to remove the temperature probe. Do not touch the broil element. Failure to obey this caution can result in severe personal injury.
- To avoid damage to the meat probe, Do not use tongs to pull on the probe when removing it.
- Do not store the meat probe in the oven.

Recommended Probe Temperature Chart

Doneness	Probe Temp.
Beef, Lamb and Veal Rare Medium Rare Medium Well Done	130 °F (54 °C) 140 °F (60 °C) 150 °F (66 °C) 160 °F (71 °C)
Pork Well Done	170 °F (77 °C)
Poultry Breast, Well Done Thigh, Well Done Stuffing, Well Done	170 °F (77 °C) 180 °F (82 °C) 165 °F (74 °C)

Remote Start

If the appliance is registered on a home Wi-Fi network, this function starts preheating and then holds the temperature for up to an hour (including preheating time). If the appliance is not registered on the network, “OFF” appears in the display. Follow the instructions on page 40 to register the appliance on the network.

Set the oven mode knob to the Remote Start position to use the function.

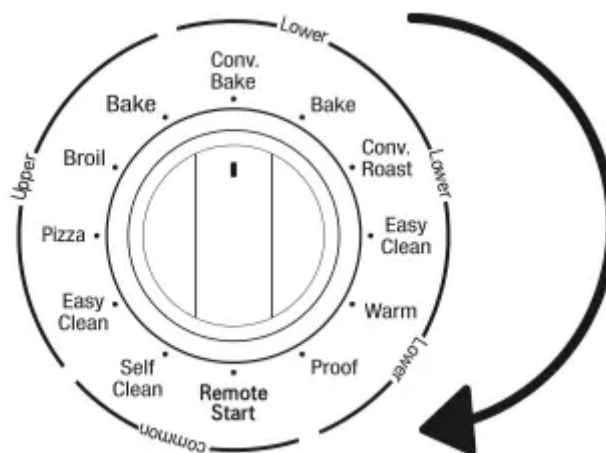

Setting remote Start

1. Open the oven door to make sure the oven is empty and ready for pre-heating. Close the oven door.
2. Within 30 seconds of closing the door, turn the oven mode knob to Remote Start to use the function. If more than 30 seconds passes before you initiate Remote Start, "door" appears in the display. If this occurs, open and close the door and try again.
3. When ON appears in the display, the Remote Start function is ready to use.
4. Follow the directions in the smart phone application to set the cook mode, temperature, and run time (preheating time plus holding time).

NOTE

Do not place food in oven before or during Remote Start run time.

Remote Start is disconnected in the following situations:

- Remote Start is never set up in the smart phone app.
- The Remote Start status is "OFF" or "door".
- Remote Start function can not be started if either oven is in use.
- The Remote Start function cannot be started when the oven door is open. A beep alerts you to shut the door.

MAINTENANCE



CAUTION

- Do not clean this appliance with bleach.
- To prevent burns, wait until the cooktop has cooled down before touching any of its parts.
- Always wear gloves when cleaning the cooktop.

Removing and replacing the Gas Surface Burners

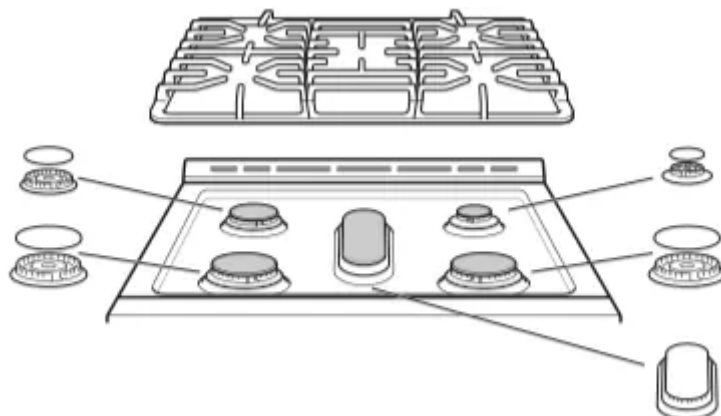
Grates and burner head / cap can be removed for care and cleaning.

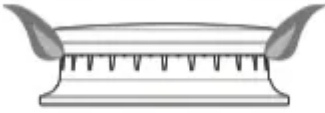

	General burner
Burner cap is properly set.	
Burner cap is NOT properly set.	

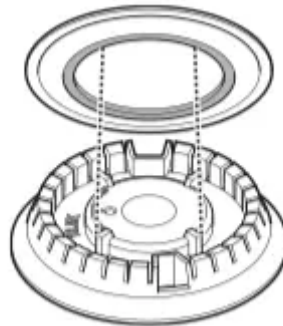

CAUTION

Make sure burner heads and caps are reinstalled properly. They will be stable and rest flat when correctly installed.

Cleaning Burner Heads/Caps

For even and unhampered flame, the slits in the burner heads must be kept clean at all times. The burner heads and caps (and the oval burner head and cap assembly) can be lifted off. Do not attempt to remove the oval burner cap.

- Wash the burner caps in hot soapy water and rinse with clean water. Run water through the oval burner from the bottom stem to flush out debris.
- Use care when cleaning the cooktop. The pointed metal ends on the electrodes could cause injury. Hitting an electrode with a hard object may damage it.
- To remove burnt-on food, soak the burner heads in a solution of mild liquid detergent and hot water for 20–30 minutes. For stubborn stains, use a toothbrush or wire brush.
- The burners will not operate properly if the burner ports or electrodes are clogged or dirty.
- Burner caps and heads should be cleaned routinely, especially after excessive spillover.
- Burners will not light if the cap is removed.

CAUTION

- Do not hit the electrodes with anything hard. Doing so could damage them.
- Do not use steel wool or scouring powders to clean the burners.

After Cleaning the Burner Heads/ Caps

Shake out any excess water and then let the parts dry thoroughly. Placing the oval burner upside down will allow the water to drain out more easily. Replace the burner heads and caps over the electrodes on the cooktop in the correct locations according to their size. Make sure the hole in the burner head is positioned over the electrode.

Burner Grates

The range consists of three separate professionalstyle grates. For maximum stability, these grates should only be used when in their proper position. The two side grates can be interchanged from left to right and front to back. The center grate can be interchanged from front to back.

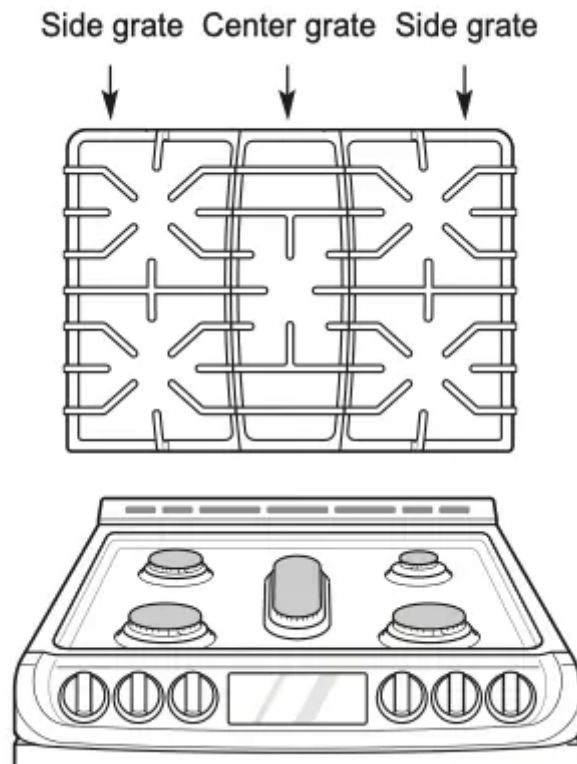

NOTE

Do not operate a burner for an extended period of time without cookware on the grate. The finish on the grate may chip without cookware to absorb the heat.

Cleaning the Burner Grates

CAUTION

- Do not lift the grates out until they have cooled.
- Do not put the grate in the oven during self cleaning mode.
 - Grates should be washed regularly and after spillovers.
 - Wash the grates in hot, soapy water and rinse with clean water.
 - The grates are dishwasher safe.

- After cleaning the grates, let them dry completely and securely position them over the burners.

Cleaning the Cooktop Surface

CAUTION

- To avoid burns, do not clean the cooktop surface until it has cooled.
- Do not lift the cooktop surface. Lifting the cooktop surface can lead to damage and improper operation of the range.
- When water is spilled on the cooktop, wipe up water immediately. If water is left on the cooktop for a long time, discoloration may occur.

Foods with high acid or sugar content may cause a dull spot if allowed to set. Wash and rinse soon after the surface has cooled. For other spills such as oil/ grease spattering, etc., wash with soap and water when the surface has cooled, then rinse and polish with a dry cloth.

Oven Air Vents

Air openings are located at the rear of the cooktop, at the top and bottom of the oven door, and at the bottom of the range.

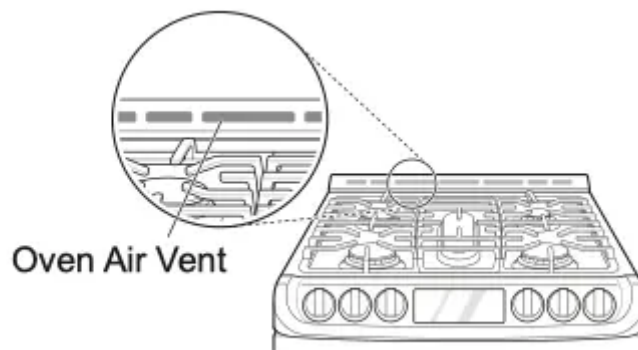

CAUTION

- The edges of the range vent are sharp. Wear gloves when cleaning the range to avoid injury.
- Clean ventilating hoods frequently. Grease should not be allowed to accumulate on the hood or filter.

NOTE

Do not block the vents and air openings of the range. They provide the air inlet and outlet that are necessary for the range to operate properly with correct combustion.

Control Panel

To prevent activating the control panel during cleaning, unplug the range. Clean up splatters with a damp cloth using a glass cleaner. Remove heavier soil with warm, soapy water. Do not use abrasives of any kind.

Front Manifold Panel and Knobs

It is best to clean the manifold panel after each use of the range. For cleaning, use a damp cloth and mild soapy water or a 50/50 solution of vinegar and water. For rinsing, use clean water and polish dry with a soft cloth.

CAUTION

- Do not use abrasive cleansers, strong liquid cleaners, plastic scouring pads or oven cleaners on the manifold panel. Doing so will damage the finish.
- Do not try to bend the knobs by pulling them up or down, and do not hang a towel or other objects on them. This can damage the gas valve shaft.
- The control knobs may be removed for easy cleaning.
- To clean the knobs, make sure that they are in the Off position and pull them straight off the stems.
- To replace the knobs, make sure the knob has the Off position centered at the top, and slide the knob directly onto the stem.

NOTE

To prevent scratching, do not use abrasive cleaners on any of these materials.

Cleaning the Exterior

Painted and Decorative Trim

For general cleaning, use a cloth with hot soapy water. For more difficult soils and built-up grease, apply a liquid detergent directly onto the soil. Leave it on for 30 to 60 minutes. Rinse with a damp cloth and dry. Do not use abrasive cleaners.

Stainless Steel Surfaces

To avoid scratches, do not use steel wool pads.

1. Place a small amount of stainless steel appliance cleaner or polish on a damp cloth or paper towel.
2. Clean a small area, rubbing with the grain of the stainless steel if applicable.
3. Dry and buff with a clean, dry paper towel or soft cloth.
4. Repeat as necessary.

NOTE

- Do not use a steel wool pad; it will scratch the surface.
- To clean the stainless steel surface, use warm sudsy water or a stainless steel cleaner or polish.
- Always wipe in the direction of the metal surface finish.

- To purchase stainless steel appliance cleaner or polish, or to locate a dealer near you, call our toll-free customer service number: 1-800-243-0000 (USA), 1-888-542-2623(CANADA) or visit our website at: lg

Oven Door

- Use soapy water to thoroughly clean the oven door. Rinse well. Do not immerse the door in water.
- You may use a glass cleaner on the outside glass of the oven door. Do not spray water or glass cleaner on the door vents.
- Do not use oven cleaners, cleaning powders, or harsh abrasive cleaning materials on the outside of the oven door.
- Do not clean the oven door gasket. The oven door gasket is made of a woven material that is essential for a good seal. Care should be taken not to rub, damage, or remove this gasket.

CAUTION

Do not use harsh cleaners or harsh abrasive cleaning materials on the outside of the oven door. Doing so can cause damage.

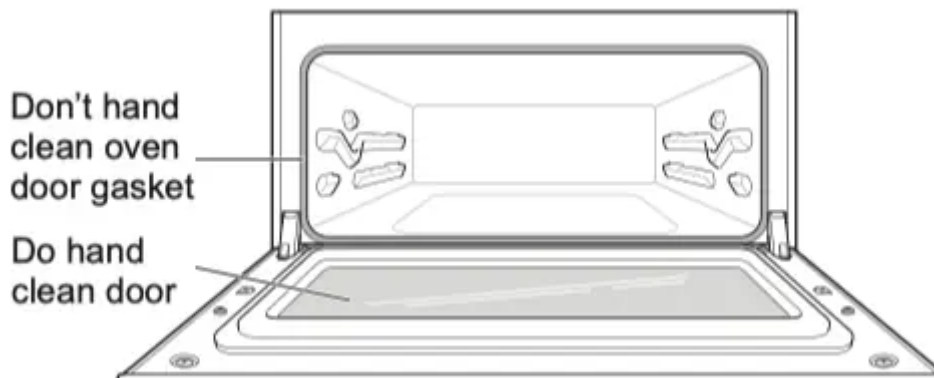

Door Care Instructions

Most oven doors contain glass that can break.

CAUTION

- Do not close the oven door until all the oven racks are fully in place.
- Do not hit the glass with pots, pans, or any other object.
- Scratching, hitting, jarring, or stressing the glass may weaken its structure causing an increased risk of breakage at a later time.

Oven racks

Remove the oven racks before operating the self clean cycle and EasyClean® .

1. Food spilled into the tracks could cause the racks to become stuck. Clean racks with a mild, abrasive cleaner.
2. Rinse with clean water and dry.

NOTE

If the racks are cleaned using the self clean cycle (not recommended), the color will turn slightly blue and the finish will become dull. After the self clean cycle is complete, and the oven has cooled, rub the sides of the racks with wax paper or a cloth containing a small amount of vegetable oil. This will make the racks glide more easily into the rack tracks.

EasyClean®

LG's EasyClean® enamel technology provides two cleaning options for the inside of the range. The EasyClean® feature takes advantage of LG's new enamel to help lift soils without harsh chemicals, and it runs using ONLY WATER for just 10 minutes(Lower) / 15 minutes(Upper) in low temperatures to help loosen LIGHT soils before hand-cleaning.



While EasyClean® is quick and effective for small and LIGHT soils, the Self Clean feature can be used to remove HEAVY, built up soils. The intensity and high heat of the Self Clean cycle may result in smoke which will require the opening up of windows to provide ventilation. Compared to the more intense Self Clean process, your LG oven gives you the option of cleaning with LESS HEAT, LESS TIME, and virtually NO SMOKE OR FUMES.

When needed, the range still provides the self clean option for longer, more thorough oven cleaning for heavier, built up soils.

Benefits of EasyClean®

- Helps loosen light soils before hand-cleaning
- EasyClean® only uses water; no chemical cleaners
- Makes for a better self-clean experience
 - Delays the need for a self-clean cycle
 - Minimizes smoke and odor
 - Can allow for shorter self-clean time

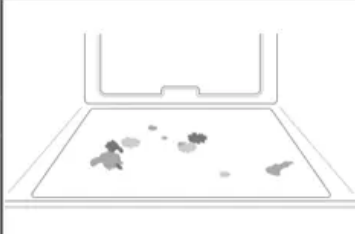
When to Use EasyClean®

Suggested Cleaning Method	Example of Oven Soiling	Soil Pattern	Types of Soils	Common Food Items That Can Soil Your Oven
EasyClean®		Small drops or spots	Cheese or other ingredients	Pizza
		Light splatter	Fat/grease	Steaks, broiled
				Fish, broiled
Meat roasted at low temperatures				
Self Clean*		Medium to heavy splatter	Fat/grease	Meat roasted at high temperatures
		Drops or spots	Filling or sugar based soils	Pies
			Cream or tomato sauce	Casseroles

* The Self Clean cycle can be used for soil that has been built up over time.

Cleaning Tips

- Allow the oven to cool to room temperature before using the EasyClean® cycle. If your oven cavity is above 150 °F (65 °C), Hot will appear in the display, and the EasyClean® cycle will not be activated until the oven cavity cools down.
- A plastic spatula can be used as a scraper to scrape off any chunks or debris before and during oven cleaning.
- Using the rough side of a non-scratch scouring pad may help to take off burnt-on stains better than a soft sponge or towel.
- Certain non-scratch scrubbing sponges, such as those made of melamine foam, available at your local stores, can also help improve cleaning.
- The range should be level to ensure that the bottom surface of the oven cavity is entirely covered by water at the beginning of the EasyClean® cycle.
- For best results, use distilled or filtered water. Tap water may leave mineral deposits on the oven bottom.
- Soil baked on through several cooking cycles will be more difficult to remove with the EasyClean® cycle.
- Do not open the oven door during the EasyClean cycle. Water will not get hot enough if the door is opened during the cycle.
- For hard to reach areas such as the back surface of the lower oven, it is better to use the Self Clean cycle.

EasyClean® Instruction Guide

1. Remove oven racks and accessories from the oven.

2. Scrape off and remove any burnt-on debris with a plastic scraper.



Suggested plastic scrapers:

- Hard plastic spatula
- Plastic pan scraper
- Plastic paint scraper
- Old credit card

3. Fill a spray bottle (10 oz or 300 ml) with water and use the spray bottle to thoroughly spray the inside surfaces of the oven.

4. Use at least 1 / 5 (2 oz or 60 ml) of the water in the bottle to completely saturate the soil on both the walls and in the corners of the oven.



5. Spray or pour the remaining water (8 oz or 240 ml) onto the bottom center of the oven cavity. The indentation on the oven bottom should be fully covered to submerge all soils. Add water if necessary.

NOTE If cleaning multiple ovens, use an entire bottle of water to clean each oven. Do not spray water directly on the door. Doing so will result in water dripping to the floor.

6. Close the oven door. Turn the oven mode knob to select EasyClean® . Press Start.

CAUTION

- Some surfaces may be hot after the EasyClean® cycle. Wear rubber gloves while cleaning to prevent burns.

- During the EasyClean® cycle, the oven becomes hot enough to cause burns. Wait until the cycle is over before wiping the inside surface of the oven. Failure to do so may result in burns.

- Avoid leaning or resting on the oven door glass while cleaning the oven cavity.

7. A tone will sound at the end of the 10 minute (Lower) / 15 minute (Upper) cycle. Touch CLEAR/OFF to clear the display and end the tone.

8. After the cleaning cycle and during handcleaning, enough water should remain on the oven bottom to completely submerge all soils. Add water if necessary. Place a towel on the floor in front of the oven to capture any water that may spill out during hand-cleaning. If you are cleaning the upper oven on a double oven range, it is also best to cover the holes in the top of the lower oven door with a towel to capture any water that may drip into the door during hand cleaning.

9. Clean the oven cavity immediately after the EasyClean® cycle by scrubbing with a wet, non-scratch scouring sponge or pad. (The scouring side will not scratch the finish.) Some water may spill into the bottom vents while cleaning, but it will be captured in a pan under the oven cavity and will not hurt the burner.



NOTE Do not use any steel scouring pads, abrasive pads or cleaners as these materials can permanently damage the oven surface.

10. Once the oven cavity is cleaned, wipe any excess water with a clean dry towel. Replace racks and any other accessories.

11. If some light soils remain, repeat the above steps, making sure to thoroughly soak the soiled areas. If stubborn soils remain after multiple EasyClean® cycles, run the Self Clean cycle. Be sure that the oven cavity is empty of oven racks and other accessories, and that the oven cavity surface is dry before running the Self Clean cycle. Consult the Self Clean section of your owner's manual for further details.

If a self-clean option is not available, scrape off and remove stubborn soil using a scraper.

NOTE

- If you forget to saturate the inside of the oven with water before starting EasyClean®, press CLEAR/OFF to end the cycle. Wait for the range to cool to room temperature and then spray or pour water into the oven and start another EasyClean® cycle.
- The cavity gasket may be wet when the EasyClean® cycle finishes. This is normal. Do not clean the gasket.

- If mineral deposits remain on the oven bottom after cleaning, use a cloth or sponge soaked in vinegar to remove them.
- It is normal for the fan to operate during the EasyClean® cycle.

Self Clean

The Self Clean cycle uses extremely hot temperatures to clean the oven cavity. While running the Self Clean cycle, you may notice smoking or an odor. This is normal; especially if the oven is heavily soiled.

During Self Clean, the kitchen should be well ventilated to minimize the odors from cleaning.

Before Starting Self Clean

- Remove the oven racks, broiler pan, broiler grid, all cookware, aluminum foil or any other material from the oven.
- The kitchen should be well ventilated to minimize the odors from cleaning.
- Wipe any heavy spillovers on the bottom of the oven.
- Make sure that the oven light bulb cover is in place and the oven light is off.
- The oven light cannot be turned on during a Self Clean cycle. The oven light cannot be turned on until the oven temperature has cooled below 500 °F (260 °C) after a Self Clean cycle is complete.

CAUTION

- Do not leave small children unattended near the appliance. During the Self Clean cycle, the outside of the range can become very hot to the touch.
- If you have pet birds, move them to another well-ventilated room. The health of some birds is extremely sensitive to the fumes given off during the Self Clean cycle of any range.
- Do not line the oven walls, racks, bottom or any other part of the range with aluminum foil or any other material. Doing so will destroy heat distribution, produce poor baking results and cause permanent damage to the oven interior (aluminum foil will melt to the interior surface of the oven).
- Do not force the door open. This can damage the automatic door locking system. Use care when opening the oven door after the Self Clean cycle. Stand to the side of the oven when opening the door to allow hot air or steam to escape. The oven may still be VERY HOT.

During the Self Clean cycle, the cooktop elements and warming drawer cannot be used.

NOTE

- Remove oven racks and accessories before starting the Self Clean cycle.
- If oven racks are left in the oven cavity during the Self Clean cycle, they will discolor and become difficult to slide in and out.

- Clean the frame of the oven and door with hot soapy water. Rinse well.
- Do not clean the gasket. The fiberglass material of the oven door gasket cannot withstand abrasion. It is essential for the gasket to remain intact. If you notice it becoming worn or frayed, replace it.
- Wipe up any heavy spillovers on the oven bottom.
- Make sure that the oven light bulb cover is in place and the oven light is off.
- It is normal for the fan to operate during the Self Clean cycle.

Setting Self Clean

The Self Clean function has cycle times of 2, 3, or 4 hours.

Self Clean Soil Guide

Soil Level	Cycle Setting
Lightly Soiled Oven Cavity	2-Hour Self Clean
Moderately Soiled Oven Cavity	3-Hour Self Clean
Heavily Soiled Oven Cavity	4-Hour Self Clean

1. Remove all racks and accessories from the oven.
2. Turn the oven mode knob to select Self Clean. The oven defaults to the recommended threehour self clean for a moderately soiled oven. Press plus(+) or minus(-) repeatedly to cycle through self-clean times in the upper or lower oven. Both ovens cannot use the self-clean function at the same time.
3. Press Start.
4. Once the self-clean cycle is set, the oven door locks automatically and the lock icon displays. You will not be able to open the oven door until the oven has cooled. The lock releases automatically when the oven has cooled.

CAUTION

Do not force the oven door open when the lock icon is displayed. The oven door remains locked until the oven temperature has cooled. Forcing the door open will damage the door.

Setting Self Clean with a Delayed Start

1. Remove all racks and accessories from the oven.

2. Turn the oven mode knob to select Self Clean. The oven defaults to the recommended threehour self clean for a moderately soiled oven. Press plus(+) or minus(-) repeatedly to cycle through self-clean times in the upper or lower oven. Both ovens cannot use the self-clean function at the same time.
3. Press Start.
4. Press plus(+) or minus(-) to enter the time of day you would like the Self Clean to start.
5. Press Start.

NOTE It may become necessary to cancel or interrupt a Self Clean cycle due to excessive smoke or fire in the oven. To cancel the Self Clean function, touch CLEAR/OFF.

During Self Clean

- The Self Clean cycle uses extremely hot temperatures to clean the oven cavity. While running the Self Clean cycle, you may notice smoking or an odor. This is normal, especially if the oven is heavily soiled.
- As the oven heats, you may hear sounds of metal parts expanding and contracting. This is normal and will not damage the oven.
- Do not force the oven door open when the lock is displayed. The oven door remains locked until the oven temperature has cooled. Forcing the door open will damage the door.

After the Self Clean Cycle

- The oven door remains locked until the oven temperature has cooled.
- You may notice some white ash in the oven. Wipe it off with a damp cloth or a soap-filled steel wool pad after the oven cools. If the oven is not clean after one self-clean cycle, repeat the cycle.
- If oven racks were left in the oven and do not slide smoothly after a self-clean cycle, wipe racks and rack supports with a small amount of vegetable oil to make them glide more easily.
- Fine lines may appear in the porcelain because it went through heating and cooling. This is normal and will not affect performance.

NOTE

- The Self Clean cycle cannot be started if the Lockout feature is active.
- Once the Self Clean cycle is set, the oven door locks automatically. You will not be able to open the oven door until the oven is cooled. The lock releases automatically.
- Once the door has been locked, the lock indicator light stops flashing and remains on. Allow about 15 seconds for the oven door lock to activate.
- If the clock is set for a 12-hour display (default) the Delayed Self Clean can never be set to start more than 12 hours in advance.

- After the oven is turned off, the convection fan keeps operating until the oven has cooled down.

Changing the Oven Light

The oven light is a standard 40-watt appliance bulb. It turns on when the oven door is open. When the oven door is closed, touch Start to turn it on or off.

WARNING

- Make sure that the oven and bulb are cool.
 - Disconnect the electrical power to the range at the main fuse or circuit breaker panel. Failure to do so can result in severe personal injury, death, or electrical shock.
1. Unplug the range or disconnect power.
 2. Turn the glass bulb cover in the back of the oven counterclockwise to remove.
 3. Turn the bulb counterclockwise to remove it from the socket.
 4. Insert the new bulb and turn it clockwise.
 5. Insert the glass bulb cover and turn it clockwise.
 6. Plug in the range or reconnect the power.

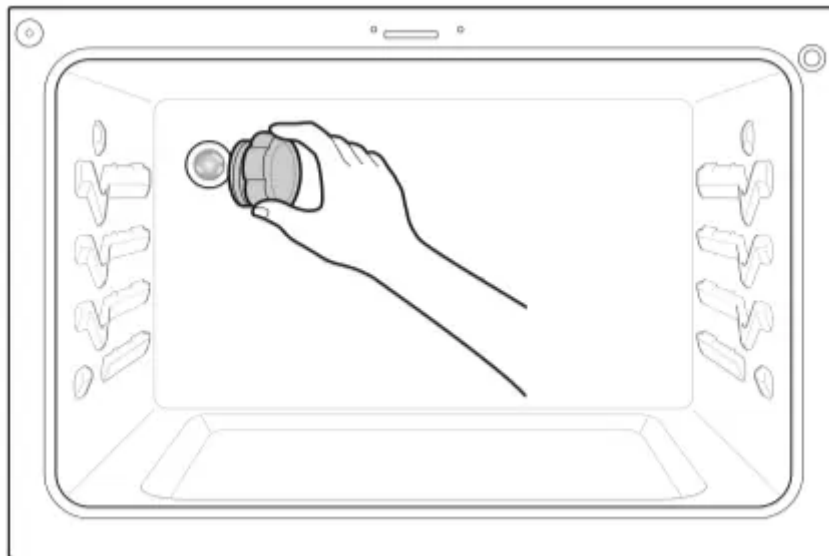

Removing and replacing the Lift-Off Oven Doors

CAUTION

- Be careful when removing and lifting the door.
- Do not lift the door by the handle. The door is very heavy.

Upper Oven

Removing the Door

1. Fully open the door.
2. Lift up and rotate the hinge locks hinge until they stop.

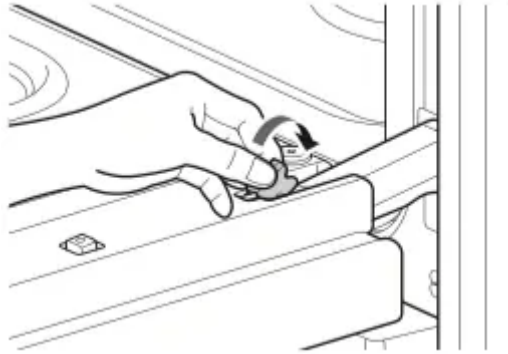

3. Close the door to 30 degrees (you will feel the door stop). The hinge locks will contact the oven frame.



4. On both sides of the door, press down release button on each hinge.

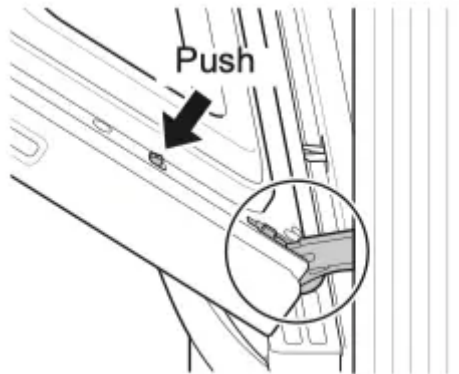

5. Lift the door up until it is clear of the hinges.

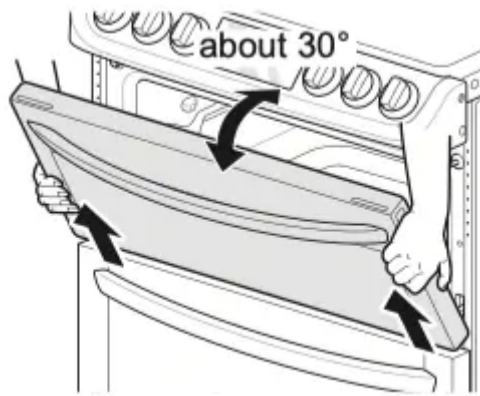

Replacing the Door

1. Be sure both hinges are in a 30 degree position.
2. Slide the door back onto the hinges until you hear a solid click and the release buttons have engaged.

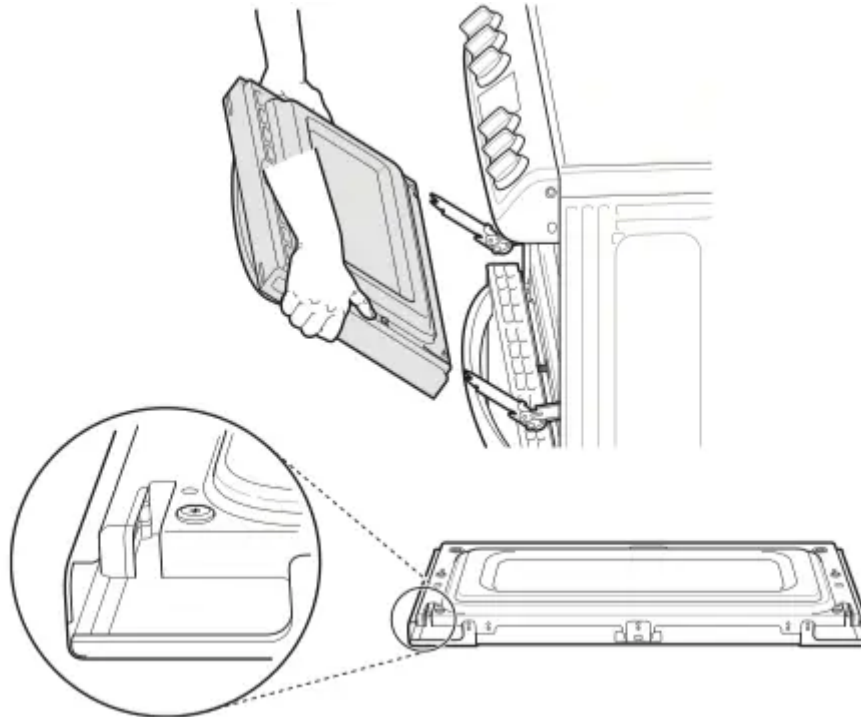

3. Fully open the door.
4. Push the hinge locks down onto the door frame.

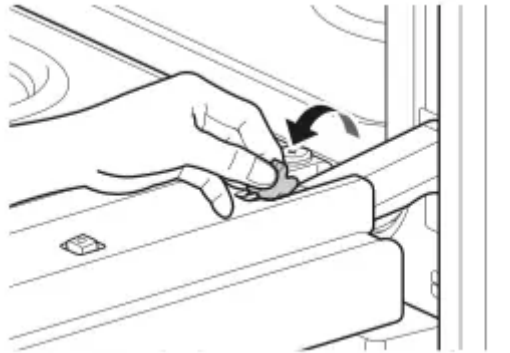

5. Close the oven door.

Lower Oven

Removing the Door

1. Fully open the door.
2. Unlock the hinge locks, rotating them as far toward the open door frame as they will go.

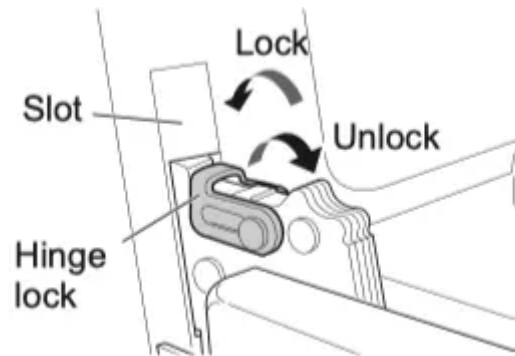

3. Firmly grasp both sides of the door at the top.
4. Close the door to the removal position (approximately five degrees) which is halfway between the broil stop position and fully closed. If the position is correct, the hinge arms will move freely.

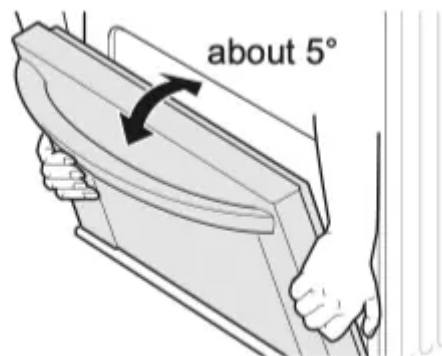

5. Lift door up and out until the hinge arms are clear of the slots.

Replacing the Door

1. Firmly grasp both sides of the door at the top.
2. With the door at the same angle as the removal position, seat the indentation of the hinge arms into the bottom edge of the hinge slots. The notch in the hinge arms must be fully seated into the bottom edge of the slots.

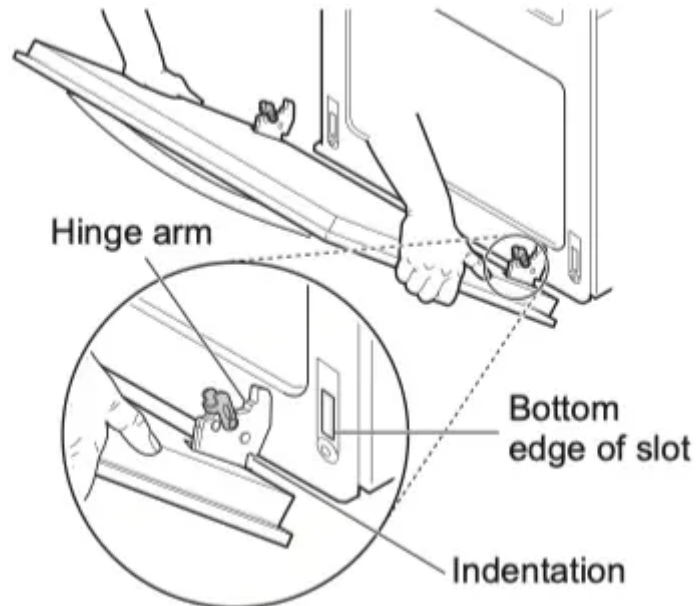

3. Open the door fully. If the door will not open fully, the indentation is not seated correctly in the bottom edge of the slots.
4. Lock the hinge locks, rotating them back toward the slots in the oven frame until they lock.

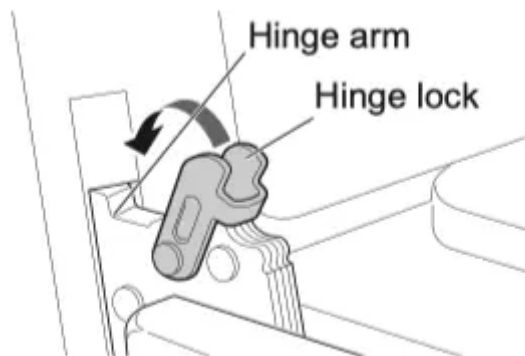

5. Close the oven door.

TROUBLESHOOTING

FAQs

What types of cookware are recommended for use with the cooktop?

- The pans must have a flat bottom and straight sides.
- Only use heavy-gauge pans.

- The pan size must match the amount of food to be prepared and the size of the surface element.
- Use tight fitting lids.
- Only use flat-bottom woks.

Why do the heating elements appear to be turning On and OFF during use of the cooktop or oven?

Depending on your cooktop element setting or the temperature selected in your oven it is NORMAL for the cooking elements to cycle on and off.

My new oven doesn't cook like my old one. Is there something wrong with the temperature settings?

No, your oven has been factory tested and calibrated. For the first few uses, follow your recipe times and temperatures carefully. If you still think your new oven is too hot or too cold, you can adjust the oven temperature yourself to meet your specific cooking needs. Refer to the Oven Temperature Adjustment section in this manual for easy instructions on how to adjust your thermostat.

Is it normal to hear a clicking noise coming from the back of my oven when I am using it?

Your new range is designed to maintain a tighter control over your oven's temperature. You may hear your oven's heating elements click on and off more frequently on your new oven. This is NORMAL.

Why is the time flashing?

This means that the product has just been plugged in, or that it has experienced a power interruption. To clear the flashing time, touch any button and reset the clock if needed.

During convection cooking the fan stops when I open the door. Is that normal?

Yes, this is normal. When the door is opened, the convection fan will stop until the door is closed.

Can I use aluminum foil to catch drippings in my oven cavity?

Never use aluminum foil to line the bottom or sides of the oven or the warming drawer. The foil will melt and stick to the bottom surface of the oven, and will not be removable. Use a sheet pan placed on a lower oven rack to catch drippings instead. (If foil has already melted onto the bottom of the oven, it will not interfere with the oven's performance.)

Can I use aluminum foil on the racks?

Do not cover racks with aluminum foil. Covering entire racks with foil restricts air flow, leading to poor cooking results. Use a sheet pan lined with foil under fruit pies or other acidic or sugary foods to prevent spillovers from damaging the oven finish.

CAUTION

Foil may be used to wrap food in the oven or warming drawer, but do not allow the foil to come into contact with the exposed heating/broiling elements in the oven. The foil could melt or ignite, causing smoke, fire, or injury.

Can I leave my racks in the oven when running a Self Clean cycle?

No. Although it will not damage the racks, it will discolor them and may make them hard to slide in and out during use. Remove all items from the oven before starting a Self Clean cycle.

What should I do if my racks are sticky and have become hard to slide in and out?

Over time, the racks may become hard to slide in and out. Apply a small amount of olive oil to the ends of the racks. This will work as a lubricant for easier gliding.

What should I do for hard to remove stains on my cooktop?

The cooktop should be cleaned after every use to prevent permanent staining. When cooking foods with high sugar content, such as tomato sauce, clean the stain off with a scraper while the cooktop is still warm. Use an oven mitt when scraping to prevent burns. Refer to the MAINTENANCE section of this owner's manual for further instruction.

Why aren't the function buttons working?

Make sure that the range is not in Lockout mode. The lock will show in the display if Lockout is activated. To deactivate Lockout, touch and hold Lower CLEAR/OFF for three seconds. The unlock melody sounds and Loc appears in the display until the controls are unlocked.

My range is still dirty after running the EasyClean® cycle. What else should I do?

The EasyClean® cycle only helps to loosen light soils in your oven range to assist in hand-cleaning of your oven. It does not automatically remove all soils after the cycle. Some scrubbing of your oven range is required after running the EasyClean® cycle.

I tried scrubbing my oven after running EasyClean®, but some soils still remain. What can I do?

The EasyClean® feature works best when the soils are fully soaked and submerged in water before running the cycle and during hand-cleaning. If soils are not sufficiently soaked in water, it can negatively affect the cleaning performance. Repeat the EasyClean® process using sufficient water. Sugar-based and certain greasy soils are especially hard to clean. If some stubborn soils remain, use the Self Clean feature to thoroughly clean your oven.

Soils on my oven walls are not coming off. How can I get my walls clean?

Soils on the side and rear walls of your oven range may be more difficult to fully soak with water. Try repeating the EasyClean® process with more than the ¼ cup (2 oz or 60 ml) of spray recommended.

Will EasyClean completely?

It depends on the soil type. Sugar-based and certain grease stains are especially hard to clean. Also, if stains are not sufficiently soaked in water, this can negatively affect cleaning performance. If stubborn or built-up stains remain, use the Self Clean feature. Refer to the Self Clean section of your owner's manual.

Are there any tricks to getting some of the stubborn soils out?

Scraping the soils with a plastic scraper before and during hand-cleaning is recommended. Fully saturating soils with water is also recommended. However, certain types of soils are harder to clean than others. For these stubborn soils, the Self Clean cycle is recommended. Consult the Self Clean section of your owner's manual for details.

Is it safe for my convection fan, broil burner or heater element to get wet during EasyClean® ?

Yes. The convection fan, broiler burner or heater element may get a little wet during cleaning. However, direct spray onto the broil burner and heater elements is not necessary because these are self-cleaning during regular use.

Do I need to use all 1 1 / 4 cups (10 oz or 300 ml) of water for EasyClean® ?

Yes. It is highly recommended that 1 cup (8 oz or 240 ml) of water be sprayed or poured on the bottom and an additional 1 / 4 cup (2 oz or 60 ml) of water be sprayed on walls and other soiled areas to fully saturate the soils for better cleaning performance.

I see smoke coming out of my oven range's cooktop vents during EasyClean® . Is this normal?

This is normal. This is not smoke. It is actually water vapor (steam) from the water in the oven cavity. As the oven heats briefly during EasyClean® , the water in the cavity evaporates and escapes through the oven vents.

How often should I use EasyClean® ?

EasyClean® can be performed as often as you wish. EasyClean® works best when your oven is LIGHTLY soiled from such things as LIGHT grease splatter and small drops of cheese. Please refer to the EasyClean® section in your owner's manual for more information.

What is required for EasyClean® ?

A spray bottle filled with 1¼ cups (10 oz or 300 ml) of water, a plastic scraper, a non-scratch scrubbing pad and a towel. You should not use abrasive scrubbers such as heavy-duty scouring pads or steel wool. Except for a towel, all of the materials you need are included in a special cleaning kit with your new range.

Can I run the EasyClean cycle on both of my ovens at once?

Yes. You can run the EasyClean® cycle on both ovens at the same time. Some oven surfaces will be hot after the cycle completes running. Avoid leaning or resting on the oven door glass while cleaning the oven cavities. You cannot run the Self Clean cycle on both ovens at the same time.

Is it safe for water to spill into the oven bottom vents during cleaning?

Some water spillage into the oven bottom vents (gas range) is okay. However, it is recommended to try avoid spilling too much water into the vents.

Before Calling for Service

Before you call for service, review this list. It may save you time and expense. The list includes common occurrences that are not the result of defective workmanship or materials in this appliance.



Symptoms	Possible Cause / Solution
<p>Top burners do not light or do not burn evenly.</p>	<ul style="list-style-type: none"> • Make sure that the electrical plug is inserted into a live, properly grounded outlet. • Remove the burners and clean them. Check the electrode area for burnt on food or grease. See Cleaning Burner Heads/Caps in the MAINTENANCE section. • Make sure that the burner parts are installed correctly. See Removing and Replacing the Gas Surface Burners in the MAINTENANCE section.
<p>Burner flames are very large or yellow.</p>	<p>If the range is connected to LP gas, contact the technician who installed your range or made the conversion.</p>
<p>Surface burners light but the oven does not.</p>	<p>Make sure that the oven gas shut-off valve, located behind the range, is fully open.</p>
<p>Food does not bake or roast properly.</p>	<ul style="list-style-type: none"> • Incorrect oven control settings. See Control Panel Overview in the OPERATION section. • Incorrect rack position. See Removing and Replacing the Oven Racks in the OPERATION section. • Incorrect cookware is being used. See Convection Bake in the OPERATION section. • Oven thermostat needs adjustment. • See Adjusting the Oven Thermostat in the OPERATION section. • The Clock is not set correctly. See Changing Oven Settings in the OPERATION section. • Aluminum foil used improperly in the oven. See Removing and Replacing the Oven Racks.
<p>Food does not broil properly in the oven.</p>	<ul style="list-style-type: none"> • Incorrect oven control settings. See Control Panel Overview in the OPERATION section. • The oven door is not closed. See Broil in the OPERATION section. • Aluminum foil used on the broiling pan and grid is not fitted properly.



<p>Oven temperature is too hot or too cold.</p>	<p>The oven thermostat needs adjustment. See Adjusting the Oven Thermostat in the OPERATION section.</p>
<p>Clock and timer does not work.</p>	<ul style="list-style-type: none"> • Make sure the electrical plug is inserted into a live, properly grounded outlet. Replace the fuse or reset the circuit breaker. • Improper oven control settings. See Changing Oven Settings in the OPERATION section.
<p>Oven light does not work.</p>	<ul style="list-style-type: none"> • The light bulb is loose or defective. Tighten or replace the bulb. • The plug on the range is not completely inserted in the electrical outlet. Make sure the electrical plug is inserted into a live, properly grounded outlet.
<p>Self Clean is not working.</p>	<ul style="list-style-type: none"> • The oven temperature is too high to set a self clean operation. Allow the range to cool down to room temperature and reset the controls. • Improper oven control settings. See Self Clean in the MAINTENANCE section.
<p>“Crackling” or “popping” sound.</p>	<ul style="list-style-type: none"> • This is the sound of the metal heating up and cooling down during both the cooking and cleaning functions. This is normal.
<p>Too much smoke during the Self Clean cycle.</p>	<p>Too much soil in the oven. Open the windows to get rid of the smoke from the room. Touch the Upper Clear/Off or Lower Clear/Off key. Wait until the light goes off before trying to open the oven door. Wipe up the excess soil and reset the clean cycle.</p>
<p>The oven door does not open after a Self Clean cycle.</p>	<p>The oven temperature is too high. Wait up to one hour for it to cool down.</p>



Symptoms	Possible Cause / Solution								
<p>The oven is not clean after a Self Clean cycle.</p>	<ul style="list-style-type: none"> • Incorrect oven control settings. See Self Clean in the MAINTENANCE section. • The oven was heavily soiled. Clean up heavy spills before beginning the Self Clean cycle. Heavily soiled ovens may need either a longer Self Clean or two Self Clean cycles. 								
<p>Clean and door flash in the display.</p>	<ul style="list-style-type: none"> • The self clean cycle has been selected, but the door is not closed. - Close the oven door. 								
<p>"Loc" message appears when you want to cook.</p>	<ul style="list-style-type: none"> • Oven is too hot. - Allow the oven to cool below locking temperature. • Allow about one hour for the oven to cool after the completion of a Self Clean cycle. The door can be opened when the lock is no longer displayed. • The control and door may be locked. 								
<p>Oven control beeps and displays an F error code.</p>	<ul style="list-style-type: none"> • Check the main gas shut-off valve or the oven gas shut-off valve and call for service. • Remove the power from the range for five minutes and then reconnect the power. If the function error code repeats, call for service. <table border="1" data-bbox="643 1451 1378 1785"> <thead> <tr> <th data-bbox="643 1451 820 1518">CODE</th> <th data-bbox="820 1451 1378 1518">CAUSE</th> </tr> </thead> <tbody> <tr> <td data-bbox="643 1518 820 1574">F-3</td> <td data-bbox="820 1518 1378 1574">Touch key error</td> </tr> <tr> <td data-bbox="643 1574 820 1682">F-9</td> <td data-bbox="820 1574 1378 1682">Main oven heating error (Upper oven)</td> </tr> <tr> <td data-bbox="643 1682 820 1785">F-19</td> <td data-bbox="820 1682 1378 1785">Main oven heating error (Lower oven)</td> </tr> </tbody> </table>	CODE	CAUSE	F-3	Touch key error	F-9	Main oven heating error (Upper oven)	F-19	Main oven heating error (Lower oven)
CODE	CAUSE								
F-3	Touch key error								
F-9	Main oven heating error (Upper oven)								
F-19	Main oven heating error (Lower oven)								
<p>The oven racks were cleaned in a Self Clean cycle.</p>	<p>Apply a small amount of vegetable oil to a paper towel and wipe the edges of the oven racks. Do not use lubricant sprays.</p>								



Clock is flashing.	Power outage or surge. Reset the clock. If the oven was in use, you must reset it by touching the Upper Clear/Off or Lower Clear/Off key. Reset the clock and any cooking function.
“Burning” or “oily” odor emitting from the vent.	This is normal in a new oven. To speed the process, set a Self Clean cycle for a minimum of three hours. See Self Clean in the MAINTENANCE section.
Strong odor.	An odor from the insulation around the inside of the oven is normal for the first few times the oven is used.
Fan noise	<ul style="list-style-type: none"> • A convection fan may automatically turn on and off. - This is normal.
Fan operation	It is normal for the fan to operate periodically throughout a normal bake cycle in the lower oven. This is to ensure even baking results.
Burners are not lighting properly after cleaning the cooktop surface.	Make sure that the burner heads and caps are completely dry and properly positioned.
When lighting just one burner, clicking noise is heard from all the burners.	This is normal. Electric spark igniters from the burners cause the clicking noise. All the spark igniters on the cooktop will activate when igniting just one burner.
Wi-Fi network does not connect properly.	<ul style="list-style-type: none"> • If the appliance is having trouble connecting to the Wi-Fi network, it may be too far from the router. Purchase a Wi-Fi repeater (range extender) to improve the Wi-Fi signal strength. • The Wi-Fi connection may not connect or may be interrupted because of the home network environment. • The network connection may not work properly depending on the internet service provider. • The surrounding wireless environment can make the wireless network service run slowly.

Light can be seen through the oven air vents.

While the Broil function is running, it is normal to see a light between the oven air vents.

Warning

This content is compiled from multiple sources and is provided for reference purposes only. It may not be complete or fully applicable to all situations. If you are unable to resolve your issue, please contact the product manufacturer or an authorized service provider for official support.

