

Introducing your new range

OVERVIEW

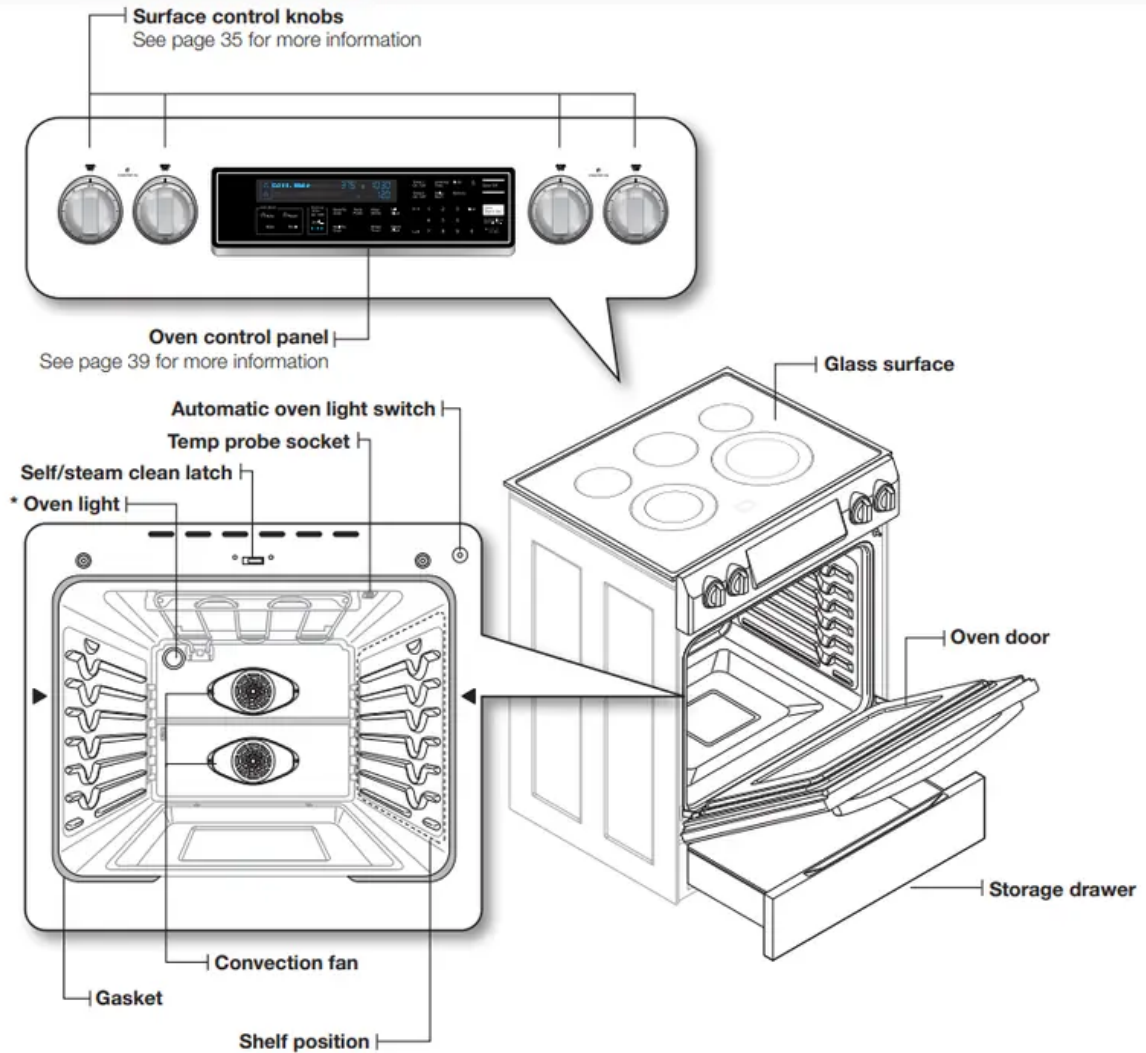

WHAT'S INCLUDED WITH YOUR RANGE



* Wire racks (2)



* Recessed rack (1)



* Temp probe (1)

If you need an accessory marked with a *, you can buy it from the Samsung Contact Center (1-800-726-7864).



Before you begin

Clean the oven thoroughly before using it for the first time. Remove the accessories, set the oven to bake, and then run the oven at 400 °F for 1 hour before using. There will be a distinctive odor. This is normal. Ensure your kitchen is well ventilated during this conditioning period.

Getting started

SETTING THE CLOCK

The clock must be set to the correct time of day for the automatic oven timing functions to work properly.

- The time of day cannot be changed during a timed cooking, a delay-timed cooking, or a selfcleaning cycle.
- You can choose between a 12-hour or 24-hour display. The default is 12-hour.

How to set the clock

1. Start the set up. Press Clock.
2. Press Clock to select AM or PM. (Skip this step on 24 hour display setting)
3. Enter the current time in hours and minutes on the number pad. eg. 1,3,0 for 1:30
4. Press Clock or Oven Start/Set to save the changes

CONTROL PANEL DISPLAY MODES

Sleep Mode

Your control panel will remain in a sleep mode when not in use. Only the clock will display. You will need to wake the control panel to begin any function.



Wake Mode

To wake the control panel, touch the wake-up key. After 2 minutes without activity (or one minute when the oven is operating in standby mode), the control panel will return to Sleep mode. User preferences are available in this mode as well as timers, the oven light, and the control lock.

TURNING THE OVEN LIGHT ON AND OFF

- The oven light turns on automatically when the door is opened.
- The oven light turns off automatically when the door is closed.
- You can turn the oven light on and off manually by pressing Oven Light.

CONTROL LOCKOUT

Control lockout lets you lock the buttons on the touch pad so they cannot be activated accidentally. Control lockout is only activated in standby mode.

How to activate the control lockout feature

1. Press Control Lock Hold 3 Sec. for 3 seconds.

The display will show "Loc" and Lock icon continuously, as well as the current time. All functions must be cancelled before Control lockout is activated. This function is available only when the oven temperature is under 400 °F.

How to unlock the controls

1. Press Control Lock Hold 3 Sec. for 3 seconds. "Loc" and the Lock icon will disappear from the display.

SETTING THE KITCHEN TIMER

The timer counts down elapsed time and will beep when the time you set has elapsed. It does not start or stop cooking functions. You can use the kitchen timer with any of the other oven functions.

How to set the timer

1. Turn the timer on.

Press Timer1 On/Off (Timer2 On/Off).

2. Enter the amount of time you want.

Enter the amount of time you want using the number pad, eg. 1, 5. The timer can be set for any amount of time from 1 minute to 9 hours and 99 minutes. If you make a mistake, press Clear and enter the amount of time again.

3. Start the timer.

Press Timer1 On/Off (Timer2 On/Off) or Oven Start/Set.

4. When the set time has elapsed, the oven will beep and the display will show End until you press the pad. You can cancel the timer at any time by pressing Timer1 On/Off (Timer2 On/Off).

Surface cooking

ABOUT SURFACE COOKING

CAUTION

BEFORE COOKING

- Do not use the glass cooktop surface as a cutting board.
- Do not place or store items that can melt or catch fire on the glass cooktop, even when it is not being used.
- Turn the surface units on only after placing the cookware on them.
- Do not store heavy items above the cooktop surface. They could fall and damage it.

CAUTION

DURING COOKING

- Do not place aluminum foil or plastic items such as salt and pepper shakers, spoon holders, or plastic wrappings on the range when it is in use. The hot air from the vent could melt plastics or ignite flammable items.
- Make sure the correct surface unit is turned on.
- Never cook food directly on the glass. Always use cookware.
- Always place the pan in the center of the surface unit you are cooking on.
- Never leave surface units unattended while using a high heat setting. Boilovers cause smoking and greasy spillovers that may catch on fire.
- Turn the surface units off before removing cookware.
- Do not use plastic wrap to cover food. Plastic may melt onto the surface and be very difficult to remove.
- Cooling fan can be operated during cooktop cooking.

CAUTION

AFTER COOKING

- Do not touch the surface units until they have cooled down.
- The surface may be still be hot and burns may occur if the glass surface is touched before it has cooled down sufficiently.
- Immediately clean spills on the cooking area to prevent a tough cleaning chore later.
- If you have a cabinet directly above the cooking surface, make sure that the items in it are infrequently used and can be safely stored in an area subjected to heat. Temperatures in the cabinet may be unsafe for items such as volatile liquids, cleaners, and aerosol sprays.

About the radiant surface elements

The temperature of radiant surface elements rises gradually and evenly. As the temperature rises, the radiant element will glow red. To maintain the selected setting, the element will cycle on and off. The heating element retains enough heat to provide a uniform and consistent heat during the off cycle. For efficient cooking, turn off the element several minutes before cooking is complete. This will allow residual heat to complete the cooking process.

Radiant elements have a limiter that allows the element to cycle ON and OFF, even at the HI setting. This helps to prevent damage to the ceramic cooktop. Cycling at the HI setting is normal. It can also occur if the cookware is too small for the radiant element or if the cookware bottom is not flat.

Location of the radiant surface elements and controls

The radiant control knobs operate the radiant surface elements on the cooktop as shown below.

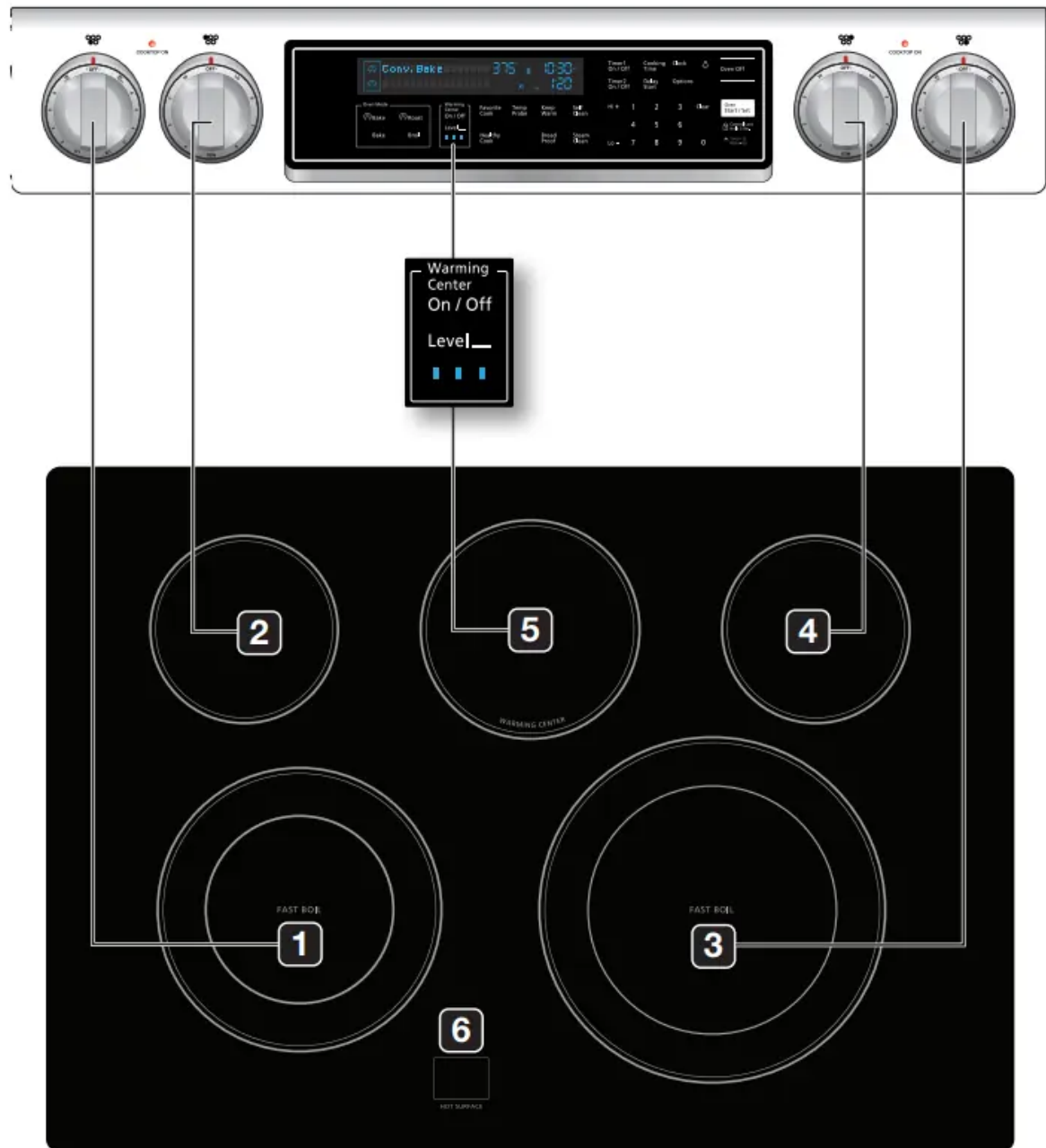

1. Left Front: 6"/9", 3000 W
2. Left Rear: 6", 1200 W
3. Right Front: 9"/12", 3000 W
4. Right Rear: 6", 1200 W
5. Warming Center: 100 W
6. Hot surface indicator

Hot surface indicator

- Comes on when the unit is turned on or hot to the touch.
- Stays on even after the unit is turned off.
- Glows until the unit is cooled to approximately 150 °F.

Cooking areas

- The cooking areas on your range are identified by permanent circles on the glass cooking surface. For the most efficient cooking, fit the pan size to the element size.
- Pans should not extend more than ½" to 1" beyond the cooking area.
- When a control is turned on, you can see a glow through the glass cooking surface. The element will cycle on and off to maintain the preset heat setting, even at high settings.
- For more information on selecting proper types of cookware, refer to the section "Using the proper cookware" on page 37.

When you operate the knob, beep sounds once. However, if you operate multiple knobs, beep will sound once for the initially operated knob.

HOW TO SET THE APPLIANCE FOR SURFACE COOKING

CAUTION:

- The surface elements may be hot even when off and burns can occur. Do not touch the surface elements until they have cooled down sufficiently.
- At high or medium-high settings, never leave food unattended. Boilovers cause smoking and greasy spillovers may catch on fire.
- Be sure you turn the control knob to OFF when you finish cooking.

Single surface unit control knob (left rear, right rear)

1. Push the knob in.
2. Turn in either direction to the setting you want.
 - At both the off and high settings, the knob clicks into position.

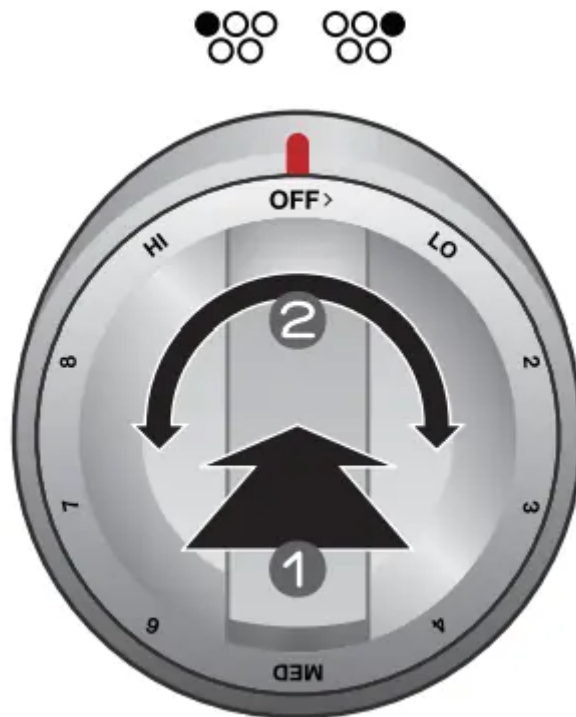

Dual surface unit control knob (left front, right front)

1. Push the knob in.
2. Turn in either direction to the setting you want.
 - To use the single surface unit, turn the control knob to the middle burner setting.
 - To use the dual surface unit, turn the control knob to the large burner setting.

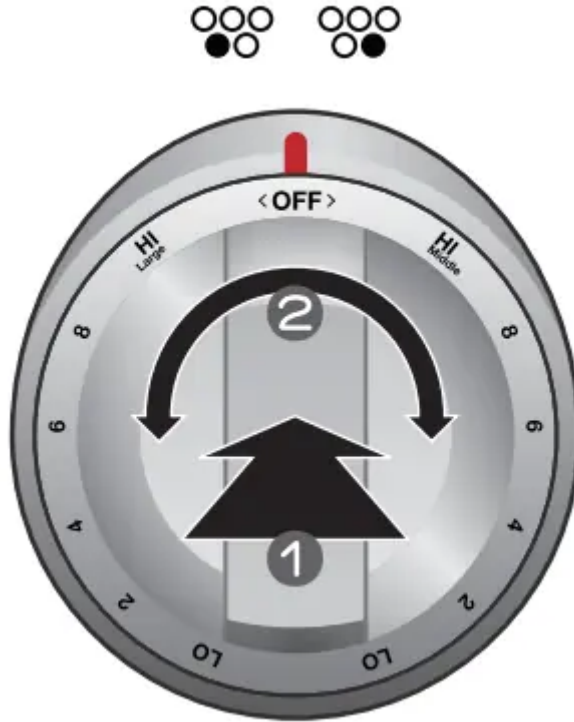

If you removed knob for cleaning, insert it after check to direction. (refer to above figure)

CAUTION The area on the knob between the high and off settings is not appropriate for cooking.

Recommended settings

SETTING	TYPE OF COOKING
HIGH	Starting most foods, bringing water to a boil, pan broiling
MEDIUM HIGH	Continuing a rapid boil, frying, deep fat frying
MEDIUM	Maintaining a slow boil, thickening sauces and gravies, steaming vegetables
MEDIUM LOW	Keeping foods cooking, poaching, stewing
LOW	Keeping foods warm, melting, simmering

Using the warming center

The warming center, located in the back center of the glass surface, will keep hot, cooked food at serving temperature.

- The surface warmer will not glow red like the cooking elements.

CAUTION

- Do not warm food on the warming center for more than two hours.



- Use only cookware and dishes recommended as safe for oven and cooktop use.
 - Always use potholders or oven mitts when removing food from the warming center as cookware and plates will be hot.
 - When warming pastries and breads, use covers that have an opening to allow moisture to escape.
 - Do not use plastic wrap to cover foods. Plastic may melt onto the surface and be very difficult to clean off.
 - Food should be kept in its container and covered with a lid or aluminum foil to maintain food quality.
 - Always start with hot food. Eating uncooked or cold food placed on the warming center could result in illness.
1. Turn the warming center on.
Press Warming Center On/Off.
 2. Select the power setting you want.
Press Warming Center Level once to set it to the Level 1 setting. Press the pad twice for the Level 2 setting, 3 times for Level 3.
 3. Turn the warming center off.
Press Warming Center On/Off.
- Pressing Oven Off does not turn the warming center off.
 - For best results, all foods on the warming center should be covered with a lid or aluminum foil. When warming pastries or breads, the lid or foil should be vented to allow moisture to escape.

Recommended settings





LEVEL	TYPE OF FOOD
1	Breads/pastries, casseroles, gravies, eggs
2	Dinner plate with foods, soups (cream), vegetables, sauces, stews, meats
3	Fried foods, soups (liquid), hot beverages

USING THE PROPER COOKWARE

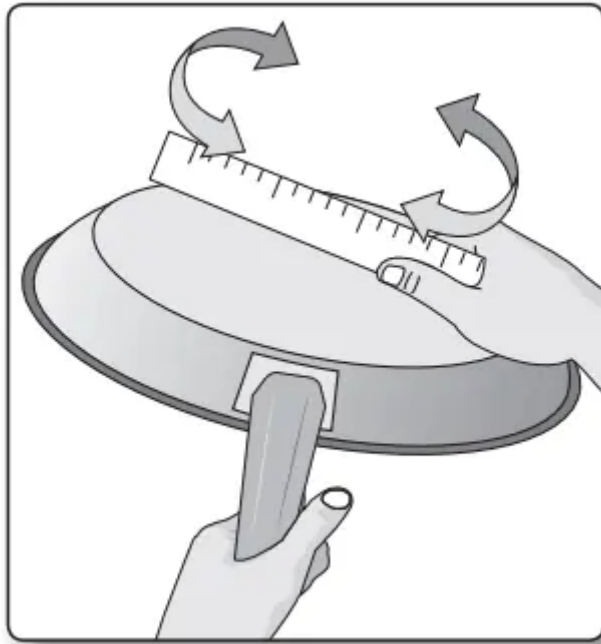
Using the right cookware can prevent many problems, such as uneven cooking or extended cooking times. Using the proper pans will reduce cooking times and cook food more evenly.

Check for flatness by rotating a ruler across the bottom of the cookware.



CORRECT	INCORRECT
 <p>Flat bottom and straight sides.</p> <ul style="list-style-type: none"> • Tight fitting lids. • Weight of handle does not tilt pan. • Pan is well balanced. • Pan size matches the amount of food to be prepared and the size of the surface element. • Made of a material that conducts heat well. • Always match pot diameter to element surface diameter. 	 <p>Curved and warped pan bottoms.</p>  <p>Pan overhangs element by more than one-half inch.</p>  <p>Pan is smaller than element.</p>  <p>Heavy handle tilts pan.</p>

CHOOSING THE PROPER COOKWARE

What your cookware is made of determines how evenly and quickly heat is transferred from the surface element to the pan bottom.

- **ALUMINUM** - Excellent heat conductor. Some types of food will cause the aluminum to darken. (Anodized aluminum cookware resists staining and pitting.) If aluminum pans are slid across the ceramic cooktop, they may leave metal marks that resemble scratches. Remove these marks as soon as the cooktop cools down.
- **COPPER** - Excellent heat conductor but discolors easily. May leave metal marks on ceramic glass (see above).
- **STAINLESS STEEL** - Slow heat conductor with uneven cooking results. Is durable, easy to clean and resists staining.

- **CAST IRON** - A poor conductor, but retains heat very well. Cooks evenly once cooking temperature is reached. Not recommended for use on ceramic cooktops.
- **ENAMELWARE** - Heating characteristics will vary depending on base material. Porcelain enamel coating must be smooth to avoid scratching ceramic cooktops.
- **GLASS** - Slow heat conductor. Not recommended for ceramic cooktop surfaces because it may scratch the glass.

PROTECTING THE COOKTOP SURFACE

Cleaning

- Clean the cooktop before using it for the first time.
- Clean your cooktop daily or after each use. This will keep your cooktop looking good and can prevent damage.
- If a spillover occurs while you are cooking, immediately clean the spill from the cooking area while it is hot to prevent a tough cleaning chore later. Using extreme care, wipe the spill with a clean dry towel.
- Do not allow spills to remain on the cooking area or the cooktop trim for a long period of time.
- Do not use abrasive cleansing powders or scouring pads, which will scratch the cooktop.
- Do not use chlorine bleach, ammonia, or other cleansers not specifically recommended for use on a glass-ceramic surface.

Preventing marks and scratches

- Do not use glass cookware. It may scratch the cooktop.
- Do not place a trivet or wok ring between the cooktop and the pan. These items can mark or scratch the cooktop.
- Make sure the cooktop and the pan bottom are clean.
- Do not slide metal pans across the cooktop.

Preventing stains

- Do not use a soiled dish cloth or sponge to clean the cooktop surface. A film will remain, which may cause stains on the cooking surface after the area is heated.
- Continuously cooking on a soiled surface can result in a permanent stain.

Preventing other damage

- Do not allow plastic, sugar, or foods with high sugar content to melt onto the hot cooktop. Should this happen, clean immediately.
- Do not let a pan boil dry. This will damage the cooktop and the pan.
- Do not use the cooktop as a work surface or cutting board.

- Do not cook food directly on the cooktop. Always use the proper cookware.

Operating the oven

THE OVEN CONTROL PANEL

READ THE INSTRUCTIONS CAREFULLY BEFORE USING THE OVEN. For the best results, familiarize yourself with the various features and functions of the oven as described below. Detailed instructions for each feature and function follow later in this user manual.

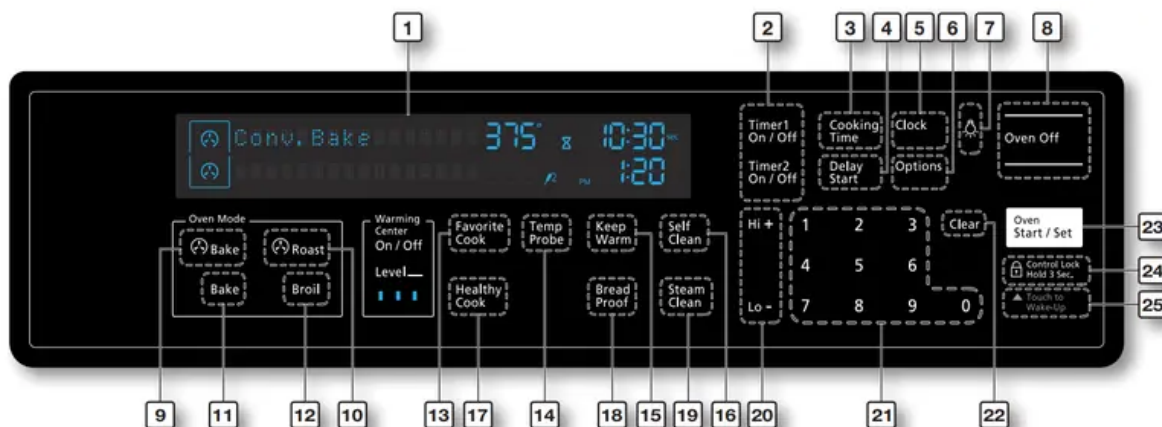

1. DISPLAY: Shows the time of day, oven temperature, whether the oven is in the bake, broil or self-cleaning mode, and the time set for the timer or automatic oven operations.
2. TIMER ON/OFF: Use to set or cancel the minute timer. The minute timer does not start or stop cooking.
3. COOKING TIME: Press and then use the number pad to set the amount of time you want your food to cook. The oven will shut off when the cooking time has run out.
4. DELAY START: Press to set the oven to start and stop automatically at a time you set. (Bake, Conv.bake/Roast, Cooking Time, and self clean only.)
5. CLOCK: Use to set the time of day.
6. OPTIONS: Use to bring up the user preference menu in the display.
7. LAMP: Press to turn the oven light on or off.
8. OVEN OFF: Press to cancel all oven operations except the clock and timer.
9. CONVECTION BAKE: Use to select the Convection bake function of the oven.
10. CONVECTION ROAST: Use to select the Convection roast function of the oven.
11. BAKE: Use to select the bake function of the oven.
12. BROIL: Use to select the broil function of the oven.
13. FAVORITE COOK: Use to save or recall a favorite cooking mode.
14. TEMP PROBE: Use to activate the temp probe mode.

15. KEEP WARM: Use to select the keep warm function of the oven to keep cooked foods warm.
16. SELF CLEAN: Use to select the Self-cleaning function of the oven.
17. HEALTHY COOK: Press to recall the healthy cook recipe setting of the oven.
18. BREAD PROOF: Use to select the Bread proof function.
19. STEAM CLEAN: Use to select the steam cleaning function of the oven.
20. HI+/LO-: Use to raise or lower the temperature and increase or decrease times.
21. NUMBER PAD: Use to set any function requiring numbers such as the time of day on the clock, the timer, the oven temperature, the start time and length of operation for timed baking.
22. CLEAR: Use to cancel previously entered temperature or times.
23. OVEN START/SET: Use to start any cooking or cleaning function in the oven.
24. CONTROL LOCKOUT: Use to disable all oven functions.
25. TOUCH TO WAKE-UP: Press to activate buttons and functions on the display

USING THE OVEN RACKS

Oven rack positions

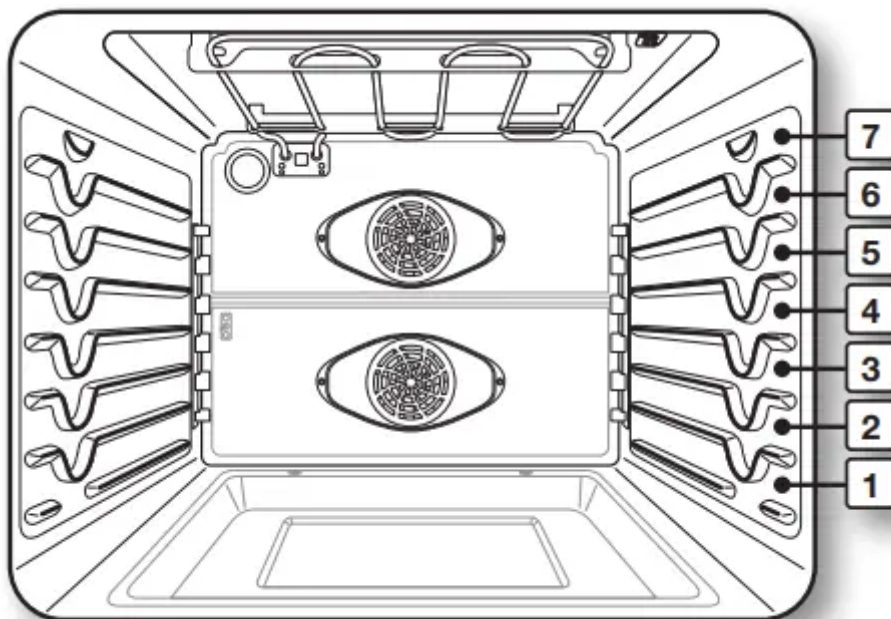

The single oven has 7 rack positions (1~7)

TYPE OF FOOD	RACK POSITION
Muffins, Brownies, Cookies, Cupcakes, Layer cakes, Pies, Biscuits	4
Frozen pies	4
Casserole	4
Bundt or pound cakes	3
Angel food cakes	2
Small roast, hams	2
Turkey, Large roast	1

- This table is for reference only.

Recessed rack position

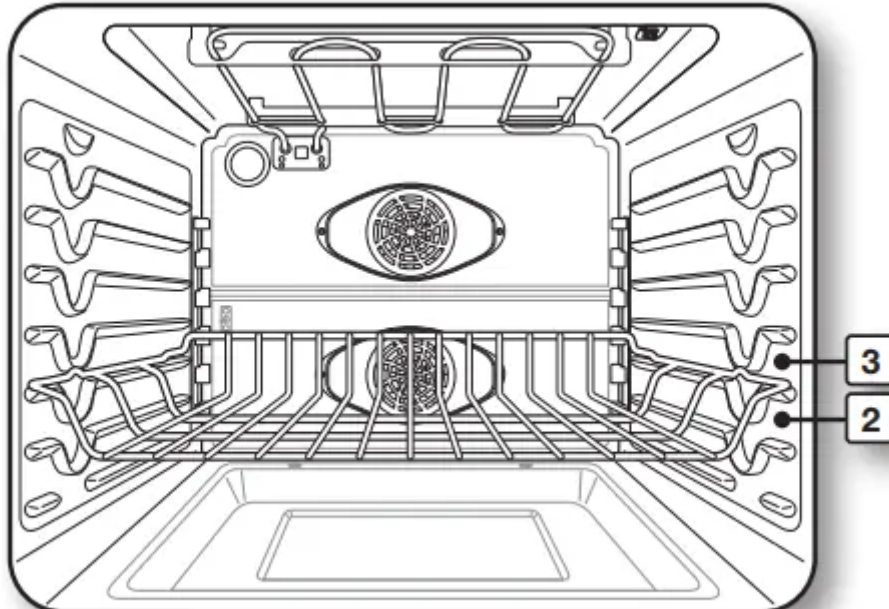

If you use Recessed rack, the recessed ends must be placed in the rack position above the desired position of the food. See the following figure.

These rack positions are for flat racks. If recessed rack is used, the rack position must be adjusted as shown in the previous figure.

Rack and Pan Placement

Centering the baking pans in the oven as much as possible will produce better results. If baking with more than one pan, place the pans so each has at least 1" to 1½" of air space around it.

If baking on two racks, place the oven racks in positions 2 and 4 or 2 and 5. For the best performance, place the oven racks in positions 2 and 4 when baking cakes on multiple racks.

When baking cookies on multiple racks, place the oven racks in positions 2 and 5. Place the pans or cookware as show in the figures below.

When baking on single oven rack, place the oven rack in position 3 or 4.

Using Multiple Oven Racks

Type of Baking	Rack positions
Cakes	2 and 4
Cookies	2 and 5

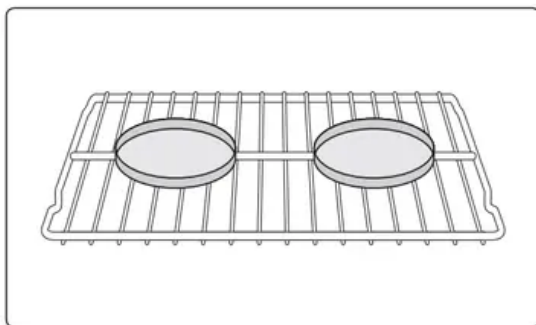

Single Oven Rack

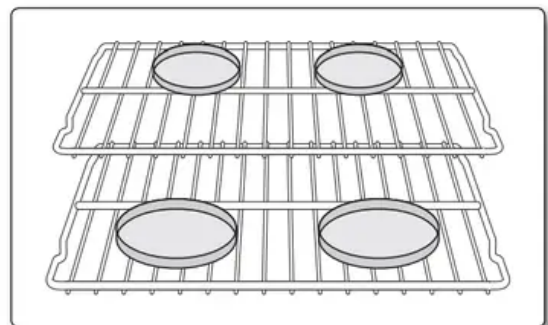

Multiple Oven Rack

Before using the racks

The oven has three racks.

Each rack has stoppers that need to be placed correctly on the supports. These stoppers will keep the rack from coming completely out.

CAUTION



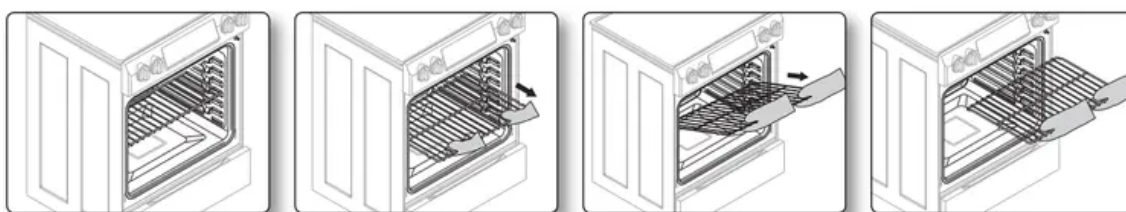



- Do not cover a rack with aluminum foil or place on the oven bottom. This will hamper the heat circulation, resulting in poor baking, and may damage the oven bottom.
- Arrange the oven racks only when the oven is cool.



MINIMUM AND MAXIMUM SETTINGS

All of the features listed in the table below have minimum and maximum time or temperature settings.

A beep will sound each time you press a pad on the control panel and the entry is accepted. An error tone will sound in the form of a long beep if the temperature or time you entered is below the minimum or above the maximum setting for the feature.

FEATURE	MINIMUM	MAXIMUM
 Bake	175 °F (80 °C)	550 °F (287 °C)
 Broil	LO	HI
 Convection Bake	175 °F (80 °C)	550 °F (287 °C)
 Convection Roast	175 °F (80 °C)	550 °F (287 °C)
 Self Clean	3 Hr.	5 Hr.
 Steam Clean	20 Min.	20 Min.
 Keep Warm	-	3 Hr.

BAKING

The oven can be programmed to bake at any temperature from 175 °F to 550 °F.

Baking temperature and time will vary depending on the ingredients, size and shaped of the baking pan used.

Dark or nonstick coatings may be cooked food faster with more browning.

How to set the temperature

1. Start the set up.
Press Bake. The default temperature is 350 °F.
2. Enter the temperature you want on the number pad, eg. 3, 7, 5.
3. Start the bake function.
Press Oven Start/Set. The temperature display will start to change once the oven temperature reaches 175 °F.
4. If you want to cancel baking or if you have finished, press Oven Off.

Place food in the oven after preheating if the recipe calls for it. Preheating is very important for good results when baking cakes, cookies, pastry, and breads. After the oven has reached the desired temperature, a long beep will sound 6 times.

How to adjust the temperature while cooking

1. Start the set up. Press Bake. The display will show the present temperature, eg. 375 °F.
2. Enter the temperature you want, eg. 425 °F, using the number pad.
3. Complete the entry by pressing Oven Start/Set.

If you leave the oven door open for more than 2 minutes when the oven is on, all heating elements will shut off automatically.

When you have finished cooking, the cooling fan will continue to run until the oven has cooled down.

For performance reasons, the convection fan may be turned on or off during the operation.

CONVECTION BAKING

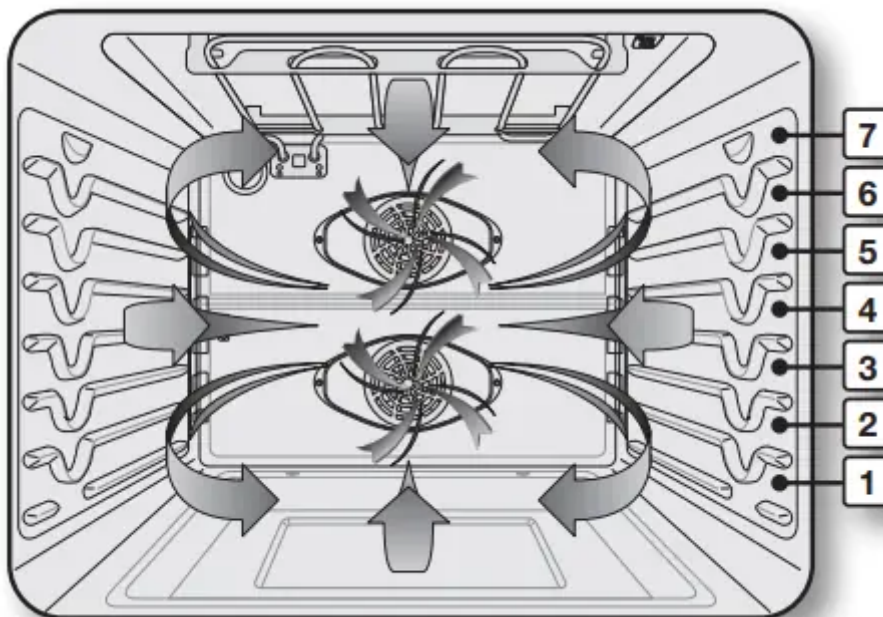

By using the convection bake feature, you will be able to cook faster. You can program the oven for convection baking at any temperature between 175 °F and 550 °F.

Convection baking uses a fan to circulate the oven's heat evenly and continuously within the oven. This improved heat distribution allows for even cooking and excellent results using multiple racks at the same time. Foods cooked on a single oven rack will generally cook faster and more evenly with convection baking. Multiple oven rack cooking may slightly increase cook times for some foods, but the overall result is time saved. Breads and pastries brown more evenly

Tip for convection baking

The amount of time you save will vary depending on the amount and type of food you are cooking. When baking cookies or biscuits, you should use pans with no sides or very low sides to allow the heated air to circulate around the food. Using a pan with a dark finish will allow faster cooking times.

When using convection baking with a single rack, place the oven rack in position 4. If cooking on multiple racks, place the oven racks in positions 2 and 5 (when baking cookies) or 2 and 4 (when baking cakes).

How to set the oven for convection baking

1. Start the convection baking mode.

Press  Bake. The default temperature is 350 °F.

2. Enter the temperature you want, eg. 400 °F, using the number pad. Set the temperature that is called for in the recipe.

3. Press Oven Start/Set to begin convection baking.

The Conv.Bake icon and the adjusted oven temperature, eg. 400 °F, will appear in the display for 2 seconds.

The temperature display will start to change once the oven temperature reaches 175 °F. A beep will sound 6 times when the oven reaches the adjusted oven temperature.

4. To turn off or cancel convection baking, press Oven Off.

The convection oven fan shuts off when the oven door is opened. DO NOT leave the door open for long periods of time while using convection cooking or you may shorten the life of the convection heating element.

If you leave the oven door open for more than 2 minutes when the oven is on, all heating elements will shut off automatically.

When you have finished cooking, the cooling fan will continue to run until the oven has cooled down.

For performance reasons, the convection fan may be turned on or off during the operation.

Convection roasting is good for cooking large tender cuts of meat, uncovered.

Heat comes from the top heating element. The convection fan circulates the heated air evenly over and around the food. Meat and poultry are browned on all sides as if they were cooked on a rotisserie. The heated air seals in juices quickly for a moist and tender product while, at the same time, creating a rich golden brown exterior.

How to set the oven for convection roasting

1. Start the convection roasting mode.

Press  Roast. The default temperature is 350 °F.

2. Enter the temperature you want, eg. 400 °F, using the number pads.
3. Press Oven Start/Set to begin convection roasting.
The Conv.Roast icon and the adjusted oven temperature, eg. 400 °F, will appear in the display for 2 seconds.
The temperature display will start to change once the oven temperature reaches 175 °F.
A beep will sound 6 times when the oven reaches the adjusted oven temperature.
4. Turn off or cancel convection roasting by pressing Oven Off.

The convection oven fan shuts off when the oven door is opened. DO NOT leave the door open for long periods of time while using convection cooking or you may shorten the life of the convection heating element.

If you leave the oven door open for more than 2 minutes when the oven is on, all heating elements will shut off automatically.

When you have finished cooking, the cooling fan will continue to run until the oven has cooled down.

For performance reasons, the convection fan may be turned on or off during the operation.

TIMED COOKING

In timed cooking, the oven turns on immediately and cooks for the length of time you select. At the end of the cooking time, the oven turns off automatically.

- You can use the cooking time feature only with another cooking operation (Bake, Convection Bake, Convection Roast, Healthy Cook, or Favorite Cook).

How to set the oven for timed cooking

1. Enter the set up.
Press the pad for the cooking operation you want, eg. Conv.bake. The default temperature is 350 °F.
2. Enter the temperature you want, eg. 375 °F, using the number pad.
3. Press Cooking Time.
4. Enter the cooking time you want, eg. 45 min, using the number pad.
You can set the cooking time for any amount of time from 1 minute to 9 hours and 99 minutes.
5. Press Oven Start/Set to begin cooking.
The temperature display will start to change once the oven temperature reaches 175 °F.
The oven will continue to cook until the set amount of time has elapsed, then turn off automatically unless the keep warm feature was set. (Refer to the section on the keep warm function on page 50.)
6. You can cancel a cook time at any time by pressing Oven Off.

Place food in the oven after preheating if the recipe calls for it. Preheating is important for good results when baking cakes, cookies, pastry, and breads. After the oven has reached the desired temperature, a long beep will sound 6 times.

CAUTION

Use caution with the cooking time or delay start features. Use these features when cooking cured or frozen meats and most fruits and vegetables. Foods that can easily spoil, such as milk, eggs, fish, meat, or poultry, should be chilled in the refrigerator first. Even when chilled, they should not stand in the oven for more than 1 hour before cooking begins, and should be removed promptly when cooking is completed. Eating spoiled food can result in sickness from food poisoning.

DELAY START

In a delay timed cooking, the oven's timer turns the oven on and off at times you select in advance.

- You can use the delay start feature only with another cooking operation (Bake, Convection Bake, Convection Roast, Healthy Cook, or Favorite Cook).
- You can set the oven for a delay start before setting other cooking operations.
- The clock must be set to the current time.

How to set the oven for delay start

1. Position the oven rack(s) and place the food in the oven.
2. Enter the set up. Press the pad for the cooking operation you want, eg. Conv.bake. The default temperature is 350 °F.
3. Use the number pad to enter the temperature you want, eg. 375 °F.
4. Press Cooking Time.
5. Enter the cooking time you want, eg. 45 minutes, using the number pad. You can set the cooking time for any amount of time from 1 minute to 9 hours and 99 minutes.
6. Press Delay Start.
7. Enter the time you want the oven to turn on, eg. 4:30, using the number pad.
8. Press Oven Start/Set.

At the set time, a short beep will sound. The oven will begin to bake. When the oven has reached the desired temperature, a long beep will sound 6 times.

Place food in the oven after preheating if the recipe calls for it. Preheating is important for good results when baking cakes, cookies, pastry, and breads. After the oven has reached the desired temperature, a long beep will sound 6 times.

BROILING

Broil mode is best for meats, fish, and poultry up to 1" thick. Broiling is a method of cooking tender cuts of meat by direct heat under the broil element of the oven. The high heat cooks quickly and gives a rich, brown outer appearance. Temp probe cannot be used with this mode.

How to set the oven for broiling

1. Select the broil setting you want.

Press Broil.

You can select Hi or Lo by pressing Hi+ or Lo-.

Use Lo to cook foods such as poultry or thick cuts of meat thoroughly without over-browning them.

2. Start the broiling function.

Press Oven Start/Set.

Broil one side until the food is browned. Turn over and broil the other side.

3. Press Oven Off once you have finished cooking or if you want to cancel broiling

This oven is designed for CLOSE DOOR broiling. The oven door must be closed during broiling.

If you leave the oven door open for more than 2 minutes when the oven is on, all heating elements will shut off automatically.

When you have finished cooking, the cooling fan will continue to run until the oven has cooled down.

CAUTION

Always use this cooking mode with the oven door closed.

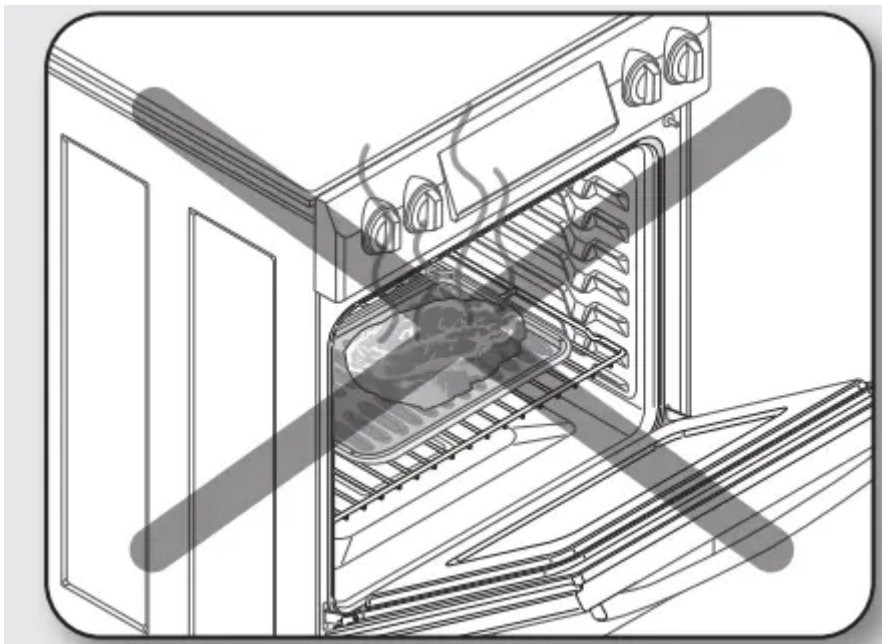

CAUTION

Use care when opening the door. Let hot air or steam escape before you remove food from or put food into the oven.

Broiling Recommendation Guide

The size, weight, thickness, starting temperature, and your doneness preference will affect broiling times.

This guide is based on meats at refrigerator temperature. Always use a broiler pan and its grid when broiling. Always preheat the oven for 5 minutes before broiling.

Food	Doneness	Size	Thickness	Rack position	Cooking time	
					1st side	2nd side
Hamburgers	Medium	9 patties	3/4"	6	3:00	2:30
	Medium	9 patties	1"	6 (or 7)	3:30	3:00
	Medium	16 patties	1"	6	4:00	3:00
Toasts	-	9 toasts	-	5	0:50	0:35

Food	Doneness	Size	Thickness	Rack position	Cooking time	
					1st side	2nd side
Beef steaks	Rare	-	1"	5	5:00	3:30-4:00
	Medium	-	1-1½"	5	7:00	5:00-6:00
	Well done	-	1½"	5	8:00	6:00-7:00
Chicken pieces	Well done	4.5 lbs.	1/2-3/4"	2	18:00-20:00	11:00-15:00
	Well done	2-2½ lbs.	1/2-3/4"	2	13:00-15:00	8:00-11:00
Pork chops	Well done	1 lb.	1/2"	3 or 2	9:00-10:00	7:00-9:00
Lamb chops	Medium	10-12 oz.	1"	3 or 2	5:00	4:00-5:00
	Well done	1 lb.	1½"	3 or 2	7:00	6:00-8:00
Fish fillets	Well done	-	1/4-1/2"	3 or 2	5:00-9:00	3:00-4:00
Ham slices (precooked)	-	-	1/2"	3 or 2	5:00	4:00

USING THE FAVORITE COOK FEATURE

The favorite cook feature lets you record up to 3 different recipe settings. You can use the favorite cook feature for baking, convection baking, or convection roasting. It will not work with any other function, including the delay start feature.

How to record a recipe setting

1. Press the pad for the cooking operation you want to store, eg. Bake. The default temperature is 350 °F.
2. Use the number pad to enter the temperature you want, eg. 375 °F.
3. Press Cooking Time.
4. Enter the cooking time you want, eg. 45 min, using the number pad.



5. You can store a recipe setting in one of three favorite cook positions. Press Favorite Cook the number of times that corresponds to the position in which you want to store the setting. eg. for Favorite Cook position 2, press Favorite Cook twice.
Recipe settings can be stored at position 1, 2, or 3.
6. Press OVEN START/SET.

How to recall a setting

1. Press Favorite Cook the number of times that corresponds to the position in which the recipe setting is stored, eg. for Favorite Cook position 2, press Favorite Cook twice.
2. Start the stored cooking operation. Press Oven Start/Set.

USING THE HEALTHY COOK FEATURE

1. Rice casserole

The Rice casserole feature provides a healthier cooking method for cooking rice casseroles containing vegetables, herbs, chicken breasts, etc.

When using this function, you do not need to preheat the oven prior to cooking. The cooking temperature and cooking time depends on the quantity and material.

How to set the Rice casserole function

1. Press Healthy Cook. The default temperature is 375 °F.
2. Press 1 (Rice casserole) on the number pad. Enter the temperature you want on the number pad.
3. Press Oven Start/Set to begin rice casserole cooking.

For the best results, cook rice casseroles with toppings uncovered, and stews and braised meats covered to prevent evaporation.

2. Baked potato

Baked potato mode is specially designed to bake potatoes or sweet potatoes.

When using this function, you do not need to preheat the oven prior to cooking.

How to set the Baked potato function

1. Press Healthy Cook. The default temperature is 375 °F.
2. Press 2 (Baked potato) on the number pad.
Enter the temperature you want on the number pad.
3. Press Oven Start/Set.

3. Grilled chicken

Grilled chicken mode is specially designed to cook chicken pieces or chicken breasts.

When using this function, you do not need to preheat the oven prior to cooking. If you want to prevent over browning and drying of the skin, cover the breast with foil.

How to set the Grilled chicken function

1. Press Healthy Cook. The default temperature is 350 °F.
2. Press 3 (Grilled chicken) on the number pad.
Enter the temperature you want on the number pad.

4. Salmon steak

This feature is specially designed to cook salmon steaks.

When using this function, you do not need to preheat the oven prior to cooking. The temperature and cooking time depend on the quantity and thickness.

How to set the Salmon steak function

1. Press Healthy Cook. The default temperature is 350 °F.
2. Press 4 (Salmon steak) on the number pad. Enter the temperature you want on the number pad.
3. Press Oven Start/Set.

5. White fish fillet

This feature is specially designed to cook white fish fillets.

When using this function, you do not need to preheat the oven prior to cooking. The temperature and cooking time depend on the quantity and thickness.

How to set the White fish fillet function

1. Press Healthy Cook. The default temperature is 375 °F.
2. Press 5 (White fish fillet) on the number pad. Enter the temperature you want on the number pad.
3. Press Oven Start/Set.

Healthy Cook Recommendation Guide

The guide below contains recommendations for using the Healthy Cook feature.

This chart is for reference only. When using this function, you do not need to preheat the oven prior to cooking

Food	Quantity	Rack Position	Default Temp. (°F)	Oven Temp. (°F)	Cooking Time (min)	Recommendations
Rice casserole	17.5 oz (500 g)	4	375	375 to 425	40-50	Put a cup of instant rice, some vegetables (carrot, onion, zucchini, eggplant, etc.) and chicken breasts into a baking dish. Pour a cup of hot consomme into the baking dish and cover it with a lid or foil. To prevent the bottom from over cooking, do not use an enamel or iron baking dish.
Baked potato	6 ea	3	375	375 to 425	30-40	Put 6 potatoes on a tray or baking dish. Do not cut the potatoes in half. Season the potatoes after cooking if desired.
Salmon steak	3 pieces 19.5 oz (550 g)	5	350	350 to 425	30-40	Put the salmon steaks on a tray or baking dish. Season the salmon after cooking if desired.
Grilled chicken	Chicken Pieces 1-1.2 kg	2	350	350 to 425	30-40	Put the chicken pieces on a tray or baking dish. Season the chicken after cooking if desired.
	Chicken Breast 4-6 pieces	2	350	350 to 425	30-40	Put the chicken breasts (thickness 1/8 to 4/10 inch) on a broiler pan or baking dish. Season the chicken after cooking if desired. To prevent the chicken from over browning or drying out, cover the chicken with aluminum foil.

Food	Quantity	Rack Position	Default Temp. (°F)	Oven Temp. (°F)	Cooking Time (min)	Recommendations
White fish fillet	4 fillets (550 g)	5	375	350 to 425	20-30	Put the fish fillets on a broiler pan or baking dish. Season the fish after cooking if desired. To prevent the fish from over browning or drying out, cover the fish with aluminum foil.

USING THE KEEP WARM FUNCTION

The keep warm feature maintains an oven temperature of 170 °F and will keep cooked food warm for serving up to 3 hours after cooking has finished.

After 3 hours, the feature will shut the oven off automatically. The feature may be used without any other cooking operations or may be set to activate after a timed or delay timed cooking operation.

You should not use this feature to reheat cold foods.

How to use the Keep Warm function

1. Press Keep Warm.
2. Press Oven Start/Set.
3. Press Oven Off at any time to turn the feature off.

How to set the oven to activate the keep warm mode after a timed cooking

1. Set up the oven for Timed Cooking. (Refer to the section on Timed Cooking on page 44.)
2. Press Keep Warm before pressing Oven Start/Set to begin cooking.
3. Press Oven Off at any time to turn the feature off.

USING THE BREAD PROOF FUNCTION

The Bread Proof function automatically provides the optimum temperature for the bread proof process, and therefore does not have a temperature adjustment.

If you press Bread Proof when the oven temperature is above 100 °F, Hot will appear in the display. Because these functions produce the best results when started while the oven is cool, we recommend that you wait until the oven has cooled down and Hot disappears from the display.

1. Press Bread Proof.
2. Press Start/Set.
3. Press Oven Off at any time to turn off the Bread Proof feature.

USING THE OPTIONS FUNCTION

This function enables you to control various electronic control options. These options include temp adjust, temp unit, auto conversion, 12 hour time of day or 24 hour time of day, 12 hour energy saving, language, sound on/off, and demo mode.

The option menu is only available when the oven is not being used (not cooking).

Options	Feature
1. Temp Adjust	Lets you correct the temperature in the oven.
2. Temp Unit	Lets you program the oven control to display temperatures in Fahrenheit or Centigrade.
3. Auto Conversion	The convection auto conversion feature automatically converts entered regular baking temperatures to convection baking temperatures.
4. Time of Day	Lets you set the clock to display the time of day in the 12 hour or 24 hour mode.
5. 12 hour energy saving	This feature automatically turns off the oven after 12 hours during baking functions or after 3 hours during a broil function.
6. Language	Lets you select English, French, or Spanish.
7. Sound On/Of	Lets you set the oven controls to operate silently.
8. Demo mode	This option is for use by retail establishments for display purposes only

Temp Adjust

The temperature in the oven has been calibrated at the factory. When first using the oven, be sure to follow recipe times and temperatures. If you think the oven is too hot or too cool, you can correct the temperature in the oven. Before correcting, test a recipe by using a temperature setting that is higher or lower than the recommended temperature. The baking results should help you to decide how much of an adjustment is needed.

The oven temperature can be adjusted ± 35 °F (± 19 °C).

How to correct the oven temperature

1. Press Options and 1 on the number pad.
2. Press Hi+ or Lo- to select higher or lower than the recommended temperature.
3. Enter the adjustment you want using the number pad. (0~35)
4. Press Oven Start/Set to save the changes.

This adjustment will not affect the broiling or the self-cleaning temperatures. The adjustment will be retained in memory after a power failure.

Temp Unit (Fahrenheit or Celsius temperature selection)

You can program the oven control to display temperatures in Fahrenheit or Centigrade. The oven has been preset at the factory to display in Fahrenheit.

How to change the display from Fahrenheit to Celsius or Celsius to Fahrenheit

1. Press Options and 2 on the number pad.
2. Press 1 (Fahrenheit) or 2 (Celsius) on the number pad.
3. Press Oven Start/Set to save the changes.

Auto Conversion

When you use the auto conversion feature, the convection auto conversion feature will automatically convert entered regular baking temperatures to convection baking temperatures. If this feature is activated, the display will show the actual converted (reduced) temperature. For example, if you enter a regular recipe temperature of 350 °F and press Oven Start/Set, the display will show the converted temperature of 325 °F. (Default setting : off)

How to enable or disable the auto conversion feature

1. Press Options and 3 on the number pad.
2. Press 1 (Off) or 2 (On) on the number pad.
3. Press Oven Start/Set to save the changes.

Time of Day (12hr/24hr)

The oven control can be programmed to display time of day in the 12 hour or 24 hour mode.

The oven has been preset at the factory to display in the 12 hour mode.

How to change between the 12 and 24 hour time of day display

1. Press Options and 4 on the number pad.
2. Press 1 (12hr) or 2 (24hr) on the number pad.
3. Press Oven Start/Set to save the changes.

12 hour energy saving

If you accidentally leave the oven on, this feature will automatically turn off the oven after 12 hours during baking functions or after 3 hours during a broil function.

How to turn the 12 hour energy saving feature on or off

1. Press Options and 5 on the number pad.
2. Press 1 (Off) or 2 (On) on the number pad.
3. Press Oven Start/Set to save the changes.

Language

You can select English, French, or Spanish. The default setting is English.

How to change the language on the display

1. Press Options and 6 on the number pad.
2. Press 1 (EN), 2 (FR) or 3 (SP) on the number pad.
3. Press Oven Start/Set to save the changes.

Sound On/Off

Using Sound On/OFF, you can set the oven controls to operate silently.

How to turn the sound on or off

1. Press Options and 7 on the number pad.
2. Press 1 (Off) or 2 (On) on the number pad.
3. Press Oven Start/Set to save the changes.

Demo mode

This option is for use by retail establishments for display purposes only. (The heating element does not operate.)

How to enable or disable the demo mode

1. Press Options and 8 on the number pad.
2. Press 1 (Off) or 2 (On) on the number pad.
3. Press Oven Start/Set to save the changes.

USING THE TEMP PROBE

For many foods, especially roasts and poultry (beef, chicken, turkey, pork, lamb etc), measuring the internal temperature is the best way to determine if the food is properly cooked. The temp probe lets you cook meat to the exact internal temperature you want, taking the guess work out of determining whether a piece of meat is done or not. This function can be used with Bake, Convection Bake, or Convection Roast. After the internal temperature of the food reaches 100 °F, the increasing internal temperature will be shown in the display.

How to use the Temp probe

1. Push the tip of the temp probe into the meat as fully as possible, so that the tip is in the center of the meat.
 - Insert the probe completely into the meat as shown in the illustrations. It should not touch bone, fat, or gristle.
 - If you do not fully insert the probe into the meat, the Temp Probe function will not work correctly because the probe will sense the oven temperature, not the temperature of the meat.

- For bone-in meats, insert the probe into the center of the lowest and thickest portion of the piece.

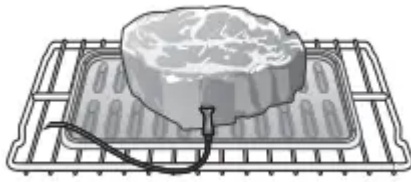

- For whole poultry (turkey, large chickens, etc.), insert the probe into the thickest part of the inner thigh, parallel to the leg.

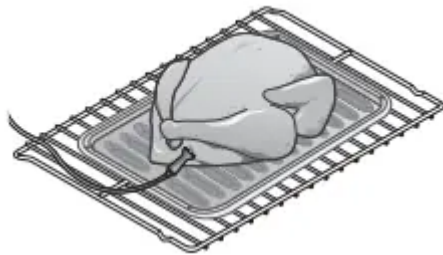

- If you activate the Keep Warm function to keep the meat warm after you have cooked it using the Temp Probe function, the meat's internal temperature will exceed the temperature you want.
2. Insert the temp probe plug into the socket on the top side wall of the oven as far as it will go.
 3. Select the desired cooking function (Conv.Bake, Conv.Roast, Bake) and temperature.
 4. Press Temp Probe to set the desired internal temperature.
 5. Set the desired internal temperature by pressing the number pad.

Available temperatures	100 °F to 200 °F
------------------------	------------------

6. If you want to use the Cook time, Delay start, or Keep warm function, set each function.
7. Press Oven Start/Set.
8. When the desired internal temperature is reached, the function automatically stops and an alarm sounds.

CAUTION

To protect the temp probe's tip, be careful not to insert the probe so that the tip protrudes through the surface of the meat. Make sure that the tip is in or near the center of the meat.

CAUTION

- Do not store the probe in the oven.

- Do not leave the probe inside the oven during a Self-Cleaning or Broiling cycle. You can permanently damage the probe and it will no longer work.
- To avoid breaking the probe's tip, defrost your food completely.
- Do not use tongs when inserting or removing the probe. Tongs can damage the probe.
- Use the temp probe for Temp probe function cooking only. Do not use the temp probe for any other purpose.

If you remove the temp probe while the Temp probe function is operating or insert the temp probe while baking or cooking normally, cooking will stop after 1 minute.

If you use the probe to cook frozen food, there are times when it cannot be detected. (Temp probe icon doesn't show in display.)

Temp probe table

Type of Food		Internal temperature
Beef / Lamb	Rare	140-150 °F
	Medium	160-170 °F
	Well done	175-185 °F
Pork		175-185 °F
Poultry		185-195 °F

If you cover the meat with aluminum foil and allow it to stand for 10 minutes after cooking, the Internal temperature will rise 5-10 degrees.

Removing the Temp probe

Remove the temp probe plug from the socket.

CAUTION

After cooking, the temp probe is hot enough to cause burns.

SETTING THE SABBATH FEATURE

You can use the Sabbath feature for baking only. The oven temperature may be set higher or lower after you have set the Sabbath feature (the oven temperature adjustment feature should be used only during Jewish holidays). The display, however, will not change and tones will not sound when a change occurs. Once the oven is properly set for baking with the Sabbath feature active, the oven will remain continuously on until the Sabbath feature is cancelled. This will override the factory preset 12 hour energy saving feature. If the oven light is needed during the Sabbath, press Oven Light before activating the Sabbath feature. Once the oven light is turned on and the

Sabbath feature is active, the oven light will remain on until the Sabbath feature is turned off. If the oven light needs to be off, be sure to turn the oven light off before activating the Sabbath feature.

How to use the Sabbath feature

1. Press Bake. The default temperature is 350 °F.
2. Enter the temperature you want, eg. 375 °F, by using the number pad.
3. Press Oven Start/Set. The temperature display will start to change once the oven temperature reaches 175 °F.
4. Press Bake and Touch To Wake-Up at the same time for 3 seconds. The display will show SAb. Once SAb appears in the display, the oven control will no longer beep or display any further changes. You may change the oven temperature once baking has started. Remember that the oven control will no longer beep or display any further changes once the Sabbath feature is active.
5. You can turn the oven off at any time by pressing Oven Off. This will turn only the oven off. If you want to deactivate the Sabbath feature, hold down Bake and Touch To Wake-Up at the same time for 3 seconds. Sab will disappear from the display.

Do not attempt to activate any other program feature except Bake while the Sabbath feature is active. ONLY the following key pads will function correctly with the Sabbath feature: Number Pad, Bake, Oven Start/Set and Oven Off. All Other Keypads should not be used once the Sabbath feature is activated.

You can change the oven temperature, but the display will not change and tones will not sound when a change occurs. (the oven temperature adjustment feature should be used only Jewish holidays) After changing the temperature while the unit is in Sabbath mode there is a 15 seconds delay before the unit will recognize the change.

You can set the Cook time function before activating the Sabbath feature.

Should you experience a power failure or interruption, the oven will shut off. When power is returned the oven will not turn back on automatically. SAb will be displayed in the oven control display, but the oven will not operate. The food may be safely removed from the oven while the oven is still in the Sabbath mode, however the oven cannot be turned back on until after the Sabbath/Holidays. After the Sabbath observance turn OFF the Sabbath mode. Press and hold both Bake and Touch To Wake-Up for at least 3 seconds simultaneously to turn the Sabbath mode off. The oven may be used normally.

Do not open the oven door or change the oven temperature for about 30 minutes after you have started Sabbath mode to allow the oven to reach the set temperature. Note that, for best performance, the oven fan operates only when the oven temperature is rising.

Do not use the cooktop when the range is in the Sabbath MODE.

Maintaining your appliance

SELF-CLEANING

This self-cleaning oven uses high temperatures (well above cooking temperatures) to burn off leftover grease and residue completely or reduce them to a finely powdered ash that you can wipe away with a damp cloth.

CAUTION

- During the self-cleaning cycle, the outside of the range will become very hot to the touch. Do not leave small children unattended near the appliance.
- Some birds can be sickened by the fumes given off during the self-cleaning cycle of any range. Move birds to another well-ventilated room.
- Do not line the oven walls, racks, bottom, or any other part of the range with aluminum foil. Doing so will result in poor heat distribution, produce poor baking results, and cause permanent damage to the oven interior. Aluminum foil will melt and adhere to the interior surface of the oven.
- Do not force the oven door open. This can damage the automatic door locking system. Use care when opening the oven door after the self-cleaning cycle is complete. Stand to the side of the oven when opening the door to allow hot air or steam to escape. The oven may still be VERY HOT.

Before a self-cleaning cycle

- We recommend venting your kitchen by opening a window or using a ventilation fan or hood during the self-cleaning cycle.
- Remove the wire rack, broil pan, broil pan insert, all cookware, and any aluminum foil from the oven.

- Wipe up debris from the oven bottom. (Fig. 1)

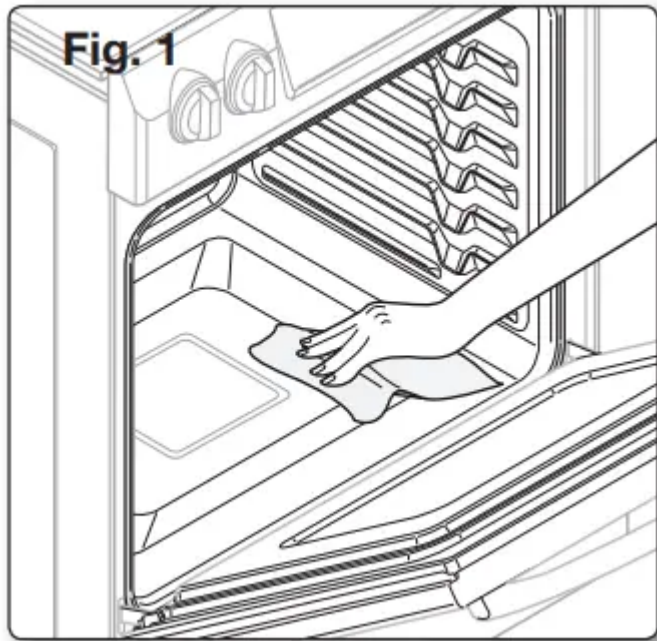

- The silver-colored oven racks can be self-cleaned, but they will darken, lose their luster, and become hard to slide.
- Residue on the front frame of the range and outside the gasket on the door will need to be cleaned by hand. Clean these areas with hot water, soap-filled steel-wool pads, or cleansers such as Soft Scrub. Rinse well with clean water and dry.
- Do not clean the gasket. The fiberglass material of the oven door gasket cannot withstand abrasion. It is essential for the gasket to remain intact. If you notice it becoming worn or frayed, replace it. (Fig. 2)

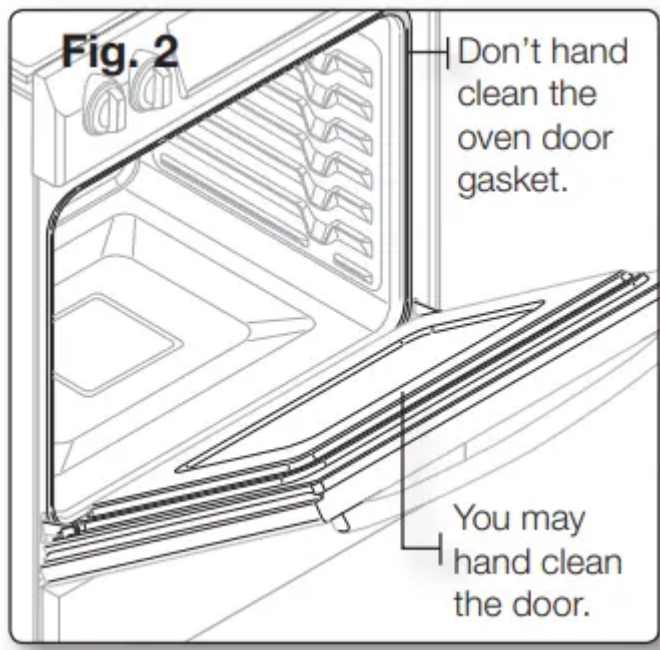

- Make sure the oven light bulb cover is in place and the oven light is off.

Remove oven racks and accessories before starting the self-clean mode.

How to run a self-cleaning cycle

1. Select the length of time for the self-cleaning operation, eg. 3 hours.
Press Self Clean once for a 3 hour clean time, twice for a 4 hour clean time, or 3 times for a 5 hour clean time.
The default setting is 3 hours.
2. Start the self-cleaning cycle. Press Oven Start/Set. The motor-driven door lock will engage automatically.
3. When the self-cleaning cycle is done, End will show in the display and a beep will sound 6 times
 - You will not be able to start a self-cleaning cycle if the control lockout feature is activated or if the oven's temperature is too hot.
 - The oven door locks automatically. The display will show the cleaning time remaining. It is not possible to open the oven door until the temperature drops to a safe/cool temperature

How to delay the start of self-cleaning

1. Press Self Clean. Select the desired self-clean time by pressing Self Clean.
2. Press Delay Start.
3. Enter the time you want the clean cycle to start.
4. Press Oven Start/Set.
The display will show delay start, self clean, and the Lock icon. The motor-driven door lock will engage automatically.
5. The Self-Cleaning cycle will turn on automatically at the set time.

How to turn off the self-cleaning feature

You may find it necessary to stop or interrupt a self-cleaning cycle due to smoke in the oven.

1. Press Oven Off.
2. You will be able to open the oven door once the oven has cooled down for approximately 1 hour.

After a self-cleaning cycle

- You may notice some white ash in the oven. Wipe it up with a damp cloth after the oven cools. (If white spots remain, remove them with a soap-filled steel wool pad and rinse thoroughly with a vinegar and water mixture.)
- If the oven is not clean after one cycle, repeat the cycle.
- You cannot set the oven for cooking until the oven is cool enough for the door to unlock.

STEAM-CLEANING

How to set the oven for steam-cleaning

For light cleaning, the Steam-cleaning function saves time and energy. For heavier-duty cleaning of debris and grease, use the self-cleaning function.

1. Remove all accessories from the oven.
2. Pour approximately 10 oz. (300 ml) of water onto the bottom of the empty oven and close the oven door. Use normal water only, not distilled water.



3. Press Steam Clean.
4. Press Oven Start/Set. When the operation is complete, the display will blink and a beep will sound.
5. Press Oven Off.
6. Clean the oven's interior. There will be a significant amount of water remaining on the bottom of the oven after a steam-cleaning cycle. Remove the residual water with a sponge or soft dry cloth.

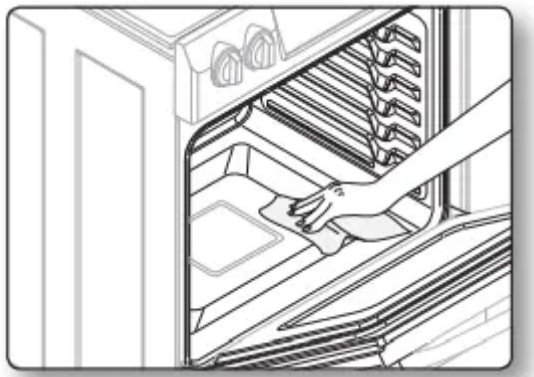

When steam-cleaning, use exactly 10 oz. of water since this produces the best results.

If you press Steam Clean when the oven temperature is above 100 °F, Hot will appear in the display. Because these functions produce the best results when started while the oven is cool, we recommend that you wait until the oven has cooled down and Hot disappears from the display.

After a steam-cleaning cycle

- Take care when opening the door after a steam-cleaning procedure has ended. The water on the bottom is hot.
- Open the oven door and remove the remaining water with a sponge. Do not leave the residual water in the oven for any length of time. Wipe the oven clean and dry with a soft cloth. Do not forget to wipe under the oven door seal.
- Use a detergent-soaked sponge, a soft brush, or a nylon scrubber to wipe the oven interior. Remove stubborn residue with a nylon scourer. You can remove lime deposits with a cloth soaked in vinegar.
- If the oven remains dirty, you can repeat the procedure once the oven has cooled.
- For heavy residue, such as grease left over from roasting, we recommend that you rub detergent into the residue before activating the steam-cleaning function.
- After cleaning, leave the oven door ajar at a 15 ° angle to allow the interior enamel surface to dry thoroughly.

CARE AND CLEANING OF THE OVEN

WARNING

- **Be sure all controls are OFF and all surfaces are COOL before cleaning any part of the range.**
- **If your range is removed for cleaning, servicing, or any reason, be sure the Anti-Tip device is re-engaged properly when the range is replaced. If you fail to reengage the Anti-Tip device, the range could tip and cause serious injury**



Oven vent

- The oven vent is located below the control box.
- This area could become hot during oven use.
- It is normal for steam to come out of the vent.
- The vent is important for proper air circulation. Never block this vent.

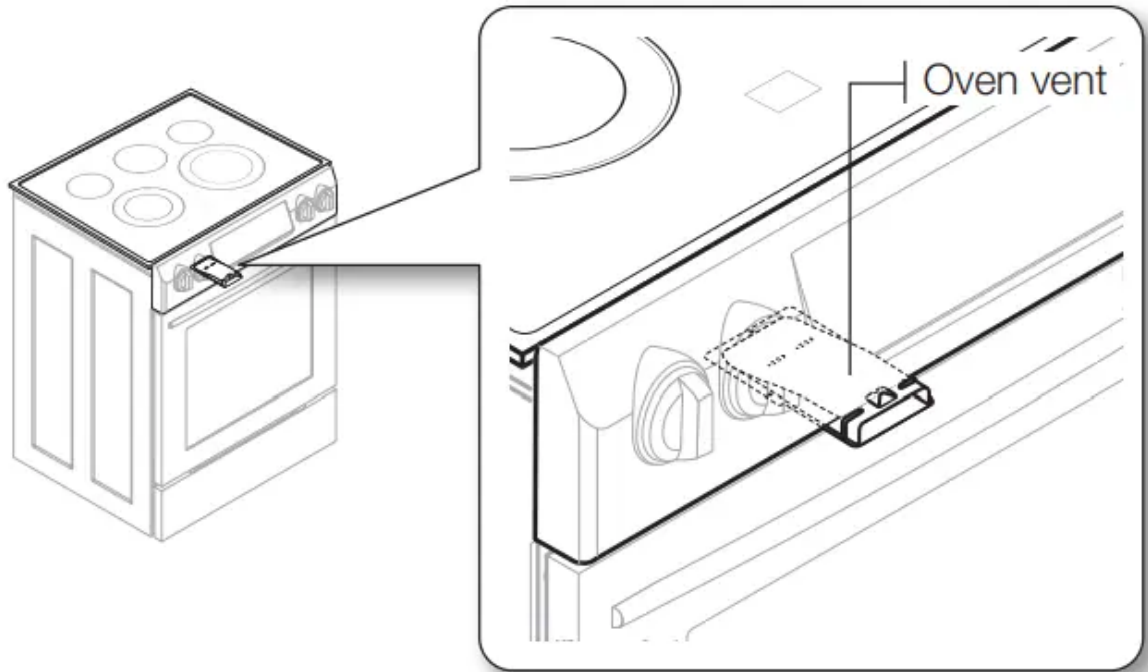

Cleaning painted parts and decorative trim

- For general cleaning, use a cloth with hot and soapy water.
- For more difficult residue and built-up grease, apply a liquid detergent directly onto the area and leave for 30 to 60 minutes. Wipe with a damp cloth and dry. Do not use abrasive cleaners on any of these surfaces. They can scratch.

Cleaning stainless steel surfaces

1. Shake the bottle of Stainless Steel Appliance Cleaner or polish well.
 2. Place a small amount of Stainless Steel Appliance Cleaner or polish on a damp cloth or damp paper towel.
 3. Clean a small area, rubbing with the grain of the stainless steel if applicable.
 4. Dry and buff with a clean, dry paper towel or soft cloth.
 5. Repeat as necessary.
- Do not use a steel-wool pad. It will scratch the surface.
 - If a mineral oil-based stainless steel appliance cleaner has been used before to clean the appliance, wash the surface with dishwashing liquid and water prior to using the Stainless Steel Appliance Cleaner or polish.

Oven racks

- If the racks are left in the oven during a self-cleaning cycle, their color will turn slightly blue and the finish will be dull. After the self-cleaning cycle is complete and the oven has cooled, rub the sides of the racks with wax paper or a cloth containing a small amount of oil. This will help the racks glide more easily into their tracks.

Oven door

- Use soap and water to thoroughly clean the top, sides, and front of the oven door. Rinse well. You may use a glass cleaner on the outside glass of the oven door. DO NOT immerse the door in water. DO NOT spray or allow water or the glass cleaner to enter the door vents. DO NOT use oven cleaners, cleaning powders, or any harsh abrasive cleaning materials on the outside of the oven door.
- DO NOT clean the oven door gasket. The oven door gasket is made of a woven material which is essential for a good seal. Care should be taken not to rub, damage, or remove this gasket.

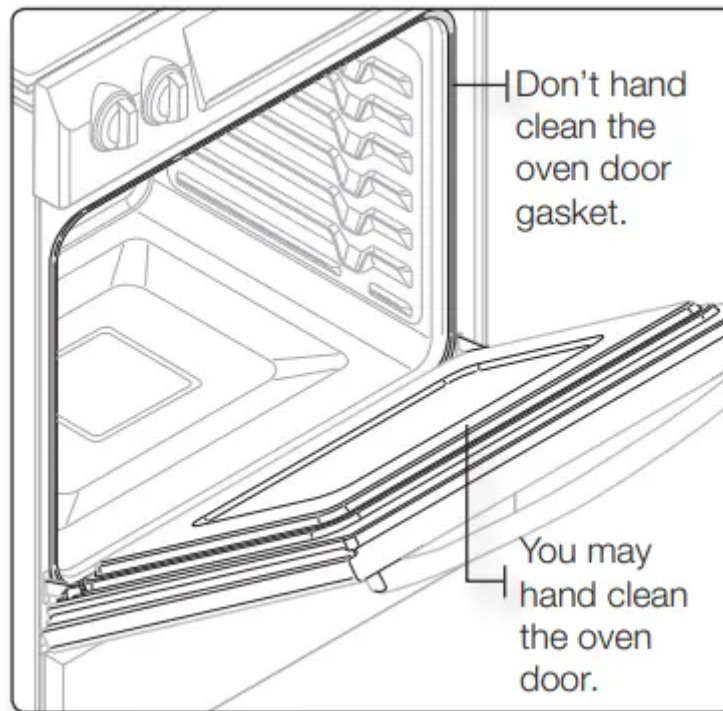

CARE AND CLEANING OF THE GLASS COOKTOP

Normal daily use cleaning

Use only a ceramic cooktop cleaner. Other creams may not be as effective.

By following these steps, you can maintain and protect the surface of your glass cooktop.

1. Before using the cooktop for the first time, clean it with a ceramic cooktop cleaner. This helps protect the top and makes cleanup easier.
2. Daily use of a ceramic cooktop cleaner will help keep the cooktop looking new.
3. Shake the cleaning cream well. Apply a few drops of cleaner directly to the cooktop.
4. Use a paper towel or a cleaning pad for ceramic cooktops to clean the entire cooktop surface.
5. Use a dry cloth or paper towel to remove all cleaning residue. No need to rinse.

WARNING

DAMAGE to your glass surface may occur if you use scrub pads other than those recommended.

Removing burned-on residue

1. Allow the cooktop to cool.
2. Spread a few drops of ceramic cooktop cleaner on the entire burned residue area.
3. Using the cleaning pad for ceramic cooktops, rub the residue area, applying pressure as needed.
4. If any residue remains, repeat the steps listed above as needed.
5. For additional protection, after all residue has been removed, polish the entire surface with ceramic cooktop cleaner and a paper towel.

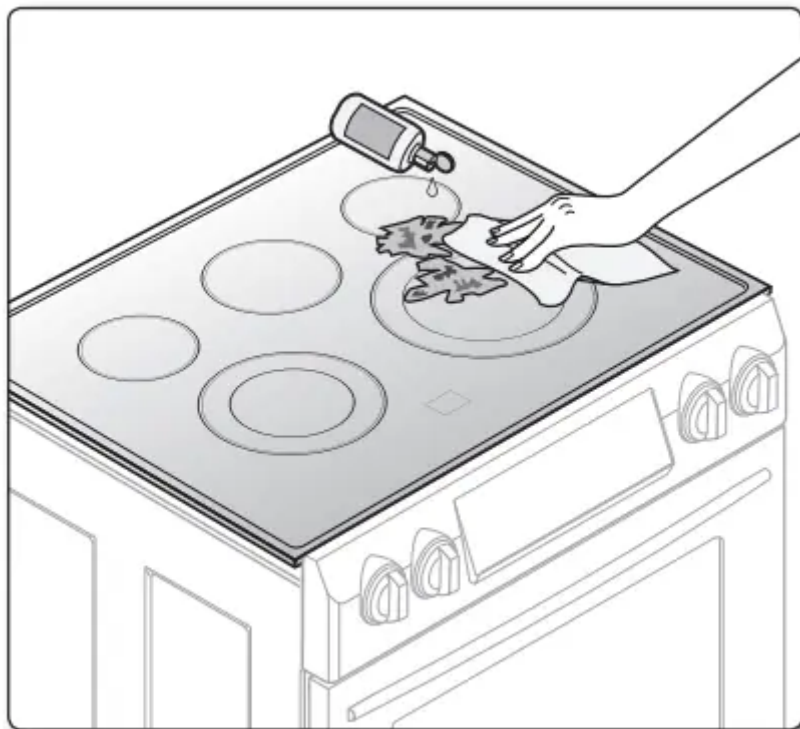

Removing heavy, burned-on residue

1. Allow the cooktop to cool.
2. Use a single-edge razor-blade scraper at approximately a 45 ° angle against the glass surface and scrape the soil. It will be necessary to apply pressure in order to remove the residue.
3. After scraping with the razor scraper, spread a few drops of ceramic cooktop cleaner on the entire burned residue area. Use the cleaning pad to remove any remaining residue. (Do not scrape the seal.)
4. For additional protection, after all residue has been removed, polish the entire surface with the cooktop cleaner and a paper towel.

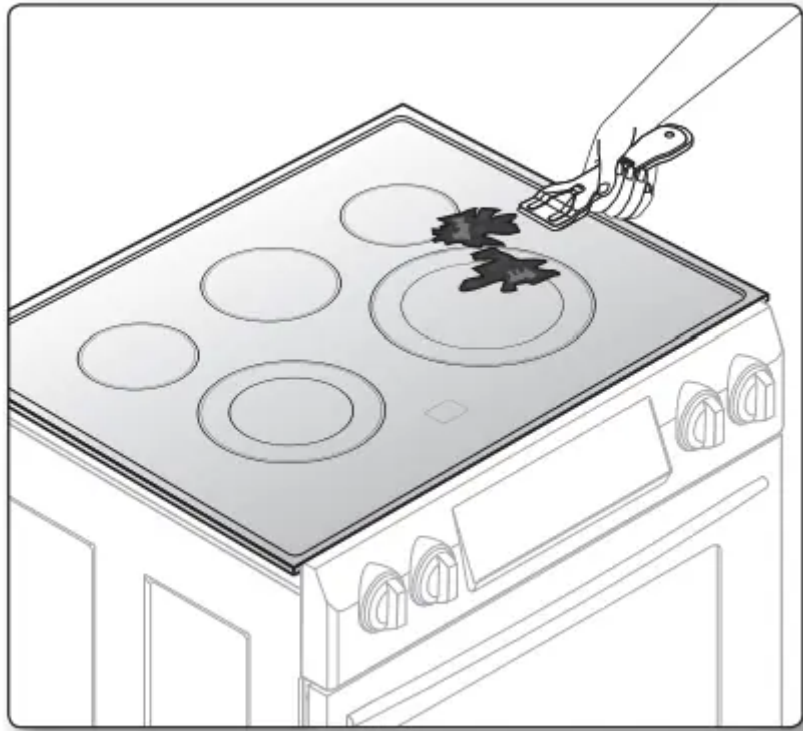

Removing metal marks and scratches

1. Be careful not to slide pots and pans across your cooktop. It will leave marks on the cooktop surface. You can remove these marks by applying ceramic cooktop cleaner with a cleaning pad for ceramic cooktops.
2. If pots with a thin overlay of aluminum or copper are allowed to boil dry, the overlay may leave black discoloration on the cooktop. You should remove this discoloration immediately or it may become permanent.

WARNING

Carefully check the bottoms of pans for roughness that may scratch the cooktop.

Cleaning the cooktop seal

To clean the seal around the edges of the glass, lay a wet cloth on it for a few minutes, then wipe clean with a nonabrasive cleaner.

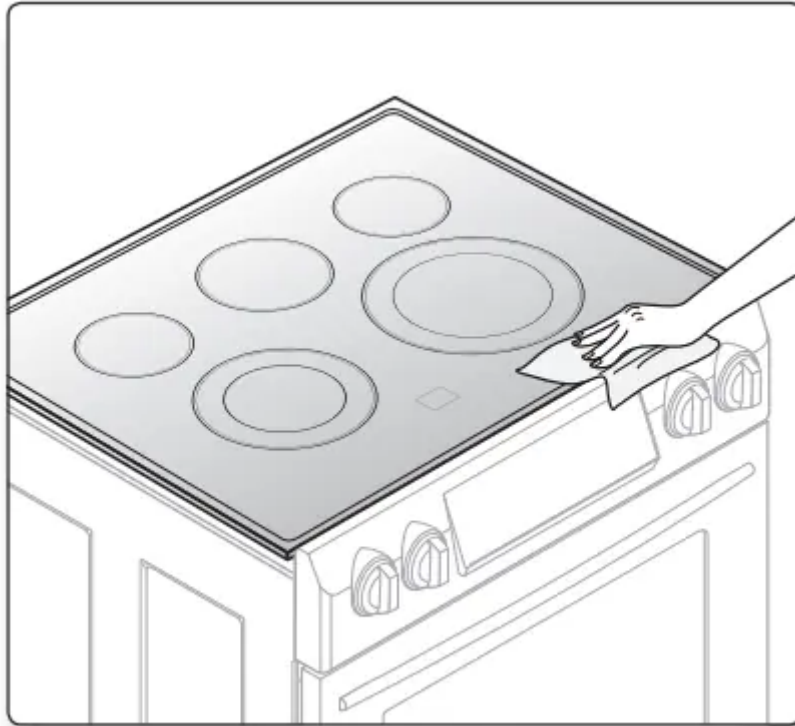

Potential for permanent damage to the glass surface

- Sugary spillovers (such as jellies, fudge, candy, syrups) or melted plastics can cause pitting of the surface of your cooktop. This is not covered under the warranty. You should clean the spill while it is still hot. Take special care when removing hot substances. Refer to the following section.
- When using a scraper, be sure it is new and the razor blade is still sharp. Do not use a dull or nicked blade.

Cleaning sugary spills and melted plastic

1. Turn off all surface units. Remove hot pans.
2. Wearing an oven mitt, use a single-edge razor-blade scraper to move the spill to a cool area of the cooktop. Remove the spill with paper towels.
3. Any remaining spillover should be left until the surface of the cooktop has cooled.
4. Don't use the surface units again until all of the residue has been completely removed.

If pitting or indentations in the glass surface have already occurred, the cooktop glass will have to be replaced. In this case, service will be necessary

REMOVING AND REPLACING THE OVEN DOOR

How to remove the door

CAUTION

- The door is very heavy. Be careful when removing and lifting the door. Do not lift the door by the handle.
 - Turn the power OFF before removing the door.
1. Open the door completely.
 2. Pull the hinge locks down toward the door frame to the unlocked position

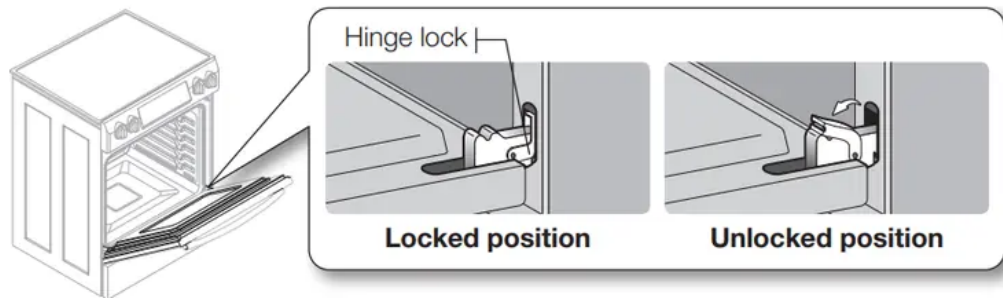

3. Firmly grasp both sides of the door at the top
4. Close the door to the door removal position, which is approximately 5 degrees from vertical (Fig. 1).

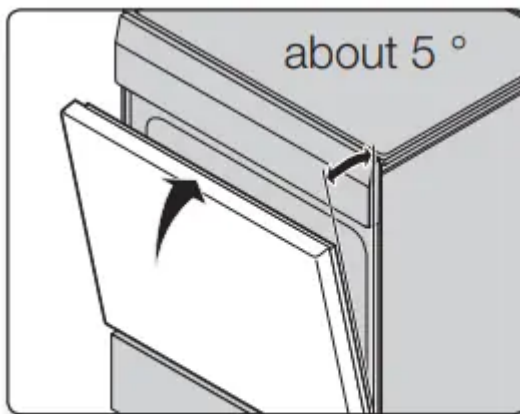

Fig. 1

5. Lift door up and out until the hinge arm is clear of the slot (Fig. 2).

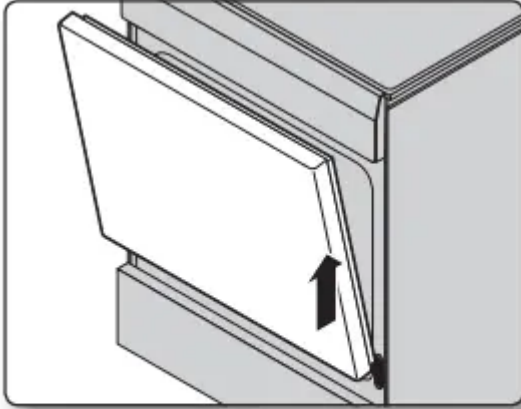
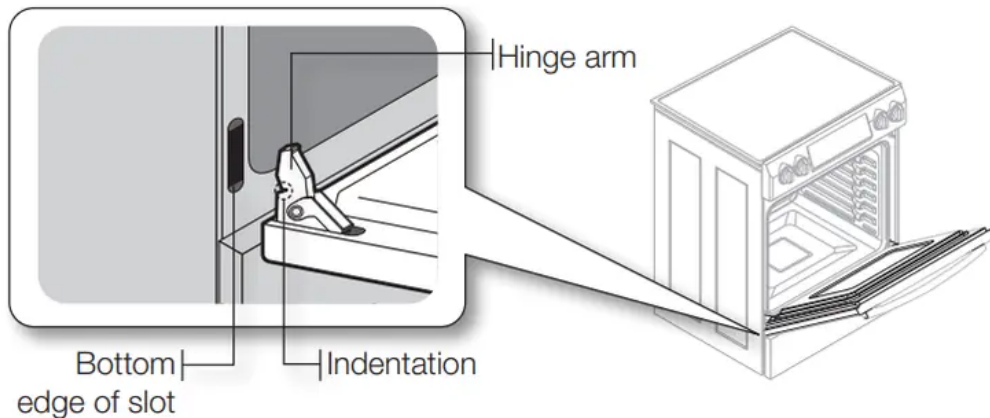

Fig. 2

How to replace the door

1. Firmly grasp both sides of the door at the top.
2. With the door at the same angle as the removal position, slide the indentation of the hinge arm into the bottom edge of the hinge slot. The notch in the hinge arm must be fully inserted into the bottom of the slot.



3. Open the door fully. If the door will not open fully, the indentation is not inserted correctly in the bottom edge of the slot.
4. Push the hinge locks up against the front frame of the oven cavity to the locked position.

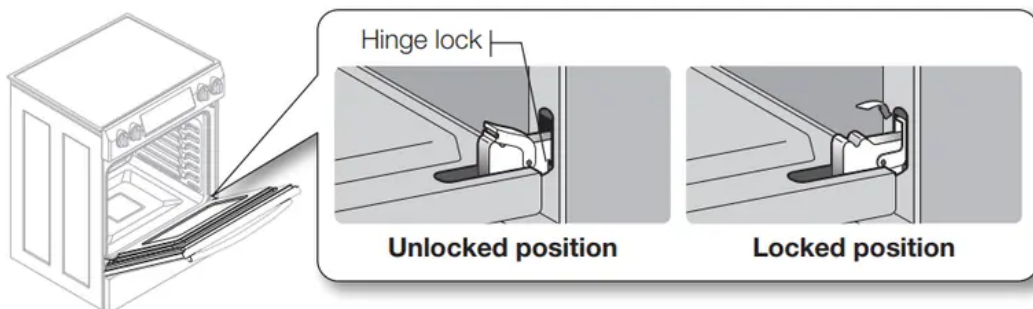

5. Close the oven door.

REMOVING AND REPLACING THE STORAGE DRAWER

How to remove the storage drawer

1. Pull the drawer out until it stops.
2. Tilt the front of the drawer and pull out it until it stops.
3. Lift and pull the drawer out.

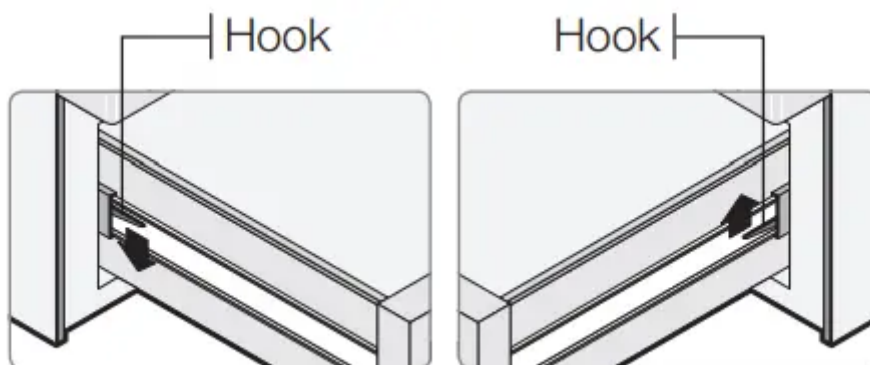

How to replace the storage drawer

1. Put the left side of the drawer over the left hook and the right side over the right hook.
2. Push the drawer until it stops.
3. Tilt and lift the drawer.
4. Push the drawer in.

CHANGING THE OVEN LIGHT

The oven light is a standard 40-watt appliance bulb. It will come on when the oven door is open. When the oven door is closed, press Oven Light to turn it on or off. It will not work during a selfcleaning cycle.

1. Make sure the oven and the bulb are cool.
2. Unplug the range or disconnect the power.
3. Turn the glass bulb cover in the back of the oven counterclockwise to remove.

4. Turn the bulb counterclockwise to remove it from its socket.

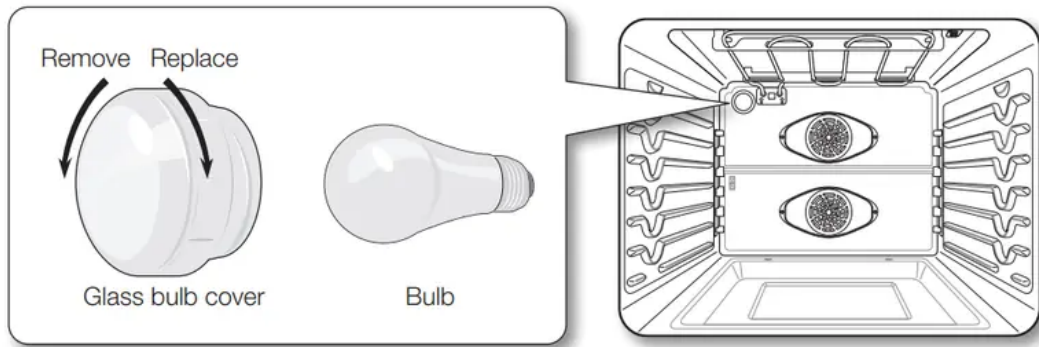

5. Replace the light bulb and glass bulb cover by turning them clockwise.

6. Plug in the range or reconnect power.

CAUTION

Before changing your oven light bulb, disconnect the electrical power to the range at the main fuse or circuit breaker panel. Make sure the oven and the bulb are cool.

TROUBLESHOOTING

Samsung works hard to ensure that you don't have problems with your new electric range. If you run into unexpected trouble, look first for a solution in the table below. If, after trying the suggested solution, you're still having trouble, call Samsung at 1-800-SAMSUNG (1-800-726-7864).

PROBLEM	POSSIBLE CAUSE	SOLUTION
<p>The range is not level.</p>	<p>The appliance has been installed improperly.</p>	<ul style="list-style-type: none"> • Place the oven rack in the center of the oven. Place a level on the oven rack. Adjust the leveling legs at the base of the range until the oven rack is level. • Insure the floor is level and strong and stable enough to adequately support the range.
	<p>The floor is sagging or sloping</p>	<ul style="list-style-type: none"> • Contact a carpenter to correct the situation.
	<p>The kitchen cabinets are not properly aligned and make the range appear to be not level.</p>	<ul style="list-style-type: none"> • Insure the cabinets are square and provide sufficient room for installation.
<p>The appliance must be accessed for servicing and cannot be moved easily.</p>	<p>The kitchen cabinets are not square and built too tightly in to the appliance</p>	<ul style="list-style-type: none"> • Contact a builder or installer to make the appliance accessible.
	<p>Carpet is interfering with movement of the range.</p>	<ul style="list-style-type: none"> • Provide sufficient space so the range can be lifted over the carpet.
<p>The oven control beeps and displays an error code.</p>	<p>You have a function error code.</p>	<ul style="list-style-type: none"> • Press Oven Off and restart the oven. If the problem persists, disconnect all power to the range for at least 30 seconds and then reconnect the power. If this does not solve the problem, call for service.



	CODE	CAUSE	
	E-21	Oven sensor opened	
	E-22	Oven sensor shorted	
	E-24	Oven heating over	
	E-2E	Temp probe error	
	E-0E	Door locking error	
	E-83	Communication error	
	-tE-	Communication error (Touch)	
The surface units will not maintain a rolling boil or will not cook fast enough.	You may be using inappropriate cookware.		<ul style="list-style-type: none"> • Use pans which are flat and match the diameter of the surface unit selected.
	In some areas, the power (voltage) may be low.		<ul style="list-style-type: none"> • Cover the pan with a lid until the desired heat is obtained.
The surface units will not turn on.	A fuse in your home may be blown or the circuit breaker tripped.		<ul style="list-style-type: none"> • Replace the fuse or reset the circuit breaker.
	The cooktop controls are set improperly		<ul style="list-style-type: none"> • Check to see the correct control is set for the surface unit you are using.
The surface unit stops glowing when changed to a lower setting.	This is normal. The unit is still on and hot.		<ul style="list-style-type: none"> • This is normal. The unit is still on and hot.



Areas of discoloration on the cooktop.	Food spillover was not cleaned.	<ul style="list-style-type: none"> • Refer to the section on care and cleaning of the glass cooktop on page 60.
	The surface is hot and the model features a light-colored cooktop.	<ul style="list-style-type: none"> • This is normal. The surface may appear discolored when it is hot. This is temporary and will disappear as the glass cools.
The surface unit frequently cycles on and off.	This is normal.	<ul style="list-style-type: none"> • The element will cycle on and off to maintain the power setting.
The oven will not turn on.	The range is not completely plugged into the electrical outlet.	<ul style="list-style-type: none"> • Make sure the electrical plug is inserted into a live, properly grounded outlet.
	A fuse in your home may be blown or the circuit breaker tripped.	<ul style="list-style-type: none"> • Replace the fuse or reset the circuit breaker.
	The oven controls have been set improperly.	<ul style="list-style-type: none"> • See the chapter on operating the oven.
	The oven is too hot.	<ul style="list-style-type: none"> • Allow the oven to cool.
The appliance will not turn on.	The appliance is not completely plugged into the electrical outlet or a fuse in your home may be blown or the circuit breaker tripped.	<ul style="list-style-type: none"> • Make sure the power cord is plugged into a live, properly grounded outlet. Check the fuse and circuit breakers.
	Incomplete service wiring.	<ul style="list-style-type: none"> • Call for service.
	Power outage.	<ul style="list-style-type: none"> • Check to see if the house lights will turn on. If

		required, call your local electric company for service.
The oven light will not turn on.	The light bulb is loose or defective.	<ul style="list-style-type: none"> • Tighten or replace the bulb.
	The switch operating light is broken.	<ul style="list-style-type: none"> • Call for service.
Oven smokes excessively during broiling.	The control has not been set properly.	<ul style="list-style-type: none"> • Refer to the section on setting oven controls. • Make sure the oven door is opened to the broil stop position.
	The meat has been placed too close to the element.	<ul style="list-style-type: none"> • Reposition the rack to provide proper clearance between the meat and the element. Preheat the broil element for searing.
	The meat has not been properly prepared.	<ul style="list-style-type: none"> • Remove the excess fat from the meat. Cut away fatty edges that may curl, leaving the lean intact.
	Grease has built up on oven surfaces	<ul style="list-style-type: none"> • Regular cleaning is necessary when broiling frequently.
Food does not bake or roast properly	The oven controls have not been set correctly.	<ul style="list-style-type: none"> • See the chapter on operating the oven.
	The oven rack has been positioned incorrectly or is not level.	<ul style="list-style-type: none"> • See the section on using the oven racks on page 40.
	Incorrect cookware or cookware of improper size is being used.	



	The oven sensor needs to be adjusted.	<ul style="list-style-type: none"> • See the section on adjusting the thermostat on page 51.
Food does not broil properly.	The oven controls have been set incorrectly.	<ul style="list-style-type: none"> • Press BROIL.
	The rack has not been properly positioned.	<ul style="list-style-type: none"> • See the broiling recommendation guide on page 46.
	Cookware not suited for broiling.	<ul style="list-style-type: none"> • Use suitable cookware.
	In some areas the power (voltage) may be low.	<ul style="list-style-type: none"> • Preheat the broil element for 10 minutes. • See the broiling recommendation guide on page 46.
The oven temperature is too hot or too cold.	The oven sensor needs to be adjusted.	<ul style="list-style-type: none"> • See the section on adjusting the thermostat on page 51.
Scratches or abrasions on cooktop surface.	The cooktop is being cleaned improperly.	<ul style="list-style-type: none"> • Scratches are not removable. Tiny scratches will become less visible in time as a result of cleaning.
	Cookware with rough bottoms was used on the cooktop or there were coarse particles (eg. salt or sand) present between the cookware and the surface of the cooktop.	<ul style="list-style-type: none"> • To avoid scratches, use the recommended cleaning procedures. Make sure cookware bottoms are clean before use, and use cookware with smooth bottoms.

	Cookware has been slid across the cooktop surface.	<ul style="list-style-type: none"> • To avoid scratches, use the recommended cleaning procedures. Make sure cookware bottoms are clean before use, and use cookware with smooth bottoms.
Brown streaks or specks.	Boilovers have been cooked onto the surface.	<ul style="list-style-type: none"> • Use the blade scraper to remove soil. • See the section on care and cleaning of the glass cooktop on page 60.
Areas of discoloration with metallic sheen.	Mineral deposits from water and food have been left on the surface of the cooktop.	<ul style="list-style-type: none"> • Remove using a ceramic-glass cooktop cleaning cream. • Use cookware with clean, dry bottoms.
The oven will not self-clean.	The oven temperature is too high to set a self-clean operation.	<ul style="list-style-type: none"> • Allow the range to cool and reset the controls.
	The oven controls have been set incorrectly.	<ul style="list-style-type: none"> • See the section on self-cleaning on page 56.
	A self-cleaning cycle cannot be started if the oven lockout feature has been activated or if a radiant surface element is on.	
"Crackling" or "popping" sound.	This is the sound of the metal heating and cooling during both the cooking and cleaning functions.	<ul style="list-style-type: none"> • This is normal.
Excessive smoking during a selfcleaning cycle.	There is excessive soiling in the oven.	<ul style="list-style-type: none"> • Press Oven Off. Open the windows to rid the room of smoke. Wait until the self-cleaning cycle is

		cancelled. Wipe up the excessive soil and reset the oven for self-cleaning.
The oven door will not open after a self-cleaning cycle.	The oven is too hot.	<ul style="list-style-type: none"> • Allow the oven to cool.
Oven not clean after a self-cleaning cycle.	The oven controls were not set correctly.	<ul style="list-style-type: none"> • See the section on self-cleaning on page 56.
	The oven was heavily soiled.	<ul style="list-style-type: none"> • Wipe up heavy spillovers before starting the self-cleaning cycle. Heavily soiled ovens may need to be self-cleaned again or for a longer period of time.
Steam from the vent.	When using the convection feature, it is normal to see steam coming out of the oven vent.	<ul style="list-style-type: none"> • This is normal.
	As the number of racks or amount of food being cooked increases, the amount of visible steam will increase.	
Burning or oily odor emitting from the vent.	This is normal in a new oven and will disappear in time.	<ul style="list-style-type: none"> • To speed the process, set a self-cleaning cycle for a minimum of 3 hours. • See the section on self-cleaning on page 56
Strong odor.	An odor from the insulation around the inside of the oven is normal for the first few times the oven is used.	<ul style="list-style-type: none"> • This is temporary.
Fan noise.	A convection fan may automatically turn on and off.	<ul style="list-style-type: none"> • This is normal

Oven racks are difficult to slide.	The shiny, silver-colored racks were cleaned in a self-cleaning cycle	<ul style="list-style-type: none"> • Apply a small amount of vegetable oil to a paper towel and wipe the edges of the oven racks with the paper towel.
Display goes blank.	A fuse in your home may be blown or the circuit breaker tripped.	<ul style="list-style-type: none"> • Replace the fuse or reset the circuit breaker
Display flashes.	There was a power failure.	<ul style="list-style-type: none"> • Reset the clock
Drawer does not slide smoothly or drags.	The drawer is out of alignment.	<ul style="list-style-type: none"> • Fully extend the drawer and push it all the way in. See the page 64.
	The drawer is over-loaded or the load is unbalanced.	<ul style="list-style-type: none"> • Reduce weight. Redistribute drawer contents.

Warning

This content is compiled from multiple sources and is provided for reference purposes only. It may not be complete or fully applicable to all situations. If you are unable to resolve your issue, please contact the product manufacturer or an authorized service provider for official support.