

USING THE RANGE

Surface Units

How to Set

- Push the knob in and turn in either direction to the setting you want.
- A surface ON indicator light will glow when any surface unit is on

For glass cooktop surfaces:

A HOT COOKTOP indicator light will:

- come on when the unit is hot to the touch.
- stay on even after the unit is turned off.
- stay on until the unit is cooled to approximately 150°F.

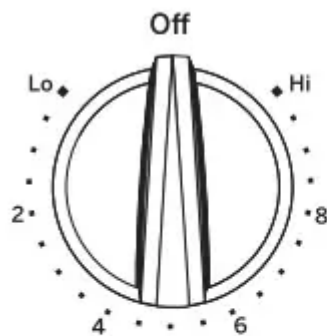

At both **OFF** and **HI** the control clicks into position. You may hear slight clicking sounds during cooking, indicating the control is maintaining your desired setting.

Be sure you turn the control knob to **OFF** when you finish cooking.

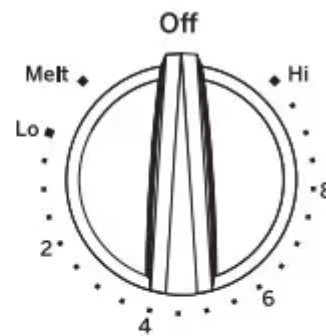

Melt setting (on some models) will melt chocolate or butter.

Dual Surface Units and Control Knobs (on some models)

The surface unit has 2 cooking sizes to select from so you can match the size of the unit to the size of the cookware you are using.

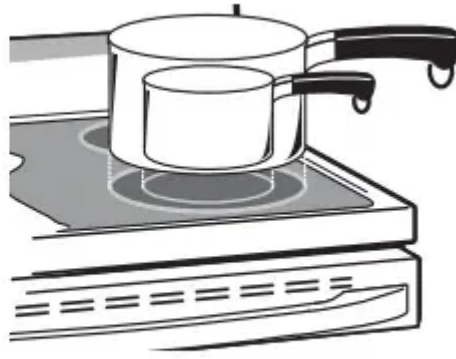
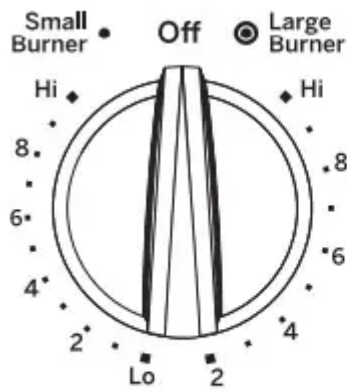

Models with a Dual-Ring surface element only

Using the Warming Zone

FOOD POISON HAZARD: Bacteria may grow in food at temperatures below 140°F.

- Always start with hot food. Do not use warm setting to heat cold food
- Do not use warm setting for more than 2 hours.

The WARMING ZONE, located in the back center of the glass surface, will keep hot, cooked food at serving temperature. Always start with hot food. Do not use to heat cold food. Placing uncooked or cold food on the

WARMING ZONE could result in foodborne illness.

Turn the control knob to the ON position.

For best results, all foods on the WARMING ZONE should be covered with a lid or aluminum foil. When warming pastries or breads, the cover should be vented to allow moisture to escape.

The initial temperature, type and amount of food, type of pan, and the time held will affect the quality of the food.

Always use pot holders or oven mitts when removing food from the WARMING ZONE, since cookware and plates will be hot.

NOTE: The surface warmer will not glow red like the cooking elements.

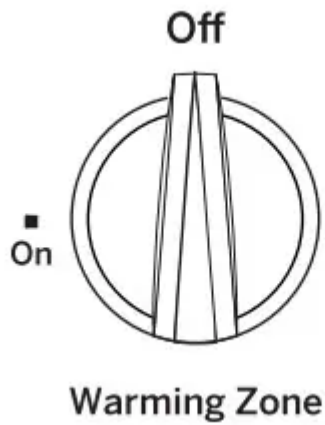

Home Canning Tips

- Be sure the canner is centered over the surface unit.
- Make sure the canner is flat on the bottom.
- To prevent burns from steam or heat, use caution when canning.
- Use recipes and procedures from reputable sources. These are available from manufacturers such as Ball and Kerr and the Department of Agriculture Extension Service.
- Flat-bottomed canners are recommended. Use of water bath canners with rippled bottoms may extend the time required to bring the water to a boil.

Radiant Glass Cooktop



Never cook directly on the glass. Always use cookware.



Always place the pan in the center of the surface unit you are cooking on.



Do not slide cookware across the cooktop because it can scratch the glass—the glass is scratch-resistant, not scratch proof.

The radiant cooktop features heating units beneath a smooth glass surface.

NOTE: A slight odor is normal when a new cooktop is used for the first time. It is caused by the heating of new parts and insulating materials and will disappear in a short time.

NOTE: On models with light-colored glass cooktops, it is normal for the cooking zones to change color when hot or cooling down. This is temporary and will disappear as the glass cools to room temperature.

The surface unit will cycle on and off to maintain your selected control setting.

It is safe to place hot cookware on the glass surface even when the cooktop is cool.

Even after the surface units are turned off, the glass cooktop retains enough heat to continue cooking. To avoid overcooking, remove pans from the surface units when the food is cooked. Avoid placing anything on the surface unit until it has cooled completely

- Water stains (mineral deposits) are removable using the cleaning cream or full-strength white vinegar.
- Use of window cleaner may leave an iridescent film on the cooktop. The cleaning cream will remove this film.
- Don't store heavy items above the cooktop. If they drop onto the cooktop, they can cause damage.
- Do not use the surface as a cutting board.

Oven Controls

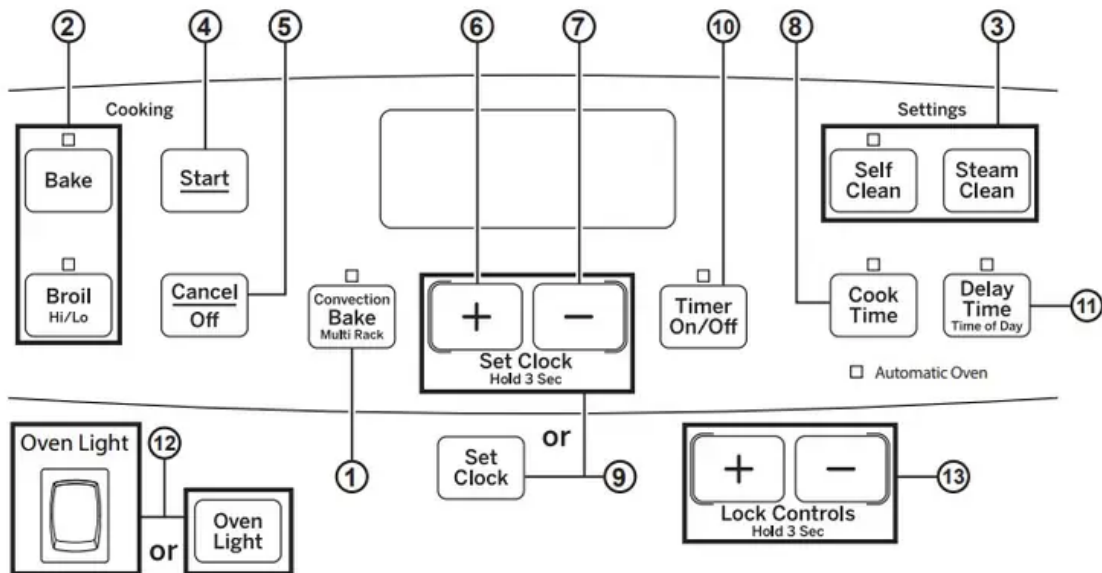

1. Convection Cooking (on some models):

- Convection cooking modes use increased air circulation to improve performance. See the Cooking Modes section for more information.

2. Traditional Cooking Modes:

- Your oven has the following traditional cooking modes: Bake and Broil Hi/Lo. See the Cooking Modes section for more information.

3. Clean (on some models):

- Your oven may have up to two cleaning modes: Self Clean and Steam Clean. See the Cleaning the Oven section for important information about using these modes.

4. Start:

- Must be pressed to start any cooking, cleaning, or timed function.

5. Cancel/Off:

- Cancels ALL oven operations except the clock and timer.

6. + Pad:

- Short taps to this pad will increase the time or temperature by small amounts. Touch and hold the pad to increase the time or temperature by larger amounts.

7. - Pad:

- Short taps to this pad will decrease the time or temperature by small amounts. Touch and hold the pad to decrease the time or temperature by larger amounts.

8. Cook Time:

- Counts down cooking time and turns off the oven when the cooking time is complete. Press the Cook Time pad, use the +/- pads to program a cooking time in hours and minutes, then press Start. This can only be used with Bake and Convection Bake (where available).

9. Clock:

- Sets the oven clock time. Press the Set Clock pad twice or press and hold the +/- pads for 3 seconds and the +/- pads to program the clock. Press Start to save the time.

10. Timer:

- Works as a countdown timer. Press the Timer pad and the +/- pads to program the time in hours and minutes. Press the Start pad. The timer countdown is complete. To turn the timer off press the Timer pad.

11. Delay Time:

- Delays when the oven will turn on. Use this to set a time when you want the oven to start. Press the Delay Time pad and use the +/- pads to program the time of day for the oven to turn on then press Start. Press the desired cooking mode and temperature then press Start. A Cook Time may also be programmed if desired. Follow the directions under Cook Time for setting this feature. This can only be used with Bake, Convection Bake and Self-Clean.

NOTE: When using the Delay Time feature, foods that spoil easily—such as milk, eggs, fish, stuffings, poultry and pork—should not be allowed to sit for more than 1 hour before or after cooking. Room temperature promotes the growth of harmful bacteria. Be sure that the oven light is off because heat from the bulb will speed harmful bacteria growth.

12. Oven Light:

- Turns the oven light on or off.

13. Lock Controls (on some models):

- Locks out the control so that pressing the pads does not activate the controls. Press and hold the +/- pads or the Lock Controls pad, for three seconds to lock or unlock the control. Cancel/Off is always active, even when the control is locked.

Special Features

Adjust the Oven Temperature

- This feature allows the oven baking and convection baking temperature to be adjusted up to 35°F hotter or down to 35°F cooler. Use this feature if you believe your oven temperature is too hot or too cold and wish to change it. This adjustment affects Bake and Convection Bake modes. No other cooking modes are affected.
- Press the Bake pad to enter the temperature adjustment mode. A number between 35 and - 35 will display. Use the +/- pads to set the desired temperature adjustment and use the Bake pad to change between negative and positive. Press the Start pad to save the temperature adjustment.

Clock Display

- This feature can turn off the time of day display. Press the Timer On/Off pad to display the time of day (on) or turn off the time of day display (oFF)

NOTE: For models with a clock pad, the time of day display cannot be turned off in special features. Exit special features. To turn the time of day display off on these models, just press the clock pad once and then the start pad. To have the display turned back on, press the clock pad again and then the start pad.

12-hour auto shut-off and Sabbath

- Options for this feature are "12 SHdn". no SHdn" and "SAD".
- 12-hour auto shut-off turns off the oven after 12 hours of continuous operations.
- Sabbath mode disables all sounds (the control will not beep when a button is pressed), Convection, Broil, Cook Time, Timer, Clock and Delay Time functions. Sabbath mode can only be used with Bake. This feature conforms to the Star-K Jewish Sabbath requirements.

NOTE: The oven light comes on automatically (on some models) when the door is opened and goes off when the door is closed. The bulb may be removed. See the Oven Light Replacement section. On models with a light switch on the control panel. the oven light may be turned on and left on.

- Press the Set Clock pad to view the current setting and then to change the setting.
- For models that do not have a Set Clock pad. press the Cook Time pad to view the current setting and then to change the setting.

- To use Sabbath mode. select "SAb" and press Start. A] will appear in the display and the clock will not display.
- Once in Sabbath mode. at any time you can press Bake to start the oven. Note that when programming a bake in Sabbath mode. the preset starting temperature will automatically be set to 350°F. Press the + or - pads to increase or decrease the temperature in 25°F increments for temperatures between 170°F and 550°F and then press Start.
- No sound will be given when the keys are pressed. At a random time between 30 seconds and 1 minute. Jf. will appear in the display indicating the oven is running.
- If you need to adjust the temperature while baking. press Bake again. Press the + or - pads to increase or decrease the temperature in 25°F from the previous temperature you set to the new baking temperature and then press Start.
- To exit Sabbath mode. make sure that the oven is turned off. To turn the oven off. press Cancel/Off. The oven will immediately turn off and][will change to] indicating that the oven has turned off. Press and hold the Bake and Broil pads for 3 seconds to enter special features then press Delay Time until either "12 Shdn" or "no Shdn" is in the display and press Start.

NOTE: If power outage occurs. the Sabbath mode will not resume when power is restored.

- If you wish to use the Cook Time feature (if available) to bake in the oven and then have the oven automatically turn off. you will need to press the Cook Time pad. enter a cooking time duration. and press Start. Then enter special features to start Sabbath mode as detailed above.

Oven Racks

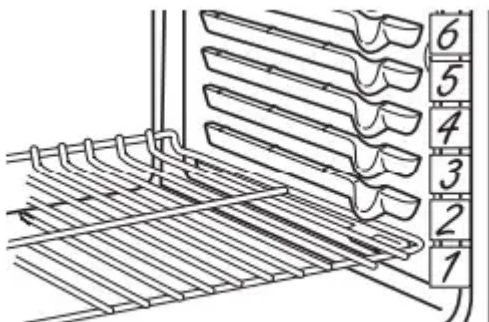

The number of rack positions may vary by model.

- Recommended rack positions for various types of foods are provided in the Cooking Guide. Adjusting rack position is one way to impact cooking results. For example, if you would prefer darker tops on cakes, muffins, or cookies, try moving food one rack position higher. If you find foods are too brown on top try moving them down next time.

- When baking with multiple pans and on multiple racks, ensure there is at least 1½" between pans to allow sufficient space for air to flow.
- To avoid possible burns, place the racks in the desired position before you turn the oven on.

Cooking Modes

Your new oven has a variety of cooking modes to help you get the best results. These modes are described below. Refer to the Cooking Guide section for recommendations for specific foods. Remember, your new oven may perform differently than the oven it is replacing.

Baking Modes

- Select a mode for baking based on the type and quantity of food you are preparing. When preparing baked goods such as cakes, cookies, and pastries always preheat the oven first. Follow recipe recommendations for food placement. If no guidelines are provided, center food in the oven.

Bake

- The bake mode is intended for single rack cooking. This mode uses heat primarily from the lower element but also from the upper element to cook food. To use this mode press the Bake pad, use the +/- pads to set the desired temperature, and then press Start. Preheating is generally recommended when using this mode.

Convection Bake

- The Convection Bake mode is intended for baking on multiple racks at the same time. This mode uses heat from the upper and lower elements, along with air movement from the convection fan to enhance cooking evenness. Baking time might be slightly longer for multiple racks than what would be expected for a single rack. To use this mode press the Convection Bake pad, enter a temperature, and then press Start. Always preheat when using this mode. When baking more delicate foods like cookies and cakes, it is recommended to reduce the input temperature by 25°F for improved cooking performance.

CARE AND CLEANING

Cleaning the Range – Exterior

Control Knobs

- The control knobs may be removed for easier cleaning. Make sure the knobs are in the OFF positions and pull them straight off the stems for cleaning.
- The knobs can be cleaned in a dishwasher or they may also be washed with soap and water. Make sure the inside of the knobs are dry before replacing.

- Replace the knobs, in the OFF position to ensure proper placement.

Control Lockout (on some models)

- If desired, the touch pads may be deactivated before cleaning.
- See Lock Controls in the Oven Controls section in this manual.
- Clean up splatters with a damp cloth.
- You may also use a glass cleaner.
- Reactivate the touch pads after cleaning.

Control Panel

- It's a good idea to wipe the control panel after each use. Clean with mild soap and water or vinegar and water, rinse with clean water and polish dry with a soft cloth.
- Do not use abrasive cleansers. strong liquid cleansers. plastic scouring pads or oven cleaners on the control panel—they will damage the finish

Oven Exterior

- Do not use oven cleaners. abrasive cleansers. strong liquid cleansers. steel wool. plastic scouring pads. or cleaning powders on the interior or exterior of the oven. Clean with a mild soap and water or vinegar and water solution. Rinse with clean water and dry with a soft cloth. When cleaning surfaces. make sure that they are at room temperature and not in direct sunlight.
- If stain on the door vent trim is persistent. use a mild abrasive cleaner and a sponge-scrubber for best results.
- Spillage of marinades. fruit juices. tomato sauces and basting liquids containing acids may cause discoloration and should be wiped up immediately. Let hot surfaces cool. then clean and rinse.

Painted Surfaces

- Painted surfaces include the sides of the range and the door, top of control panel and the drawer front. Clean these with soap and water or a vinegar and water solution.
- Do not use commercial oven cleaners. cleaning powders. steel wool or harsh abrasives on any painted surface.

Cleaning the Range – Interior

- The interior of your new oven can be cleaned manually or by using Steam Clean or Self Clean modes.
- Spillage of marinades, fruit juices, tomato sauces and basting liquids containing acids may cause discoloration and should be wiped up immediately. Let hot surfaces cool, then clean and rinse.

Manual Cleaning

- Do not use oven cleaners, abrasive cleaners, strong liquid cleansers, steel wool, scouring pads, or cleaning powders on the interior of the oven. Clean with a mild soap and water or vinegar and water solution. Rinse with clean water and dry with a soft cloth. When cleaning surfaces, make sure that they are at room temperature.

Porcelain Oven Interior (on models that do not have a self-clean feature)

With proper care, the porcelain enamel finish on the inside of the oven—top, bottom, sides, back and inside of the door—will stay new-looking for years.

Let the oven cool before cleaning. We recommend that you wear rubber gloves when cleaning the oven.

Soap and water will normally do the job. Heavy spattering or spillovers may require cleaning with a mild abrasive cleaner. Soap-filed scouring pads may also be used.

Do not allow food spills with a high sugar or acid content (such as tomatoes, sauerkraut, fruit juices or pie filling) to remain on the surface. They may cause a dull spot even after cleaning.

Household ammonia may make the cleaning job easier. Place 1/2 cup in a shallow glass or pottery container in a cold oven overnight. The ammonia fumes will help loosen the burned-on grease and food.

If necessary, you may use an oven cleaner. Follow the package directions.

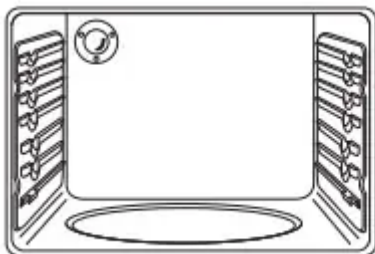

- Do not spray oven cleaner on the electrical controls and switches because it could cause a short circuit and result in sparking or fire.
- Do not allow a film from the cleaner to build up on the temperature sensor—it could cause the oven to heat improperly. (The sensor is located at the top of the oven.) Carefully wipe the sensor clean after each oven cleaning, being careful not to move the sensor as a change in its position could affect how the oven bakes.
- Do not spray any oven cleaner on the oven door, handles or any exterior surface of the oven, cabinets or painted surfaces. The cleaner can damage these surfaces.

Steam Clean Mode (on some models)

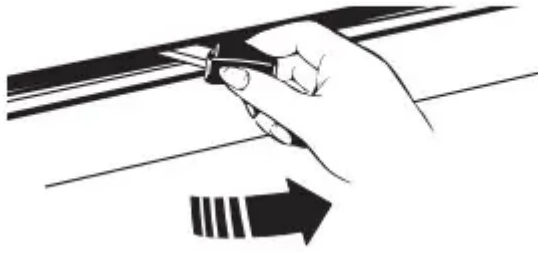

- Steam clean is intended to clean small spills using water and a lower cleaning temperature than Self-Clean.
- To use the Steam Clean feature, wipe grease and soils from the oven. Pour one cup of water into the bottom of the oven. Close the door. Press the Steam Clean pad and then press Start. Latch the door. You can not open the door during the 30 minute steam clean as this will decrease the steam clean performance. At the end of the steam clean cycle, wipe out any excess water and any remaining soil.

Racks

- All racks can be washed with warm, soapy water. Enameled (not shiny) racks can be left in the cavity during self clean.
- Racks may be more difficult to slide, especially after a self-clean. Put some vegetable oil on a soft cloth or paper towel and rub onto the left and right edges.

TROUBLESHOOTING TIPS

Surface units will not maintain a rolling boil or cooking is not fast enough

- Improper cookware being used.
 - Use pans which are flat and match the diameter of the surface unit selected.
- In some areas, the power (voltage) may be low.
 - Cover pan with a lid until desired heat is obtained.

Surface units do not work properly

- A fuse in your home may be blown or the circuit breaker tripped.
 - Replace the fuse or reset the circuit breaker.
- Cooktop controls improperly set.
 - Check to see the correct control is set for the surface unit you are using.

Surface unit stops glowing when turned to a lower setting

- The unit is still on and hot.
 - This is normal.

Scratches (may appear as cracks) on cooktop glass surface

- Incorrect cleaning methods being used.
 - Scratches are not removable. Tiny scratches will become less visible in time as a result of cleaning.
- Cookware with rough bottoms being used or coarse particles (salt or sand) were between the cookware and the surface of the cooktop. Cookware has been slid across the cooktop surface.
 - To avoid scratches, use the recommended cleaning procedures. Make sure bottoms of cookware are clean before use, and use cookware with smooth bottoms.

Areas of discoloration on the cooktop

- Food spillovers not cleaned before next use.
 - See the Cleaning the glass cooktop section.
- Hot surface on a model with a lightcolored cooktop.
 - This is normal. The surface may appear discolored when it is hot. This is temporary and will disappear as the glass cools.

Plastic melted to the surface

- Hot cooktop came into contact with plastic placed on the hot cooktop.
 - See the Glass surface—potential for permanent damage section in the Cleaning the glass cooktop section

Pitting (or indentation) of the cooktop

- Hot sugar mixture spilled on the cooktop.
 - Call a qualified technician for replacement

Frequent cycling off and on of surface units

- Improper cookware being used.
 - Use only flat cookware to minimize cycling

My new oven doesn't cook like my old one. Is something wrong with the temperature settings?

- Your new oven has a different cooking system from your old oven and therefore may cook differently than your old oven.
 - For the first few uses, follow your recipe times and temperatures carefully. If you still think your new oven is too hot or too cold, you can adjust the temperature yourself to meet your specific cooking preference. NOTE: This

adjustment affects Bake, and Convection Bake temperatures; it will not affect Convection Roast, Broil or Clean

Food does not bake properly

- Oven controls improperly set.
 - See the Cooking Modes section.
- Rack position is incorrect or rack is not level.
 - See the Cooking Modes section and Cooking Guide.
- Incorrect cookware or cookware of improper size being used.
 - See the Cookware section
- Oven temperature needs adjustment.
 - See the Special Features section.
- Ingredient substitution
 - Substituting ingredients can change the recipe outcome.

Food does not broil properly

- Oven controls improperly set.
 - Make sure you select the appropriate broil mode.
- Improper rack position being used.
 - See Cooking Guide for rack location suggestions.
- Food being cooked in a hot pan.
 - Make sure cookware is cool.
- Cookware not suited for broiling.
 - Use a pan specifically designed for broiling.
- Aluminum foil used on the broiling pan and grid has not been fitted properly and slit as recommended.
 - If using aluminum foil conform to pan slits.
- In some areas the power (voltage) may be low.
 - Preheat the broil element for 10 minutes.

Oven temperature too hot or too cold

- Oven temperature needs adjustment.
 - See the Special Features section.

Oven does not work or appears not to work

- A fuse in your home may be blown or the circuit breaker tripped.
 - Replace the fuse or reset the circuit breaker.
- Oven controls improperly set.
 - See the using the oven section
- Oven is in Sabbath Mode.
 - Verify, that the oven is not in Sabbath Mode. See the Special Features section.

“Crackling” or “popping” sound

- This is the sound of the metal heating and cooling during both the cooking and cleaning functions.
 - This is normal.

Why is my range making a "clicking" noise when using my oven?

- Your range cycles the heating elements by turning relays on and off to maintain the oven temperature.
 - This is normal.

Clock and timer do not work

- A fuse in your home may be blown or the circuit breaker tripped.
 - Replace the fuse or reset the circuit breaker
- Plug on range is not completely inserted in the electrical outlet.
 - Make sure electrical plug is plugged into a live, properly grounded outlet.
- Oven controls improperly set.
 - See the using the kitchen timer section

Storage drawer won't close

- Power cord may be obstructing drawer in the lower back of the range.
 - Reposition the drawer and power cord. See the Storage Drawer Removal instructions in the Care and cleaning of the range section
- Rear drawer support is on top of the guide rail.
 - Reposition the drawer. See the Storage Drawer Removal instructions in the Care and cleaning of the range section.

Oven door is crooked

- The door is out of position
 - Because the oven door is removable, it sometimes gets out of position during installation. To straighten the door, re-install the door.

Oven light does not work

- Light bulb is loose or defective.
 - Tighten or replace bulb.
- Pad operating light is broken.
 - Call for service.

Oven will not self-clean

- The temperature is too high to set a self-clean operation.
 - Allow the oven to cool and reset the controls.
- Oven controls improperly set.
 - See the Cleaning the Oven section.

Excessive smoking during clean cycle

- Excessive soil or grease.
 - Press the Cancel/Off pad. Open the windows to rid the room of smoke. Wait until the LOCKED light goes off. Wipe up the excess soil and reset the clean cycle.

Excessive smoking during broiling

- Food too close to burner element.
 - Lower the rack position of the food.

Oven door will not open after a clean cycle

- Oven too hot.
 - Allow the oven to cool below locking temperature.

Oven not clean after a clean cycle

- Oven controls improperly set.
 - See the Cleaning the Oven section
- Oven was heavily soiled.
 - Clean up heavy spillovers before starting the clean cycle. Heavily soiled ovens may need to self-clean again or for a longer period of time.

"LOCK DOOR" flashes in the display

- The self-clean cycle has been selected but the door is not closed.
 - Close the oven door. Latch the door.

DOOR LOCK light is on when you want to cook

- The oven door is locked because the temperature inside the oven has not dropped below the locking temperature.
 - Press the Cancel/Off pad. Allow the oven to cool.

"F— and a number or letter" flash in the display

- You have a function error code.
 - Press the Cancel/Off pad. Allow the oven to cool for one hour. Put the oven back into operation.
- If the function code repeats.
 - Disconnect all power to the oven for at least 30 seconds and then reconnect power. If the function error code repeats, call for service.

Display goes blank

- A fuse in your home may be blown or the circuit breaker tripped.
 - Replace the fuse or reset the circuit breaker.
- The clock is turned off.
 - See the Special features section.
- Oven is in Sabbath Mode.
 - Verify that the oven is not in Sabbath Mode. See the Special Features section.

Power outage, clock flashes

- Power outage or surge
 - Reset the clock. If the oven was in use, you must reset it by pressing the Cancel/Off pad, setting the clock and resetting any cooking function.

"Burning" or "oily" odor emitting from the vent

- This is normal in a new oven and will disappear in time.
 - To speed the process, set a self-clean cycle for a minimum of 3 hours. See the Cleaning the Oven section.

Strong odor

- An odor from the insulation around the inside of the oven is normal for the first few times the oven is used.
 - This is temporary and will go away after several uses or a self-clean cycle.

Fan noise (on some models)

- A convection fan may automatically turn on and off.
 - This is normal. The fan is designed to operate intermittently to maximize cooking evenness. The convection fan will operate during preheat of the bake cycle. The fan will turn off after the oven is heated to the set temperature. This is normal.

My oven door glass appears to be "tinted" or have a "rainbow" color. Is this defective?

- No. The inner oven glass is coated with a heat barrier to reflect the heat back into the oven to prevent heat loss and keep the outer door cool while baking.
 - This is normal. Under certain light or angles, you may see this tint or rainbow color.

Warning

This content is compiled from multiple sources and is provided for reference purposes only. It may not be complete or fully applicable to all situations. If you are unable to resolve your issue, please contact the product manufacturer or an authorized service provider for official support.