

## Setting up your microwave oven

Be sure to follow these instructions closely so that your new microwave oven works properly.

### CHECKING THE PARTS

Carefully unpack your microwave oven, and make sure you've received all the parts shown below. If your microwave oven was damaged during shipping, or if you do not have all the parts, contact Samsung Customer Service. (Refer to the "Warranty and service information")

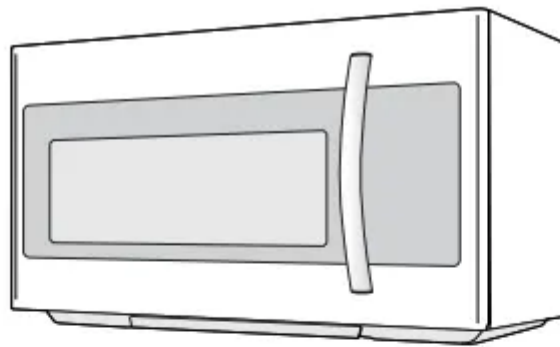

Microwave oven (ME20H705MS<sup>+</sup>)



\* Shelf



\* Glass Tray



\* Roller Guide Ring



\* Grease filter (Installed)



\* Charcoal filter



\* Exhaust adaptor



\* Hardware kit (Screws & Brackets)

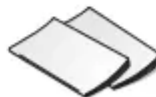

Manuals (User & Installation)

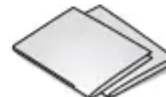

Templates (Top & Wall)

### SETTING UP YOUR MICROWAVE OVEN

1. Open the door by pulling the handle on the right side of the door.

2.



Wipe the inside of the oven with a damp cloth.

3. Install the pre-assembled ring into the indentation at the center of the microwave oven.



4. Place the glass tray securely in the center of the preassembled roller ring.



## FEATURES

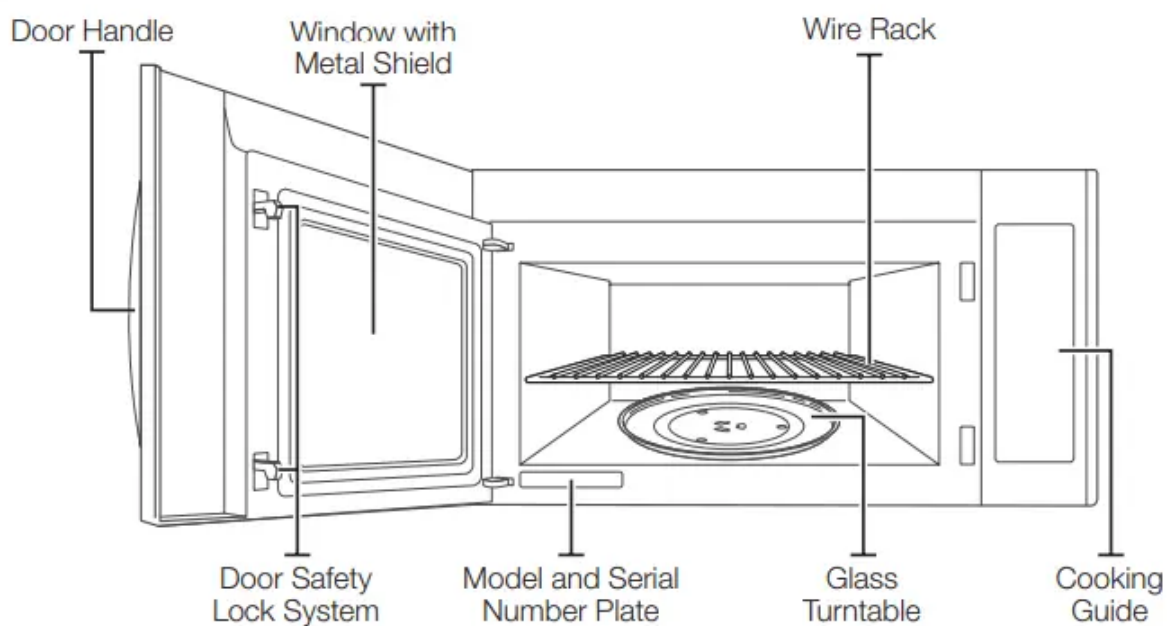

## THE CONTROL PANEL

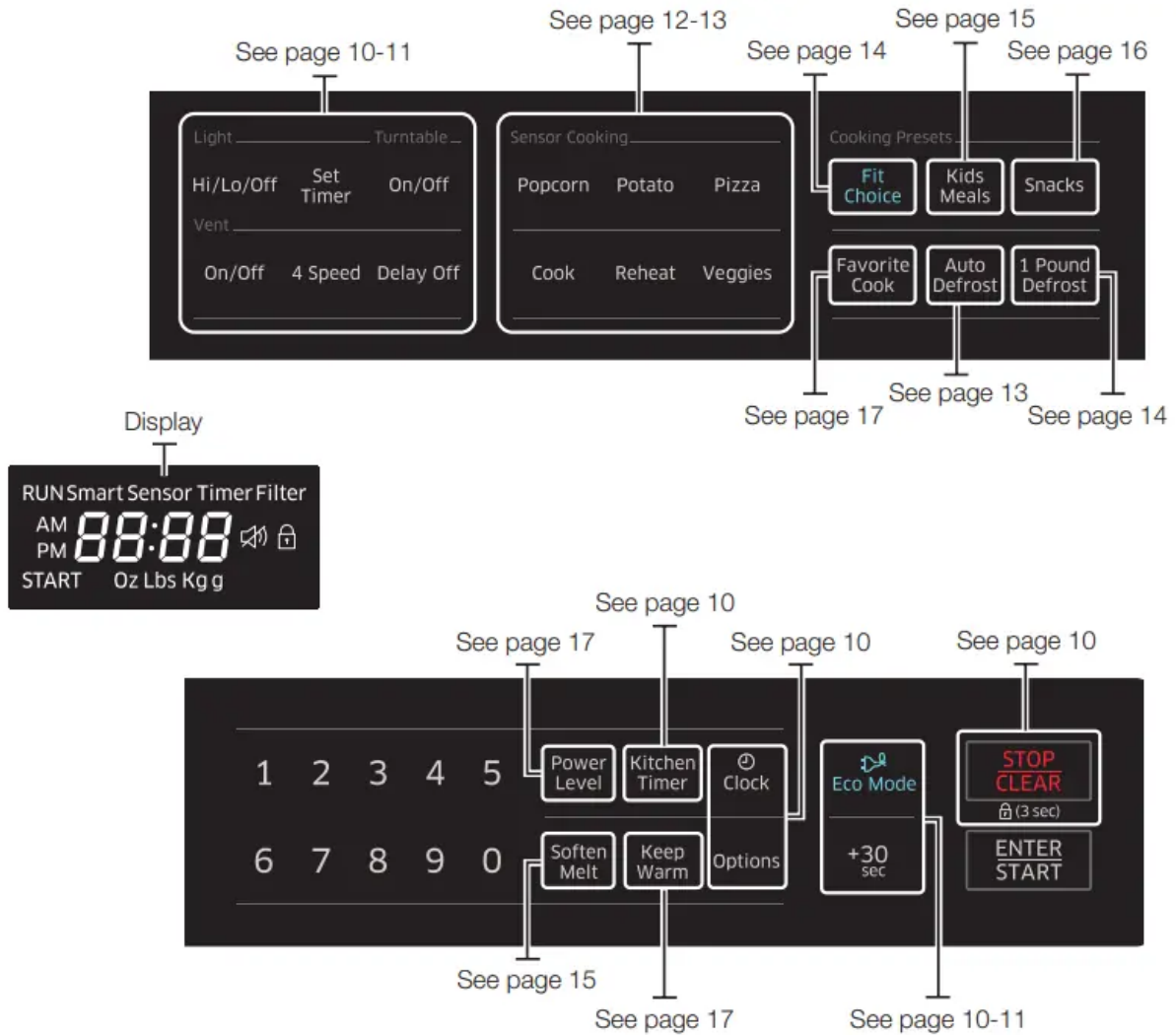

## USING YOUR MICROWAVE OVEN

### SETTING THE TIME

Your microwave oven is equipped with a built-in clock. Set the clock when first installing your microwave oven and after a power failure. The time is displayed whenever the microwave oven is not being used.

1. Press the Clock button.
2. Use the number buttons to enter the current time. You need to press at least three numbers to set the clock. For example, if the current time is 5:00, press 5, 0, 0. The display will show: 500.
3. Press the Clock button.
4. Use the Clock button to select AM / PM.
5. Press the ENTER/START button.

6. A colon appears indicating that the time is set.

To check the time while cooking, press the Clock button.

## CHILD LOCK

- The Child Lock function allows you to lock the buttons so that the microwave oven cannot be operated accidentally. The oven can be locked at any time.
- Activating/Deactivating: If you want to activate or deactivate the child lock function, press the STOP/CLEAR button for 3 seconds. The display will show ON or OFF when the oven is locked or unlocked, and then re-displays the time.

## OPTIONS

You can customize your new microwave oven to suit your preferences.

To customize:

1. Press the Options button.
2. Press the number button that corresponds to the function you want to customize.
3. Press the number that corresponds to the option you want to set.
4. Press the ENTER/START button to set the option. The functions, options, and corresponding number buttons are listed in the table below

No.	Function	Options
OP-1	Weight mode selected	1 Lbs. 2 Kg. (Gram)
OP-2	Clock display control	1 12HR 2 24HR
OP-3	Sound on/off control	1 Sound ON 2 Sound OFF
OP-4	Remind end signal	1 ON 2 OFF
OP-5	Daylight Saving time	1 ON 2 OFF
OP-6	Demo mode	1 ON 2 OFF
OP-7	Filter Reminder	1 ON 2 OFF

### Filter Reminder

- The filter should be cleaned or replaced once every four months. When it is time to clean or replace the filter, the microwave displays the "Filter" message to remind you to clean or replace the filter. To remove the message, touch the number 0 when the microwave is in standby mode, or access Options.

## KITCHEN TIMER BUTTON

Use the Kitchen Timer for timing up to 99 minutes, 99 seconds.

1. Press the Kitchen Timer button.
2. Use the number buttons to set the length of time you want the timer to run.
3. Press the ENTER/START button
4. The display counts down and beeps when the time has elapsed.
5. To cancel the timer setting: Press the STOP/ CLEAR button once.

## ADD 30 SEC BUTTON

This simplified control saves you time, letting you quickly start cooking at 100 % power.

1. Press the Add 30 sec button for each 30 seconds you want food to cook. For example, press it twice to cook for one minute, and then press the ENTER/START button to start cooking.
2. Add 30 sec to a cooking program already in progress by pressing the Add 30 sec button for every additional 30 seconds you want to add.

## VENT BUTTONS (4 SPEED & ON/OFF)

The vent removes steam and other vapors from the cooking surface. You can manually select the vent setting.

1. Press the Vent 4 Speed button to set the speed level.
2. Press the Vent On/Off button to turn the vent on.
3. Press the Vent On/Off button again to turn the vent off.

The exhaust fan's speed will reduce when the oven's cooking function is activated.

## VENT DELAY OFF BUTTON

Press the Delay Off button once to turn the fan off after a certain number of minutes. The number of minutes depends on how many times you press the button.

Press (times)	1	2	3	4	5
Delay off (min)	1	3	5	10	30

## LIGHT HI/LO/OFF BUTTON

The Light button allows you to select a light setting for your microwave.

Press (times)	1	2	3
Light	High	Low	Off

## SET TIMER BUTTON

You can set the microwave so the light turns on and off automatically at a preset time. The light comes on at the same time every day until reset.

1. Press the Set Timer button.
2. Use the number buttons to set the light on time.
3. Press the Clock button to select AM or PM.
4. Press the ENTER/START button.
5. Use the number buttons to set the light off time.
6. Press the Clock button to select AM or PM.
7. Press the ENTER/START button.

## TURNTABLE ON/OFF BUTTON

- For best cooking results, leave the turntable on. However, for large dishes it can be turned off. Press the Turntable On/Off button to turn the turntable on or off.
- CAUTION: The turntable may become too hot to touch. Use pot holders to touch the turntable during and after cooking.

## METAL SHELF

Use the metal shelf to cook more than one item at the same time.

- Do not use a microwave browning dish on the shelf. The shelf could overheat.
- Do not use the oven with the shelf on the microwave floor. This could damage the microwave.
- Use pot holders when handling the shelf as it may be hot.
- Do not use the metal shelf when cooking popcorn.

Food cooks best on the turntable.



**For best results**

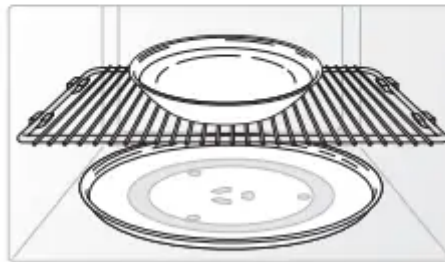

**Uneven results**

The shelf gives you the option to reheat more than one dish at the same time.



## Reheating food

To reheat food on 2 levels or to reheat food on the lower level:

- Multiply the reheating time by 1½.
- Switch places halfway through the reheating process.

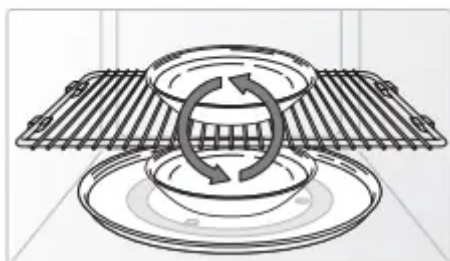
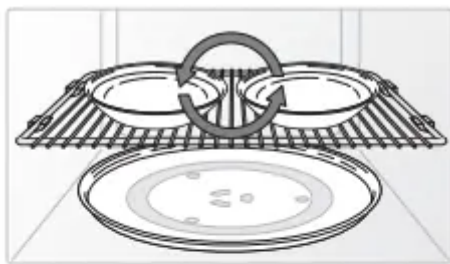

## ECO MODE

- Eco Mode reduces standby power usage. When you press the Eco Mode button once, the display will go out and the microwave shifts to the mode which minimizes power usage.
- To cancel the Eco Mode, press the Eco Mode button once again, or press any other button.

## SENSOR COOKING BUTTONS

- The Sensor Cooking buttons let you cook favorite foods using preset power levels and times at the touch of a button. If the food is not thoroughly cooked or reheated when you use the auto cook feature, complete the cooking process by selecting a power level and cooking the food for an additional amount of time.
- CAUTION: Do not use the Sensor Cooking buttons continuously. The oven must cool for 5 minutes between uses or the food will overcook.

### Sensor cooking utensils & covers

- To obtain good cooking results using these functions, follow the directions for selecting appropriate containers and covers in the Cookware Guide section .
- CAUTION: Always use microwave-safe containers and cover with a lid or plastic wrap. When using plastic wrap, turn back one corner to allow steam to escape.
- CAUTION: Fill containers at least half full.
- Foods that require stirring or rotating should be stirred or turned at the end of the Sensor Cook cycle, when the time has started to count down on the display.
- Do not use the Auto Sensor cooking feature continuously. Wait 5 minutes before selecting another sensor cooking operation.

- For the best cooking results, do not use the Auto Sensor when the ambient room temperature is too high or too low.

### Sensor cooking table

Food		Amount	Procedure
Popcorn		3.0 - 3.5 oz. 1 package	Heat only one microwave popcorn bag at a time. Be careful when removing the heated bag from the oven and opening it. Let the oven cool for at least 5 minutes before using it again.
Cook	Beverage (Co-1)	8 oz.	Use a measuring cup or mug and do not cover. Place the beverage in the oven. After heating, stir well. Let the oven cool for at least 5 minutes before using it again.
	Chicken breast (Co-2)	8 to 16 oz.	Place the chicken breasts in a microwave safe plate and cover with plastic wrap. Cook to an internal temperature of 170 °F. Let stand for 5 minutes.
	Frozen breakfast (Co-3)	4 to 8 oz.	Use this button for frozen sandwiches, breakfast entrees, pancakes, waffles, etc. Follow the package instructions for covering and standing. Let the oven cool for at least 5 minutes before using it again.
	Frozen dinner (Co-4)	8 to 14 oz.	Remove the food from its wrapping and follow the instructions on the box for covering and letting stand. Let the oven cool for at least 5 minutes before using it again.
Veggies	Fresh vegetables (Fr-1)	1 to 4 cups	Place the fresh vegetables in a microwave-safe ceramic, glass, or plastic dish and add 2-4 tbs. water. Cover with a lid or vented plastic wrap while cooking and stir before letting stand. Let the oven cool for at least 5 minutes before using it again.
	Frozen vegetables (Fr-2)	1 to 4 servings	Place the frozen vegetables in a microwave-safe ceramic, glass, or plastic dish and add 2-4 tbs. water. Cover with a lid or vented plastic wrap to cook. stir before letting stand for 3-5 minutes. Let the oven cool for at least 5 minutes before using it again.
Potato		1 to 6 potatoes.	Pierce each potato several times with a fork. Place on the turntable in a spoke-like fashion. After cooking, let the potatoes stand for 3-5 minutes. Let the oven cool for at least 5 minutes before using it again.
Pizza		1 to 3 slices	Place 1-3 pizza slices on a microwave-safe plate with the wide ends of the slices towards the outside edge of the plate. Do not let the slices overlap. Do not cover. Let the oven cool for at least 5 minutes before using it again.

## REHEAT BUTTON

- Heating leftovers and precooked foods is easy with your new microwave. By actually sensing the humidity that escapes as the food is heated, the oven's heating time is automatically adjusted depending on the type and amount of precooked food.
- All food must already be precooked. Plates of food and casseroles should be stored at refrigerator temperature. Press the Reheat button and ENTER/START button to begin reheating your precooked food. If you want to check the current time while reheating, press the Clock button.

**Reheating table:** Follow the instructions below when reheating different types of food.

#### 1. Food: Dinner plate (rh-2)

- Amount: 1 serving (1 plate)
  - Procedure: Use only precooked, refrigerated foods. Cover the plate with vented plastic wrap or waxed paper tucked under the plate. If the food is not as hot as you would like after using the Sensor Reheat function, continue heating using additional time and power. Contents: 3-4 oz. meat, poultry, or fish (up to

to 6 oz. with bone) ½ cup starch (potatoes, pasta, rice, etc.) ½ cup vegetables (about 3 - 4 oz.)

## 2. Food: Casserole (rh-1); Pasta (rh-3)

- Amount: 1 to 4 servings
  - Procedure: Cover the plate with a lid or vented plastic wrap. If the food is not as hot as you would like after using the “Sensor Reheat” function, continue heating using additional time and power. Stir the food once before serving.
- Contents: Casserole, refrigerated foods. Pasta: canned spaghetti and ravioli

## **AUTO DEFROST BUTTON**

To thaw frozen foods, enter the weight of the food, and the microwave automatically sets the defrosting time, power level, and standing time. Press ENTER/START button to start defrosting.

1. Press the Auto Defrost button.
2. Press the number buttons to directly enter the weight of the food.
3. Press the ENTER/START button.
4. The oven will beep twice during the defrosting process. Open the oven door, and turn the food over.

Auto defrosting table: Follow the instructions below when defrosting different types of food.

### 1. Roast Beef, Pork

- Amount: 2.5 - 6.0 lbs.
- Procedure: Start with the food placed fat side down. After each stage, turn the food over and shield any warm portions with narrow strips of aluminum foil. Let stand, covered for 10- 20 minutes.

### 2. Steaks, Chops, Fish

- Amount: 0.5 - 3.0 lbs.
- Procedure: After each stage, rearrange the food. If there are any warm or thawed portions of food, shield them with narrow, flat pieces of aluminum foil. Remove any pieces of food that are nearly defrosted. Let stand, covered for 5-10 minutes.

### 3. Ground Meat

- Amount: 0.5 - 3.0 lbs.
- Procedure: After each stage, remove any pieces of food that are nearly defrosted. Let stand, covered with foil for 5-10 minutes.

### 4. Whole Chicken

- Amount: 2.5 - 6.0 lbs

- Procedure: Remove giblets before freezing poultry. Start defrosting with the breast side down. After the first stage, turn the chicken over and shield any warm portions with narrow strips of aluminum foil. After the second stage, again shield any warm portions with narrow strips of aluminum foil. Let stand, covered for 30-60 minutes in the refrigerator

## 5. Chicken Pieces

- Amount: 0.5 - 3.0 lbs.
- Procedure: After each stage, rearrange or remove any pieces of food that are nearly defrosted. Let stand for 10-20 minutes.

Check the food when you hear the oven signal. After the final stage, small sections may still be icy. Let the food stand to continue the thawing process. The food is not defrosted until all ice crystals have melted. Shielding the edges of roasts and pieces of steak using small pieces of foil prevents the edges from being cooked before the center of the food has defrosted. Use narrow, flat, smooth strips of aluminum foil to cover edges and thinner sections of the food.

## **FIT CHOICE BUTTON**

1. Press the Fit Choice button. Press the button repeatedly to cycle through the available items. (Refer to the Fit Choice table below for a list of the items.)
2. Press the 1, 2, 3, or 4 button to select the amount.
3. Press the ENTER/START button to begin cooking

## **Fit Choice table**

Menu / item		No. / Amount		Remarks
FC-1	Spinach	1	1 serving	Wash and clean the spinach. Place the spinach in a microwave safe bowl. Add 1-4 tablespoons of water (1 Tbsp per serving). Cover during cooking and stir afterwards.
		2	2 servings	
		3	3 servings	
		4	4 servings	
FC-2	Squash	1	1 - 2 lbs.	Slice the squash in half and remove the seeds. Place the squash cut side down in a microwave safe dish and cover with the plastic wrap. If needed, add a ¼ cup of water.
		2	2 - 3 lbs.	
FC-3	Brown rice	1	1 serving	Place 0.5 cup brown rice + 1 cup water for 2 servings or 1 cup brown rice + 2 cups water for 4 servings in a microwave safe bowl. Stir well before and fluff with a fork afterwards. Let stand 5 minutes before serving.
		2	2 servings	
FC-4	Oatmeal	1	1 package	Follow the package directions for the recommended amount of water needed. Stir well before and afterwards.
		2	2 packages	
FC-5	Quinoa	1	1 serving	Follow the package directions for the recommended amount of water needed. When the microwave beeps, stir well, and then restart the microwave.
		2	2 servings	
FC-6	Bone in chicken pieces	1	2 servings	Brush the chicken pieces with oil and seasonings. Arrange chicken pieces in dish with meatiest portions toward the outside edge of dish, and then cover with wax paper. Place the dish on the center of the turntable.
		2	4 servings	
FC-7	Fresh fish fillet	1	1 serving	Put the fillets (cod, pollack, etc.) in a dish, and then cover with plastic wrap. Place the dish on the center of the turntable.
		2	2 servings	
FC-8	Fresh salmon fillet	1	1 serving	Put the salmon fillets in a dish, and then cover with plastic wrap. Place the dish on the center of the turntable.
		2	2 servings	
FC-9	Fresh prawns	1	2 servings	Put the prawns in a dish, and then cover with plastic wrap. Place the dish on the center of the turntable.
		2	4 servings	

## 1 POUND DEFROST BUTTON

To thaw 1 lb. of frozen food, press this button, and the microwave automatically sets the defrosting time, power level and standing time.

1. Press the 1 Pound Defrost button. The display shows: 1.0 Lbs
2. Press the ENTER/START button to start defrosting.
3. The oven will beep during the defrosting process. Open the oven door, turn the food over, and the press the ENTER/START button.
4. If you do not turn the food over, the oven will pause until you press the ENTER/START button.

## SOFTEN/MELT BUTTON

1. Press the Soften/Melt button. Press the button repeatedly to cycle through the available items. (Refer to the Soften/Melt table below for a list of the items.)
2. Press the number 1 or 2 button to select the amount. You can cook only 1 serving using the Melt Chocolate, Soften Butter, and Soften Cream Cheese options. (Refer to the Soften/Melt table for the serving size.)

3. Press the ENTER/START button to begin cooking.



#### Soften / Melt table

Menu / item		No. / Amount		Remarks
St-1	Melt butter	1	1 stick (serving)	Remove the wrapping and cut the butter in half vertically. Place the butter in a dish and cover with wax paper. Stir well after finishing and let stand for 1-2 minutes.
		2	2 sticks (serving)	
St-2	Melt chocolate	1	1 cup chips or 1 square	Place the chocolate chips or squares in a microwave-safe container. When the oven beeps, stir the chocolate and restart the oven. Stir and let stand for 1 minute.
St-3	Soften butter	1	1 stick (1/4 lbs.)	Remove wrapping and cut butter in half vertically. Place butter in dish, cover with wax paper.
St-4	Soften cream cheese	1	1 package (8-oz)	Unwrap the cream cheese and place on a microwave-safe container. Cut in half vertically. Let stand for 2 minutes.

### KIDS MEALS BUTTON

1. Press the Kids Meals button. Press the button repeatedly to cycle through the available items. (Refer to the Kids meals table below for a list of the items.)
2. Press the number 1 or 2 button to select the amount. (Refer to the Kids meals table for the serving size.)
3. Press the ENTER/START button to begin cooking.

#### Kids meals table

Menu / item		No. / Amount		Remarks
CH-1	Chicken nuggets (frozen)	1	1 serving	Place a paper towel on a plate and arrange the nuggets in a spoke-like fashion on the paper towel. Do not cover. Let stand for 1 minute after heating.  Refer to the package directions for the serving size and the amount of food.
		2	2 servings	
CH-2	French fries (frozen)	1	1 serving	Place two paper towels on a microwave-safe plate and arrange the French fries on the towels without letting them overlap. Blot the fries with additional paper towels after removing from the oven. Let stand for 1 minute.  Refer to the directions on the packaging for the serving size and the amount of food.
		2	2 servings	
CH-3	Frozen sandwiches (in crisping sleeve) 9-oz package size	1	1 sandwich (1 ea)	Place the frozen sandwich in a susceptor "crisping sleeve" (which is in the package) and place on a microwave-safe plate. Remove from the "crisping sleeve". Let stand for 2 minutes after heating.
		2	2 sandwiches (2 ea)	
CH-4	Hot dogs	1	2 hot dogs (2 ea)	Pierce the hot dogs and place them on a plate. When the oven beeps, add the buns and restart the oven. Let stand for 1 minute after heating.  For the best texture, the buns should be added to the hot dogs when the oven beeps.
		2	4 hot dogs (4 ea)	

### SNACKS BUTTON

1. Press the Snacks button. Press the button repeatedly to cycle through the available items. (Refer to the Snacks table below for a list of the items.)

2. Press the number 1 or 2 button to select the serving size. You can cook only 1 serving for Nachos. (Refer to the Snacks table for the serving size.)
3. Press the ENTER/START button to begin cooking.

#### Snacks table

Menu / item		No. / Amount		Remarks
Sn-1	Cheese sticks (frozen)	1	5 - 6 pcs (1 Sr)	Place the cheese sticks on a plate in a spoke-like fashion. Do not cover. Let stand for 1 to 2 minutes after heating.
		2	7 - 10 pcs (2 Sr)	
Sn-2	Chicken wings	1	5 - 6 oz. (1 Sr)	Use precooked, refrigerated chicken wings. Place the chicken wings around the plate in a spoke-like fashion and cover with wax paper. Let stand for 1 to 2 minutes.
		2	7 - 8 oz. (2 Sr)	
Sn-3	Nachos	1	1 serving	Place the nachos on a plate without letting them overlap. Sprinkle cheese evenly over them. <b>Contents:</b> 2 cups tortilla chips 1/3 cup grated cheese
Sn-4	Potato skins	1	1 cooked potato (1 ea)	Cut the cooked potato into 4 even wedges. Scoop or cut out the potato flesh, leaving about a ¼ in. of skin. Place the skins in a spoke-like fashion around the plate. Sprinkle with bacon, onions and cheese. Do not cover. Let stand 1 to 2 minutes.
		2	2 cooked potatoes (2 ea)	

## MICROWAVE COOKING TIMES & POWER LEVELS

Your oven allows you to set two different cooking stages, each with its own time length and power level. The power level lets you control the heating intensity from Warm (1) to High (10)

### One-stage cooking

For simple, one-stage cooking, you only need to set the cooking time. The power level is automatically set to High. If you want to set the power level to any other level, use the Power Level button.

1. Use the number buttons to set a cooking time. You can enter a time from one second to 99 minutes and 99 seconds. To select a time greater than one minute, enter the seconds too. (For example, to set a cooking time of 20 minutes, enter 2, 0, 0, 0.)
2. If you want to set the power level to a level other than High, press the Power Level button, and then use the number buttons to enter the power level.
3. Press the ENTER/START button to begin cooking. If you want to change the power level, press the STOP/ CLEAR button before you press the ENTER/START button, and then enter all the instructions again.

Some recipes require different cooking stages at different temperatures. Your microwave allows you to set multiple cooking stages.

## Multi-stage cooking

1. Follow steps 1 and 2 from the “One-stage cooking” section. When selecting more than one cooking stage, you must press the Power Level button before you can enter the second cooking stage. Press the Power Level button twice to set the power level to High for a cooking stage.
2. Use the number buttons to set a second cooking time.
3. Press the Power Level button, and then use the number buttons to set the power level for the second cooking stage.
4. Press the ENTER/START button to begin cooking

## KEEP WARM

You can keep cooked food warm in your microwave oven for up to 99 minutes 99 seconds.

1. Press the Keep Warm button.
2. Enter the warming time.
3. Press the ENTER/START button.

Keep Warm operates for up to 99 minutes 99 seconds.

Food that is cooked covered should also be covered during Keep Warm.

Pastry items (pies, turnovers, etc.) should be uncovered during Keep Warm.

Complete meals kept warm on a dinner plate can be covered during Keep Warm.

Below are the amounts of food we recommend you apply the Warm and Hold function to by Food Type.

- Liquid: 1 - 2 cups
- Dry: 5 - 10 oz.

## FAVORITE COOK BUTTON

The Favorite Cook button lets you store a customized set of cooking instructions, and recall this setting later from the microwave’s memory to begin cooking quickly.

Only one set of instructions can be stored at a time.

1. Press the Favorite Cook button.
2. Use the number buttons to enter the cooking time. The display will show the set time.
3. Press the Power Level button and use the number buttons to enter the power level. The display will show the selected power level. You can set the power level from 0 to 9. If you do not set the Power Level, the oven sets itself to the highest level automatically.
4. Press the ENTER/START button again.

5. To retrieve a Favorite Cook setting, press the Favorite Cook button, then press the ENTER/START button.

- You can only recall one stored Custom Cook setting at a time.

6. If you want to set a new time and power level, repeat steps 1~5.

You can check the power level anytime while cooking by pressing the Power Level button.

## COOKWARE GUIDE

- For food to cook in the microwave oven, the microwaves must be able to penetrate the food without being reflected or absorbed by the dish.
- It is important to choose the correct cookware, therefore, look for cookware that is marked microwave-safe.
- The following table lists various types of cookware and indicates if and how they should be used in a microwave oven.



## MICROWAVE-SAFE UTENSILS

If you are not sure whether an item is microwave-safe, you can perform the following simple test:

1. Place 1 cup of water (in a glass-measuring cup) inside your oven next to the item to be tested.
2. Press the Add 30 sec button twice to heat them both for one minute at high power.

After one minute, the water should be warm and the item you are testing should be cool. If the dish is warm, then it is absorbing microwave energy and is not microwavesafe.

Cookware		Comments
<b>Aluminum foil</b>	⚠	Can be used in small quantities to protect areas against overcooking. Arcing can occur if the foil is too close to the oven wall or you use too much foil.
<b>Browning plate</b>	✓	Do not preheat for more than eight minutes.
<b>Ceramic, porcelain, and stoneware</b>	✓	Porcelain, pottery, glazed earthenware, and bone china are usually suitable, unless decorated with a metal trim.
<b>Disposable polyester cardboard</b>	✓	Some frozen foods are packaged in these materials.
<b>Fast-food packaging</b>		
Polystyrene cups/containers	✓	Can be used to warm food. Overheating may cause the polystyrene to melt.
Paper bags or newspaper	—	May catch fire.
Recycled paper or metal trims	—	May cause arcing.

Cookware		Comments
<b>Glassware</b>		
Oven-to-table ware	✓	Can be used, unless decorated with a metal trim.
Fine glassware	✓	Can be used to warm foods or liquids. Delicate glass may break or crack if heated suddenly.
Glass jars	✓	Regular glass is too thin to be used in a microwave, and can shatter.
<b>Metal</b>		
Dishes, Utensils	—	May cause arcing or fire.
Freezer bag twist ties	—	May cause arcing or fire.
<b>Paper</b>		
Plates, cups, napkins, and kitchen paper	✓	For short cooking times and warming. Also to absorb excess moisture.
Recycled paper	✓	Do not use recycled paper towels, which may contain metal and may catch fire or cause arcing.
<b>Plastic</b>		
Containers	✓	Can be used if heat-resistant thermoplastic. Some plastics may warp or discolor at high temperatures. Do not use Melamine plastic.
Cling film	✓	Can be used to retain moisture. Avoid wrapping the food too tightly. Take care when removing the film. Hot steam will escape.
Freezer bags	△	Only if boilable or oven-proof. Should not be airtight. Pierce with a fork if necessary.
<b>Wax or grease-proof paper</b>		✓
<b>Thermometer</b>		✓
		Use only those marked "Microwave-safe" and follow the directions. Check the temperature in several places. You can use conventional thermometers once the food has been removed from the oven.
<b>Straw, wicker, and wood</b>		△
		Use only for short-term heating, as these materials are flammable.

✓ : Recommended to use

△ : Use with Caution

— : Unsafe to use / Do not use

Microwave energy actually penetrates food, attracted and absorbed by the water, fat, and sugar in the food. The microwaves cause the molecules in the food to move rapidly. The rapid movement of these molecules creates friction and the resulting heat cooks the food.

## GENERAL MICROWAVE TIPS

- Dense foods, such as potatoes, take longer to heat than lighter foods. Foods with a delicate texture should be heated at a low power level to prevent them from becoming tough.
- Foods with a non-porous skin such as potatoes or hot dogs, should be pierced to prevent bursting. Putting heating oil or fat in the microwave is not recommended. Fat and oil can suddenly boil over and cause severe burns.
- Some ingredients heat faster than others. For example, the jelly in a jelly doughnut will be hotter than the dough. Keep this in mind to avoid burns.
- The altitude and the type of cookware you are using can affect the cooking time. When trying a new recipe, use the minimum cooking time and check the food occasionally to prevent overcooking.
- Home canning in the microwave oven is not recommended because not all harmful bacteria may be destroyed by the microwave heating process.
- Although microwaves do not heat the cookware, the heat from the food is often transferred to the cookware. Always use pot holders when removing food from the microwave and instruct children to do the same.
- Making candy in the microwave is not recommended as candy can be heated to very high temperatures. Keep this in mind to avoid injury.

### Cooking techniques

- If the oven is set to cook for more than 20 minutes, it will automatically adjust to 70 percent power after 20 minutes to avoid overcooking.
- Stirring: Open the microwave door and stir foods such as casseroles and vegetables occasionally while cooking to distribute heat evenly. Food at the outside of the dish absorbs more energy and heats more quickly, so stir from the outside towards the center. The oven will turn off when you open the door to stir your food.
- Arrangement: Arrange unevenly shaped foods, such as chicken pieces or chops, with the thicker, meatier parts toward the outside of the turntable where they can receive more microwave energy. To prevent overcooking, place thin or delicate parts towards the center of the turntable.
- Shielding: Shield food with narrow strips of aluminum foil to prevent overcooking. Areas that need shielding include poultry wing-tips, the ends of poultry legs, and corners of square baking dishes. Use only small amounts of aluminum foil. Larger amounts can damage your oven.
- Turning: Turn foods over midway through the cooking cycle to expose all parts to the microwave energy. This is especially important with large items such as roasts. Place the meat fat side down on a microwave-safe roasting rack in a microwave-safe dish. Use

narrow strips of aluminum foil to shield any bone tips or thin pieces of meat. Check the temperature in several places before letting the meat stand the recommended time. The following temperatures are the removal temperatures. The temperature of the food will rise during standing time

- **Standing:** Foods cooked in the microwave build up internal heat and continue to cook for a few minutes after the oven stops. Let foods stand to complete the cooking process, especially foods such as roasts and whole vegetables. Roasts need this time to complete cooking in the center without overcooking the outer areas. All liquids, such as soup or hot chocolate should be shaken or stirred when cooking is complete. Let liquids stand a moment before serving. When heating baby food, stir well and test the temperature before serving.
- **Adding moisture:** Microwave energy is attracted to water molecules. Food that is uneven in moisture content should be covered or allowed to stand so that the heat disperses evenly. Add a small amount of water to dry food to help it cook.
- **Venting:** After covering a dish with plastic wrap, vent the plastic wrap by turning back one corner to let excess steam escape.

## **COOKING MEAT**

Place the meat fat side down on a microwave-safe roasting rack in a microwave-safe dish. Use narrow strips of aluminum foil to shield any bone tips or thin pieces of meat. Check the temperature in several places before letting the meat stand the recommended time.

The following temperatures are the removal temperatures. The temperature of the food will rise during standing time

Food	Cooking time/ power level	Instructions
Roast beef (boneless) Up to 4 lbs.	<b>Cooking Time:</b> 3-9 min. / lb. for 145 °F - Rare 10-15 min. / lb. for 160 °F - Medium 12-17 min. / lb. for 170 °F - Well Done	Place the roast fat- side down on the roasting rack and cover with wax paper. Turn over halfway through the cooking process. Let stand for 10 to 15 minutes.
	<b>Power Level:</b> High (10) for first 5 minutes, then Medium (5).	
Pork (boneless or bone-in) Up to 4 lbs.	<b>Cooking Time:</b> 13-17 min. / lb. at 170 °F Well Done	Place the pork fat-side down on the roasting rack and cover with wax paper. Turn over halfway through cooking process. Let stand for 10 to 15 minutes.
	<b>Power Level:</b> High (10) for first 5 minutes, then Medium (5).	

The following temperatures are the removal temperatures. The temperature of the food will rise during standing time. Expect a 10 °F rise in temperature during the standing time.



Food		Remove from oven	After standing (10 MIN.)
Beef	Rare	135 °F	145 °F
	Medium	150 °F	160 °F
	Well Done	160 °F	170 °F
Pork	Medium	150 °F	160 °F
	Well Done	160 °F	170 °F
Poultry	Dark meat	170 °F	180 °F
	Light meat	160 °F	170 °F

## COOKING POULTRY

Place the poultry on a microwave-safe roasting rack in a microwave-safe dish and cover with wax paper to prevent spattering. Use aluminum foil to shield the bone tips, thin pieces of meat, or areas that may start to overcook. Check the temperature in several places before letting the poultry stand the recommended time.

Food	Cooking time/ power level	Instructions
Whole chicken Up to 4 lbs.	<b>Cooking Time:</b> 7-11 min. / lb. 180 °F dark meat 170 °F light meat	Place the chicken breast-side down on the roasting rack. Cover with wax paper. Turn over half way through cooking process. Cook until the juices run clear and the meat near the bone is no longer pink. Let stand for 5-10 minutes.
	<b>Power Level:</b> Medium High (7).	
Chicken pieces Up to 2 lbs.	<b>Cooking Time:</b> 7-10 min. / lb. 180 °F dark meat 170 °F light meat	Place the chicken bone-side down on the dish, with the thickest portions towards the outside of the dish. Cover with wax paper. Turn over halfway through the cooking process. Cook until the juices run clear and the meat near the bone is no longer pink. Let stand for 5-10 minutes.
	<b>Power Level:</b> Medium High (7).	

## COOKING SEAFOOD

Place the fish on a microwave-safe roasting rack in a microwave-safe dish. Use a tight cover to steam the fish. A lighter cover of wax paper or paper towel will decrease steaming. Cook the fish until it flakes easily with a fork. Do not over cook fish. Check it after the minimum cooking time.

Food	Cooking time/ power level	Instructions
Tuna steaks and salmon steaks Up to 1.5 lbs.	<b>Cooking Time:</b> 6-10 min. / lb.  <b>Power Level:</b> Medium-High (7).	Arrange the steaks on a roasting rack with the meaty portions towards the outside of the rack. Cover with wax paper. Turn them over halfway through the cooking process. Cook until the fish flakes easily with a fork. Let stand for 3-5 minutes.
Fillets Up to 1.5 lbs.	<b>Cooking Time:</b> 4-8 min. / lb.  <b>Power Level:</b> Medium-High (7).	Arrange the fillets in a baking dish, tucking any thin pieces under. Cover with wax paper. If the fillets are thicker than ½ in., turn them over halfway through the cooking process. Cook until the fish flakes easily with a fork. Let stand for 2-3 minutes.
Shrimp Up to 1.5 lbs.	<b>Cooking Time:</b> 4-6 min. / lb.  <b>Power Level:</b> Medium-High (7).	Arrange the shrimp in a baking dish without overlapping or layering them. Cover with wax paper. Cook until firm and opaque, stirring 2 or 3 times. Let stand for 5 minutes.

## COOKING EGGS

- You can use your microwave oven to cook eggs. Cook them until they are just set as they become tough if they are overcooked.
- **WARNING:** Never cook eggs in their shells and never warm up hard-boiled eggs in their shells. Eggs cooked or warmed up in their shells can explode. Always pierce whole eggs to keep them from bursting

## CLEANING AND MAINTAINING

Keeping your microwave oven clean improves its performance, wards off unnecessary repairs, and lengthens its life.

### CLEANING THE EXTERIOR

- It's best to clean spills on the outside of your microwave oven as they occur. Use a soft cloth and warm, soapy water. Rinse and dry.
- **CAUTION:** Do not get water into the vents. Never use abrasive products or chemical solvents such as ammonia or alcohol as they can damage the appearance of your microwave.

Cleaning under your microwave oven

- Regularly clean grease and dust from the bottom of your microwave using a solution of warm water and detergent

Cleaning the control panel

- Wipe with a damp cloth and dry thoroughly. Do not use cleaning sprays, large amounts of soap and water, abrasives, or sharp objects on the panel as it is easily damaged.

Cleaning the door and door seals

- Always ensure that the door seals are clean and that the door closes properly. Take particular care when cleaning the door seals to ensure that no particles accumulate and prevent the door from closing correctly. Wash the glass door with very mild soap and water. Be sure to use a soft cloth to avoid scratching.
- If a thin film of water accumulates on the inside or outside of the oven door, wipe it off with a soft cloth. A thin water film can accumulate when you operate the oven at high humidity and in no way indicates microwave leakage.

### CLEANING THE INTERIOR

- Ensure that the microwave oven has cooled down before cleaning it to avoid injury.

- **CAUTION:** Remove the glass tray from the oven when cleaning the oven or tray. To prevent the tray from breaking, handle it with care and do not put it in water immediately after cooking. Wash the tray carefully in warm sudsy water or in the dishwasher.
- Clean the interior surfaces (oven cavity) of your microwave oven periodically to remove any splashes or stains. To remove hardened food articles and remove smells, place 2 cups of water (add lemon juice for extra freshness) into a four-cup measuring glass. Run the microwave at High power for 5 minutes or until the water boils. Let water stand in the oven for one or two minutes.

## **CLEANING THE TURNTABLE AND ROLLER RINGS**

- Clean the roller rings periodically and wash the turntable as required. You can wash the turntable safely in your dishwasher.

## **STORING AND REPAIRING YOUR MICROWAVE OVEN**

If you need to store your microwave oven for a short or extended period of time, choose a dust-free, dry location. Dust and dampness may adversely affect the ability of the microwave parts.

- Do not repair, replace, or service any part of your microwave oven yourself. Allow only a qualified service technician to perform repairs. If the oven is faulty and needs servicing, or you are in doubt about its condition, unplug the oven from the power outlet and contact your nearest service center.
- Do not use the oven if it is damaged, in particular, if the door or door seals are damaged. Door damage includes a broken hinge, a worn out seal, or a distorted/bent casing.
- Do not remove the oven from its casing.
- This microwave oven is for home use only and is not intended for commercial use.

## **REPLACING THE COOKTOP/NIGHT LIGHT**

When replacing the cooktop/night light, make sure that you are wearing gloves to avoid injury from the heat of the bulb.

1. Unplug the oven or turn off the power at the main power supply.
2. Remove the screw from the light cover and lower the cover.
3. Replace the bulb with a 40 watt incandescent bulb.
4. Replace the light cover and mounting screw.
5. Turn the power back on at the main power supply.

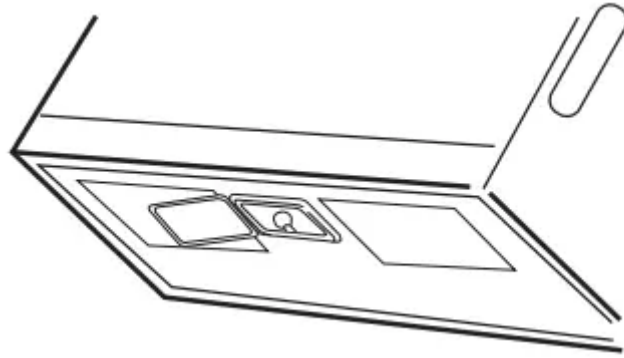

## REPLACING THE OVEN LIGHT

When replacing the oven light, make sure that you are wearing gloves to avoid injury from the heat of the bulb.

1. Unplug the oven or turn off the power at the main power supply.
2. Open the door.
3. Remove the vent cover mounting screws (2 middle screws).
4. Slide the vent grille to the left, then pull it straight out.
5. Remove the charcoal filter, if present.
6. Remove the cover by pushing the hook and pulling up the lever.
7. Remove the bulb by turning it gently
8. Replace the bulb with a 40 watt appliance bulb.
9. Replace the bulb holder.
10. Replace the vent grille and the 2 screws.
11. Turn the power back on.

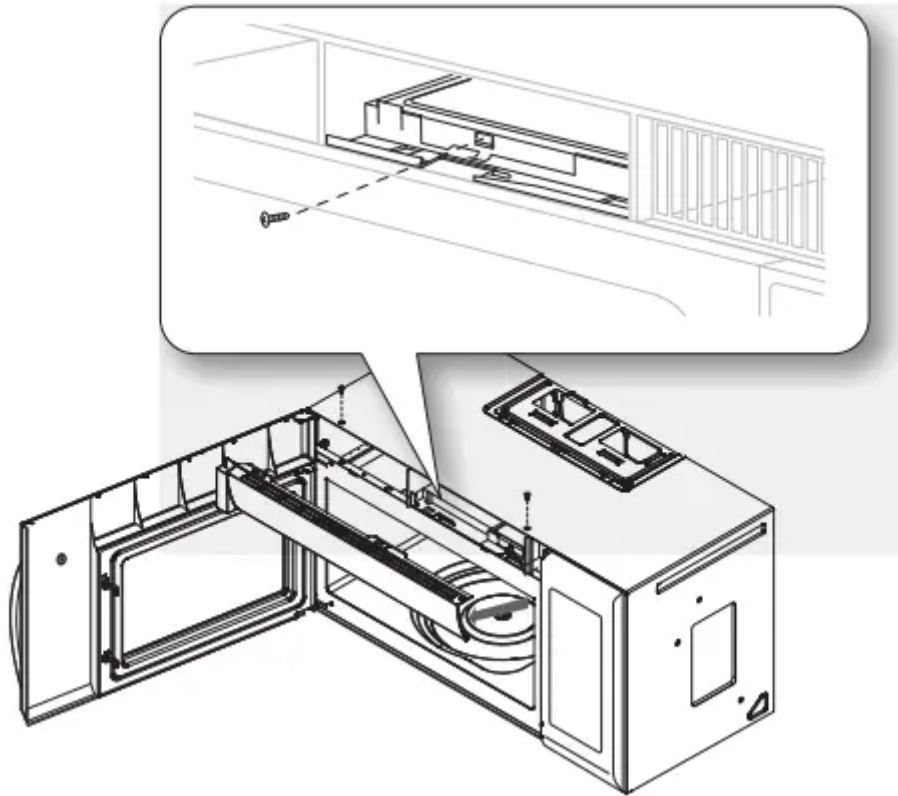

## CLEANING THE GREASE FILTER

Your microwave oven has two metal reusable grease filters. The grease filters should be removed and cleaned at least once every four month, or as required.

Your microwave oven has a filter reminder function. See page 10 for details.

**WARNING:** To avoid risk of personal injury or property damage, do not operate the oven hood without the filters in place.

1. To remove the filter, slide it to the left (or right) using the tab.

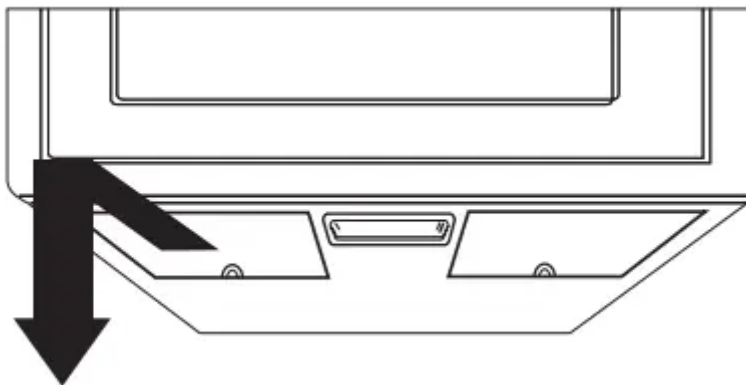

2. Soak the grease filter in hot water and a mild detergent. Rinse well and shake to dry. Brushing the filter lightly can remove embedded dirt. **WARNING:** Do not use ammonia or put the grease filter in the microwave oven. The aluminum will darken.

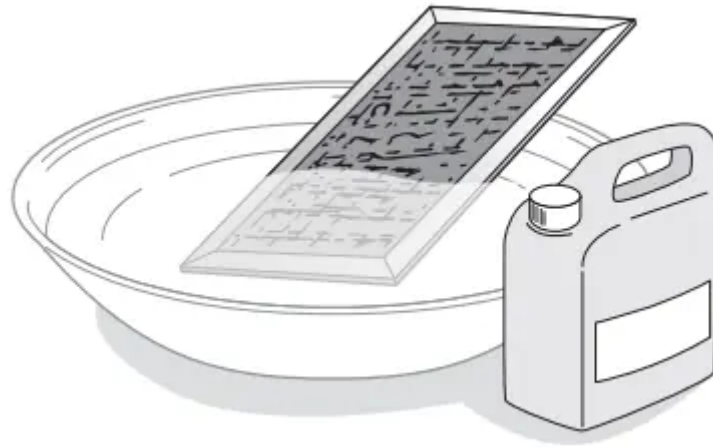

3. To re-install the filter, slide it into the frame slot on the left (or right), and then push it upwards and to the right (or left) to lock it.

## **REPLACING THE CHARCOAL FILTER**

If your oven is vented to the inside, the charcoal filter should be replaced every 6 to 12 months and more often if necessary. The charcoal filter cannot be cleaned. To order a new charcoal filter, contact the Parts Department or your Samsung dealer. You can also order online at [www.samsungparts.com](http://www.samsungparts.com)

1. Unplug the oven or turn off the power at the main power supply.
2. Open the door.
3. Remove the vent grille mounting screws (2 middle screws).
4. Slide the vent grille to the left, then pull it straight out.

5. Push the hook and remove the old filter.

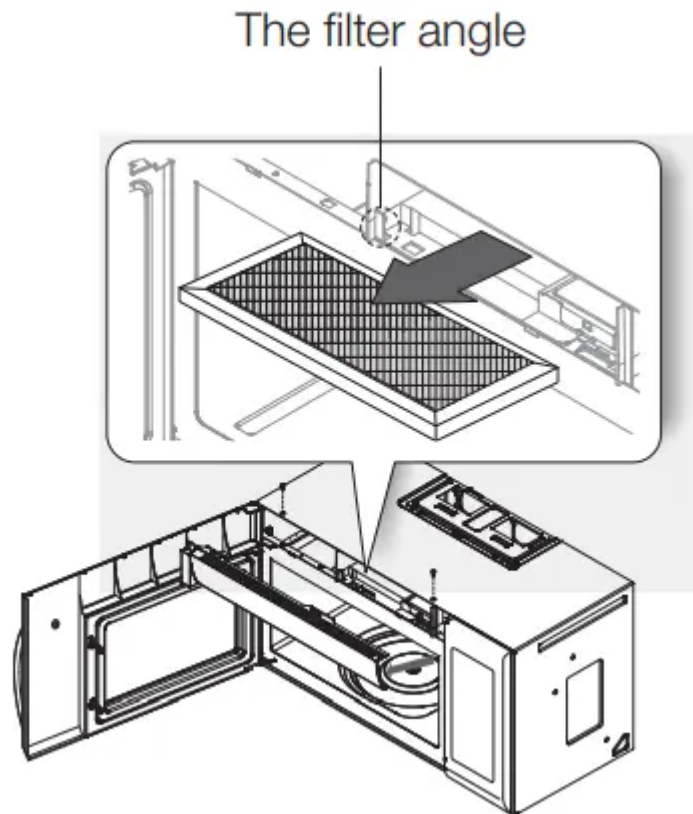

6. Slide a new charcoal filter into place. The filter should rest at the angle shown

7. Replace the vent grille and 2 screws and close the door. Turn the power back on and set

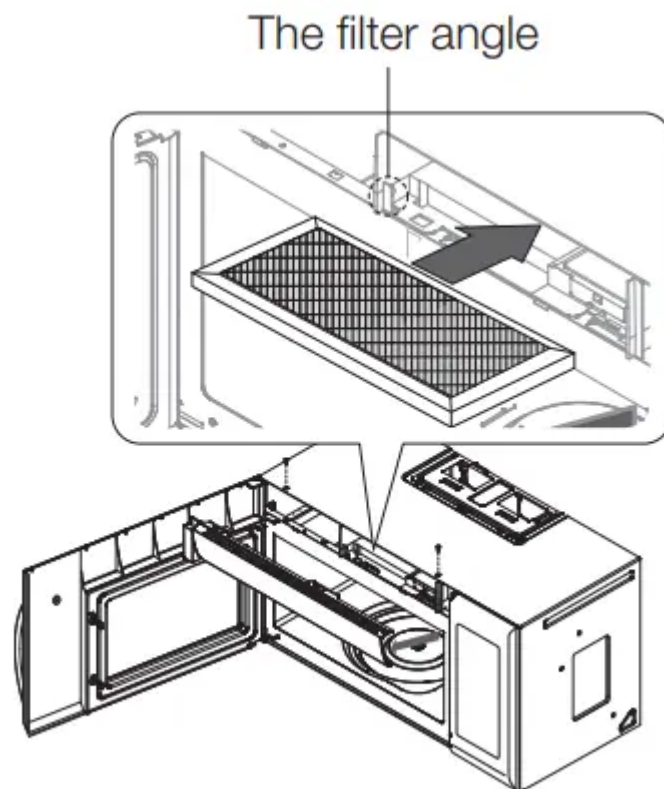

the clock

## TROUBLESHOOTING

Check these solutions if you have a problem with your microwave:

1. The display and/or the oven is not working.

- Make sure the plug is properly connected to a grounded outlet. If the wall outlet is controlled by a wall switch, make sure the wall switch is turned on.
- Remove the plug from the outlet, wait ten seconds, and plug it in again.
- Reset the circuit breaker or replace any blown fuses.
- Plug a different appliance into the outlet. If the other appliance doesn't work, call a qualified electrician to repair the wall outlet.
- Plug the oven into a different outlet.

2. The display is working, but the power won't come on

- Make sure the door is closed securely. Check if any packaging material or anything else is stuck in the door seal. Check if the door is damaged.
- Touch Cancel twice and enter all the cooking instructions again.

3. Is the power going off before the set time has elapsed?

- If there was a power outage, the time indicator will display: 88:88.
- If no power outage occurred, remove the plug from the outlet, wait ten seconds, and plug it in again.
- Reset the clock and any cooking instructions.
- Reset the circuit breaker or replace any blown fuses.

4. Cooks food too slowly.

- Make sure the oven has its own 20 amp circuit line. Operating another appliance on the same circuit can cause a voltage drop. If necessary, move the oven to its own circuit.

5. Has sparks or arcing.

- Remove any metallic utensils, cookware, or metal ties. If using foil, use only narrow strips and allow at least one inch between the foil and the interior oven walls.

6. The turntable makes noise or becomes stuck.

- Clean the turntable, roller ring, and oven floor.
- Make sure the turntable and roller ring are positioned correctly

7. Causes TV or radio interference.

- This is similar to interference caused by other small appliances, such as hair dryers. Move your microwave (or appliance) away from appliances, such as your TV or radio.

8. Vent Motor suction force is too weak.

- Set the vent mode to high. The Vent Fan will only operate in low speed mode while the microwave is working.

9. Operating noise is too loud.

- The MWO makes noise during operation. This is normal. If you hear an abnormal sound continuously, please contact the Samsung Call Center

10. Cook top lamp is too dim.

- Set the lamp brightness level to high.

11. Difficult to replace Charcoal Filter.

- Please refer to the instructions for replacing the charcoal filter in the user's manual.

12. Turntable rotates improperly.

- Make sure you have not put too much food on the turntable.
- If the food is too large or too heavy, the turntable may operate improperly

**Warning**

This content is compiled from multiple sources and is provided for reference purposes only. It may not be complete or fully applicable to all situations. If you are unable to resolve your issue, please contact the product manufacturer or an authorized service provider for official support.