

OPERATING INSTRUCTIONS

Features

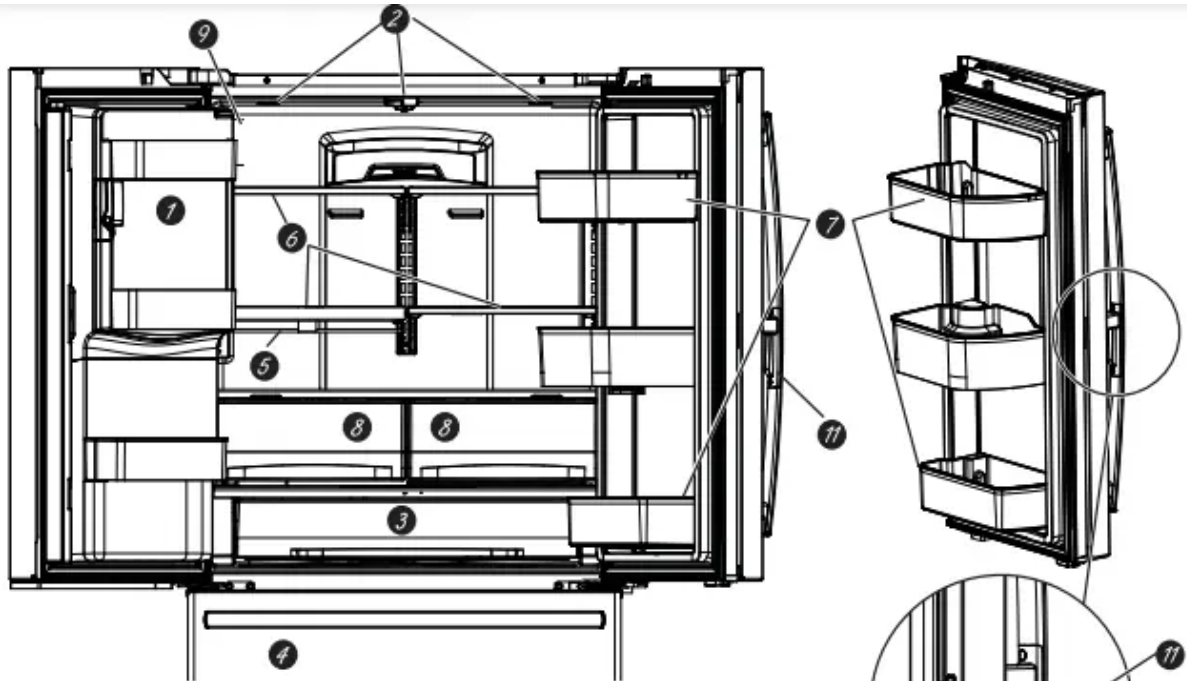

- 1 Space-saving ice maker***
Ice maker and bin are located on the door creating more usable storage space.
- 2 Showcase LED lighting**
LED lighting is positioned throughout the interior to spotlight areas in the refrigerator. LEDs are located under the fresh food door to light the freezer when opened.
- 3 Full-width temperature controlled drawer**
Adjustable temperature control bin that can accommodate larger items.
- 4 Freezer ice maker/Ice Bin***
An ice maker in both compartments give you more ice whenever you need it. Available on Non-Dispense models, also available as a kit for some models.
- 5 QuickSpace™ shelf***
Functions as a normal full-sized shelf when needed and easily slides back to store tall items below.
- 6 Spillproof shelves**
Designed to capture your spills for easier clean up.
- 7 Removable door bin**
Can be removed for those with a wall limiting the door opening.
- 8 Climate zone bin**
Separate bins for produce storage.
- 9 Water filter**
Filters water and ice.
- 10 Rotating Bin***
Can be rotated out for easy access.
- 11 Door in Door Latch***
Squeeze the latch on the underside of the handle to open the outer door.

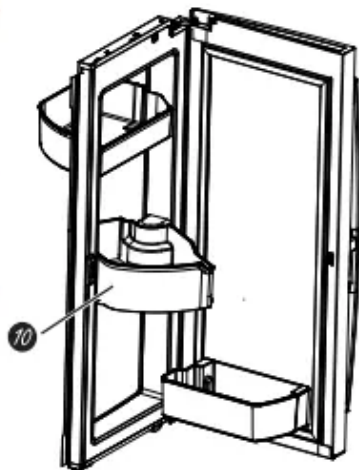

* Select models only

1. Door ice bin*

- Open left fresh food door.
- Pull down latch to release bin door.
- Using handhold lift ice bucket up and out to clear locators in bottom of bin
- To replace the ice bucket, set it on the guide brackets and push until the ice bucket seats properly.
- If bucket cannot be replaced, rotate the Ice Bucket Fork 1/4 turn clockwise

2. Ice/water filter: Certified to reduce chlorine-resistant cysts, lead, select pharmaceuticals, and more. For easy filter replacement instructions

- The first time the hot water feature is used, confirm if you live above 5000 feet (1524 meters) (high altitude). This limits the temperature of the hot water system to avoid boiling. To access the high altitude selection, see Controls.

Controls

PFE28P, PYE22P Control Style A, Single Serve Models

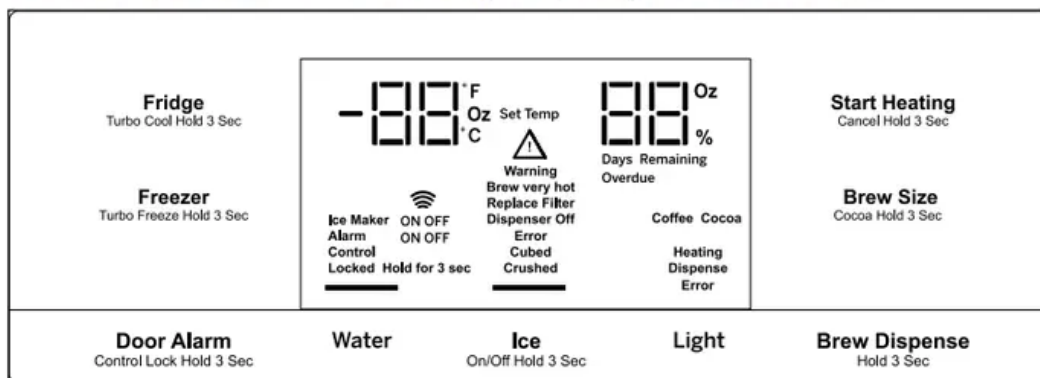

PFH28, PFE28K, DFE28, PFD28, PYE22K, PYD22, DYE22 Control Style B, AutoFill Models

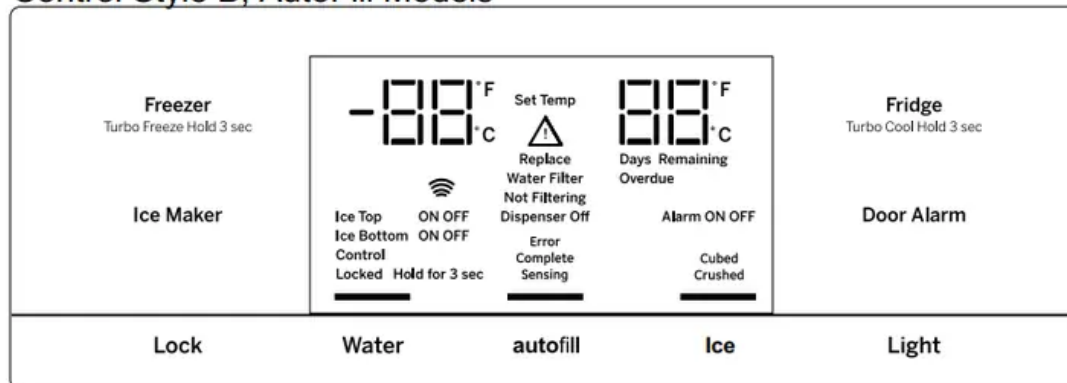

GFD28, GFE28, GFE26, GFS26, GYS22, GYE22 Control Style C, GE Models

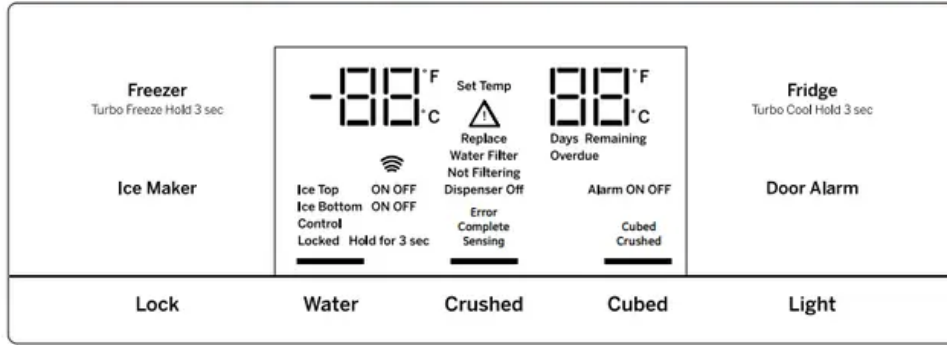

GNE29, PWE23 Control Style D, Non-Dispense Control

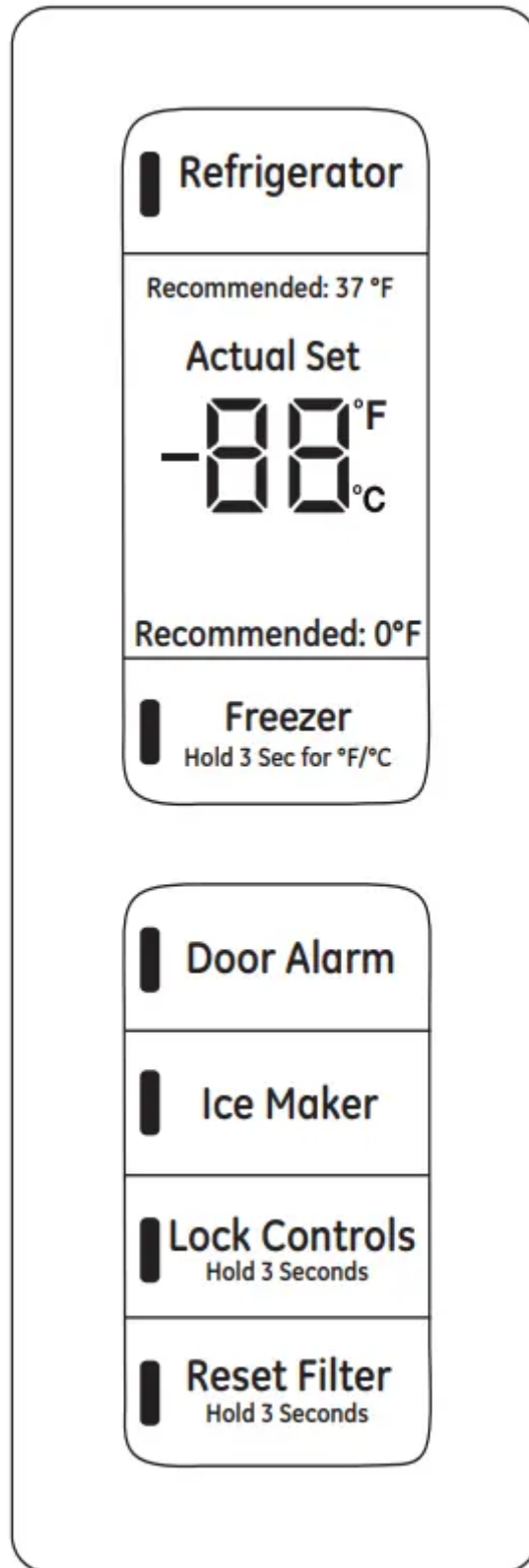

- NOTE: The refrigerator is shipped with protective film covering the temperature controls. If this film was not removed during installation, remove it now.

- The temperature controls are preset in the factory at 37°F for the refrigerator compartment and 0°F for the freezer compartment. Allow 24 hours for the temperature to stabilize to the preset recommended settings.
- Control Style D: The temperature controls can display both the SET temperature as well as the actual temperature in the refrigerator and freezer. The actual temperature may vary slightly from the SET temperature based on usage and operating environment (PWE23 and GNE29 only).

Changing the Temperature for Control Style A

- To Change the Refrigerator Temperature: Press the Fridge button and current set temperature will display. Pressing and releasing the button will cycle through the available temperature settings. Press and hold button for Turbo Cool feature. The display will show tC.
- To Change the Freezer Temperature: Press the Freezer button and current set temperature will display. Pressing and releasing the button will cycle through the available temperature settings. Press and hold button for Turbo Freeze feature. The display will show tF.
- Cooling system can be turned off by pressing and holding Freezer and Start Heating. OFF will be displayed. To turn on, press Fridge or Freezer. ON will be displayed. Turning the cooling system off stops the cooling to the refrigerator, but it does not shut off the electrical power.

Changing the Temperature for Control Styles B and C

- To change the temperature, press and release the Freezer or Fridge pad. The display will show the set temperature. To change the temperature, press either the Freezer or Fridge pad until the desired temperature is displayed. Press and hold button for Turbo Cool feature. The display will show tC. Press and hold button for Turbo Freeze feature. The display will show tF.
- To turn off the cooling system press and hold the Fridge and Ice Maker buttons. To turn on, press Fridge or Freezer.
- Turning the cooling system off stops the cooling to the refrigerator, but it does not shut off the electrical power

Changing Temp. for Control Style D

- Temperature Display is located on inside of left - hand refrigerator door. To change the temperature, press and release the REFRIGERATOR or FREEZER pad. The ACTUAL TEMP light will come on and the display will show the actual temperature. To change the temperature, tap either the REFRIGERATOR or FREEZER pad until the desired temperature is displayed.

- To turn OFF cooling system, press and hold the REFRIGERATOR and FREEZER pads simultaneously for 3 seconds. When cooling system is OFF the display should read OF. To turn ON cooling system, press either REFRIGERATOR or FREEZER pad. The display will show the preset temperature settings of 37°F (3°C) for refrigerator and 0°F (-18°C) for freezer
- Turning the cooling system off stops the cooling to refrigerator, but it does not shut off the electrical power.

Control Style A, External Controls PFE28P, PYE22P

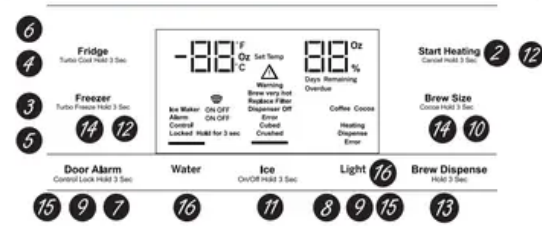

Control Style B, External Controls PFH28, PFE28K, DFE28, PFD28, PYE22K, PYD22, DYE22



Control Style C, External Controls GFD28, GFE28, GFE26, GFS26, GYE22, GYS22

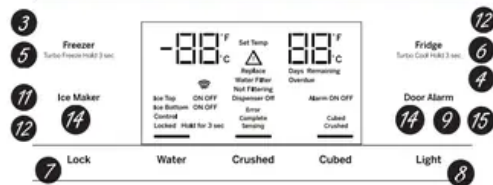

- 1 **Hands-free Autofill***
Hands-free Autofill uses sensors to monitor container height to automatically dispense filtered water without having to activate the paddle.
- 2 **Start Heating***
The Start Heating button is used to initiate the water heating for the Single Serve feature. To abort the Start Heating feature, press and hold the Start Heat button for 3 seconds.
- 3 **Freezer temp control**
Adjust freezer compartment temperature.
- 4 **Fresh food temp control**
Adjust fresh food compartment temperature.
- 5 **TurboFreeze™ setting**
Activate **TurboFreeze** to quickly restore freezer temperatures after frequent door openings.
- 6 **TurboCool™ setting**
Activate **TurboCool** to quickly restore fresh food temperature after frequent door openings.
- 7 **Lock Controls**
Control Style A - Press and hold the **Door Alarm** pad for 3 seconds to lock out ice and water dispenser and all feature and temperature buttons.
Control Styles B & C - Press **Lock** pad and hold 3 seconds to lock out ice and water dispenser and all feature and temperature buttons.
- 8 **Dispenser light**
Lighting that can be turned on/off to light your dispenser.
- 9 **Door Alarm**
Sounds to alert when the freezer or fresh food doors have been left open. Press and hold **Door Alarm** pad and it will toggle the sound between low, high, and off.
- 10 **Brew Size***
The Brew Size button is used to select the desired cup size for single serve. Press and hold the button for 3 seconds to toggle the brew type between **Coffee** and **Cocoa**.
- 11 **Ice maker setting**
Turn your ice makers on/off.
- 12 **Cooling system On/Off**
Control Style A - Press and hold **Freezer** and **Start Heating** simultaneously to turn cooling system off. To turn cooling system on press either the **Fridge** or **Freezer**.
Control Style B & C - Press and hold **Fridge** and **Ice Maker** simultaneously for 3 seconds to turn the cooling system off. To turn cooling system on press either the **Fridge** or **Freezer**.
- 13 **Brew Dispense**
Press and hold **Brew Dispense** button for 3 seconds, but no longer than 6 seconds, to dispense coffee or cocoa.
- 14 **F°/C°**
Control Style A - Press and hold **Freezer** and **Brew Size** to switch between F°/C°.
Control Style B & C - Press and hold **Ice Maker** and **Door Alarm** simultaneously for 3 seconds to switch between F°/C°.
- 15 **Sound Control for pad chimes**
Control Style A - Press and hold the **Light** pad: Once for High to Off, twice for Off to Low and three times for Low to High.
Control Styles B & C - Press and hold the **Door Alarm** pad: Once for High to Off, twice for Off to Low and three times for Low to High.
- 16 **High Altitude**
Control Style A (PYE and PFE only) - Press and hold **Fridge** and **Door Alarm** for to toggle between Hi AL and Lo AL for high altitude and low altitude.

Additional settings:

- Connected Home ready* (PFE28P, PYE22P, PFH only)
- Water Filter* - An indicator will illuminate when the filter needs to be replaced. When a new filter is installed the indicator will go off.

Additional Mode:

- **Sabbath Mode**
Control Style A - Press and hold **Alarm** and **Light** simultaneously for 3 seconds to enter/exit Sabbath mode.
Control Style B & C - Press and hold **Lock** and **Light** simultaneously for 3 seconds to enter/exit Sabbath mode. Sabbath Mode will turn off or dim interior lights, temperature control and advanced features. Compressor will run on a timed defrost when in Sabbath mode.

*Select Models Only

Controls Style D, Internal Controls GNE29, PWE23



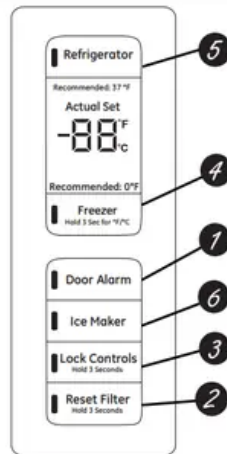

- 1 Door Alarm**
Sounds to alert when the freezer or fresh food doors have been left open.
- 2 Reset Filter**
Hold for 3 seconds after replacing filter.
- 3 Lock Controls**
Press and hold 3 seconds to lock out ice and water dispenser and all feature and temperature buttons.
- 4 Freezer temp control**
Adjust freezer compartment temperature
- 5 Refrigerator temp control**
Adjust fresh food compartment temperature
- 6 Ice maker setting**
Turn your ice maker on/off.

Additional Mode:

- Sabbath Mode Press and hold Door Alarm and Ice Maker simultaneously for 3 seconds to enter/ exit Sabbath mode.

Dispenser*

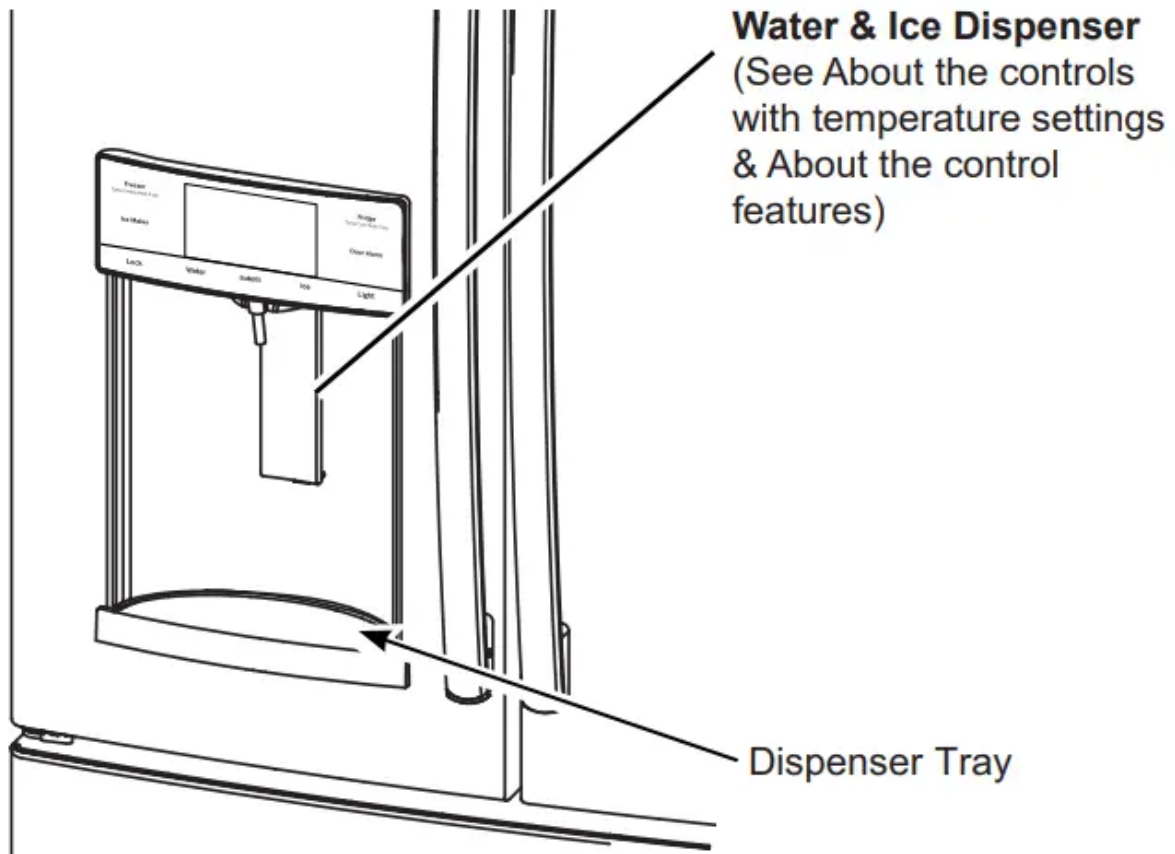

- If no water is dispensed when the refrigerator is first installed, there may be air in the water line system. Press the dispenser paddle for at least five minutes to remove trapped air from the water line and to fill the water system. To flush out impurities in the water line, throw away the first six full glasses of water
- To remove Dispenser Tray (Type A and B Only)
 - Pull Dispenser Tray out until it stops.
 - Locate tab in the center on the bottom and push up.
 - Pull Dispenser Tray assembly out
 - Lift Dispenser Tray out at center notch to clean
- To remove Dispenser Tray (Type C Only): Grasp Dispenser Tray and pull firmly until it comes out.
- To reinstall Dispenser Tray (Type A and B Only)
 - Place the Dispenser Tray cover on top of catch tray and position under the two plastic retainers on either side.
 - Center Dispenser tray, and align with center guides.
 - Push in until locks firm in place.

- To reinstall Dispenser Tray (Type C Only)> Line up the guide on tray bottom with track on dispenser and side it in until it stops against the back of the dispenser

Important Facts About Your Dispenser

- Do not add ice from trays or bags to the door ice maker bucket. It may not crush or dispense.
- Avoid overfilling glass with ice and use of narrow glasses. Backed-up ice can jam the chute or cause the door in the chute to freeze shut. If ice is blocking the chute remove the ice bucket. poke it through with a wooden spoon.
- Beverages and foods should not be quick-chilled in the door ice maker bin. Cans, bottles or food packages in the storage drawer may cause the ice maker or auger to jam.
- To keep dispensed ice from missing the glass, put the glass close to, but not touching, the dispenser opening.
- Some crushed ice may be dispensed even though you selected CUBED ICE. This happens occasionally when a few cubes accidentally get directed to the crusher.
- After crushed ice is dispensed, some water may drip, from the chute
- Sometimes a small mound of snow will form on the door in the ice chute. This condition is normal and usually occurs when you have dispensed crushed ice repeatedly. The snow will eventually evaporate.

To Use the Internal Water Dispenser*

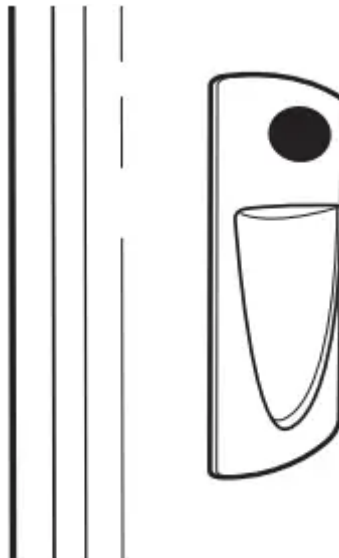

The water dispenser is located on the left wall inside the refrigerator compartment.

To dispense water:

1. Hold the glass against the recess.
2. Push the water dispenser button.

3. Hold the glass underneath the dispenser for 2–3 seconds after releasing the dispenser button. Water may continue to dispense after the button is released

If no water is dispensed when the refrigerator is first installed, there may be air in the water line system. Press the dispenser button for at least 5 minutes to remove trapped air from the water line and to fill the water system. During this process, the dispenser noise may be loud as the air is purged from the water line system. To flush out impurities in the water line, throw away the first 6 glassfuls of water.

NOTE: To avoid water deposits, the dispenser should be cleaned periodically by wiping with a clean cloth or sponge.

AUTOFILL*

To Use HANDS FREE AUTOFILL

- Center container on Recess Dispenser Tray as far back as possible without activating paddle and remove rand from container
- Press AUTOFILL.

To Stop AUTOFILL

- Press AUTOFILL to stop.

Important Facts about AUTOFILL.

- For optimum results, use a uniform container between 4-8" (10-20 cm) tall and 2-6" (5-15 cm) wide
- Fill level and functionality may vary on containers taller than 8" (20 cm) or wider than 6" (15 cm)
- Container volumes may vary, if error message "Not Found" is given, try a different container
- AUTOFILL will time out
- Handles, straws, and garnishes on the rim of the container may cause overflowing or variation in fill volumes.
- Splashing may occur depending on the location of the container, water flow rate, container shape, and ice cubes
- Keep sensors clean with a clean damp cloth. and do not spray liquid or cleaners directly on sensors
- AUTOFILL works best with household water pressure of 60 to 100 psi (414 to 689 kPa)
- Ice in container may affect fill volume. If issues are experienced, use less ice.

Water Filter Cartridge - RPWFE

Water Filter Cartridge

- The water filter cartridge is located in the fresh food interior on the left side wall, near the top.
- Select models use radio frequency identification (RFID) to detect leaks and monitor filter status. The RFID technology is certified by the FCC

FCCID: ZKJ-EBX1532P001 ICID: 10229A-EBX1532P001 "This device complies with part 15 of the FCC Rules. Operation is subject to the following two conditions: (1) This device may not cause harmful interference, and (2) this device must accept any interference received, including interference that may cause undesired operation." "This device complies with Industry Canada licenceexempt RSS standard(s). Operation is subject to the following two conditions: (1) this device may not cause interference, and (2) this device must accept any interference, including interference that may cause undesired operation of the device."

When to Replace the Filter Cartridge

- The filter cartridge should be replaced every six months or earlier if 170 gallons (643.52 liters) or water has been dispensed or the flow of water to the dispenser or icemaker decreases.
- Touch Screen Models: A filter status message will appear on the screen when the water filter needs to be replaced. The filter status will automatically update when the filter is replaced.
- Non-touch Screen Models: A filter indicator light will illuminate on the screen when the water filter needs to be replaced.

Removing the Filter Cartridge/Bypass Plug

1. Remove the old cartridge or bypass plug by opening the filter door and pulling on the bottom of the cartridge! bypass plug to disengage it from the filter clips. Swing the cartridge/bypass plug outward until you hear the click' of the cartridge holder engaging with the bracket.
2. Twist the cartridge/bypass plug one-quarter turn counter-clockwise. After twisting, remove the cartridge! bypass plug by pulling it away from the cartridge holder. A small amount of water may drip out.

Installing the Filter Cartridge/Bypass Plug

1. Align the filter cartridge/bypass plug with the cartridge holder with the word "FRONT" facing the top of the unit. Push the cartridge/bypass plug toward the rear of the unit until it is fully seated. Twist the filter cartridge! bypass plug clockwise one-quarter turn. until the word "FRONT" is facing outward.

Red indicators
should not be
visible

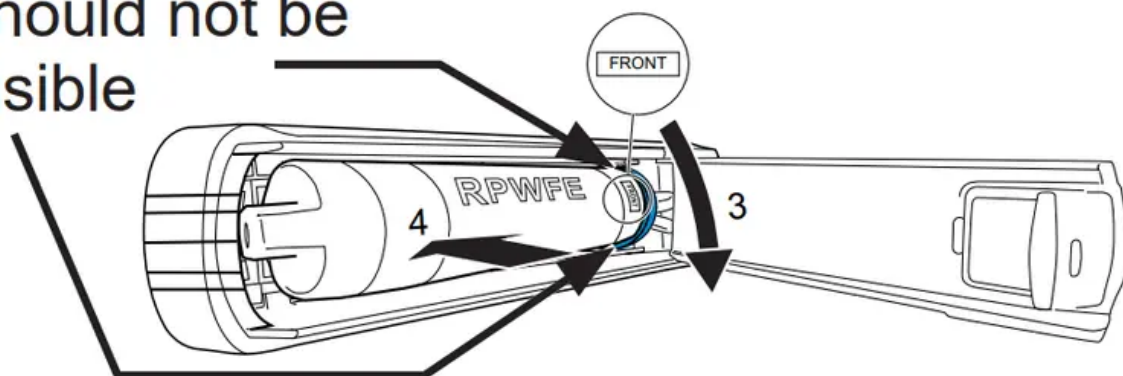

2. While continuing to ensure cartridge/bypass plug is fully seated in the holder, gently swing the filter inward until it is in position. If filter will not swing easily, check to ensure filter is properly aligned and fully seated within the cartridge holder. The RED indicators should not be visible.

NOTE: It is normal for water to appear discolored during the initial system flush. Water color will return to normal after first few minutes of dispensing.

Filter Bypass Plug

- To reduce the risk of property damage due to water leakage, you **MUST** use the filter bypass plug when a replacement filter cartridge is not available. Some models do not come equipped with the filter bypass plug. To obtain a free bypass plug, visit us on-line at geappliances.com/service. In Canada, visit geappliances.ca/service. The dispenser and icemaker will not operate without either the filter or the bypass plug installed. The bypass plug is installed in the same way as a filter cartridge.”

Fresh Food Storage Options

Rearranging the Shelves:

- Shelves in the refrigerator compartment are adjustable.
- To remove:
 1. Remove all items from the shelf.
 2. Tilt the shelf up at the front.
 3. Lift the shelf up at the back and bring the shelf out.
- To replace:
 1. While tilting the shelf up, insert the top hook at the back of the shelf in a slot on the track.
 2. Lower the front of the shelf until the bottom of the shelf locks into place.

Spillproof Shelves

- Spillproof shelves have special edges to help prevent spills from dripping to lower shelves.

Quick Space Shelf *

- This shelf splits in half and slides under itself for storage of tall items on the shelf below.
- This shelf can be removed and replaced or relocated (just like spillproof shelves)
- NOTE: The back half of the Quick Space Shelf is not adjustable.

Right Door Bins

- FIXED BINS can easily be carried from refrigerator to work area.
- To remove: Lift bin straight up, then pull out.
- ROTATING BIN:
 - To remove: Rotate bin outward then lift straight up.
 - To remove Place hand under metal base and lift up. To remove Metal Base: Place hand under metal base and lift up.

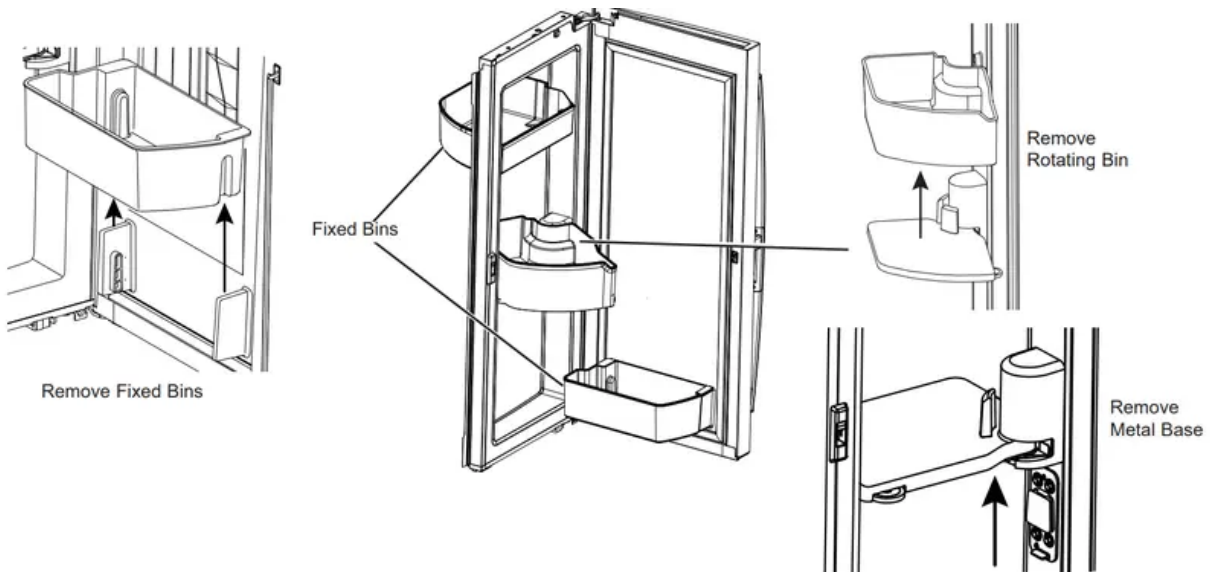

Left Door Bins

- DISPENSER MODELS - FIXED BIN* - To remove: Lift the bin straight up, then pull out. The ice maker door bins are not interchangeable, note the location upon removal and replace the bin in its proper location.

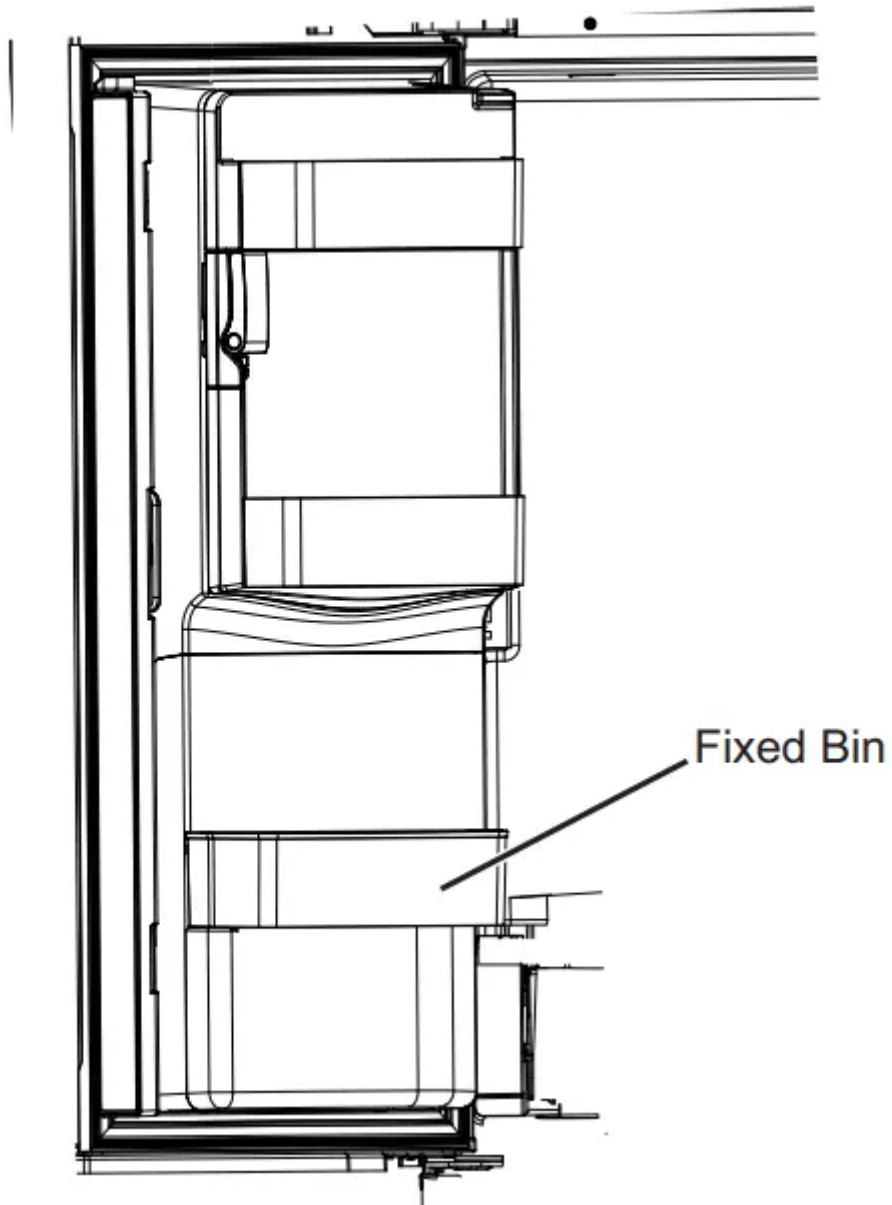

- NON-DISPENSER MODELS - ADJUSTABLE BINS* - Adjustable bins can easily moved up or down the inside of the door to give better flexibility for storage. To remove: Lift bin straight up, then pull out.

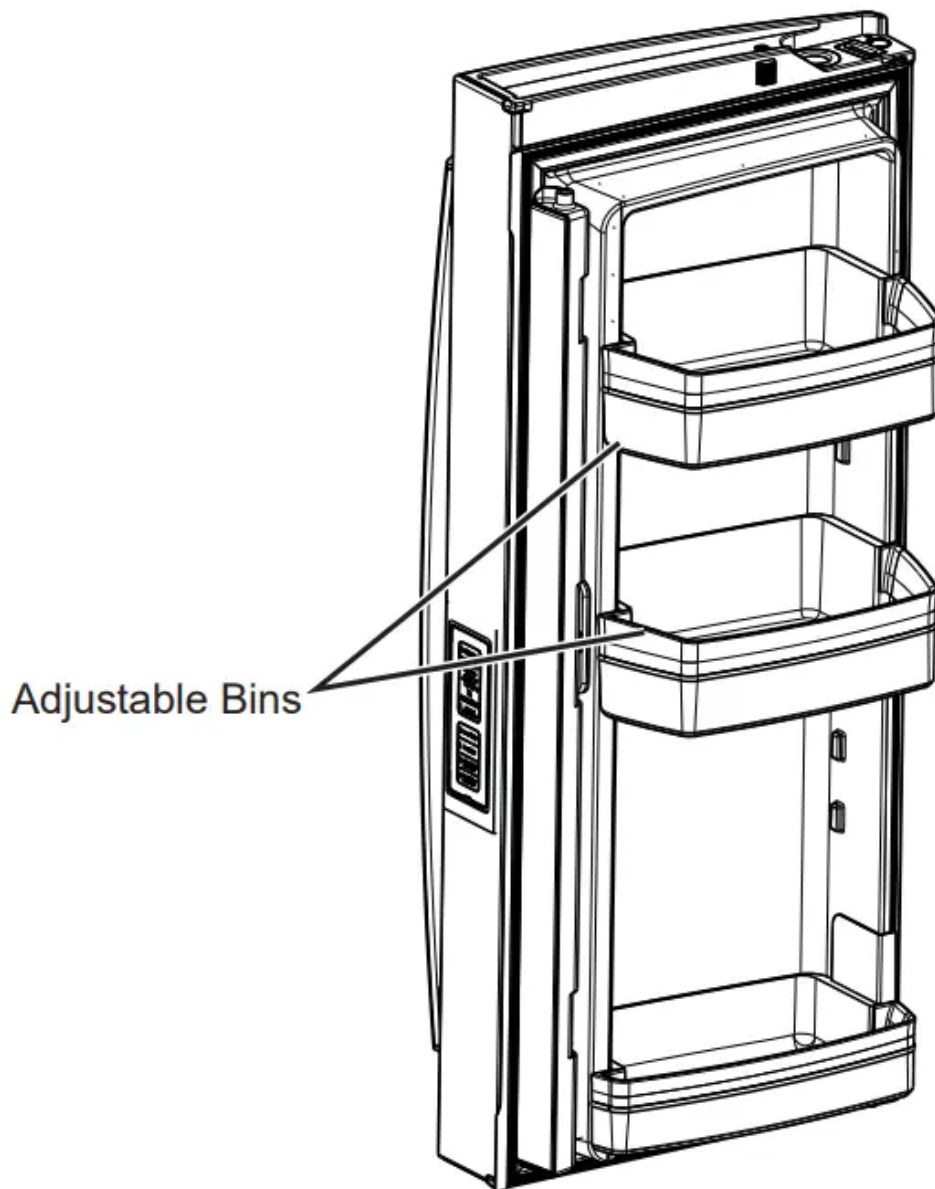

Climate Zone & Temperature Controlled Drawer

ClimateZone .

- Keep fruits and vegetables organized in separate compartments for easy access.
- Excess water that may accumulate in the bottom of the drawers or under the drawers should be wiped dry

Temperature Controlled Drawer*

- The temperature controlled drawer is a full - width drawer with adjustable temperature control. This drawer can be used for large miscellaneous items.
- To change setting, press select button

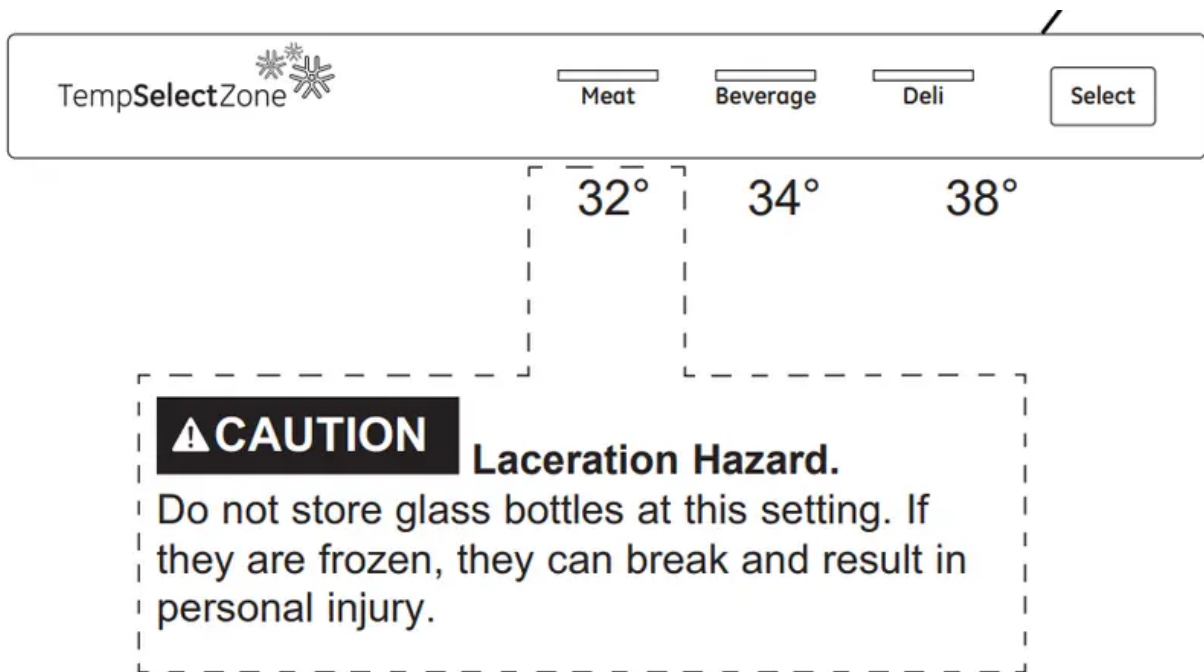

How to Remove and Replace Drawer

To remove:

1. Pull the drawer out to the stop position.
2. Lift the front of the drawer up and out.

To replace:

1. Pull left and right slides until fully extended.
2. Place drawer back in first and rotate drawer front down to seat on slide.
3. Push the drawer in to closed position.

How to Remove and Replace Drawer Divider*

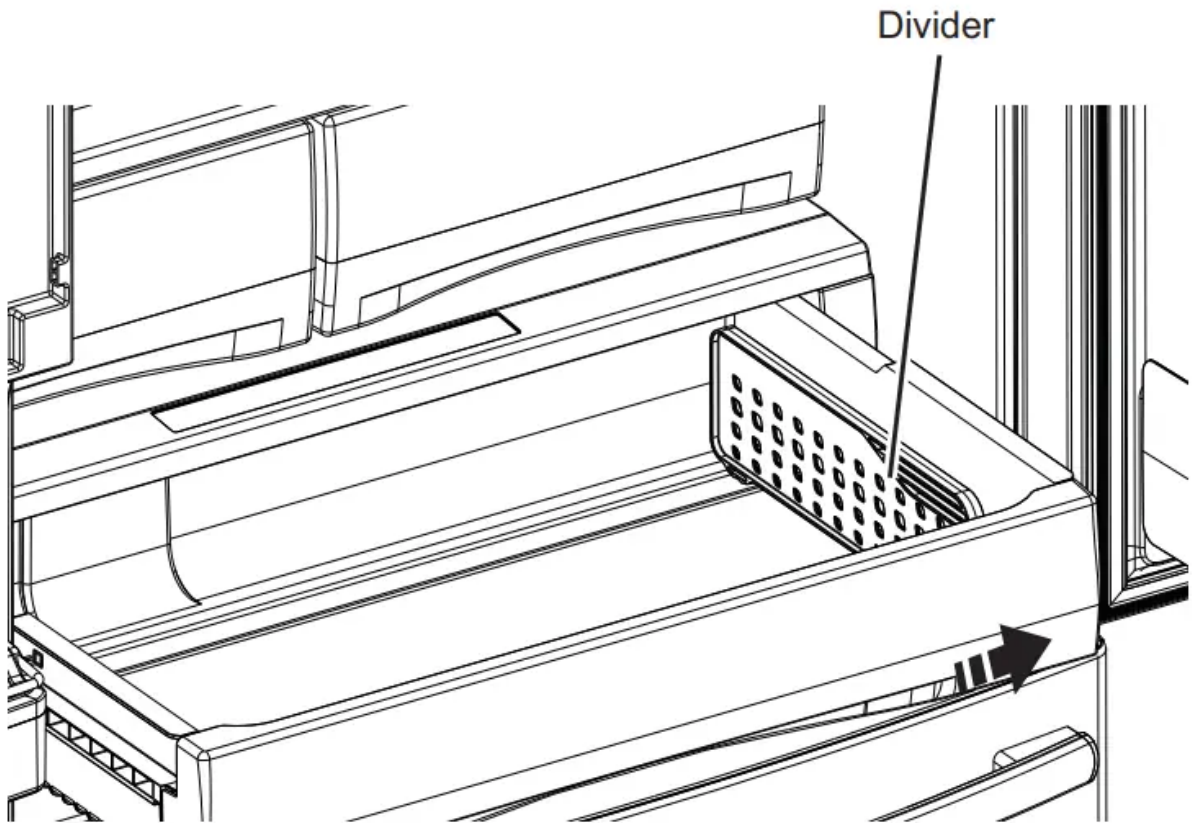

To remove:

1. Pull the drawer out to the stop position.
2. Raise the front side of the divider to unhook it from the rear wall of the drawer.

To replace:

1. Hook the back of the divider over the rear wall of the drawer.
2. Push the divider down.

Baskets, Drawers, and Bins

Freezer Basket and Drawer

1. Basket.
2. Drawer
3. Ice Bucket* (Available on Non - Dispense models only. Available as a IM Kit on some models)

Non-Adjustable Bin in the Freezer*

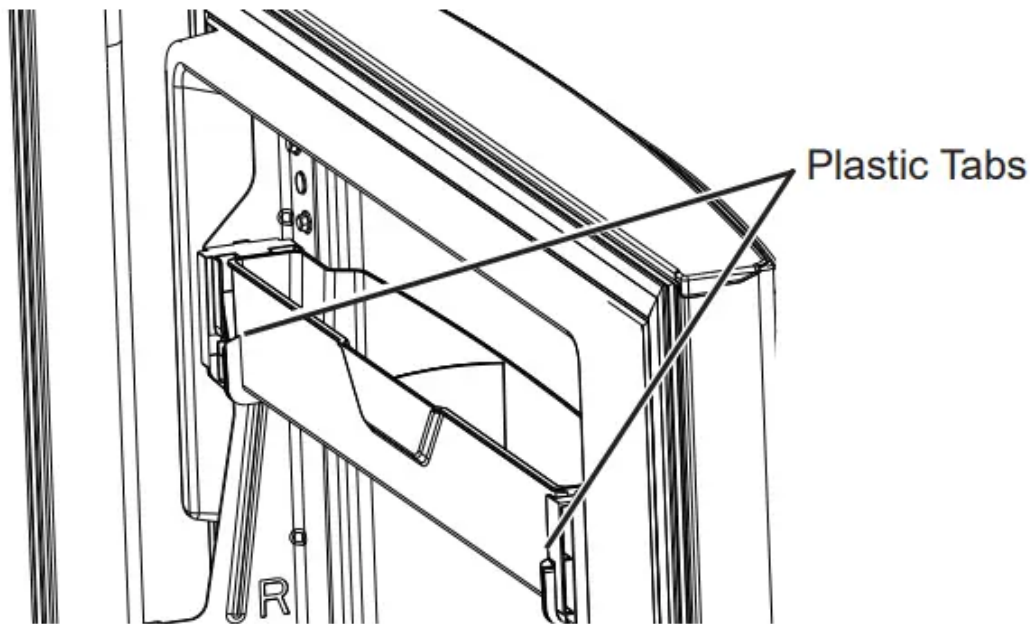

- To remove: Push in plastic tab on either left or right side
- To replace: Slide bin into location until it locks into place.

Basket Removal

To remove. standard depth models only:

1. Open freezer door to the stop position.
2. Remove freezer door bin by pushing plastic tab on either left or right side to release bin hinge pin.
3. Remove freezer basket by lifting up the rear of the basket and moving basket rearward until the front of the basket can be rotated upward and out.
4. Lift it out to remove.

To remove. counter depth models only:

1. Open fresh food doors.
2. Open freezer door to the stop position.
3. Remove freezer basket by lifting up the rear of the basket and rotate it upward.
4. Lift it out to remove.

To replace: Reverse step 1 through 4 to replace.

Automatic Ice Maker

A newly installed refrigerator may take 12 to 24 hours to begin making ice.

Automatic Ice maker*

- The ice maker will produce seven cubes per cycle approximately 100-130 cubes in a 24-hour period, depending on freezer compartment temperature, room temperature, number of door openings and other use conditions.
- The ice maker will fill with water when it cools to 15°F (10°C). A newly installed refrigerator may take 12 to 24 hours to begin making ice cubes.
- If the refrigerator is operated before the water line connection is made to the unit or if the water supply to an operating refrigerator is turned off, make sure that the ice maker is turned off. Once the water has been connected to the refrigerator, the ice maker may be turned on. See the table below for details.
- You may hear a buzzing sound each time the ice maker fills with water.
- Throw away the first few batches of ice to allow the water line to clear.

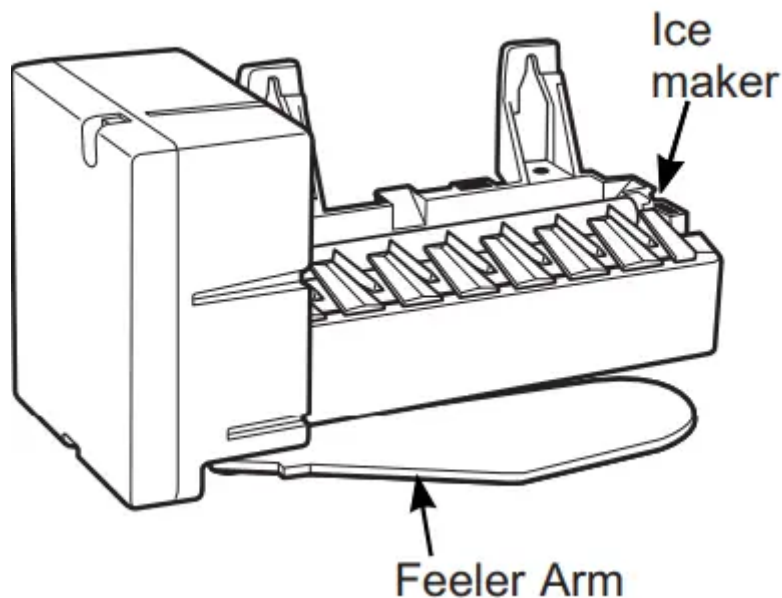

- Be sure nothing interferes with the sweep of the feeler arm.
- When the bin fills to the level of the feeler arm, the ice maker will stop producing ice. It is normal for several cubes to be joined together.
- If ice is not used frequently, old ice cubes will become cloudy, taste stale and shrink.
- NOTE: In homes with lower-than-average water pressure, you may hear the ice maker cycle multiple times when making one batch of ice.

How to Turn the Ice Maker On/Off

Display type	Model #	How to Turn the Ice Maker On/Off
Control Style A	PFE28P, PYE22P	Use the "Ice" button on the control. See Controls
Control Style B, C	PFH28, PFE28K, PFD28, DFE28, GFE28, GFD28, GFE26, GFS26, PYD22, PYE22K, DYE22K, HYE22, GYS22	Use the "Ice MAKER" button on the control. See Controls
Control Style D	GNE29, PWE23	Use the "Ice MAKER" button on the control. See Controls

Ice Bucket and Dispenser*

- Open the ice box door on inside of the left door.
- Pull up and out on the ice bucket in the left hand door to remove it from the compartment .
- To replace the ice bucket, set it on the guide brackets and push until the ice bucket seats properly.
- If bucket cannot be replaced, rotate the ice bucket fork 1/4 turn clockwise

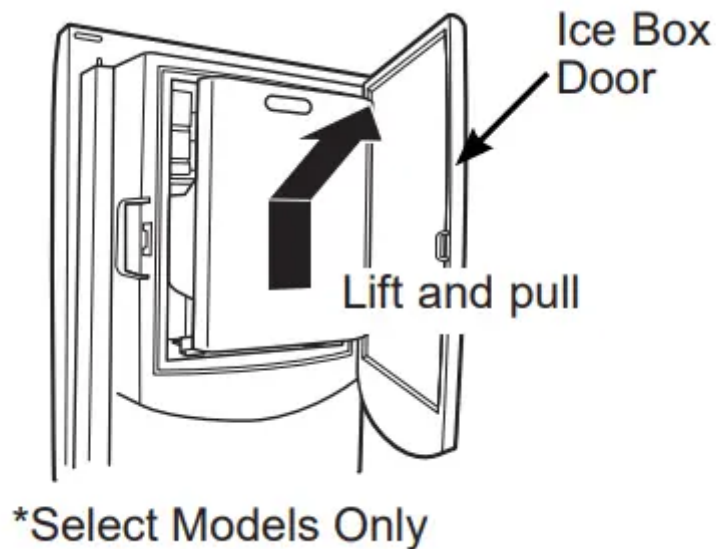

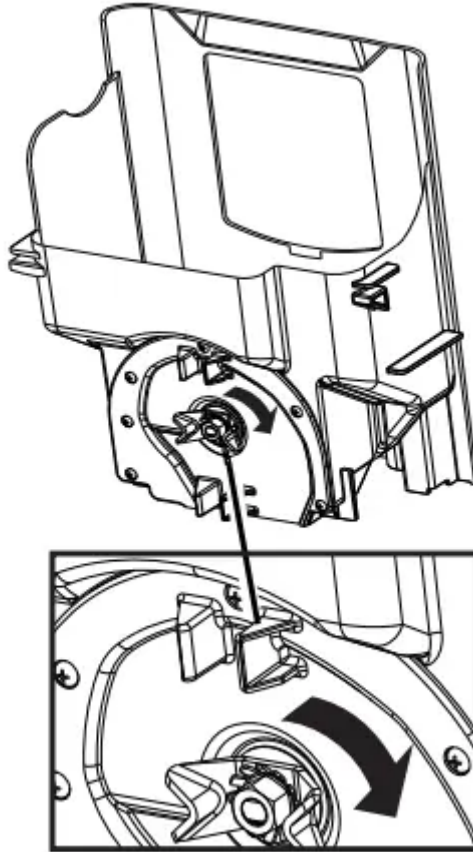

Ice Maker (Available on Non Dispense models, also available as IM Kit for some models): There is additional ice storage in the freezer compartment drawer.

- Open the freezer drawer
- The ice bucket is located on the left side of the upper basket.
- Pull the upper basket forward to remove the ice bucket.

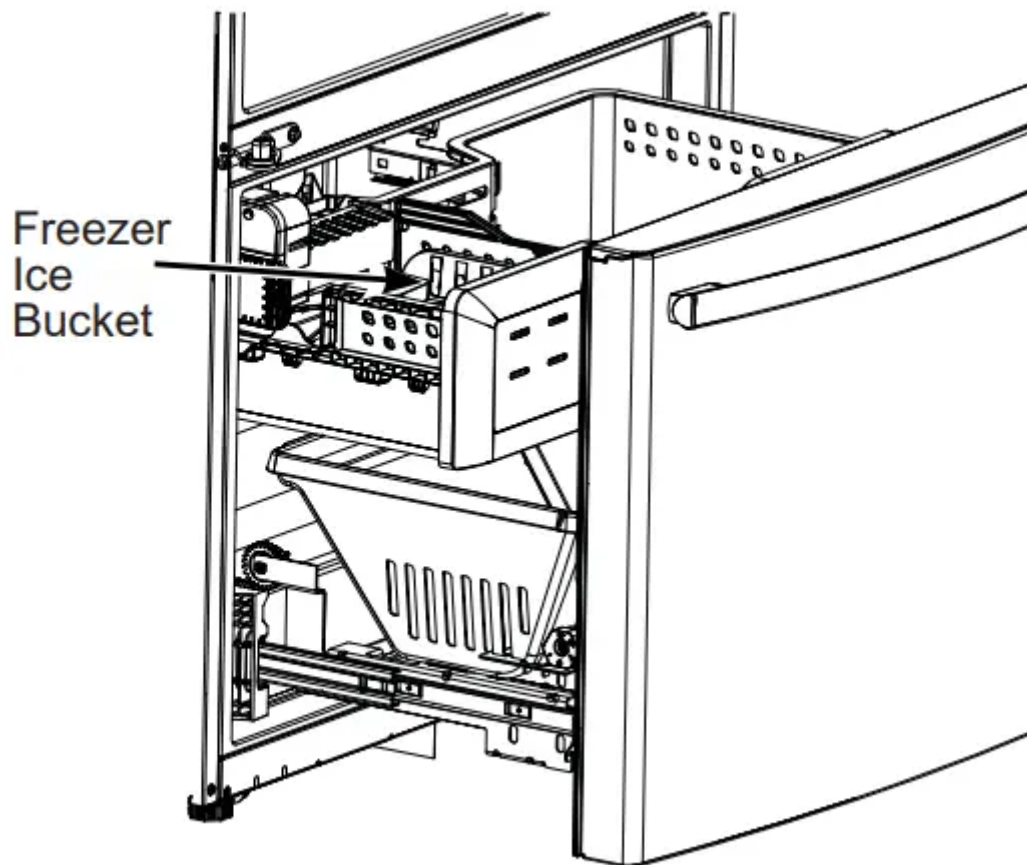

Care and Cleaning

Cleaning the Outside

Directions for Cleaning Outside Surfaces, Door Handles, and Trim

DO USE	DO NOT USE
Soft, clean cloth or sponge	Abrasive cloths, scrubbing sponges, scouring or steel wool pads
<p>Mild detergent mixed with warm water Approved stainless steel cleaners; Visit the GE Appliances parts store for approved stainless steel cleaners: GEAppliancesparts.com or call 877.959.8688</p> <p>Cleaners with oxalic acid such as Bar Keepers Friend Soft Cleanser™ can be used to remove surface rust, tarnish and small blemishes on stainless steel surfaces only</p>	<p>Abrasive powders or sprays</p> <p>Window Sprays or Ammonia</p> <p>Citrus or plant oil-based cleaners</p> <p>Acidic or vinegar-based cleaners</p> <p>Oven cleaners</p> <p>Cleaners containing acetone (propanone)</p> <p>Any cleaner with WARNING about plastic contact</p>

Cleaning the Inside

- To help prevent odors. leave an open box of baking soda in the refrigerator and freezer compartments.
- Unplug the refrigerator before cleaning.
- If this is not practical, wring excess moisture out of sponge or cloth when cleaning around switches. lights or controls.
- Use an appliance wax polish on the inside surface between the doors.
- Use warm water and baking soda solution—about a tablespoon (15 ml) of baking soda to a quart (1 liter) of water. This both cleans and neutralizes odors. Rinse and wipe dry.
- To clean the inside metal panel*, open the outer door using the Door in Door Latch. Clean the panel with a mild detergent and then wipe dry with a soft cloth. Do not use any stainless steel cleaner on the panel as it may damage the surrounding plastic.
- Do not clean glass shelves or covers with warm water when they are cold. Glass shelves and covers may break if exposed to sudden temperature changes or impact such as bumping or dropping. Tempered glass is designed to shatter into many small pieces if it breaks.

- Do not wash any plastic refrigerator parts in the dishwasher.

Behind the Refrigerator

- Be careful when moving the refrigerator away from the wall. All types of floor coverings can be damaged, particularly cushioned coverings and those with embossed surfaces.
- Raise the leveling legs located at the bottom front of the refrigerator.
- Pull the refrigerator straight out and return it to position by pushing it straight in. Moving the refrigerator in a side direction may result in damage to the floor covering or refrigerator.
- Lower the leveling legs until they touch the floor.
- When pushing the refrigerator back, make sure you don't roll over the power cord or water supply line.

Preparing for Vacation

For long vacations or absences, remove food and unplug the refrigerator. Clean the interior with a baking soda solution of one tablespoon (15 ml) of baking soda to one quart (1 liter) of water. Leave the doors open.

If the temperature can drop below freezing, have a qualified service technician drain the water supply system to prevent serious property damage due to flooding.

1. Turn refrigerator off or unplug the refrigerator.
2. Empty ice bucket
3. Turn water supply off

If you cut the water supply off, turn off the ice maker. Upon returning from vacation:

1. Replace the water filter.
2. Run 2 gallons (7.57 liters) of water through the cold water dispenser (about 5 minutes) to flush the system.

Preparing to Move

- Secure all loose items such as shelves and drawers by taping them securely in place to prevent damage.
- When using a hand truck to move the refrigerator, do not rest the front or back of the refrigerator against the hand truck. This could damage the refrigerator.
- Handle only from the sides of the refrigerator.
- Be sure the refrigerator stays in an upright position during moving.

Refrigerator Lights (LEDs)

Refrigerator Lights (LEDs)

- Appearance may vary by model.
- There is LED lighting in fresh food compartment and or the bottom of the fresh food doors to light the freezer compartment.”
- An authorized technician will need to replace the LED light.

Troubleshooting Tips

Normal operating sounds

Newer refrigerators sound different from older refrigerators. Modern refrigerators have more features and use newer technology

Do you hear what I hear? These sounds are normal.

- The new high efficiency compressor may run faster and longer than your old refrigerator and you may hear a high-pitched hum or pulsating sound while it is operating.
- You may hear a whooshing sound when the doors close. This is due to pressure equalizing within the refrigerator.
- After dispensing ice, a motor will close the ice chute to keep warm room air from entering the ice bucket, maintaining ice at a freezing temperature. The hum of the motor closing the ice chute is normal, shortly after dispensing ice.
- You may hear the fans spinning at high speeds. This happens when the refrigerator is first plugged in, when the doors are opened frequently or when a large amount of food is added to the refrigerator or freezer compartments. The fans are helping to maintain the correct temperatures.
- The fans change speeds in order to provide optimal cooling and energy savings.

CLICKS, POPS, CRACKS and SNAPS

- You may hear cracking or popping sounds when the refrigerator is first plugged in. This happens as the refrigerator cools to the correct temperature.
- The compressor may cause a clicking or chirping sound when attempting to restart (this could take up to 5 minutes)

- Expansion and contraction of cooling coils during and after defrost can cause a cracking or popping sound.
- On models with an icemaker, after an icemaking cycle, you may hear the ice cubes dropping into the ice bucket.
- After dispensing ice, a motor will close the ice chute to keep warm room air from entering the ice bucket, maintaining ice at a freezing temperature
- The flow of refrigerant through the freezer cooling coils may make a gurgling noise like boiling water.
- Water dropping on the defrost heater can cause a sizzling, popping or buzzing sound during the defrost cycle.
- A water dripping noise may occur during the defrost cycle as ice melts from the evaporator and flows into the drain pan.
- Closing the door may cause a gurgling sound due to pressure equalization.

START UP COOLING

- It can take up to 24 hours for the refrigerator and freezer temperature to match the display. During that time refrigerator and freezer door openings should be minimized.
- TIPS
 - Freezer cools first
 - Refrigerator compartment cools last, it may take several hours after the freezer
 - Turning off ice maker makes both fresh food and freezer food cool faster

Before you call for service...



Problem	Possible Causes	What to Do
Water filter indicated as installed incorrectly or a leak is present on cap control panel.	Water filter installed backward or is leaking.	Check for leak. If no leak is present remove filter/ bypass plug**, rotate 180° and reinstall.
“Warning Triangle” is lit Replace Filter/ Replace Water Filter is lit. Over Due light is lit	Water filter leaking or needs replacing Water filter backwards	Replace water filter, check for leak Remove filter, rotate 180° and reinstall
Dispenser Offs lit	Control A, B & C Wrong filter installed	Replace filter with proper filter Remove filter, rotate 180° and reinstall
Not filtering	Filter bypass installed Controls B & C	Install correct water filter
Reset Filter is lit	Water filter leaking or needs replacing	<ul style="list-style-type: none"> • Replace water filter. or install filter bypass **. • Press and hold Reset Filter for 3 seconds to reset (Control D only)
Water filter indicator light is not lit	This is normal. This light will turn orange to tell you that you need to replace the filter soon. The filter cartridge should be replaced when the replacement indicator light turns red.	See About the water filter for more information.
Handle is loose / handle has a gap	Handle needs adjusting	See Attach the Fresh Food handle and Attach the Freezer handle sections for detailed instructions.

Refrigerator beeping	This is the door alarm.	<ul style="list-style-type: none"> • Turn off or disable with door closed • If door open and alarm is sounding you can only snooze the alarm
Not cooling	The cooling system is off	See About Controls
Water has poor taste/ odor*	Water dispenser has not been used for a long time	Dispense water, until all water in system is replenished.
Water in glass is warm*	<ul style="list-style-type: none"> • Normal when refrigerator is first installed • Water dispenser has not been used for a long time • Water system has drained 	<p>Wait 24 hours for the refrigerator to completely cool down.</p> <p>Dispense water, until all water in system is replenished</p> <p>Allow several hours for replenished supply to chill</p>
Water dispenser does not work*	<ul style="list-style-type: none"> • Water supply line turned off or not connected • Water filter clogged or filter/ bypass plug not installed • Air may be trapped in the water system • Water in reservoir is frozen because the controls are set too cold 	<p>See Installing the Water Line</p> <p>Replace filter cartridge or remove filter and install bypass plug**</p> <p>Press the dispenser arm for at least 5 minutes.</p> <p>Set the refrigerator control to a warmer setting and wait 24 hours. If the water does not dispense after 24 hours, call for service</p>
Water spurting from dispenser*	Newly installed filter cartridge	Run water from the dispenser for 5 minutes (about 2 gallons)
No water or ice cube production*	<ul style="list-style-type: none"> • Supply line or shutoff valve is clogged • Water filter is clogged 	<p>Call a plumber</p> <p>Replace filter cartridge or remove filter and install bypass plug**</p>



	<ul style="list-style-type: none"> • Filter cartridge not properly installed • Ice maker is turned off 	<p>Remove and reinstall filter cartridge, being certain that it locks in place.</p> <p>Check that the ice maker is turned on. See About the Automatic Ice Maker</p>
Water is leaking from dispenser*	Air may be present in the water line system, causing water to drip after being dispense	Dispense water for at least 5 minutes to remove air from system
AUTO FILL under fill/ no fill*	<ul style="list-style-type: none"> • Not all containers work with AUTOFILL • Error message 	<p>Try different container</p> <p>See page 14. Clean sensor.</p>
AUTO FILL overfills*	Not all containers work with AUTO FILL	Try different container
Freezer cooling, fresh food not cooling	Normal, when refrigerator first plugged in or after extended power outage	Wait 24 hours for temperature in both compartments to reach selected temperatures.
Ice dispenser opens after closing	Normal	The ice dispenser door may open after closing freezer door to allow access
Low brewing flow rate	There may have been a dent at the bottom of K- Cup causing the pin to pierce the filter allowing coffee grounds clogging the bottom pin	Avoid using damaged/ dented K- Cup, and clean the lower needle before next brew
Low brewing flow rate/ water drips from inner door	Top needle of the brewer clogged	Unclog the top needle holes using a paper clip and rinse brewer. Rinse brewer after every use
Brewer is not detected or hot water leaking from top of the brewer	Incorrect assembly of brewer in the bracket	Make sure the Keurig Logo is in the front. Push brewer all the way in the brackets
Coffee dispensed with splash or bubble bursting	Blocked vent hole in the brewer	Make sure the vent hole at the bottom of the brewer is clear from food or any other contamination

Beverage quality not as expected	You may be using non-standard or out dated K - Cups	Recommended using official Keurig K - Cups that are not past expiration and have not been damaged
Liquid drips from the brewer after brewer cycle is completed and the brewer is removed from the bracket	It is not possible for liquids to be retained by the brewer and drip when it is removed	Use a cloth or container to capture the drips when brewer is removed
Delay when using Keurig K - cup Pod dispenser	To ensure a quality beverage is delivered, a short delay is required to ensure the refrigerator is operating correctly	Ensuring consistent, quality operation requires the refrigerator to delay dispense for a short period of time
After brewing, my powdered beverage is not fully cleared from the used pod	Depending on size selected, the powder may not dissolve fully. Some powdered beverages develop into 'clumps' when left sitting for some time	Shake the powdered pods before brewing to break up these clumps and allow better clearing. For powdered beverage with no filter, use the Cocoa cycle selection
Brewer lid is difficult to close	K-cup is not fully seated	Press K-cup all the way down into the brewer prior to closing the lid. Lower needle must puncture K-cup before closing the brewer lid
Brewer leaks during the brew cycle	Trouble in closing brewer lid or damaged K-cup	Press K-cup all the way down into the brewer prior to closing the lid. Lower needle must puncture K-cup before closing the brewer lid. Recommend using official Keurig K-cups that have not been damaged and have a good seal between the top cover and plastic bottom

Truth or Myth



Truth or Myth?	Answer	Explanation
The refrigerator water filter may require replacement prior to six months	TRUE	The water filter indicator will indicate the need to replace the water filter every six months or 170 gallons of water dispensed (select models only). Water quality varies from city to city. If water flow from the dispenser slows, or ice production decreases, the water filter should be replaced, even though the filter indicator may not indicate the need for replacement.
The automatic ice maker in my refrigerator will produce ice when the refrigerator is plugged into a power receptacle.	MYTH	The refrigerator must be connected to water, and the ice maker must be turned on. Make sure the ice maker is turned on, only after the water line is connected and water is turned on. The ice maker can be turned on/ off from the controls and ensure the ice maker is on, as indicated on the refrigerator control panel. See About the Automatic Ice Maker.
After the refrigerator has been plugged in and connected to water, I will immediately have unlimited chilled water available from the water dispenser.	MYTH	The water dispenser tank located inside the refrigerator stores water for dispensing. The water in this tank requires 24 hours to chill after installation. High usage conditions will not allow time for the water to chill.
After water dispenses, a few drops of water are normal.	TRUE	A few drops of water may fall from the dispenser, after the dispenser paddle has been released. To minimize the drops, remove the glass slowly from the dispenser.
I will never see frost inside the freezer compartment.	MYTH	Frost inside the freezer typically indicates that the door is not properly sealed, or has been left open. If frost is found, clear the frost using a plastic spatula and towel. then check to ensure that no food packages or containers are preventing the freezer door from closing. Check the refrigerator control panel to ensure the door alarm is on.
When the refrigerator is installed, or after replacing the water filter. I must dispense water for five minutes.	TRUE	A newly installed refrigerator or water filter contains air in the water lines. Press the dispenser paddle and dispense cold water for at least 5 minutes to remove air from the waterline and flush the filter.



To fill the ice bucket to the maximum capacity. should dispense 12 and 18 hours after installation.	TRUE	Dispensing 3-4 cubes 12 hours and 18 hours after installation, allows ice to disperse within the ice bucket, which in turns calls on the ice maker to produce additional ice. Normal ice production = 100 cubes in 24 hours.
I can use the water filter bypass plug to determine if the filter requires replacement.	TRUE	Decrease in flow from the water dispenser. or decreased ice production, may indicate the need to replace the water filter. Install the water filter bypass plug (provided with the refrigerator on some models*) and check flow from the dispenser. If water flow returns to normal with the bypass plug in place, replace the water filter.
The top of the refrigerator doors will always be aligned.	MYTH	Several things can affect the fresh food door alignment, including the floor the refrigerator is installed on and loading of doors. If the top of the fresh food doors are not aligned, use a 1/4" allen wrench to adjust the right/left hand door. The adjustment screw is located on the bottom right or left hand side of the door, open the freezer door to access the screw.
Refrigerator door handles can be easily tightened.	TRUE	If door handles are loose or have a gap. the handle can be adjusted using a 1/8" allen wrench. on set screws located on the ends of the handles.
There may be odor and taste problems with your ice.	TRUE	After starting the ice maker, throw away 24 hours of ice production to avoid odor and taste problems.
I can make fine adjustments to the fresh food doors to align them.	TRUE	If the fresh food doors are not aligned, use a 1/4" Allen wrench to adjust the right hand door. The adjustment screw is located on the bottom of the right tleft hand door. Open the freezer door to access.
Door handles should always be removed for installation.	MYTH	If the doors must be removed do not remove the handles. or if the refrigerator will fit easily through the passage way opening. Adjust handles that are loose or have a gap, by adjusting 1/8" set screws on either end of handles.
Door removal is always required for installation.	MYTH	Check chart on reverse side of this instruction. Doors should only be removed when necessary to prevent damage from passage way or access to final location.



Refrigerator doors that won't close after installation, can be adjusted to close properly.	TRUE	Door mechanism works best if installed at 90°+. if installed at 180°. remove the door from the mid hinge, and swing the door 180° before reinstalling. See Reinstalling the Refrigerator Doors.
There is an adjustment to rear wheels.	MYTH	Front leveling legs are adjustable and should be used to balance the refrigerator. Leveling legs are used to make initial fresh food door adjustment.
Check for leaks after all water connections are made.	TRUE	While purging the air from the water system. check all water line connections for leaks. Check the connection to the household water supply at back of refrigerator and door water line connect.
Any packaging residue can be cleaned off the refrigerator using any cleaner.	MYTH	Do not use wax. polish. bleach. or other products containing chlorine Stainless Steel panels. door handles and trim. Check this instruction under "Cleaning the Outside" for full details.

Warning

This content is compiled from multiple sources and is provided for reference purposes only. It may not be complete or fully applicable to all situations. If you are unable to resolve your issue, please contact the product manufacturer or an authorized service provider for official support.

