

Operating Instructions

About the controls on your Zoneline.



TEMP CONTROL



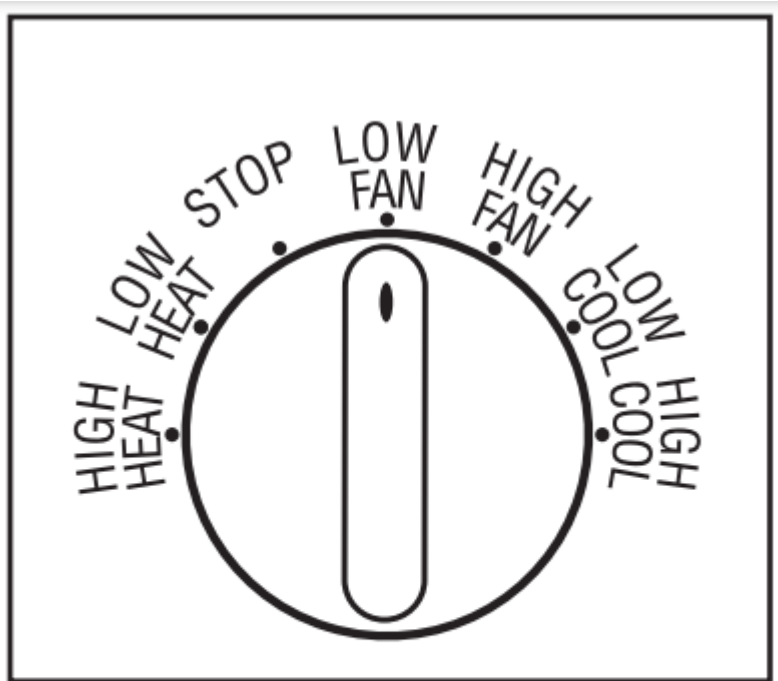

MODE CONTROL

2

<p>1. Temp Control</p>	<p>The temp control is used to maintain the room temperature. The compressor will cycle on and off to keep the room at the same comfort level. When you turn the knob to COOLER (blue), the indoor air will become cooler. Turn the knob to WARMER (red) and the indoor air will become warmer.</p> <p>3800 Series only When the outdoor temperature is lower than 20°F, heat is provided by the electric heater in the air conditioner instead of by the heat pump.</p>
<p>2. Mode Control</p>	<p>HIGH COOL and LOW COOL provide cooling with different fan speeds.</p> <p>HIGH HEAT and LOW HEAT provide heating with different fan speeds.</p> <p>LOW FAN or HIGH FAN provides air circulation and filtering without cooling or heating.</p>

About Your Heat Pump (3800 Series only)

Heat pumps can save money by removing heat from the outside air—even when the outside temperature is below freezing—and releasing that heat indoors.

To get the best performance from your heat pump, don't change the room thermostat very often. Raising the heat setting 2–3 degrees will cause the Zoneline to use its electric heating elements in order to reach the new temperature setting quickly.

There is a three-minute minimum compressor run time at any setting to prevent short cycling.

The indoor fan motor starts before the compressor and stops after the compressor cycles off.

The electric heating elements use much more electricity than heat pumps and cost more to operate.

Quick Heat Recovery

Activates each time the thermostat is switched from STOP or a COOL mode to a HEAT mode. Electric heaters are energized until the thermostat set point is reached. On heat pump models, the heat pump operation will resume at the next call for heat.

Other features of your Zoneline

Ventilation Control

The ventilation control lever is located at the upper left side of the Zoneline unit, behind the room cabinet.

When set at the closed position, only the air inside the room is circulated and filtered.

When set at the open position, some outdoor air will be drawn into the room. This will reduce the heating or cooling efficiency.

Energy Tip: Keep the vent control at the closed position. The room air will be filtered and circulated.

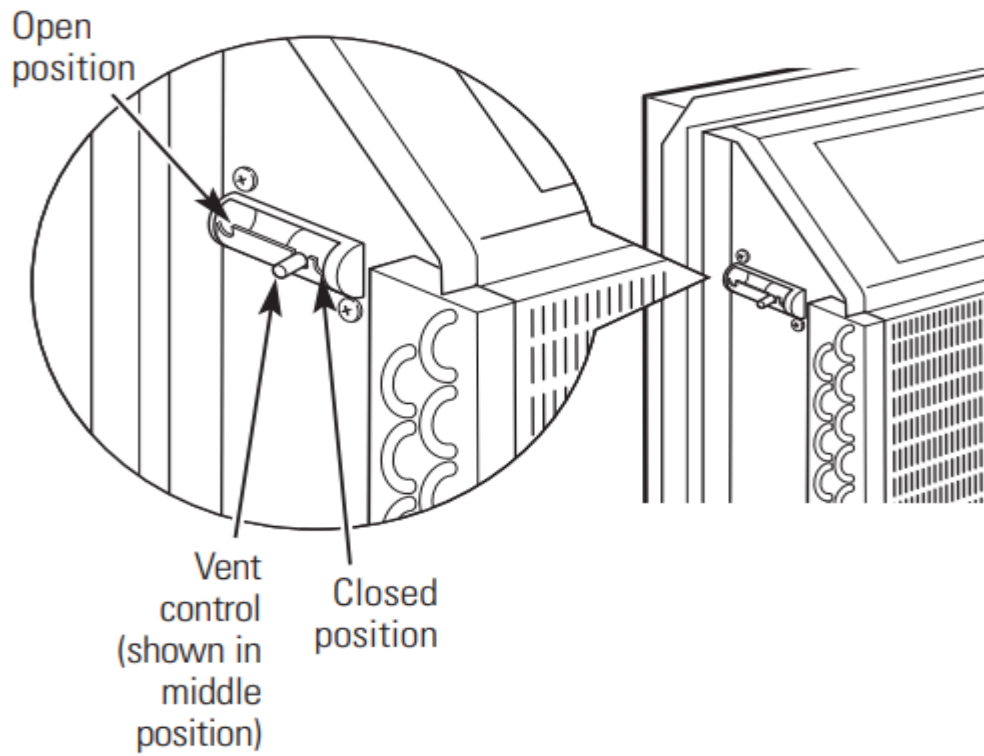

To Remove the Room Cabinet

Additional controls are located behind the room cabinet.

To remove: Pull out at the bottom to release it from the tabs (1). Then lift up (2).

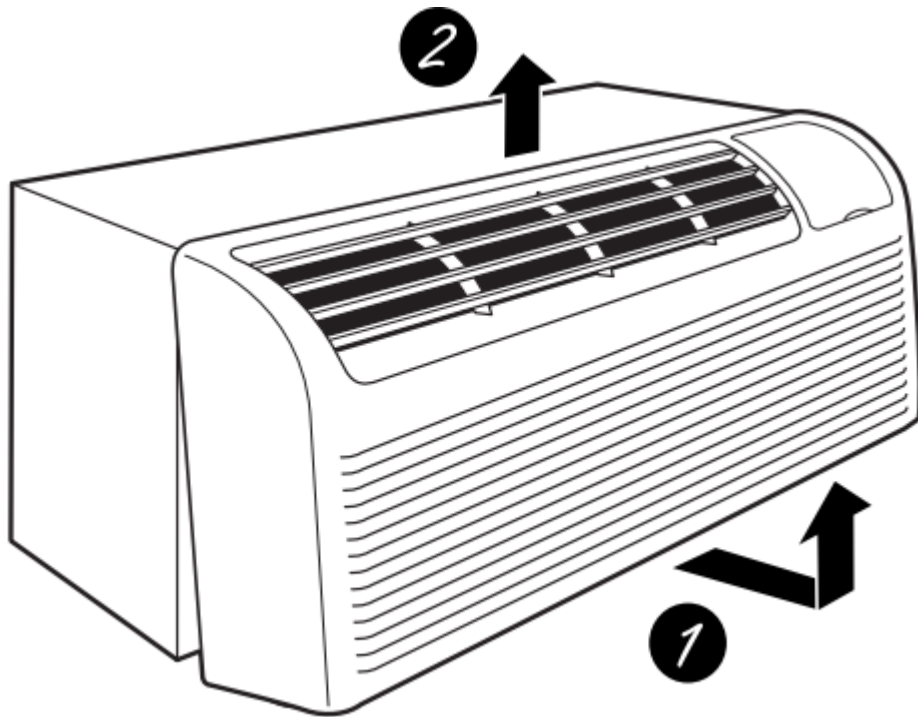

To replace: Place the tabs over the top rail (1). Push inward at the bottom until it snaps into place (2).

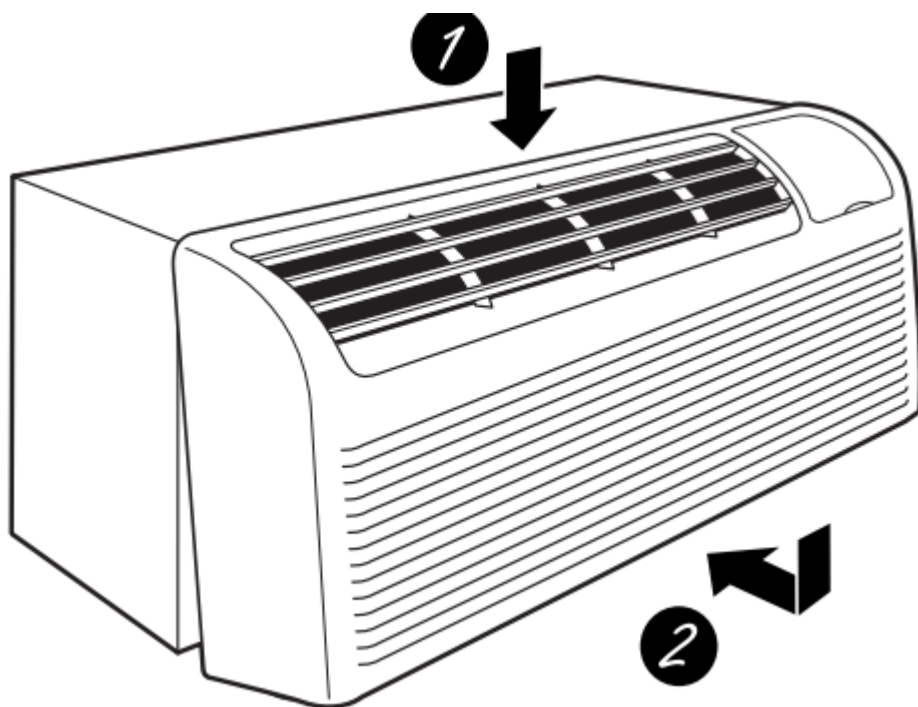

Air Direction

To adjust the air direction, remove the room cabinet. Remove the 7 louver screws that hold the louver insert in place. Flip the louver insert 180°, replace the screws and the room cabinet.

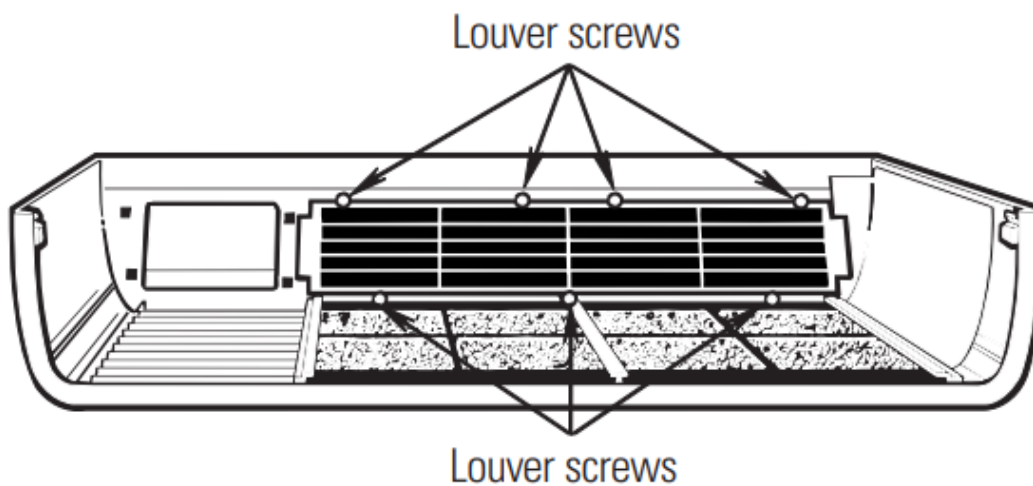

Remove the room cabinet and flip the louver insert to change the air direction.

All Electric Heat

This electric heat option functions only on the 3800 Series models. When this switch is enabled (UP), heat pump operation is locked out, causing the unit to provide only electric resistance heat.

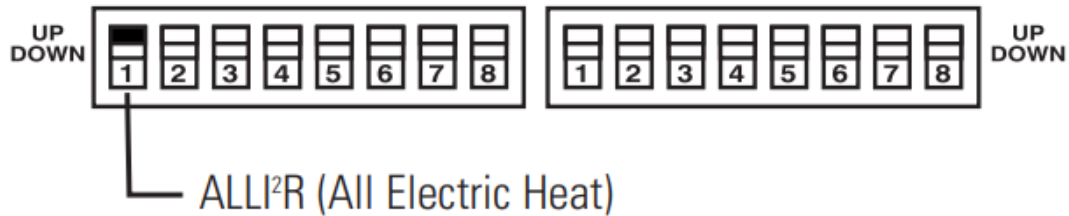

Cooling—Smart Fan

When this switch is enabled (UP), it allows the indoor fan to cycle on/off with the compressor. When this switch is disabled (DOWN), it allows the indoor fan to run continuously

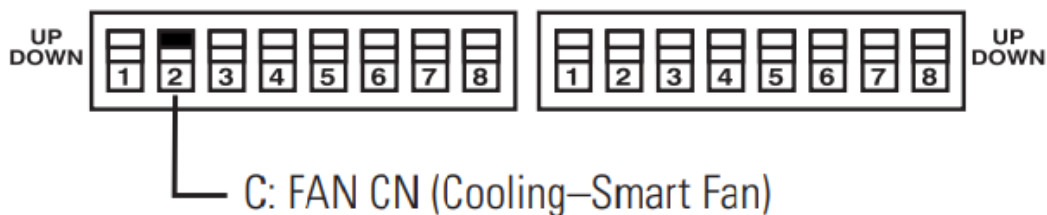

Heating—Smart Fan

When this switch is enabled (UP), it allows the indoor fan to run continuously. When this switch is disabled (DOWN), it allows the indoor fan to cycle on/off with the heat pump or heater operation.

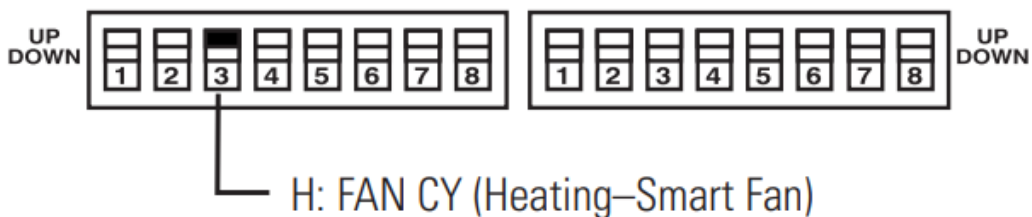

Auxiliary controls on your Zoneline.

Remote Thermostat—Class 2

When this switch is enabled (UP), it allows the unit to operate with a Class 2 Remote Control Wall Thermostat. The unit controls are disabled.

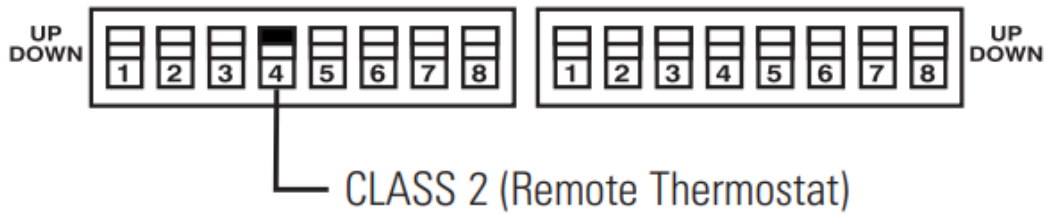

Load Shedding (Central Desk Control)

This feature is active only if the unit is in CDC mode. When this switch is enabled (UP), the indoor fan can be turned ON or OFF with the unit controls.

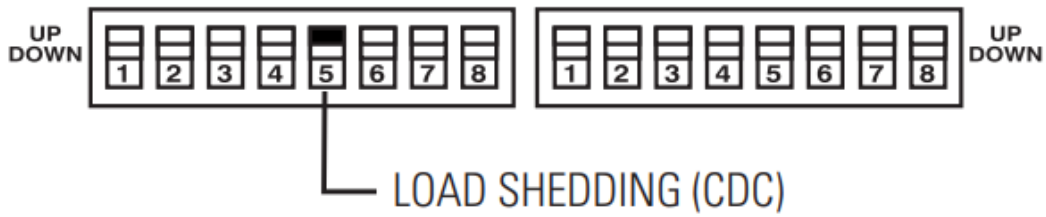

Freeze Sentinel

When this switch is enabled (UP), it turns OFF the freeze sentinel protection feature. With the switch disabled (DOWN), the freeze sentinel is activated, which automatically provides heat without user interface. This helps to prevent plumbing damage by turning the heater and indoor fan ON at 41°F and OFF at 46°F.



Constant ON Fan

When this switch is enabled (UP), it allows the indoor fan to run continuously, at high speed, even if the unit is in the STOP position.

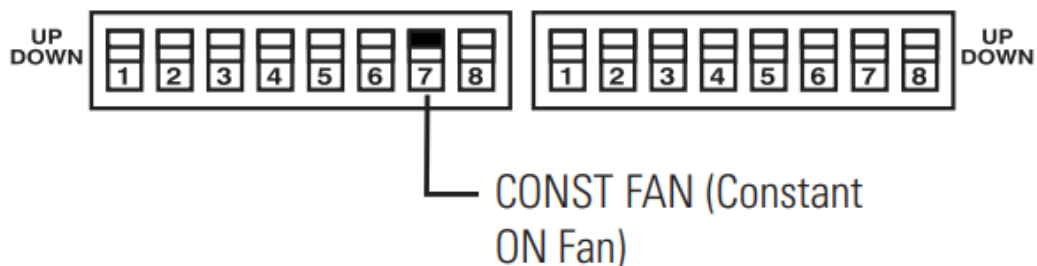

Temperature Limiting

Temperature limiting can reduce energy costs by limiting the lowest temperature that can be set for cooling and the highest temperature that can be set for heating.

Temperature limiting is controlled by the second six auxiliary switches.

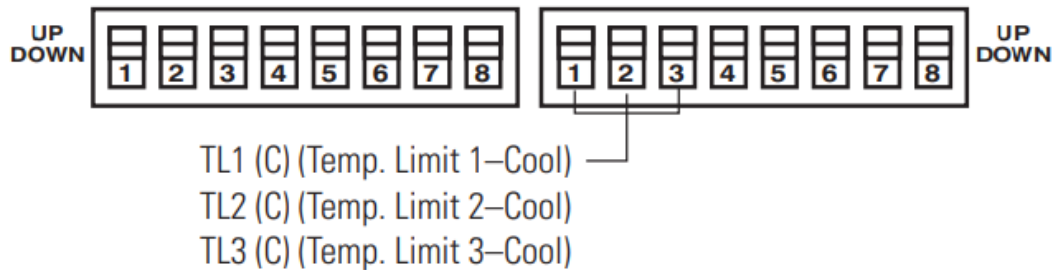

Temperature limiting during COOL mode (all temperatures shown in °F)			
UP	DOWN	Minimum	Maximum
NONE	1, 2, 3	60°	85°
1	2, 3	64°	85°
1, 2	3	66°	85°
2	1, 3	68°	85°
2, 3	1	70°	85°
1, 2, 3	NONE	72°	85°
1, 3	2	74°	85°
3	1, 2	76°	85°

The first three switches are used to select the cooling limits, and the remaining three switches are used to control the heating limits. This feature is not available with the Remote Thermostat—Class 2.

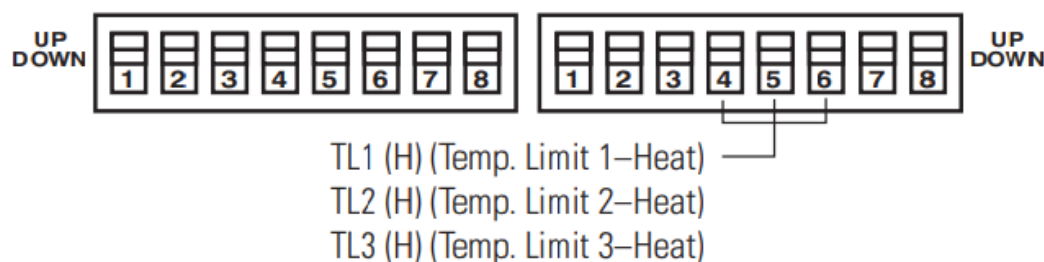

Temperature limiting during HEAT mode (all temperatures shown in °F)			
UP	DOWN	Minimum	Maximum
NONE	4, 5, 6	60°	85°
4	5, 6	60°	80°
4, 5	6	60°	78°
5	4, 6	60°	76°
5, 6	4	60°	74°
4, 5, 6	NONE	60°	72°
4, 6	5	60°	70°
6	4, 5	60°	65°

Heat Sentinel

When this switch is enabled (UP), it turns ON the heat sentinel protection feature. With the switch disabled (DOWN), the heat sentinel is deactivated. This feature automatically provides cooling without user interface. This helps to prevent an excessively hot room by turning the air conditioner ON at 85°F and OFF at 80°F.



Heat Boost (AZ3800 only)

When this switch is enabled (UP) and outdoor temperatures are between 20°F and 46°F, heat pump only operation is locked out. This setting is used to provide supplementary heat to the heat pump operation in conditions where the heat pump only operation is not sufficient to maintain a consistent, comfortable room temperature.

NOTE: This is an auxiliary switch for AZ2800 models and must remain in the (DOWN) position

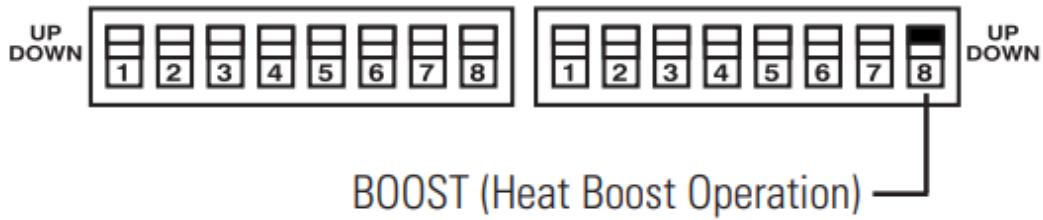

Auxiliary controls on your Zoneline.

Auxiliary Controls—Terminal Connections

The auxiliary controls are located behind the room cabinet beneath the access cover.

1. Remove the room cabinet. See the To Remove the Room Cabinet section.
2. Remove the screw from the access cover.
3. To make wiring connections, insert the wires into the bottom of the terminals and tighten screws securely.
4. After all desired connections have been made, replace the access cover and room cabinet.

The owner is responsible for making all connections and setting the appropriate dip switches.

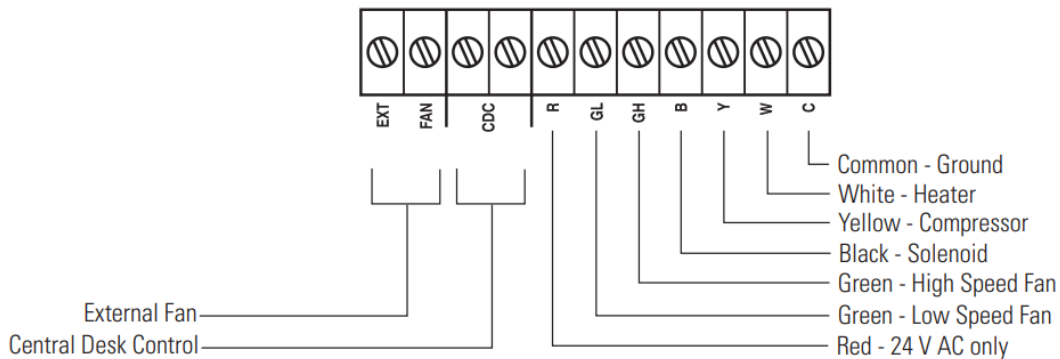

External Fan (Obtained locally)

When connected, an auxiliary or external fan can be controlled with the indoor fan motor on the Zoneline. Connections provide 24 V AC to energize a remote relay, turning on the external fan.



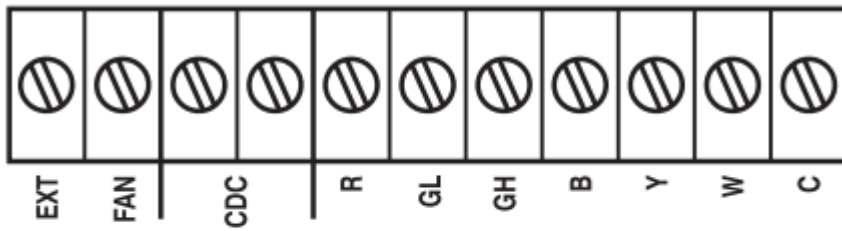

Central Desk Control

When connected, the unit can be turned ON or OFF with a switch located at the Central Control Panel. A separate wire pair must be run from each separate controlling switch to each individual Zoneline.

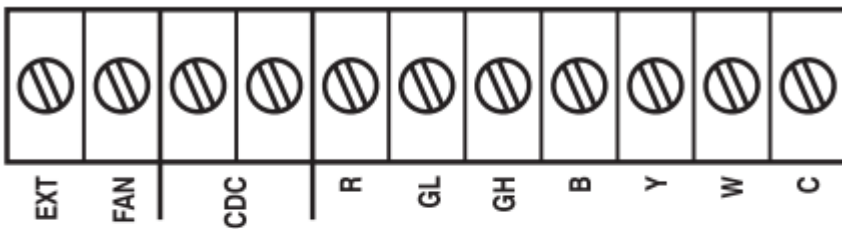

Remote Thermostat

When connected, the unit will be controlled by a remote thermostat.



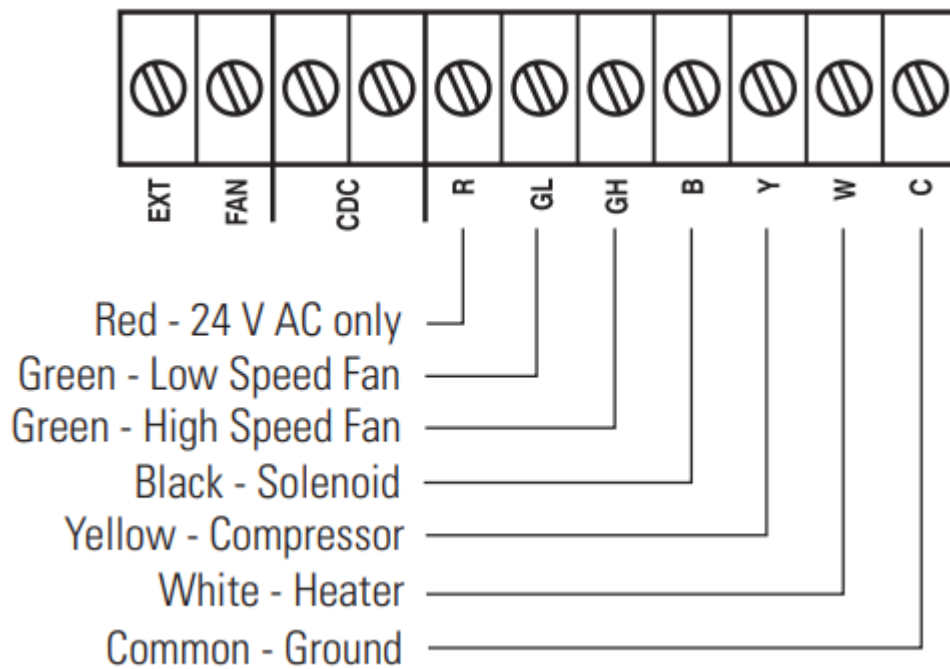

Care and Cleaning

Room Cabinet and Case

Turn the Zonline off and disconnect the power supply.

To clean, use water and a mild detergent. Do not use bleach or abrasives. Some commercial cleaners may damage the plastic parts.

Outdoor Coils

The coils on the outdoor side of the Zonline should be checked regularly. If they are clogged with dirt or soot, they may be professionally steam cleaned, a service available through your GE service outlet. You will need to remove the unit to inspect the coils because the dirt buildup occurs on the inside.

Clean the outside coils regularly

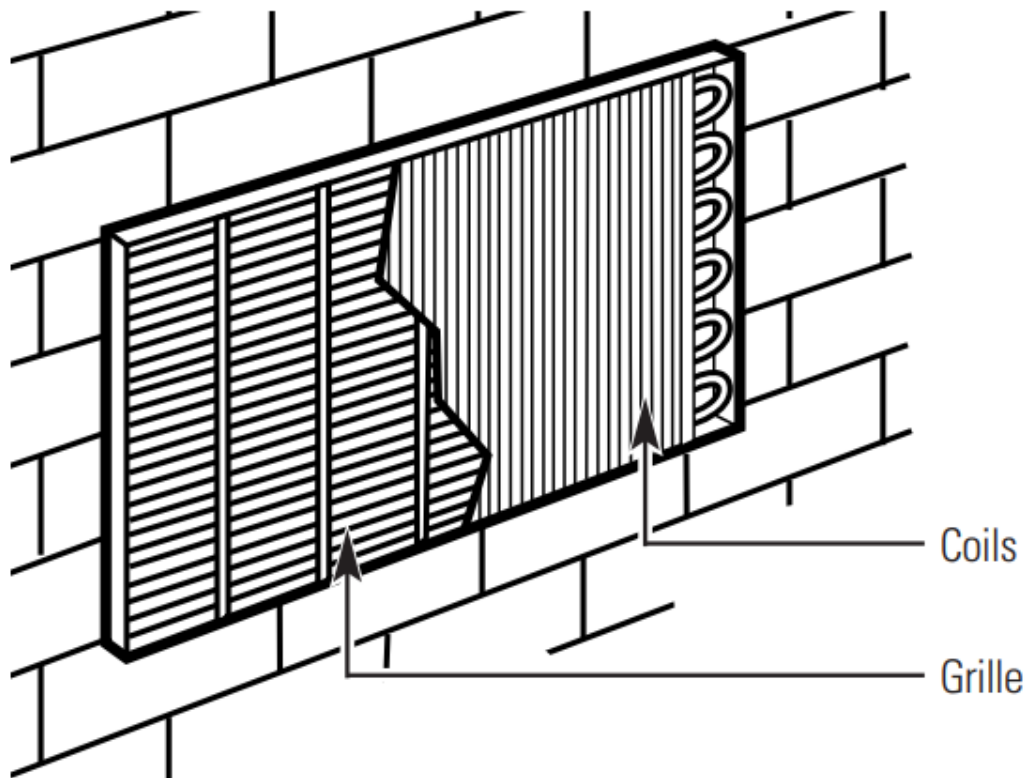

Base Pan

In some installations, dirt or other debris may be blown into the unit from the outside and settle in the base pan (the bottom of the unit).

In some areas of the United States, a “gel-like” or “slime-like” substance may be seen in the base pan. Check it periodically and clean, if necessary

Ventilation Filter

If the vent door is open, clean the vent filter twice a year or as required.

Turn the Zoneline off before cleaning

To remove the vent filter:

- Remove the room cabinet. See the To Remove the Room Cabinet section.
- Remove the four screws securing the unit flanges to the case.
- Slide the unit from the wall case.
- Grasp the vent filter tab and pull the filter out by sliding it to the right.

To clean the vent filter:

- Run water through the filter from the back side.
- Dry thoroughly before replacing

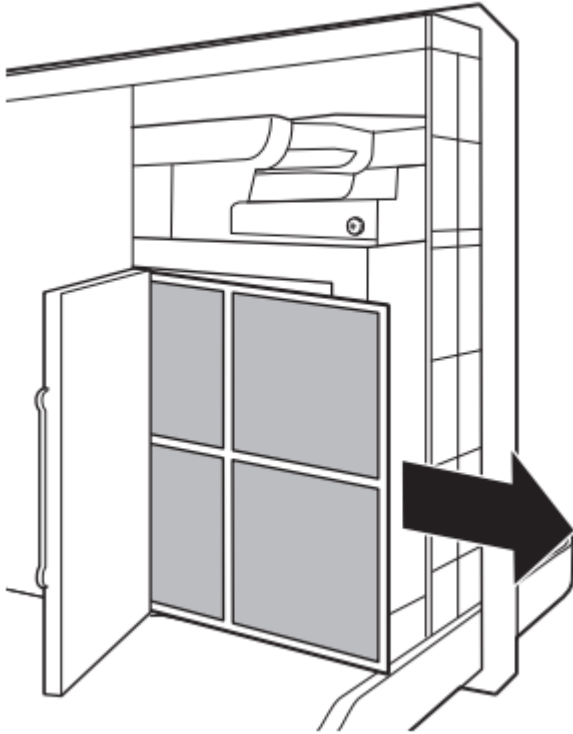

To maintain optimum performance, clean the filters at least every 30 days.

Air Filters

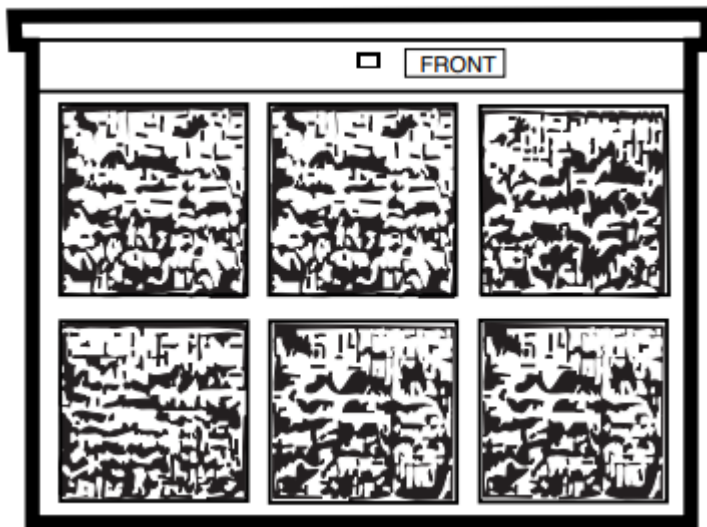

Dirty filter—Needs cleaning

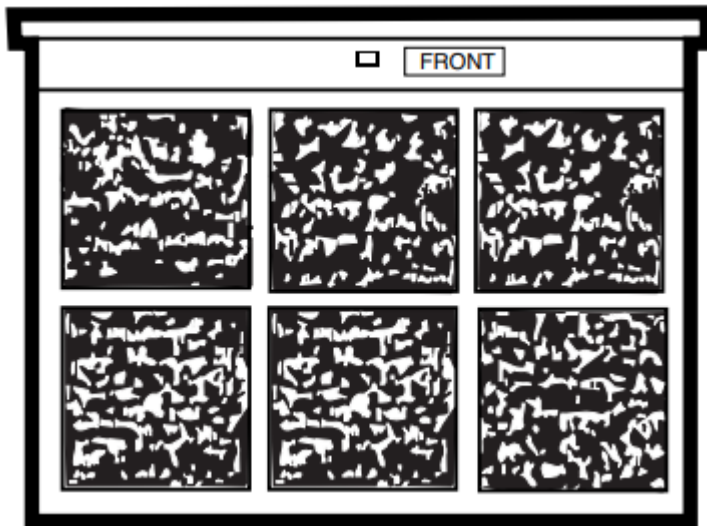

Clogged filter—Greatly reduces cooling, heating and airflow.

Turn the Zoneline off before cleaning.

The most important thing you can do to maintain the Zoneline is to clean the filter at least every 30 days. Clogged filters reduce cooling, heating and air flow.

Keeping these filters clean will:

- Decrease cost of operation.
- Save energy.
- Prevent clogged heat exchanger coils.
- Reduce the risk of premature component failure.

To clean the air filters:

- Vacuum off the heavy soil.
- Run water through the filters from the back side.
- Dry thoroughly before replacing.

To remove the air filters:

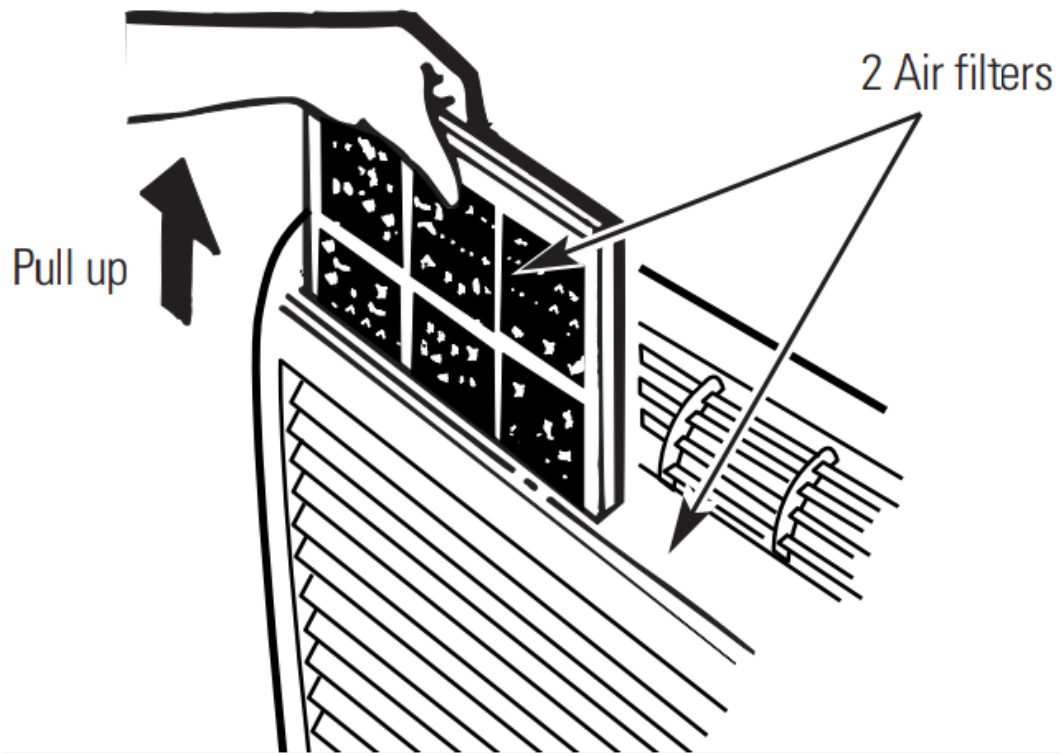

To replace the air filters:

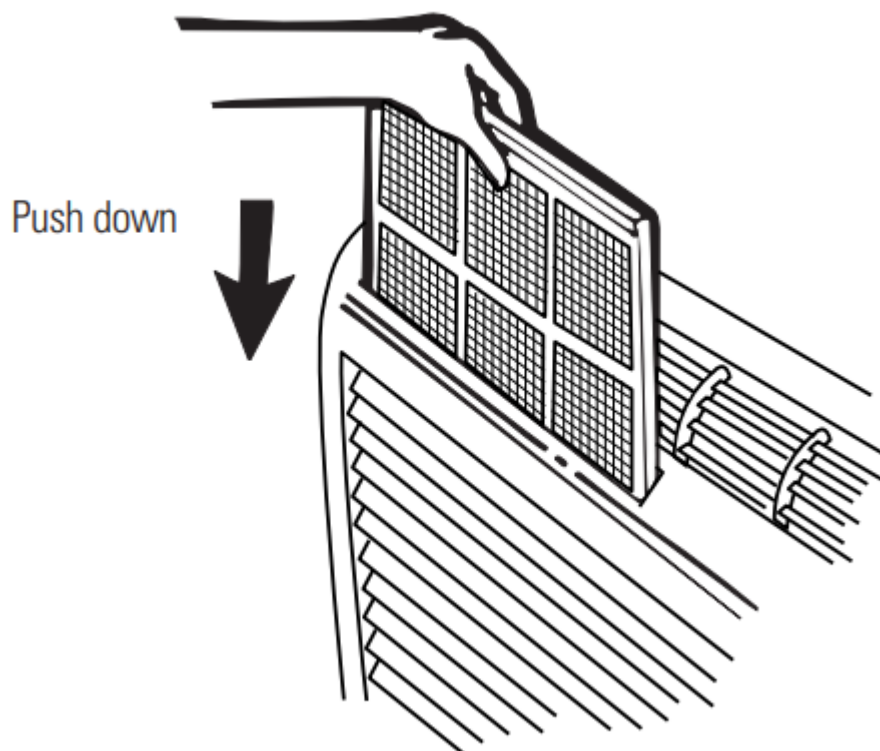

Operating without the filters in place or with damaged filters will allow dirt and dust to reach the indoor coil and reduce the cooling, heating, airflow and efficiency of the unit.

Replacement filters are available from your salesperson, GE dealer, GE Service and Parts Center or authorized Customer Care® servicers.



Troubleshooting Tips

Problem	Possible Causes	What To Do
Zoneline does not start	The unit is unplugged	<ul style="list-style-type: none"> • Make sure the Zoneline plug is pushed completely into the outlet.
	The power cord is not firmly attached.	<ul style="list-style-type: none"> • Remove the room cabinet and make sure that the yellow connector on the end of the power cord is firmly engaged
	The fuse is blown/ circuit breaker is tripped.	<ul style="list-style-type: none"> • Check the house fuse/circuit breaker box and replace the fuse or reset the breaker
	The unit is waiting for the compressor overload protector to reset.	<ul style="list-style-type: none"> • This is normal. The Zoneline will start again after it resets.
	Power failure.	<ul style="list-style-type: none"> • If power failure occurs, set the mode control to STOP. When power is restored, set the mode control to the desired setting. • There is a protective time delay (up to 3 minutes) to prevent tripping of the compressor overload. For this reason, the unit may not start normal heating or cooling for 3 minutes after it is turned back on.
	The current interrupter device is tripped.	<ul style="list-style-type: none"> • Press the RESET button located on the power cord plug or the box near the plug • If the RESET button will not stay engaged, discontinue use of the Zoneline and contact a qualified service technician.
Zoneline does not cool or heat as it should	Indoor airflow is restricted.	<p>Make sure there are no curtains, blinds or furniture blocking the front of the Zoneline.</p>
	Outdoor airflow is restricted or recirculated.	<ul style="list-style-type: none"> • Make sure the rear grille is not restricted. This can cause the unit to cycle off due to the compressor overload protector.



		<ul style="list-style-type: none"> • Outdoor grille must have a minimum of 65% free area Non-GE grilles may be too restrictive for proper performance. Consult your salesperson for assistance.
	The temp control may not be set properly	<ul style="list-style-type: none"> • Turn the control to a lower or higher setting
	The air filter is dirty	<ul style="list-style-type: none"> • Clean the filter at least every 30 days. See the Operating Instructions section.
	The room may have been hot or cold.	<ul style="list-style-type: none"> • When the Zoneline is first turned on you need to allow time for the room to cool down or warm up.
	Outdoor air is entering the room.	<ul style="list-style-type: none"> • Set the vent control to the closed position.
Burning odor at the start of heating operation	Dust is on the surface of the heating element.	<ul style="list-style-type: none"> • This can cause a “burning” odor at the beginning of the heating operation. This odor should quickly fade
The air is not always cool or hot during operation	The heat pump is not producing hot air	<ul style="list-style-type: none"> • This is normal. The heat pump will produce warm air but not as hot as air produced when the higher-cost electric heat is used.
	The fan switches may be set at continuous fan.	<ul style="list-style-type: none"> • This causes the fan to blow room-temperature air even when the compressor or heater cycles off. The continuous air movement provides better overall temperature control in the cool mode. • There is one switch for cooling and one switch for heating
The air does not feel warm enough during heating operation	The heat pump alone produces air that feels cooler than desired.	<ul style="list-style-type: none"> • Use the Electric Heat Option. This turns off the heat pump and warms with electric heat only
The unit is not blowing out air	The fan dip switch may be set to CYCLE.	<ul style="list-style-type: none"> • See the Auxiliary Controls section.



The electric heating feature does not work	The power cord is not firmly attached	<ul style="list-style-type: none">• Remove the room cabinet and make sure that the yellow connector on the end of the power cord is firmly engaged.
--	---------------------------------------	---

Warning

This content is compiled from multiple sources and is provided for reference purposes only. It may not be complete or fully applicable to all situations. If you are unable to resolve your issue, please contact the product manufacturer or an authorized service provider for official support.

