

General and important labels

Important labels

Read the following labels before using this watercraft. If have any questions, consult a Yamaha dealer.

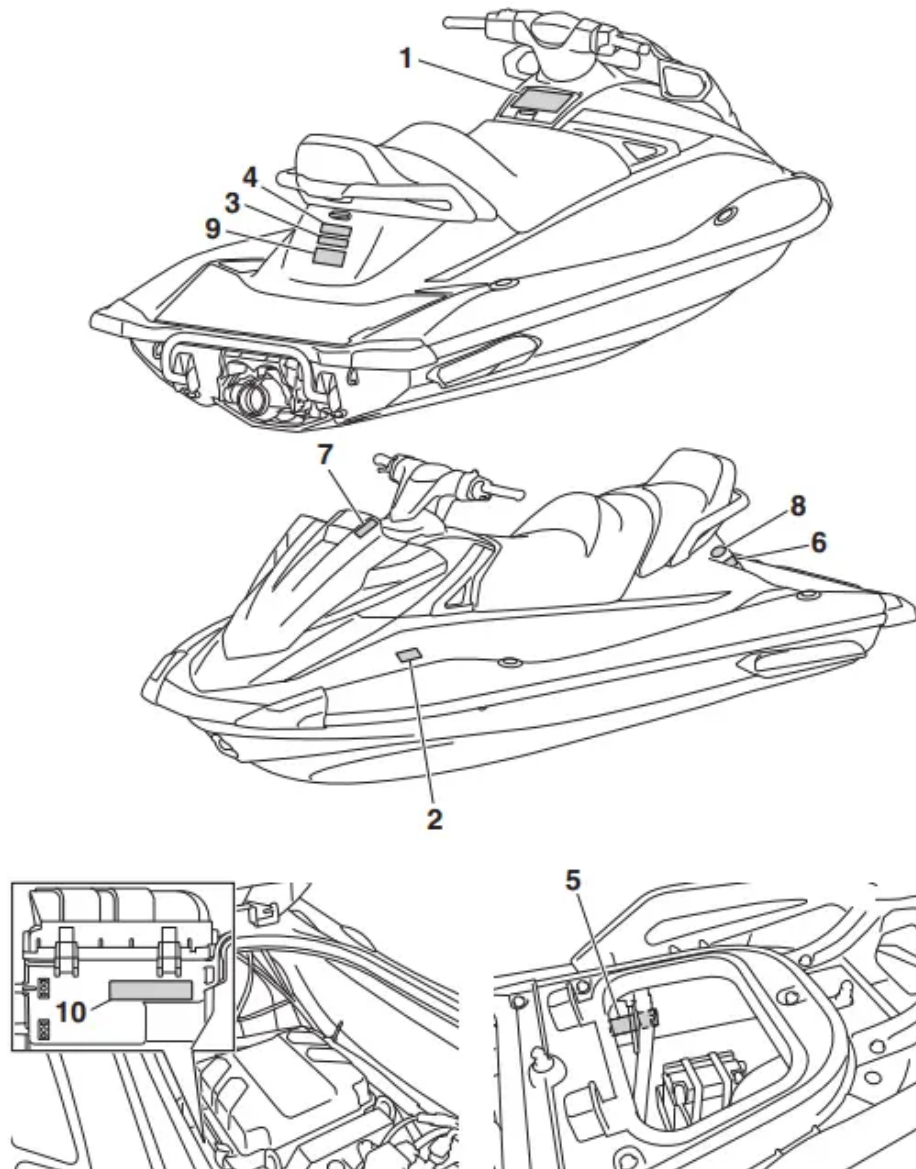

Description

Watercraft glossary

- Trolling speed: “Trolling” is the lowest maneuvering speed. You are applying little or no throttle. The watercraft is down in the water, and there is no wake.
- Sub-planing speed: “Sub-planing” is a medium speed. The bow of the watercraft is slightly up from the water surface, but you are still traveling through the water. There is a wake.
- Planing speed: “Planing” is a faster speed. The watercraft is more level and is skimming on top of the water. There is a wake.
- Bow: The front end of the watercraft.
- Stern: The rear end of the watercraft.
- Starboard: The right side of the watercraft when facing forward.
- Port: The left side of the watercraft when facing forward.
- Bilge water: Water that has collected in the engine compartment.
- Yamaha Engine Management System (YEMS): YEMS is an integrated, computerized management system that controls and adjusts ignition timing, fuel injection, engine diagnostics, and the off-throttle steering (OTS) system.
- Reverse with Intuitive Deceleration Electronics (RiDE): RiDE is an electronic system that controls the reverse, neutral, and deceleration operations of the watercraft.

Location of main components

Exterior

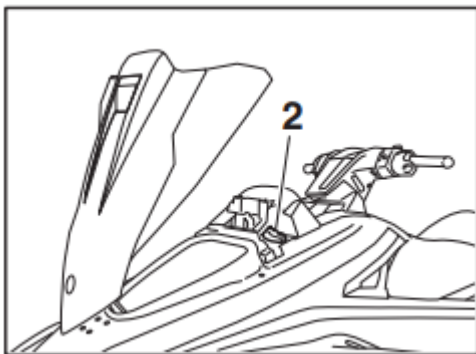

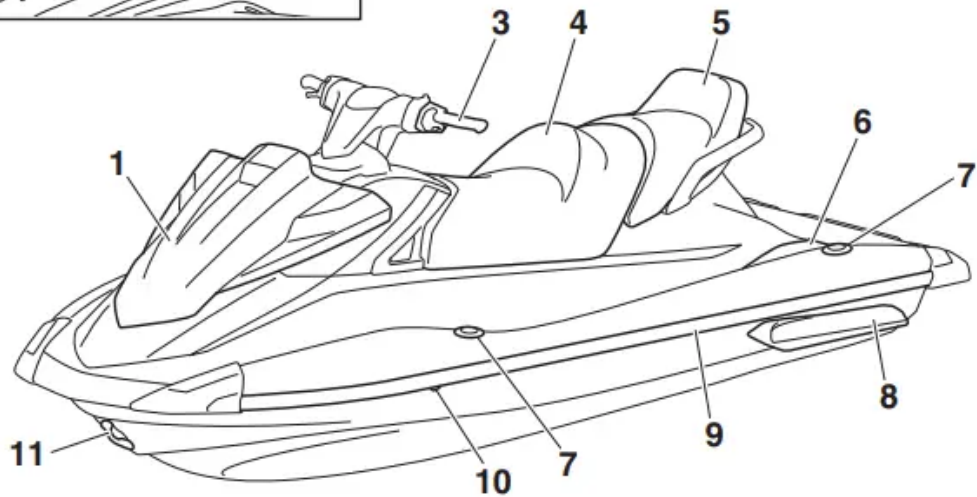
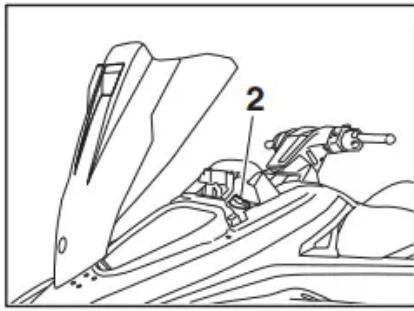

1. Boarding platform
2. Cleat (page 51)
3. Handgrip (page 50)
4. Stern eye (page 51)
5. Stern drain plug (page 60)
6. Reverse gate (VX / VX Deluxe / VX Cruiser / VX Limited) (page 37)
7. Jet thrust nozzle
8. Ride plate
9. Reboarding step (VX / VX Deluxe / VX Cruiser / VX Limited) (page 50)
10. Speed sensor
11. Intake grate

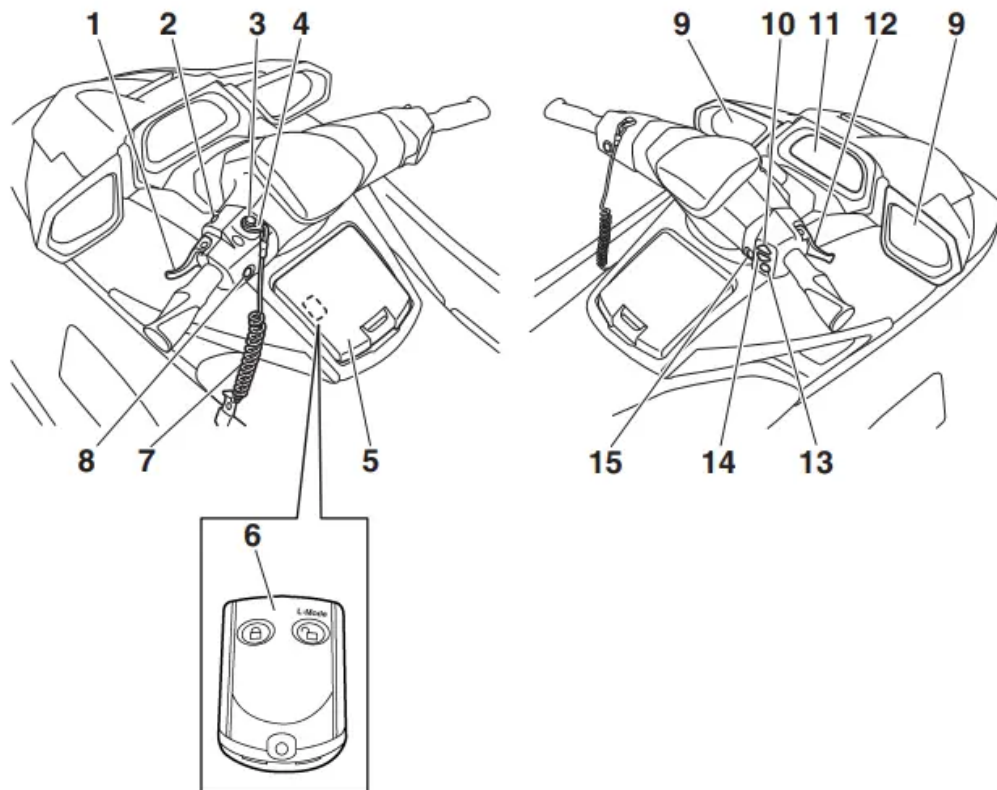

1. RiDE lever (VX / VX Deluxe / VX Cruiser / VX Limited) (page 37)
2. Start switch (page 33)
3. Engine shut-off switch (page 33)
4. Clip (page 33)
5. Glove compartment (page 53)
6. Remote control transmitter (VX Deluxe / VX Cruiser / VX Limited) (page 31)
7. Engine shut-off cord (lanyard) (page 33)
8. Engine stop switch (page 33)
9. Rearview mirror (VX / VX Deluxe / VX Cruiser / VX Limited)
10. Cruise assist up switch (VX Deluxe / VX Cruiser / VX Limited) (page 42)
11. Multifunction information center (page 44)
12. Throttle lever (page 34)
13. "SET" switch (VX Deluxe / VX Cruiser / VX Limited) (page 42)
14. Cruise assist down switch (VX Deluxe / VX Cruiser / VX Limited) (page 42)
15. "NO-WAKE MODE" switch (VX Deluxe / VX Cruiser / VX Limited) (page 40)

Engine compartment

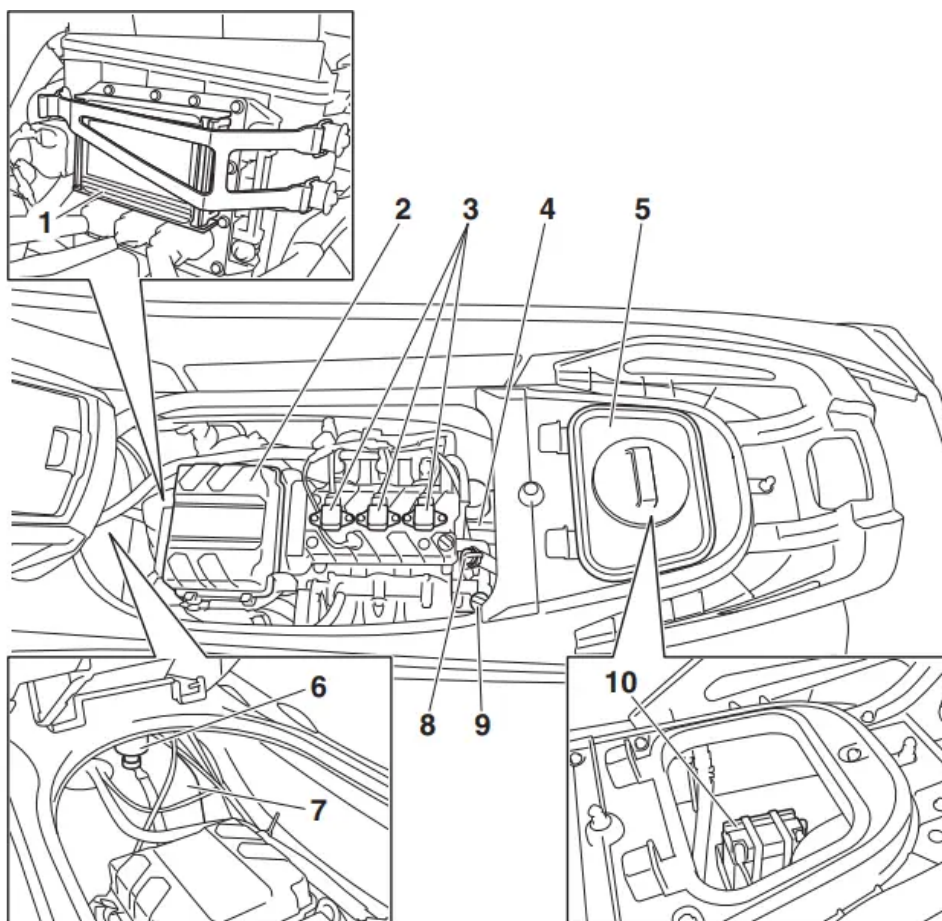

1. Fuse box
2. Air filter case
3. Spark plug/Ignition coil
4. Oil tank
5. Removable watertight storage compartment (page 54)
6. Water separator (page 35)
7. Fuel tank
8. Flushing hose connector (page 86)
9. Oil tank filler cap/Dipstick 10 Battery (page 66)

Control function operation

EJU31026 Watercraft control functions

EJU43910 Remote control transmitter (VX Deluxe / VX Cruiser / VX Limited)

- The Yamaha Security System and Low RPM Mode settings can be selected by operating the remote control transmitter. (See page 32 for Yamaha Security System setting procedures and page 39 for Low RPM Mode activation procedures.)

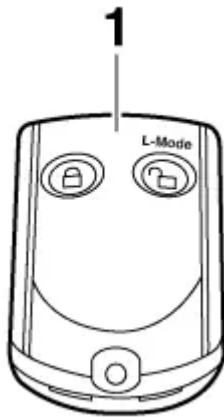

1. Remote control transmitter

- Since the watercraft is programmed to recognize the internal code from this transmitter only, the settings can only be selected with this transmitter.
- If you accidentally lose your remote control transmitter or if it is not operating properly, contact a Yamaha dealer.
- When operating the watercraft, always keep the transmitter with you, such as by storing it in the transmitter holder in the glove compartment, so that it is not lost.

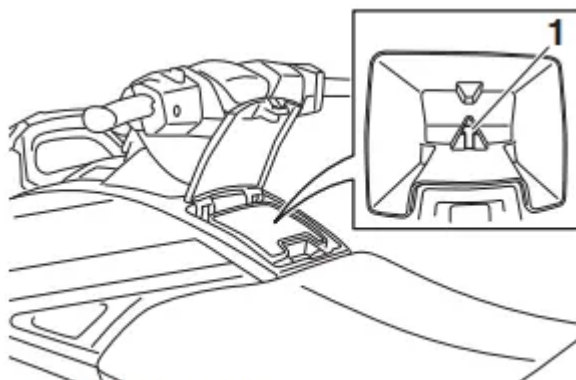

1 Transmitter holder

- This device complies with Part 15 of the FCC Rules. Operation is subject to the following two conditions: (1) this device may not cause harmful interference, and (2) this device must accept any interference received, including interference that may cause undesired operation.

EJU31385 Yamaha Security System (VX Deluxe / VX Cruiser / VX Limited)



- The Yamaha Security System functions to help prevent unauthorized use or theft of the watercraft. The lock and unlock modes of the security system can be selected by operating the remote control transmitter that is included with this watercraft. The engine cannot be started if the lock mode of the security system is selected. The engine can

only be started if the unlock mode is selected. (See page 31 for information on the remote control transmitter.)

TIP: The Yamaha Security System settings can only be selected while the engine is stopped.

EJU36776 Yamaha Security System settings

- The Yamaha Security System settings will be confirmed by the number of beeps when the remote control transmitter is operated, and by the “UNLOCK” indicator light of the multifunction information center. (See page 44 for information on the multifunction information center.)

Number of beeps	Yamaha Security System mode	“UN-LOCK” indicator light
	Lock	Goes off
	Unlock (normal operation mode)	Comes on
	Unlock (Low RPM Mode)	Comes on

TIP:

- The beeper sounds two times for the normal operation mode or three times for the Low RPM Mode. (See page 39 for Low RPM Mode activation procedures.)
- If the remote control transmitter is operated while the multifunction information center is in the standby state, the center will perform the initial operation, and then the setting is selected.

To select the lock mode:

- Push the lock button on the remote control transmitter briefly. The beeper sounds once and the “UNLOCK” indicator light blinks once, then goes off. This indicates the lock mode is selected.

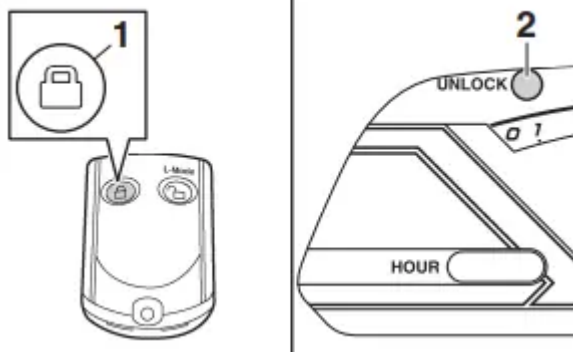

1. Lock button

2. "UNLOCK" indicator light

To select the unlock mode: Push the "L-Mode" (unlock) button on the remote control transmitter briefly. The beeper sounds two or three times and the "UNLOCK" indicator light blinks two or three times, then comes on. This indicates the unlock mode is selected

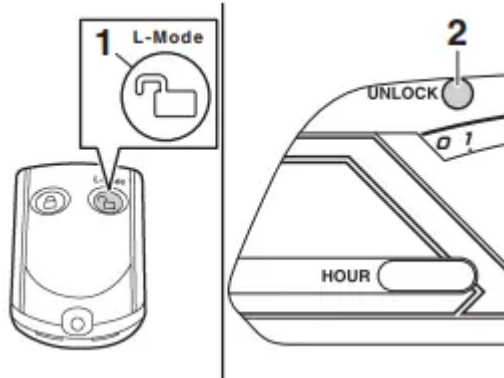

1. "L-Mode" (unlock) button
2. "UNLOCK" indicator light

EJU31153 Engine stop switch “”

- The engine stop switch (red button) stops the engine when the switch is pushed.

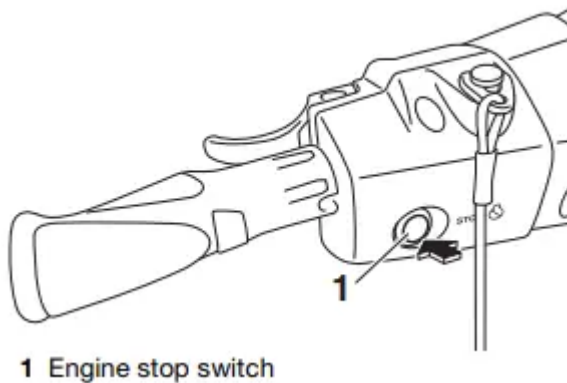

EJU31164 Engine shut-off switch “”

- The engine shut-off switch automatically stops the engine when the clip, on the end of the engine shut-off cord (lanyard), is removed from the switch, such as if the operator falls off the watercraft.

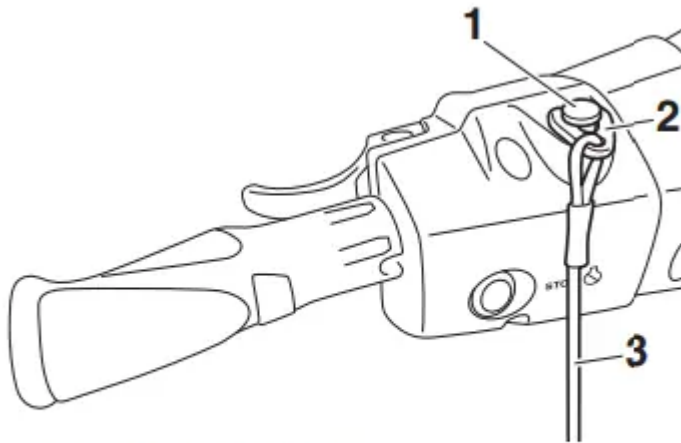

- 1** Engine shut-off switch
- 2** Clip
- 3** Engine shut-off cord (lanyard)

- When the engine is not running, remove the clip from the engine shut-off switch to prevent accidental starting or unauthorized operation by children or others.

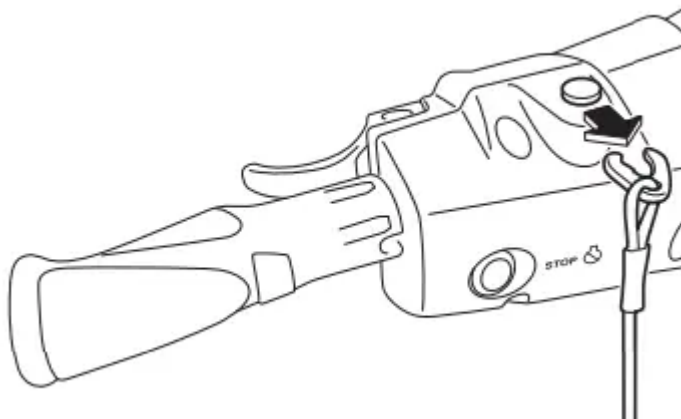

EJU43631 Start switch “”

- The start switch (green button) starts the engine when the switch is pushed.
- Release the start switch as soon as the engine starts to run. If the engine does not start in 5 seconds, release the start switch, wait 15 seconds, and then try again. **NOTICE:** Never push the start switch while the engine is running. Do not operate the start switch for more than 5 seconds, otherwise the battery will be discharged and the engine will not start. Also, the starter motor could be damaged. [ECJ01041]

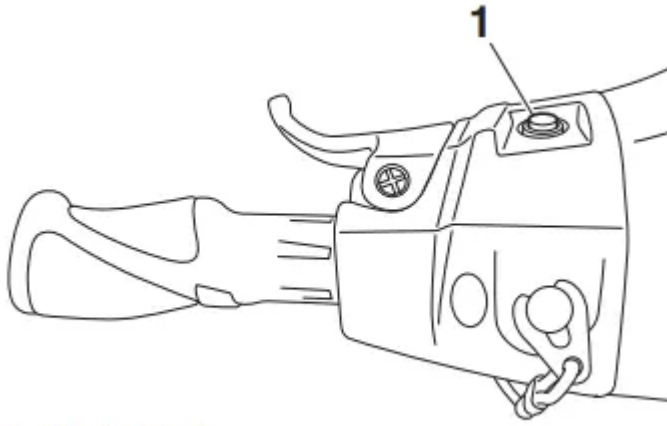

1 Start switch

The engine will not start under any of the following conditions:

- Clip is removed from the engine shut-off switch.
- Throttle lever is squeezed.
- Throttle lever is malfunctioning.
- VX / VX Deluxe / VX Cruiser / VX Limited: RiDE lever is squeezed.
- VX / VX Deluxe / VX Cruiser / VX Limited: RiDE lever is malfunctioning.
- VX Deluxe / VX Cruiser / VX Limited: Lock mode of the Yamaha Security System has been selected. (See page 32 for Yamaha Security System setting procedures.)

EJU31212 Throttle lever

- The throttle lever increases the engine speed when the lever is squeezed.

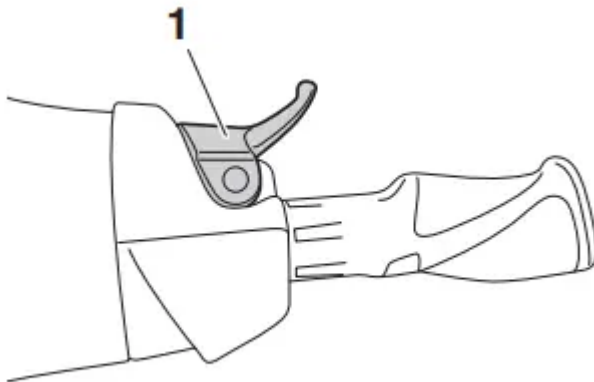

1 Throttle lever

- The throttle lever returns automatically to its fully closed (idle) position when released.

EJU43342 RiDE lever (VX / VX Deluxe / VX Cruiser / VX Limited)

- When the RiDE lever is squeezed, the reverse gate lowers and the watercraft starts moving in reverse. If the watercraft is moving forward, the watercraft gradually slows down until it stops, and then the watercraft starts moving in reverse.

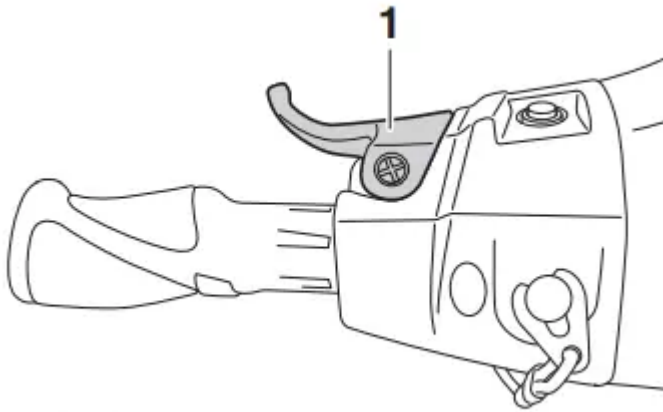

1 RiDE lever

- When the RiDE lever is released, it automatically returns to its fully closed (idle) position and the reverse gate moves to the neutral position.

EJU31262 Steering system

- By turning the handlebars in the direction you wish to travel, the angle of the jet thrust nozzle is changed, and the direction of the watercraft is changed accordingly.

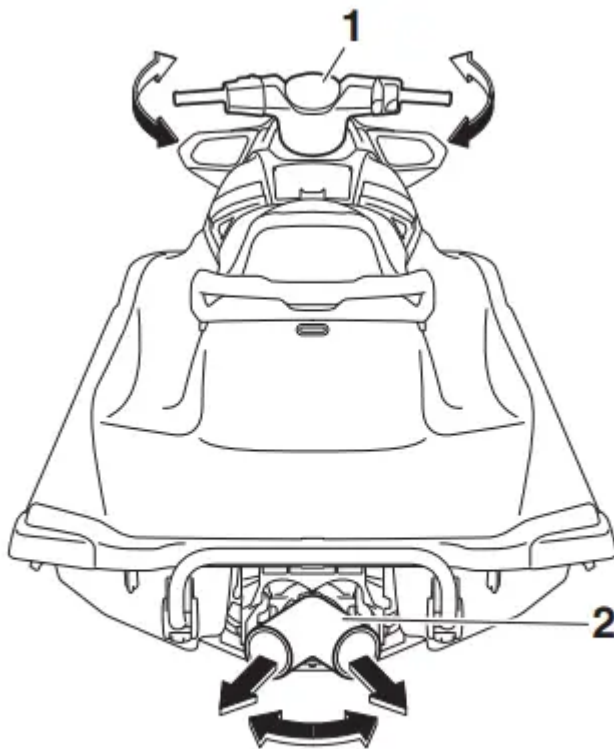

1 Handlebar

2 Jet thrust nozzle

- Since the strength of the jet thrust determines the speed and degree of a turn, throttle must always be applied when attempting a turn, except at trolling speed.
- This model is equipped with the Yamaha Engine Management System (YEMS) that includes an off-throttle steering (OTS) system. It will activate at planing speeds should you attempt to steer the watercraft after releasing the throttle lever. The OTS system assists in turning by continuing to supply some thrust while the watercraft is decelerating, but you can turn more sharply if you apply throttle while turning the handlebars. The OTS system does not function below planing speeds or when the engine is off. Once the engine slows down, the watercraft will no longer turn in response to handlebar input until you apply throttle again or you reach trolling speed.

EJU35975 Cooling water pilot outlet

- When the engine is running, some of the cooling water that is circulated in the engine is discharged from the cooling water pilot outlet.

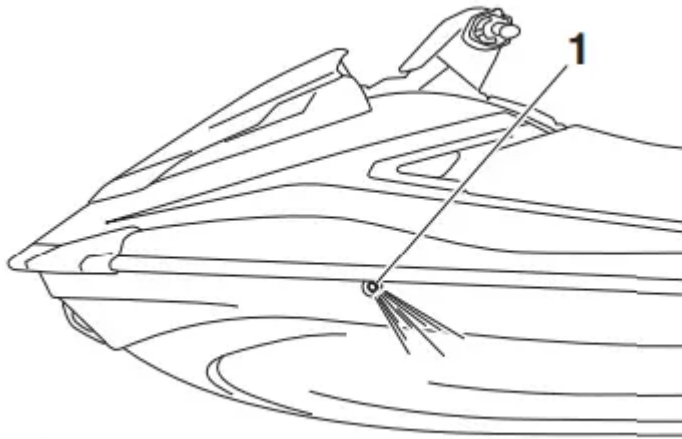

1 Cooling water pilot outlet

- There is a cooling water pilot outlet on the port (left) side of the watercraft. To check for proper operation of the cooling system, make sure that water is being discharged from the cooling water pilot outlet. If water is not being discharged from the outlet, stop the engine and check the jet intake for clogging. (See page 100 for information on the jet intake.)

TIP:

- It will take about 60 seconds for the water to reach the outlet after the engine is started.
- Water discharge may not be constant when the engine is running at idling speed. If this occurs, apply a little throttle to make sure that water discharges properly.

EJU40323 Water separator

- The water separator prevents water from entering the fuel tank by collecting any water that has entered the fuel tank breather hose if the watercraft was capsized.
- If water has collected in the water separator, drain it by loosening the drain screw.

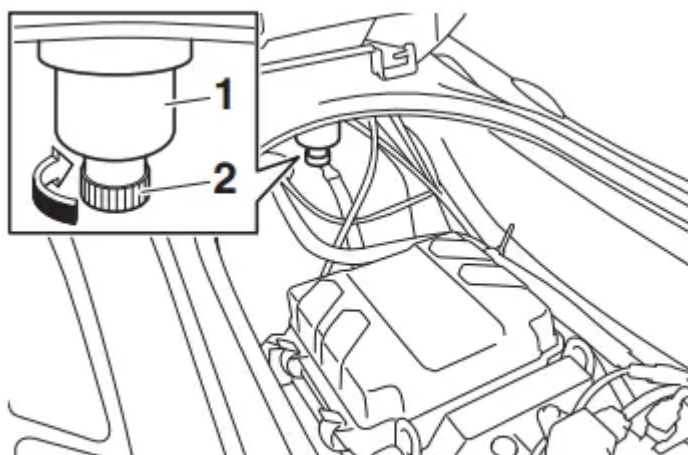

1 Water separator

2 Drain screw

To drain water from the water separator:

1. Place a drain pan or dry cloth under the water separator.
2. Gradually loosen the drain screw to drain the water. Catch the draining water in the drain pan or soak it up with the dry cloth so that it does not spill into the engine compartment. If any water spills into the watercraft, be sure to wipe it up with a dry cloth.
3. Securely tighten the drain screw until it stops.

Equipment operation

Equipment

Seats

The front and rear seats are removable. Remove the seats to access the engine compartment and removable watertight storage compartment.

To remove the rear seat:

- (1) Pull the rear seat latch up, and then lift up the rear of the seat.

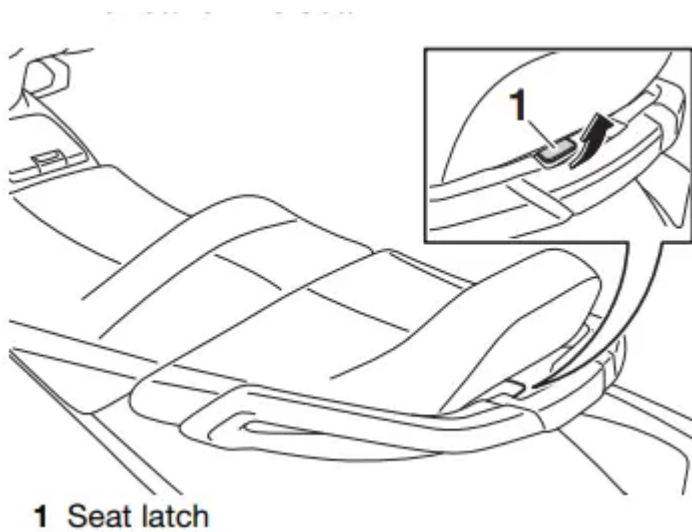

- (2) Pull the seat rearward and remove it.

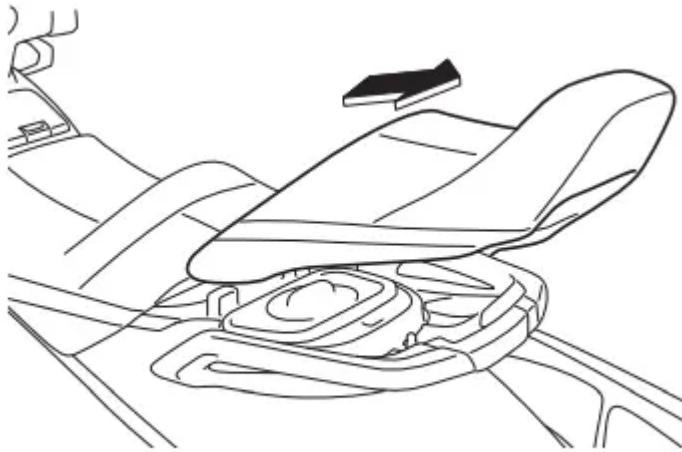

To install the rear seat:

- (1) Insert the projections on the front of the seat into the stays on the deck.

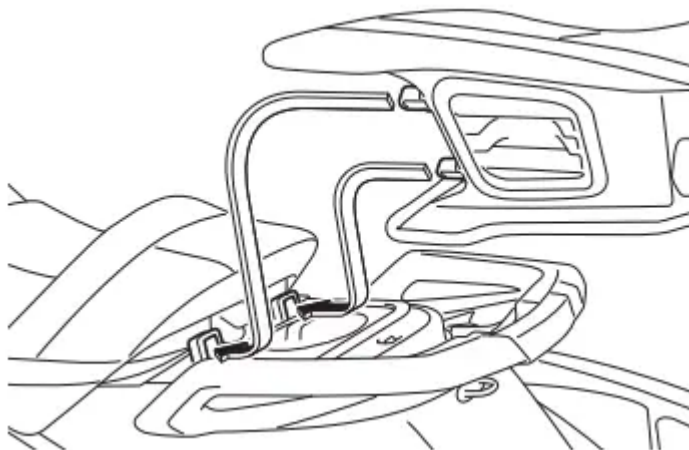

- (2) Push the rear of the seat down to securely lock it in place.

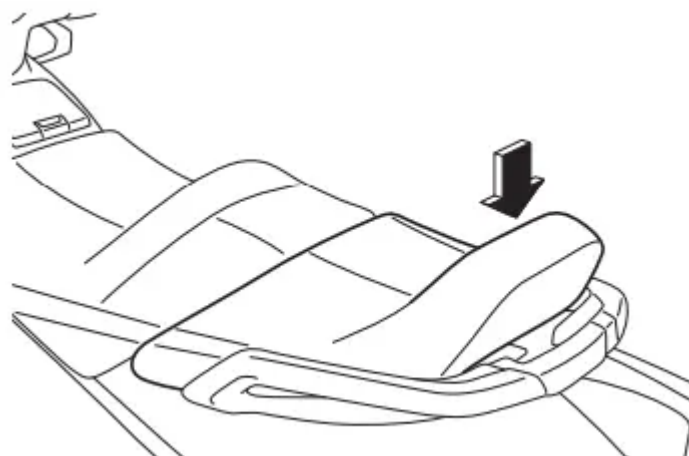

To remove the front seat:

- (1) Remove the rear seat.
- (2) Pull the front seat latch up, and then lift up the rear of the seat.

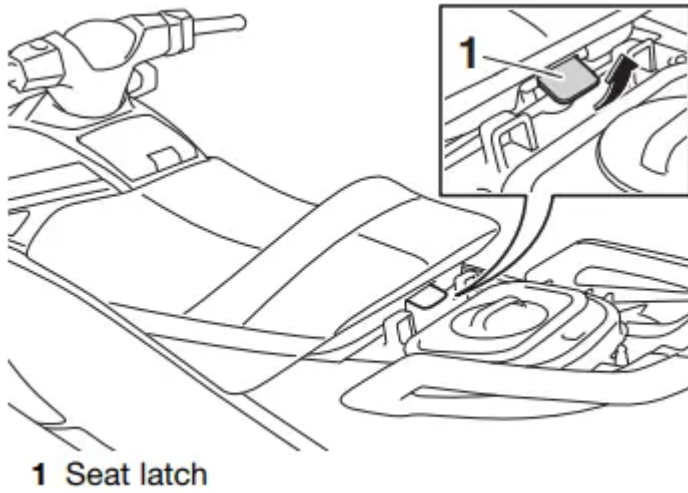

- (3) Pull the seat rearward and remove it

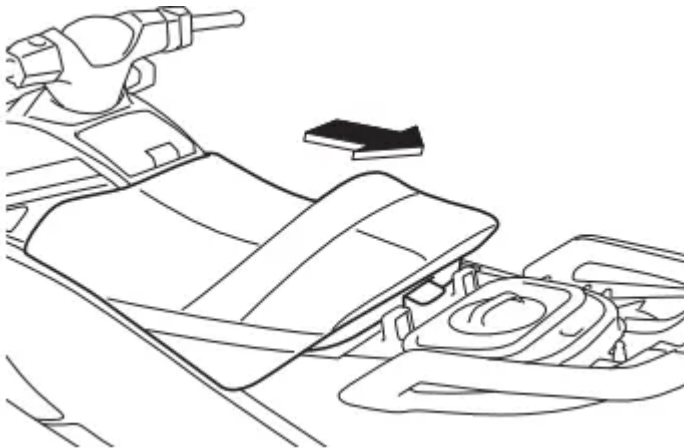

To install the front seat:

- (1) Insert the projection on the front of the seat into the stay on the deck.

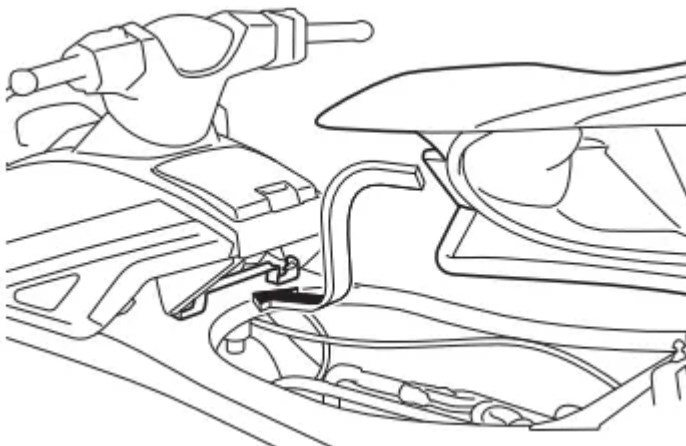

(2) Push the rear of the seat down to securely lock it in place.

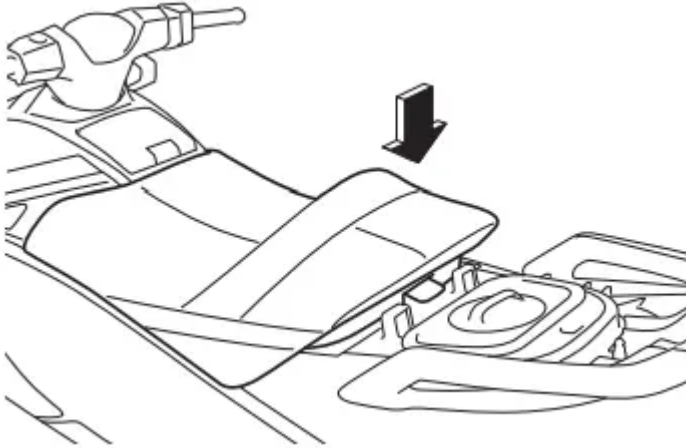

(3) Securely install the rear seat in its original position.

Handgrip

- The handgrip is used when boarding the watercraft from the water and when the spotter is facing rearward. **WARNING!** Do not use the handgrip to lift the watercraft. The handgrip is not designed to support the watercraft's weight. If the handgrip breaks, the watercraft could fall, which could result in severe injury. [EWJ00022]

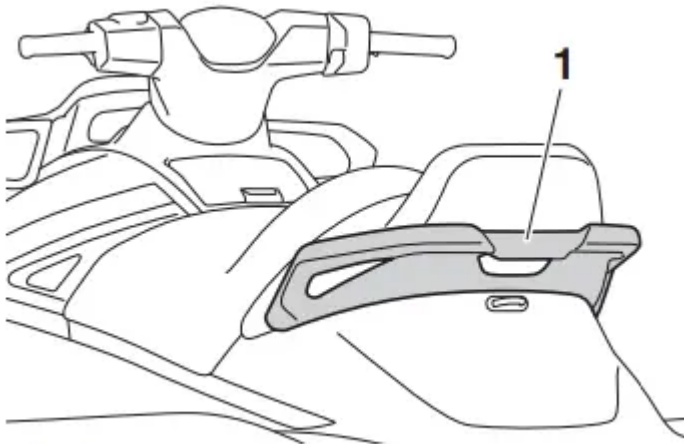

1 Handgrip

Reboarding step (VX / VX Deluxe / VX Cruiser / VX Limited)

- The reboarding step is used to assist in reboarding the watercraft from the water. When boarding the watercraft, push the reboarding step down until it stops. The step returns automatically to its original position when released. **WARNING!** Do not use the reboarding step to lift the watercraft. The reboarding step is not designed to support the watercraft's weight. If the reboarding step breaks, the watercraft could fall, which could result in severe injury. [EWJ01212]

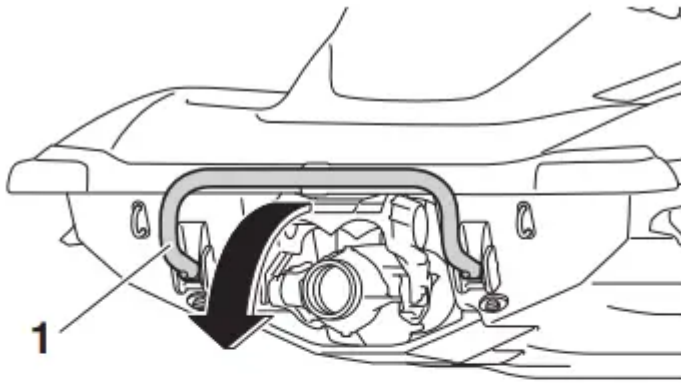

1 Reboarding step

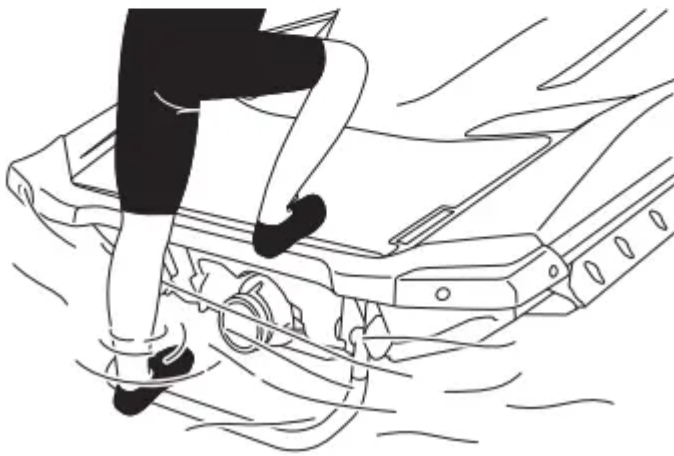

Bow eye

- The bow eye is used to attach a rope to the watercraft when transporting, mooring, or towing it in an emergency. (See page 102 for information on towing the watercraft.)

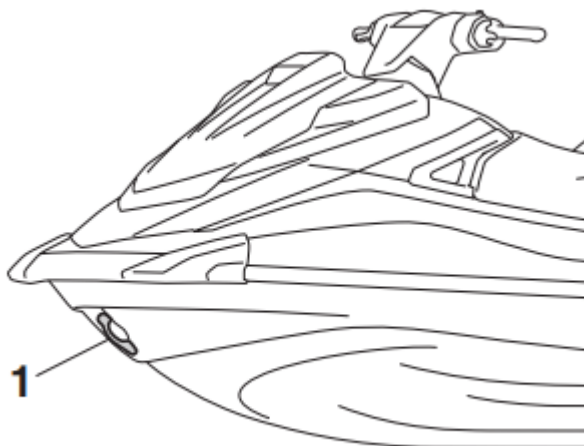

1 Bow eye

Stern eyes

- The stern eyes are used to attach a rope to the watercraft when transporting or mooring it.

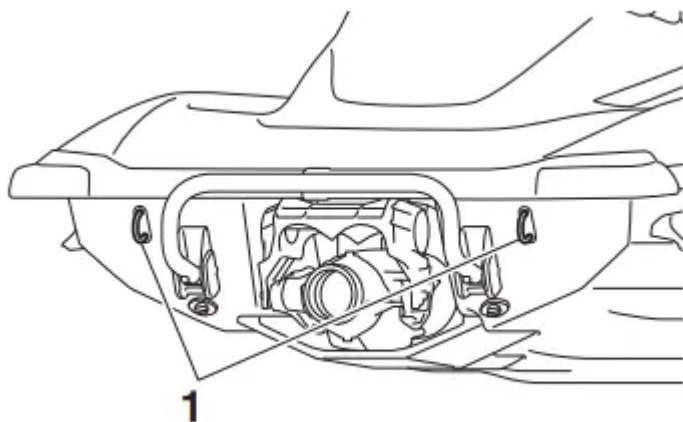

1 Stern eye

Cleat

- The cleat is used to attach a ski rope to the watercraft when pulling a wakeboarder or water-skier. **WARNING!** Do not use the cleat to lift the watercraft. The cleat is not designed to support the watercraft's weight. If the cleat breaks, the watercraft could fall, which could result in severe injury. [EWJ01511]

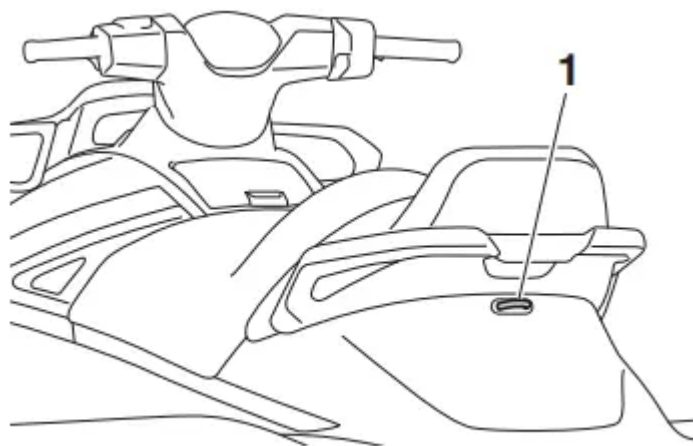

1 Cleat

Pull-up cleats (VX Limited)

- The pull-up cleats are used to attach a rope to the watercraft when mooring it. To use a pull-up cleat, pull it up. The pull-up cleat returns automatically to its original position when released. **WARNING!** Do not use the pull-up cleats to lift the watercraft. The pull-up cleats are not designed to support the watercraft's weight. If the pull-up cleats break, the watercraft could fall, which could result in severe injury. [EWJ00822]

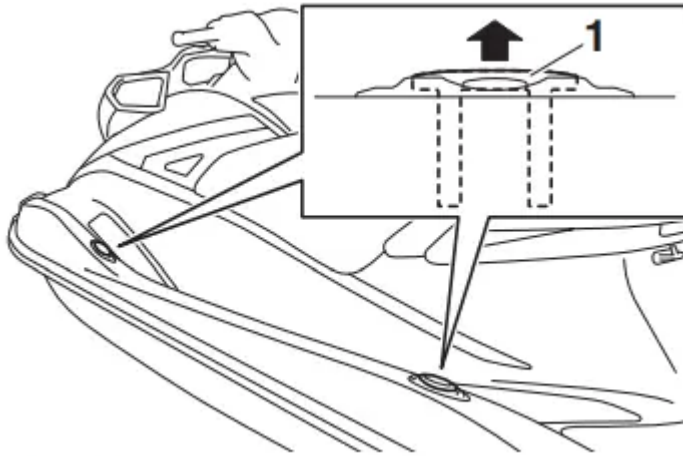

1 Pull-up cleat

Storage compartments

- This watercraft is equipped with the following storage compartments.
- Only the securely closed watertight storage compartment is waterproof. If you carry objects that must be kept dry, put them in a waterproof bag.
- Make sure that the storage compartments are closed securely before operating the watercraft.

Bow storage compartment

The bow storage compartment is located under the hood.

To open the bow storage compartment:

- Pull the hood latch up, and then lift up the rear of the hood.

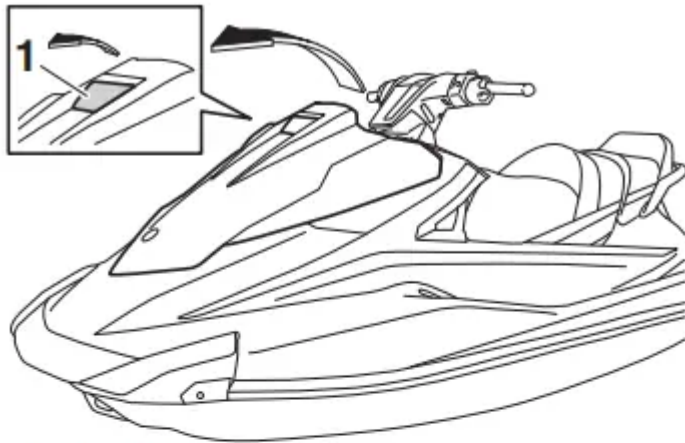

1 Hood latch



1 Bow storage compartment

To close the bow storage compartment:

- Return the hood to its original position, and then push the hood latch down to securely lock it in place.

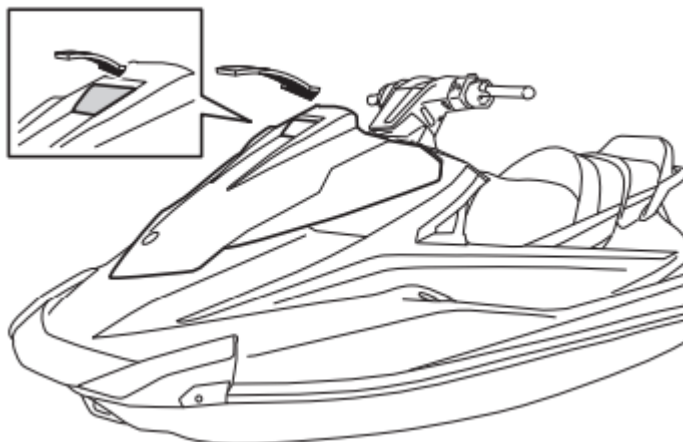

To drain water from the bow storage compartment:

(1) Remove the drain plug on the bottom of the storage compartment to drain the water into the engine compartment.

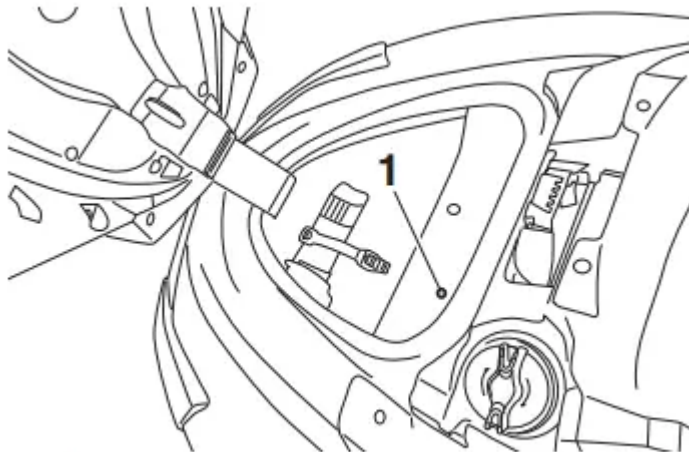

1 Drain plug

(2) Securely install the drain plug in its original position.

Glove compartment

- The glove compartment is located in front of the seat.

To open the glove compartment:

Pull the glove compartment latch up, and then lift up the lid.

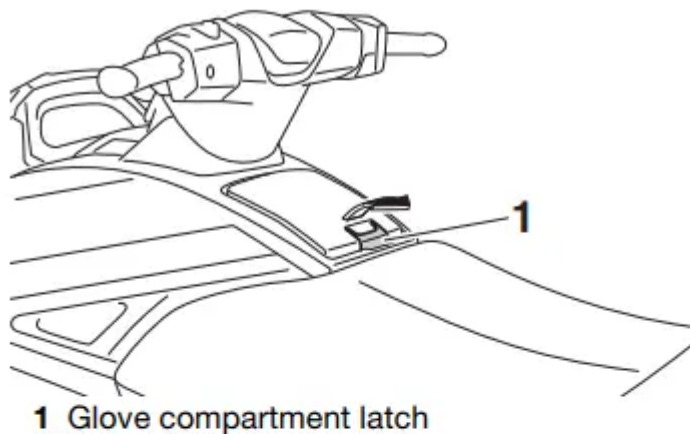

1 Glove compartment latch

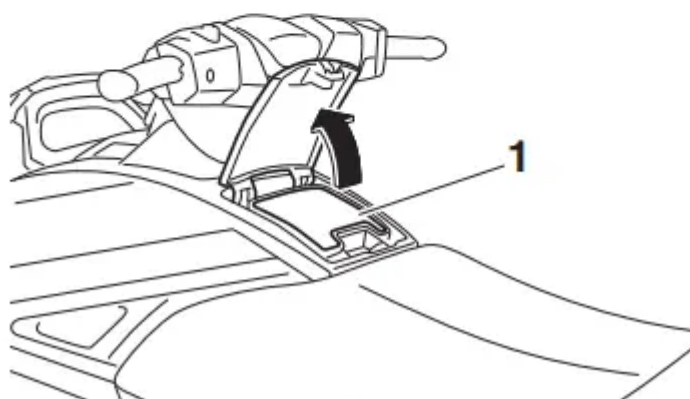

1 Glove compartment

To close the glove compartment:

Push the lid down to securely lock it in place

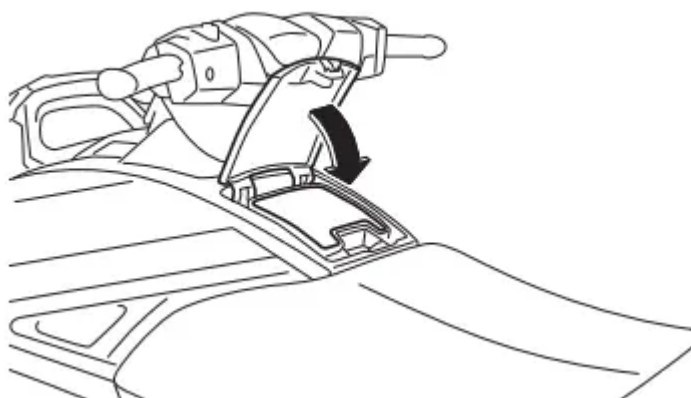

Removable watertight storage compartment

The removable watertight storage compartment is located under the rear seat. The compartment is watertight when the cap is closed securely.

To open the removable watertight storage compartment:

- (1) Remove the rear seat. (See page 49 for seat removal and installation procedures.)
- (2) Loosen the cap and remove it.

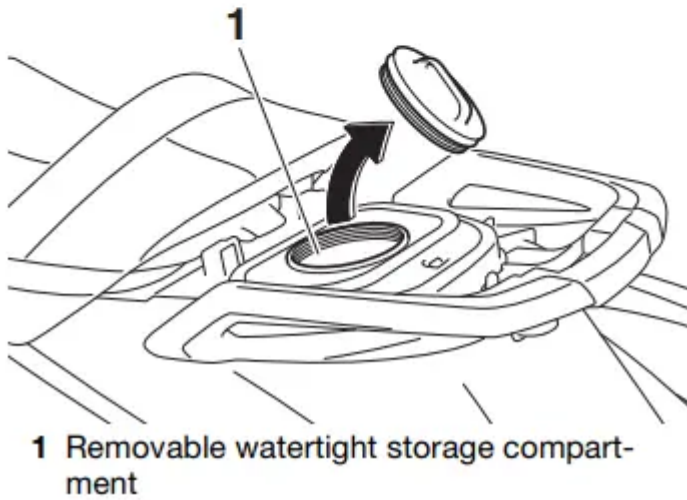
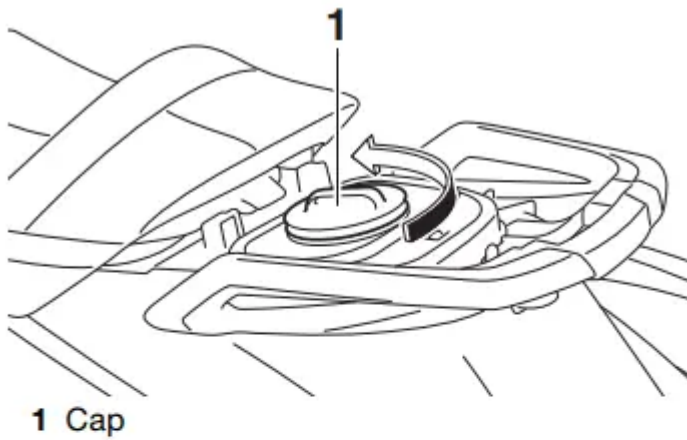

To close the removable watertight storage compartment:

- (1) Securely install the cap by tightening it until it stops.
- (2) Securely install the rear seat in its original position.

Fire extinguisher holder and cover

The fire extinguisher holder and cover are located in the bow storage compartment.

To use the fire extinguisher holder and cover:

- (1) Pull the hood latch up, and then lift up the rear of the hood.

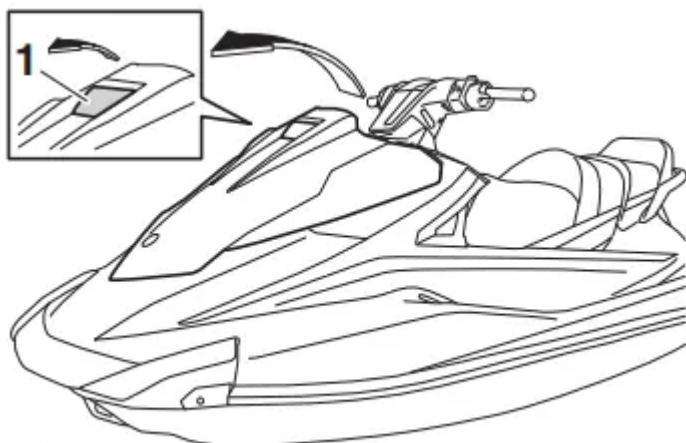

1 Hood latch

(2) Unhook the band and remove the fire extinguisher from the fire extinguisher cover

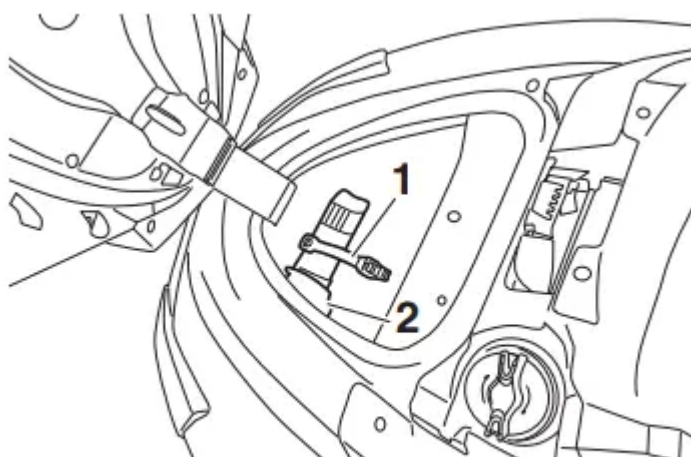

1 Band

2 Fire extinguisher holder and cover

(3) Place the fire extinguisher in the fire extinguisher cover, and then securely fasten the fire extinguisher with the band.

(4) Return the hood to its original position, and then push the hood latch down to securely lock it in place. Make sure that the hood is securely closed before using the watercraft.

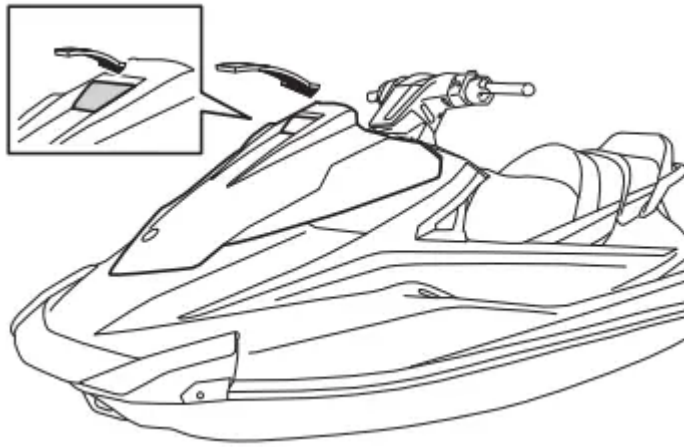

First-time operation

Engine break-in

NOTICE: Failure to perform the engine break-in could result in reduced engine life or even severe engine damage.

The engine break-in is essential to allow the various components of the engine to wear and polish themselves to the correct operating clearances. This ensures proper performance and promotes longer component life.

To perform the engine break-in:

1. Check the engine oil level. (See page 58 for information on checking the engine oil level.)
2. Launch the watercraft and start the engine. (See page 74 for information on starting the engine.)
3. For the first 5 minutes, operate with the engine at idling speed.
4. For the next 30 minutes, operate with the engine speed below 5000 r/min.
5. For the next 1 hour, operate with the engine speed below 6500 r/min.

After the engine break-in is complete, the watercraft can be operated normally.

Operation

Operating your watercraft

WARNING: Before operating your watercraft, become familiar with all of the controls. Consult a Yamaha dealer about any control or function that you do not fully understand. Failure to understand how the controls work could cause an accident or prevent you from avoiding an accident.

Getting to know your watercraft

- Operating your watercraft requires skills acquired through practice over a period of time. Take the time to learn the basic techniques well before attempting more difficult maneuvers.
- Operating your new watercraft can be a very enjoyable activity, providing you with hours of pleasure. However, it is essential to familiarize yourself with the operation of the watercraft to achieve the skill level necessary to enjoy riding safely.
- Before operating this watercraft, read this owner's/operator's manual, the Riding Practice Guide, the Riding Instruction card, and all labels on the watercraft. Pay particular attention to the safety information beginning on page 10. Also, watch the WaveRunner Basic Orientation Video linked to the following QR code. yamahawaverunners.com/orientation A DVD is also available your nearest dealer for your convenience.
- These materials should give you an understanding of the watercraft and its operation. Remember: This watercraft is designed to carry the operator and up to 2 passengers. Never exceed the maximum load limit or allow more than 3 persons (or 2 persons if a wakeboarder or water-skier is being pulled) to ride the watercraft at any time.

<p>Maximum load: 240 kg (530 lb) Load is the total weight of cargo, operator, and passengers.</p>
--

Learning to operate your watercraft

- Before operating the watercraft, always perform the pre-operation checks listed on page 63. The short time spent checking the watercraft will reward you with added safety and reliability.
- Check state and local laws before operating your watercraft.
- Operate defensively at safe speeds and keep a safe distance away from people, objects, and other watercraft. Select a wide area to learn in, where there is good visibility and light boat traffic.

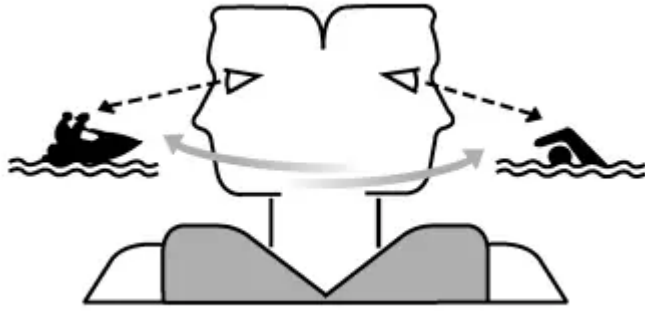

- Use the buddy system—operate with someone nearby. Scan constantly for people, objects, and other watercraft. Be alert for conditions that limit your visibility or block your vision of others.
- You should grip the handlebars firmly and keep both feet on the floor of the footwell. Do not attempt to ride with passengers until your operating skills are fully developed.

Riding position

- Operator riding position: The operator should grip the handlebars firmly with both hands and sit astride the seat with both feet on the floor of the footwell.



- Passenger riding position: The passenger(s) should hold on firmly, either to the person in front of them or to the handgrip provided, and sit astride the seat with their feet on the floor of the footwell. Never allow a passenger to ride in front of the operator. (See page 18 for information on the riding position when pulling a wakeboarder or water-skier.)



Launching the watercraft

- When launching the watercraft, make sure that there are no obstacles around you. If the watercraft is launched from a trailer, someone should make sure that waves do not push the watercraft into the trailer.

Starting the engine on water

WARNING: Do not apply throttle when anyone is at the rear of the watercraft. Turn the engine off or keep it at idle. Water and debris exiting the jet thrust nozzle can cause severe injury.

To start the engine:

- (1) VX Deluxe / VX Cruiser / VX Limited: If the lock mode is selected for the Yamaha Security System setting, select the unlock mode. (See page 32 for Yamaha Security System setting procedures.)
- (2) Move the watercraft to an area that is free from weeds and debris, and has a water depth of at least 60 cm (2 ft) from the bottom of the watercraft. **NOTICE:** Never run the engine in water that is less than 60 cm (2 ft) deep from the bottom of the watercraft, otherwise pebbles or sand could be sucked into the jet intake, causing impeller damage and engine overheating. [ECJ00473]

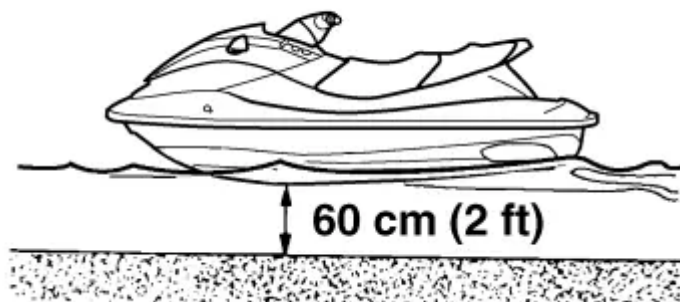

- (3) Attach the engine shut-off cord (lanyard) to your left wrist, and then attach the clip to the engine shut-off switch. (See page 33 for information on operating the engine shut-off switch.) **WARNING!** Check that the engine shut-off cord (lanyard) is attached correctly. If the engine shut-off cord (lanyard) is not attached correctly, it may not pull free when the operator falls off, allowing the watercraft to continue to run and cause an accident. [EWJ00582]

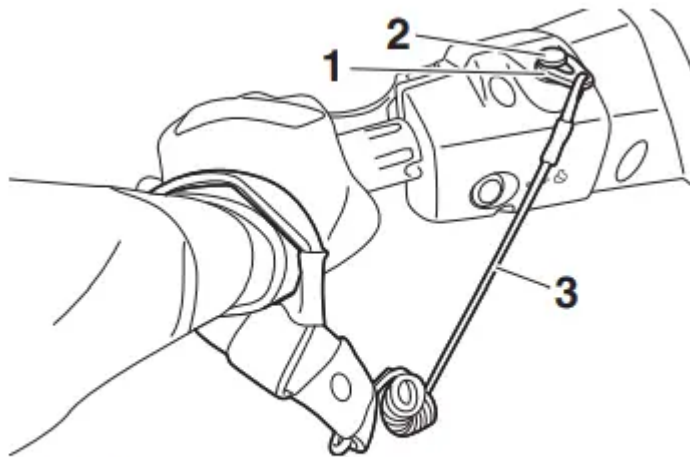

- 1 Clip
- 2 Engine shut-off switch
- 3 Engine shut-off cord (lanyard)

(4) With the throttle lever released, push the start switch (green button) to start the engine.
(See page 33 for information on operating the start switch.)

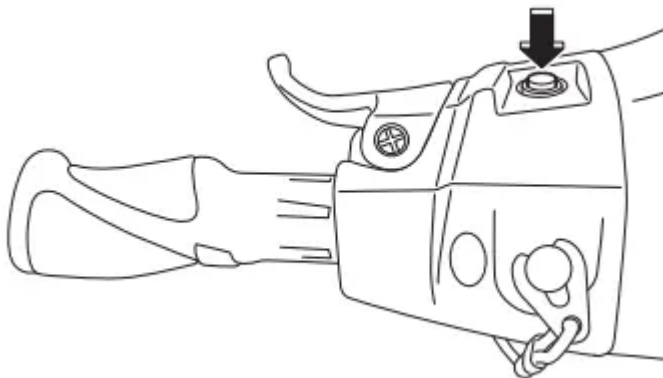

Stopping the engine

- Release the throttle lever, and then push the engine stop switch (red button) to stop the engine. **WARNING!** You need throttle to steer. Shutting the engine off can cause you to hit an obstacle you are attempting to avoid. A collision could result in severe injury or death. [EWJ00602]

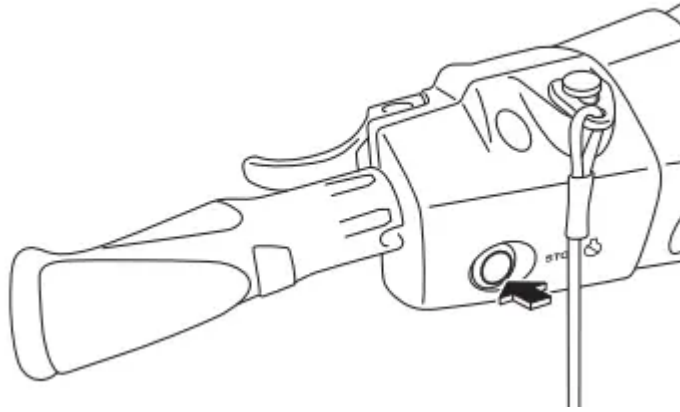

Leaving the watercraft

- If leaving the watercraft, remove the clip from the engine shut-off switch to prevent accidental starting or unauthorized operation by children or others.

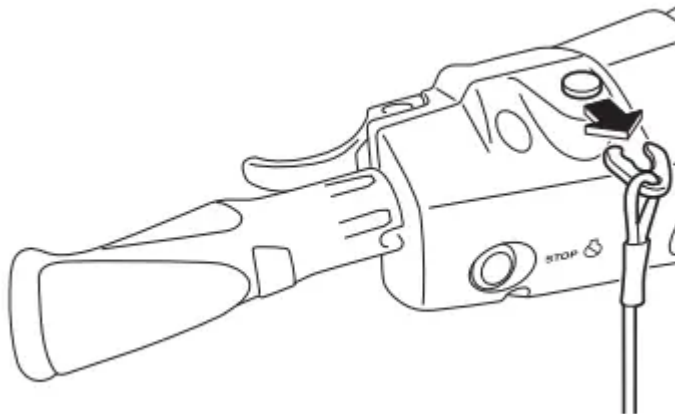

Operating the watercraft VX-C:

When the engine is running, the watercraft will move forward at trolling speed even if the throttle lever is in the fully closed (idle) position.



VX / VX Deluxe / VX Cruiser / VX Limited: When the throttle lever is squeezed, the “F” (forward) shift indicator will be displayed and the watercraft will move forward. While the “F” (forward) shift

indicator is displayed, the watercraft will move forward at trolling speed even if the throttle lever is in the fully closed (idle) position. (See page 37 for shift system operation procedures.)

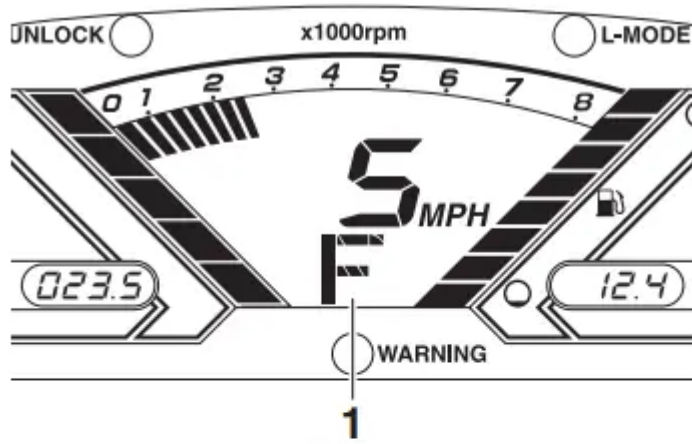

1 "F" (Forward position)



Turning the watercraft

Steering control depends on the combination of handlebar position and the amount of throttle.

Water sucked in through the intake grate is pressurized by the impeller in the jet pump. As the pressurized water is expelled from the pump through the jet thrust nozzle, it creates thrust to move and steer the watercraft. The higher the engine speed, the more thrust produced.

The amount of jet thrust, in addition to the position of the handlebars, determines how sharply you turn.

- A. More throttle produces higher thrust, so the watercraft will turn more sharply.



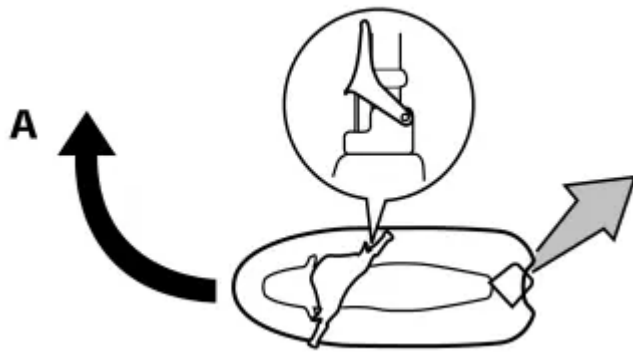

B. Less throttle produces lower thrust, so the watercraft will turn more gradually

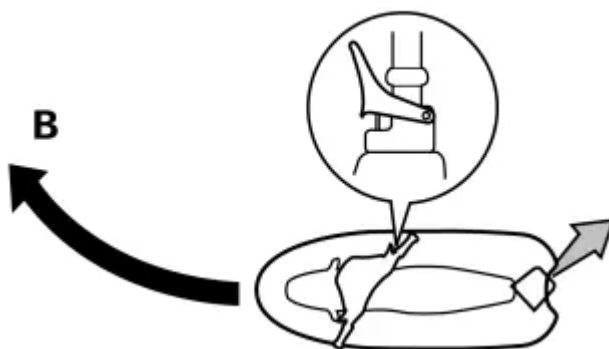

C. Releasing the throttle lever completely produces only minimum thrust. If you are traveling at speeds above trolling, you will have rapidly decreasing ability to steer without throttle. You may still have some turning ability immediately after releasing the throttle lever, but once the engine slows down, the watercraft will no longer respond to handlebar input until you apply throttle again or you reach trolling speed.

At trolling speed, the watercraft can be turned gradually by handlebar position alone using just the amount of thrust available at idle

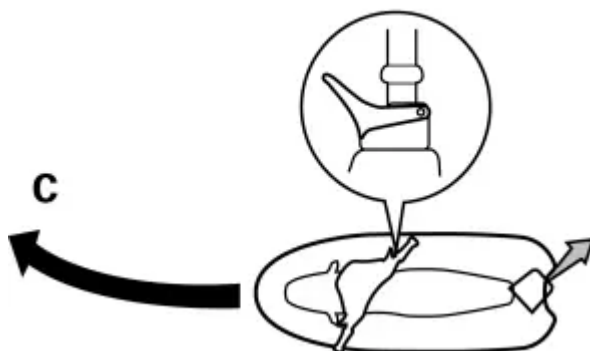

D. If the engine is stopped while riding, there is no thrust. The watercraft will go straight even though the handlebars are turned.

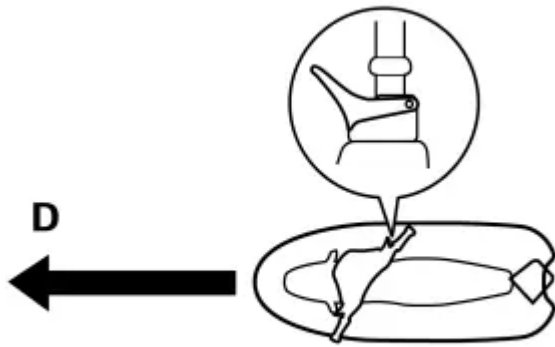

You need throttle to steer.

E. VX / VX Deluxe / VX Cruiser / VX Limited: If the RiDE lever is squeezed and the handlebars are turned when the watercraft is cruising at planing speed, the watercraft will turn gradually while slowing down.

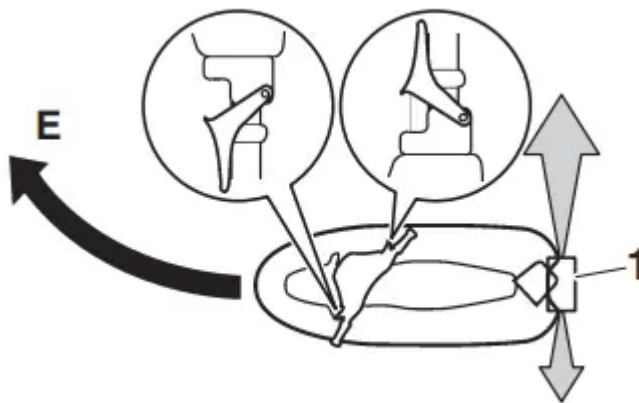

1 Reverse gate

This model is equipped with the Yamaha Engine Management System (YEMS) that includes an off-throttle steering (OTS) system. It will activate at planing speeds should you attempt to steer the watercraft after releasing the throttle lever (see condition C above). The OTS system assists in turning by continuing to supply some thrust while the watercraft is decelerating, but you can turn more sharply if you apply throttle while turning the handlebars. The OTS system does not function below planing speeds or when the engine is off. Once the engine slows down, the watercraft will no longer turn in response to handlebar input until you apply throttle again or you reach trolling speed.

Care and storage

Post-operation care

- After using the watercraft, always take it out of the water, clean it, and store it. Leaving the watercraft in the water for extended periods will accelerate the rate of normal deterioration of the jet pump and hull. Marine organisms and corrosion are some of the conditions that can shorten the life of many watercraft components.

Flushing the cooling water passages

Flush the cooling water passages to prevent them from clogging with salt, sand, or dirt.

- (1) Place the watercraft in a horizontal position.
- (2) Remove the seats and removable watertight storage compartment. (See page 49 for seat removal and installation procedures and page 54 for information on the removable watertight storage compartment.)
- (3) Connect the garden hose adapter to a garden hose.

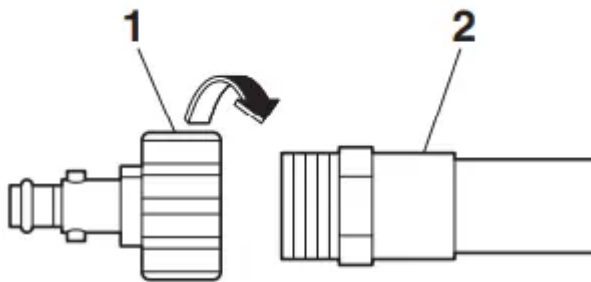

1 Garden hose adapter

2 Garden hose

- (4) Loosen the flushing hose connector cap and remove it. Insert the garden hose adapter into the flushing hose connector by pushing and twisting it until it is securely connected.

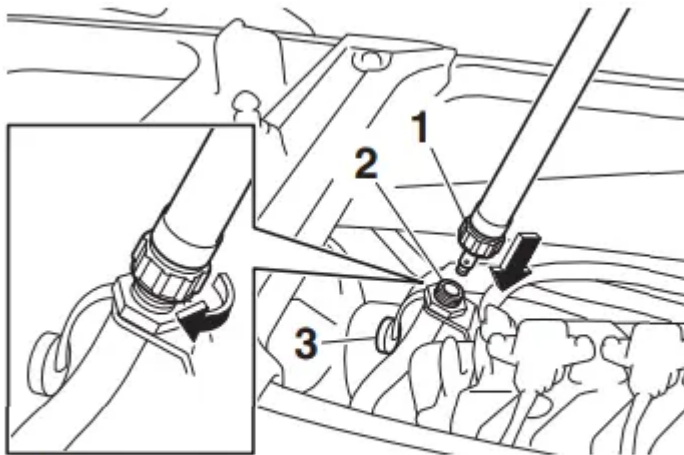

- 1** Garden hose adapter
- 2** Flushing hose connector
- 3** Flushing hose connector cap

(5) Connect the garden hose to a water tap.

(6) Make sure that the area around the watercraft is clear, and then start the engine. Immediately after the engine starts, fully turn the water supply on so that water flows out continually from the jet thrust nozzle.

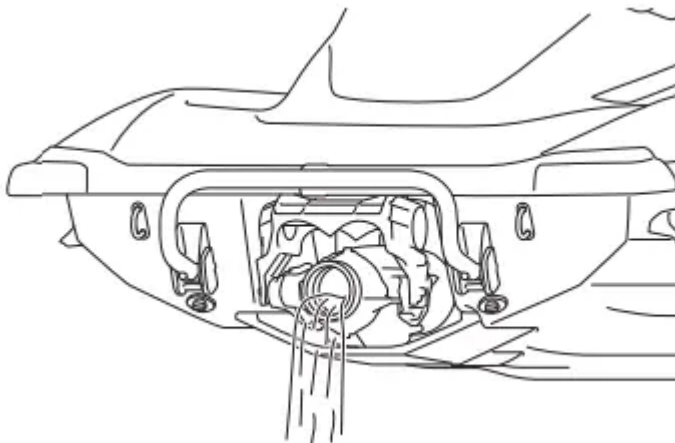

(7) Run the engine at idling speed for about 3 minutes watching the engine condition. If the engine stops while flushing, turn the water supply off immediately and perform the procedure again from step 6. **NOTICE:** Do not supply water to the cooling water passages when the engine is not running. The water could flow back through the muffler into the engine, causing severe engine damage. [ECJ00123]

(8) Turn the water supply off.

(9) Discharge the remaining water out of the cooling water passages by alternately squeezing and releasing the throttle lever quickly for 10 to 15 seconds.

(10) Stop the engine.

(11) Remove the garden hose adapter, and then securely install the flushing hose connector cap by tightening it until it stops.

(12) Securely install the removable watertight storage compartment and seats in their original positions

Cleaning the watercraft

(1) Remove the seats. (See page 49 for seat removal and installation procedures.)

(2) If the watercraft will be stored for a week or more, rustproof the internal engine components to help prevent corrosion. (See page 90 for information on rustproofing the internal engine components.)

(3) Rinse the engine and engine compartment with a small amount of water. NOTICE: Do not use high-pressure water when rinsing the engine or engine compartment as severe engine damage could result. [ECJ00572]

(4) Drain the water from the engine compartment. (See page 60 for information on draining the bilge water.)

(5) Wipe the engine and engine compartment with a dry cloth.

(6) Wash down the hull, deck, and jet pump with fresh water.

(7) Wipe the hull, deck, and jet pump with a dry cloth.

(8) Wipe all vinyl and rubber components, such as the seats and engine compartment seals, with a vinyl protectant such as Yamaclean Vinyl Dressing™.

(9) To minimize corrosion, spray metallic parts of the hull, deck, and engine with a rust inhibitor such as Yamalube Silicone Protectant & Lubricant.

(10) Allow the engine compartment to air dry completely before installing the seats.

(11) Securely install the seats in their original positions.

Battery care

- If the watercraft will not be used for more than a month, remove the battery from the watercraft, check it, and then store it in a cool, dry place.

To remove the battery:

1. Disconnect the negative (–) battery lead.
2. Disconnect the positive (+) battery lead.
3. Disconnect the breather hose.
4. Unhook the battery bands, and then remove the battery from the watercraft.

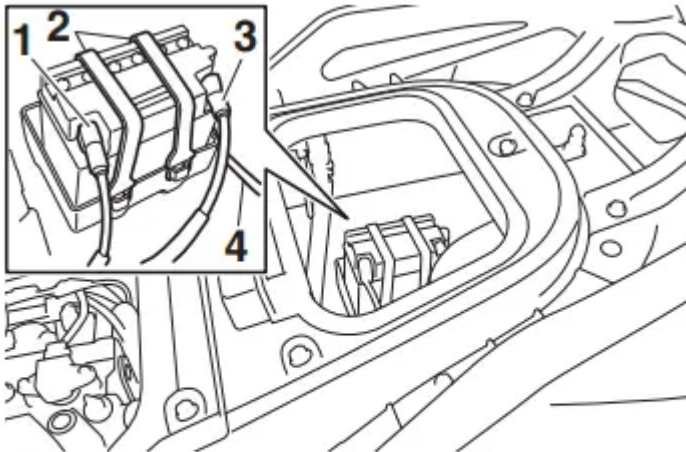

- 1 Negative (-) battery terminal: Black lead
- 2 Battery band
- 3 Positive (+) battery terminal: Red lead
- 4 Breather hose

Checking the battery

- Make sure that the battery case is not damaged.
- Make sure that the battery terminals are not corroded or damaged.
- Make sure that the breather hose is not clogged or damaged.

Checking the electrolyte level

- Make sure that the electrolyte level is between the maximum and minimum level marks.
- If the electrolyte level is low, add distilled water to raise it to the specified level. NOTICE: Use only distilled water for replenishing the battery, otherwise battery life could be shortened. [ECJ00242]

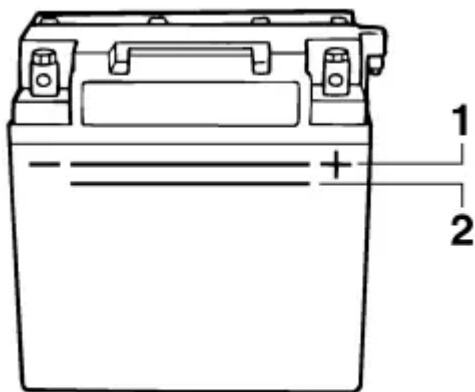

- 1 Maximum level mark
- 2 Minimum level mark

- If distilled water was added, check the battery voltage.

- It is recommended to have a Yamaha dealer check the battery voltage and charge the battery. If you charge the battery yourself, be sure to read and follow the instructions provided with the battery tester and charger you use. **NOTICE:** Do not attempt to charge a battery hastily. Battery life could be shortened. [ECJ00252]

Checking the battery bands

Make sure that the battery bands are not damaged.

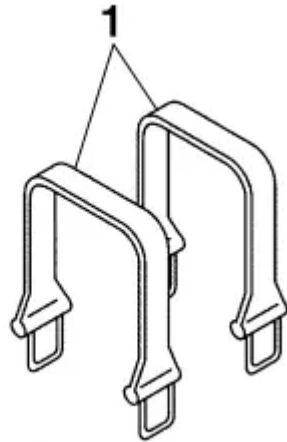

1 Battery band

To store the battery:

- (1) Clean the battery case using fresh water.
- (2) If the battery terminals are dirty or corroded, clean them using a wire brush.

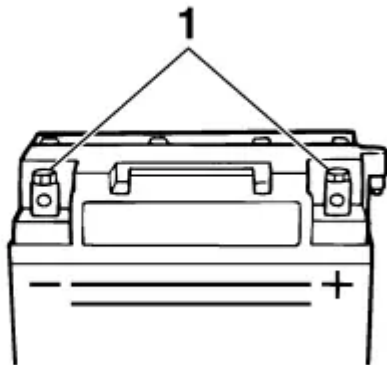

1 Battery terminal

- (3) Apply water-resistant grease to the battery terminals.
- (4) Store the battery in a cool, dry place. **NOTICE:** Storing the battery in an uncharged condition can cause permanent battery damage. Check the battery periodically. [ECJ00103]

To install the battery:

1. Place the battery in the battery compartment and hook the battery bands onto the holders.
2. Connect the positive (+) battery lead (red) to the positive (+) battery terminal. NOTICE: Reversal of the battery leads will damage the electrical parts. [ECJ00262]
3. Connect the negative (-) battery lead (black) to the negative (-) battery terminal.
4. Connect the breather hose to the battery. WARNING! Fire or explosion could result if the breather hose is damaged, obstructed, or not connected properly. [EWJ00452]
5. Make sure that the battery is securely held in place.

Long-term storage

WARNING: Always place the watercraft upright in a horizontal position when storing it, otherwise fuel could leak out into the engine or engine compartment, which could create a fire hazard

Storage for long periods of time, such as winter storage, requires preventive maintenance to ensure against deterioration. It is advisable to have the watercraft serviced by a Yamaha dealer prior to storage.

However, the following procedures can be performed easily by the owner.

Cleaning

(1) Flush the cooling water passages. (See page 86 for information on flushing the cooling water passages.

TIP: If you will be storing the watercraft for a prolonged period, such as winter storage, top off the fuel tank with fresh gasoline and add one ounce of Yamalube Fuel Stabilizer & Conditioner Plus to each gallon of fuel in the fuel tank before starting the engine.

(2) Clean the watercraft. (See page 87 for information on cleaning the watercraft.) Wax the hull with a non-abrasive wax such as Yamalube Professional Polish.

Lubrication

To keep moving parts sliding or rotating smoothly, lubricate them with water-resistant grease.

Recommended water-resistant grease: YAMALUBE MARINE GREASE

- Steering cable (jet thrust nozzle end)

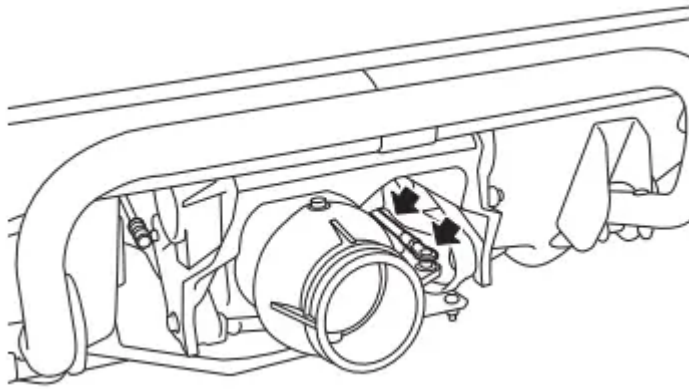

- VX / VX Deluxe / VX Cruiser / VX Limited: Shift rod (reverse gate end) and ball joint

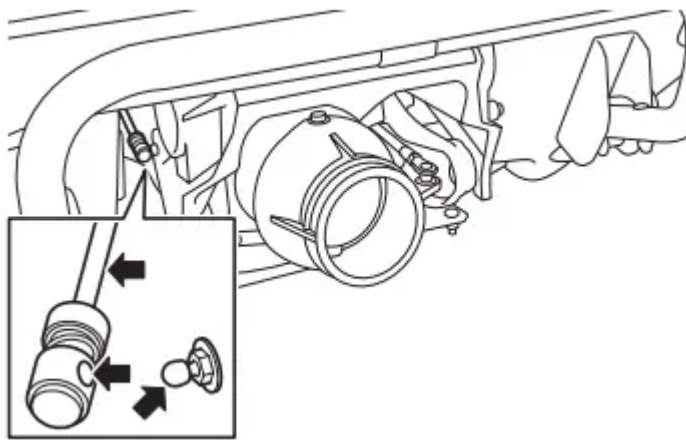

TIP: Disconnect the shift rod from the ball joint before lubricating.

Rustproofing

Rustproofing the hull, deck, and engine Spray metallic parts of the hull, deck, and engine with a rust inhibitor such as Yamalube Silicone Protectant & Lubricant.

Rustproofing the internal engine components Rustproof the internal engine components with a rust inhibitor such as Yamalube StorRite Engine Fogging Oil.

To rustproof the internal engine components:

- (1) Remove the seats. (See page 49 for seat removal and installation procedures.)
- (2) Release the hooks on the port side of the air filter case, and then lift up the air filter case cover. NOTICE: Do not lift up the air filter case cover forcefully. Otherwise, the fuel hose that is secured to the air filter case cover could be damaged. [ECJ02620]

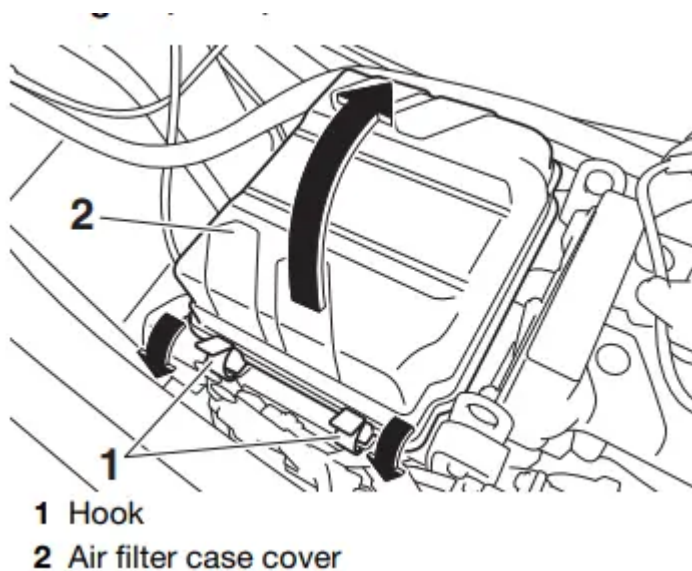

(3) Spray a rust inhibitor such as Yamalube Stor-Rite Engine Fogging Oil into the intake opening for 3 seconds. **WARNING!** Do not spray flammable rust inhibitor products on engine surfaces while the engine is hot. The sprayed substance or propellants could catch fire. [EWJ00262]

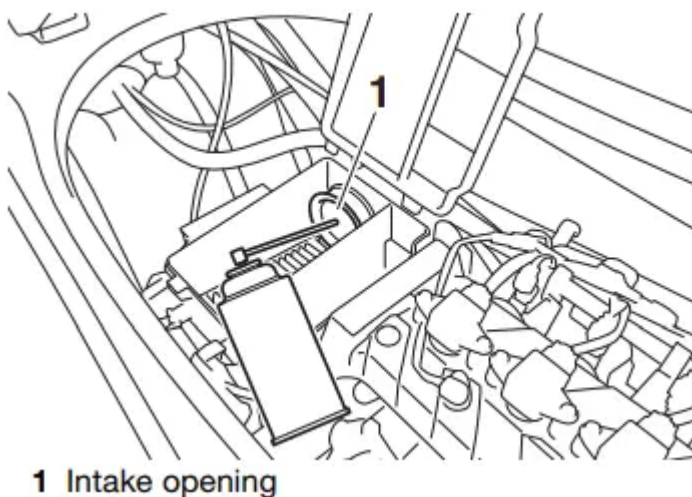

(4) Place the air filter case cover in its original position, and then fit the hooks onto the cover.

TIP: Make sure that the air filter case cover is securely installed.

(5) Make sure that the area around the watercraft is clear, and then start the engine in a well-ventilated area and let it run at idle for 15 seconds. (See page 33 for information on starting the engine.)

(6) Stop the engine.

(7) Securely install the seats in their original positions.

Maintenance

Maintenance

- Periodic checks and lubrication will keep your watercraft in the safest and most efficient condition possible. Therefore, make sure to carry out the periodic maintenance. Safety is an obligation of the watercraft owner. Proper maintenance must be carried out to keep the exhaust emission and sound levels within the regulated limits. The most important points of watercraft inspection and lubrication are explained on the following pages.
- See a Yamaha dealer for genuine Yamaha replacement parts and optional accessories designed for your watercraft.
- Remember, failures that are the result of the installation of parts or accessories which are not qualitatively equivalent to genuine Yamaha parts are not covered by the limited warranty.
- Maintenance, replacement, or repair of the emission control devices and system may be performed by any marine SI engine repair establishment or individual. Warranty repair, however, must be performed at an authorized Yamaha marine dealership.

WARNING: Be sure to turn off the engine when you perform maintenance unless otherwise specified. If you are not familiar with machine servicing, this work should be done by a Yamaha dealer or other qualified mechanic.

- A service manual is available for purchase through a Yamaha dealer for owners who have the mechanical skills, tools, and other equipment necessary to perform maintenance not covered by this owner's/operator's manual.

Tool kit

- A tool kit is included with this watercraft. Place the tool kit in a waterproof bag and always carry it with you whenever you use the watercraft.

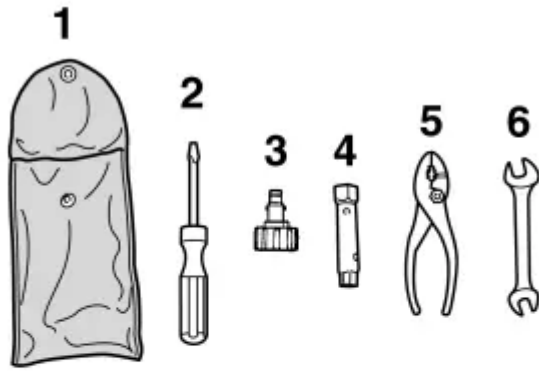

- 1 Tool bag
- 2 Screwdriver
- 3 Garden hose adapter
- 4 10/12 mm box wrench
- 5 Pliers
- 6 10/12 mm open-end wrench

Periodic maintenance chart

- The periodic maintenance chart gives general guidelines for periodic maintenance. Have a Yamaha dealer perform the checks in the following chart. However, maintenance may need to be performed more frequently depending on your operating conditions. If you have any questions, consult a Yamaha dealer.
- This “√” mark indicates items to be checked and serviced by a Yamaha dealer.

Item	Operation	Initial	Thereafter every			Page
		10 hours	50 hours or 12 months *1	100 hours or 12 months *1	200 hours or 24 months *1	
Fuel line	Check fuel hoses and clamps			√		—
Fuel filler cap/Water separator	Check O-rings for cracks and deformation			√		—
Fuel tank	Check installation and straps			√		—
Water inlet strainer	Check for clogs and damage			√		—
Cooling water hoses	Check for damage and leakage, and check clamps			√		—
Engine oil	Replace	√		√		95
Oil filter	Replace			√		95
Intermediate housing	Lubricate			√		—
Spark plugs	Check	√		√		—
Battery	Check state of charge, terminals, bands, and breather hose			√		—
Battery leads	Check terminals			√		—
Steering master	Check operation and for looseness	√		√		—
Steering cable	Check exterior and connections, and lubricate			√		—
Shift rod and reverse gate (VX / VX Deluxe / VX Cruiser / VX Limited)	Check exterior and connections, and lubricate			√		—
Air filter element	Check for damage and dirt			√		—
Air intake hoses	Check for damage, and check clamps			√		—



Item	Operation	Initial	Thereafter every			Page
		10 hours	50 hours or 12 months *1	100 hours or 12 months *1	200 hours or 24 months *1	
Throttle body	Lubricate throttle valve			√		—
Exhaust system	Check for exhaust leakage, and check hoses and clamps			√		—
Breather hose	Check breather hose and clamps			√		—
Impeller	Check for bends, damage, and foreign material			√		—
Jet thrust nozzle	Check movement, and lubricate			√		—
Jet vacuum bilge	Check hoses for clogs and damage, check clamps, and clean bilge strainer			√		—
Stern drain plugs	Check O-rings			√		—
Anode	Check for corrosion, and clean				√ *2	—
Valve clearance	Check and adjust				√ *2	—
Rubber coupling	Check for cracks, indentations, looseness, and noise				√	—
Engine mount	Check for damage and peeling				√	—

*1: Whichever comes first.

*2: Check every 200 hours.

Perform the pre-operation checks and post-operation checks before performing periodic maintenance.

Engine oil and oil filter

WARNING: Engine oil is extremely hot immediately after the engine is turned off. Coming in contact with or getting any engine oil on your clothes could result in burns.

NOTICE: Do not run the engine with too much or not enough oil in the engine, otherwise the engine could be damaged.

- It is recommended to have a Yamaha dealer change the engine oil and the engine oil filter. However, if you choose to change the oil and filter on your own, consult a Yamaha dealer.

Trouble recovery

Troubleshooting

If you have any trouble with your watercraft, use the troubleshooting chart to check for the possible cause.

If you cannot find the cause, consult a Yamaha dealer.

Troubleshooting chart

Confirm the possible cause and remedy, and then refer to the applicable page.



TROUBLE	POSSIBLE CAUSE		REMEDY	PAGE
Engine does not start (Starter motor does not turn over)	Yamaha Security System (VX Deluxe / VX Cruiser / VX Limited)	Lock mode selected	Select unlock mode	32
	Engine shutoff switch	Clip not in place	Install clip	33
	Fuse	Burned out	Have serviced by Yamaha dealer	-
	Battery	Run down	Recharge	87
		Poor terminal connections	Tighten as required	87
		Terminal corroded	Clean or replace	87
	Starter moto	Faulty	Have serviced by Yamaha dealer	-
Engine does not start (Starter motor turns over)	Throttle lever	Squeezed	Release	33
		Faulty	Have serviced by Yamaha dealer	-
	Fuel	Fuel tank empty	Refill as soon as possible	56
		Stale or contaminated	Have serviced by Yamaha dealer	-

	Fuel tank	Water or dirt present	Have serviced by Yamaha dealer	-	
	Spark plug	Fouled or defective	Have serviced by Yamaha dealer	-	
	Fuel injection system	Fuel pump faulty	Have serviced by Yamaha dealer	-	
Engine runs irregularly or stalls	Fuel	Fuel tank empty	Refill as soon as possible	56	
		Stale or contaminated	Have serviced by Yamaha dealer	-	
	Fuel tank	Water or dirt present	Have serviced by Yamaha dealer	-	
	Spark plug	Fouled or defective	Have serviced by Yamaha dealer	-	
		Incorrect heat range	Have serviced by Yamaha dealer	-	
		Gap incorrect	Have serviced by Yamaha dealer	-	
	Electrical wiring	Loose connection	Have serviced by Yamaha dealer	-	
	Fuel injection system	Faulty or clogged injectors	Have serviced by Yamaha dealer	-	
			Fuel tank empty		56

Warning light or indicator blinks or comes on	Fuel level warning		Refill as soon as possible	
	Oil pressure warning	Oil pressure dropped	Have serviced by Yamaha dealer	46
	Engine overheat warning	Jet intake clogged	Clean	100
	Check engine warning	Faulty sensors	Have serviced by Yamaha dealer	47
Watercraft slow or loses power	Watercraft operation mode (VX Deluxe / VX Cruiser / VX Limited)	Low RPM Mode activated	Deactivate Low RPM Mode	39
	Cavitation	Jet intake clogged	Clean	100
		Impeller damaged or worn	Have serviced by Yamaha dealer	100
	Engine overheat warning	Engine speed reduction control activated	Clean jet intake and cool engine	46
	Oil pressure warning	Engine speed reduction control activated	Add oil	46
	Spark plug	Fouled or defective	Have serviced by Yamaha dealer	-
		Incorrect heat range		-



			Have serviced by Yamaha dealer	
		Gap incorrect	Have serviced by Yamaha dealer	-
	Electrical wiring	Loose connection	Have serviced by Yamaha dealer	-
	Fuel	Stale or contaminated	Have serviced by Yamaha dealer	-
	Air filter	Clogged	Have serviced by Yamaha dealer	-
		Oil buildup	Have serviced by Yamaha dealer	-
	Throttle lever	Faulty	Have serviced by Yamaha dealer	-

Emergency procedures

Cleaning the jet intake and impeller

WARNING: Before attempting to remove weeds or debris from the jet intake or impeller area, shut the engine off and remove the clip from the engine shut-off switch. Severe injury or death could result from coming in contact with the rotating parts of the jet pump.

- If weeds or debris gets caught in the jet intake or impeller, cavitation can occur, causing jet thrust to decrease even though engine speed rises. If this condition is allowed to continue, the engine will overheat and may seize.

NOTICE: If weeds or debris gets caught in the jet intake, do not operate the watercraft above trolling speed until they have been removed. [ECJ00654]

- If there is any sign that the jet intake or impeller is clogged with weeds or debris, return to shore and check the intake and impeller. Always stop the engine before beaching the watercraft.

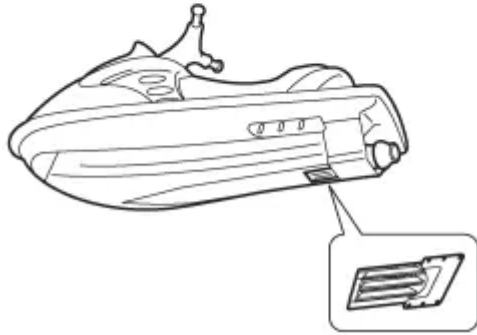
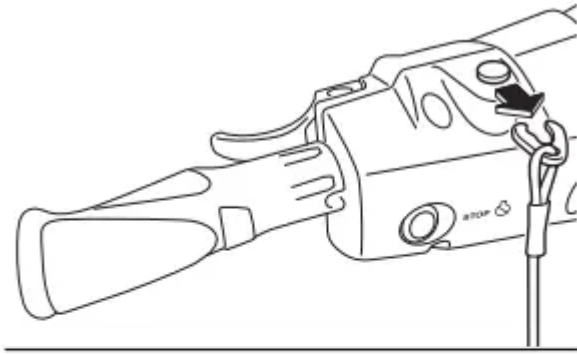

(1) Place a suitable clean cloth or carpeting underneath the watercraft to protect it from abrasions and scratches. Turn the watercraft on its side as shown. NOTICE: When turning the watercraft on its side, support the bow so that the handlebars are not bent or damaged. [ECJ02690]

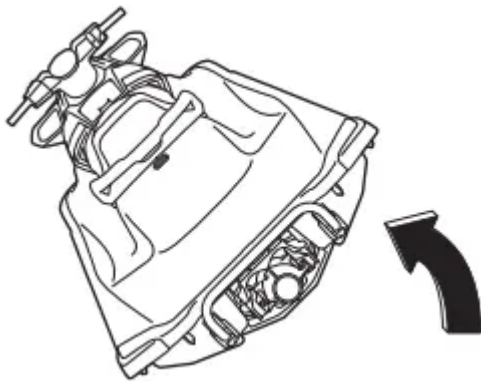

(2) Remove any weeds or debris from around the jet intake, drive shaft, impeller, jet pump housing, and jet thrust nozzle. If debris is difficult to remove, consult a Yamaha dealer.

Raising the reverse gate (VX / VX Deluxe / VX Cruiser / VX Limited)

- If the RiDE system malfunctions and the reverse gate remains in the lowered position, the watercraft will not be able to move forward.
- After raising the reverse gate so that the watercraft can move forward, immediately return to shore and have a Yamaha dealer service the watercraft.

To raise the reverse gate:

- (1) Stop the engine and remove the clip from the engine shut-off switch.
- (2) Enter the water and move to the rear of the watercraft.
- (3) Slide the shift rod joint toward the bow, and then disconnect the shift rod joint from the ball joint.

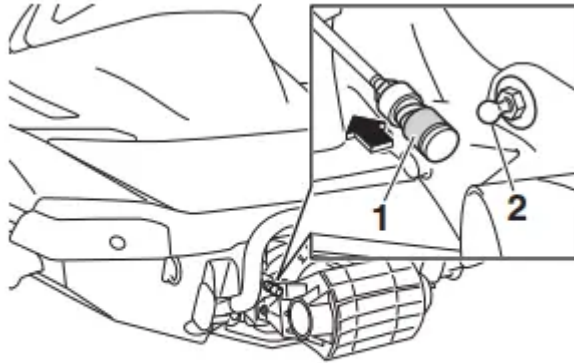

1 Shift rod joint
2 Ball joint

- (4) Raise the reverse gate to the forward position.

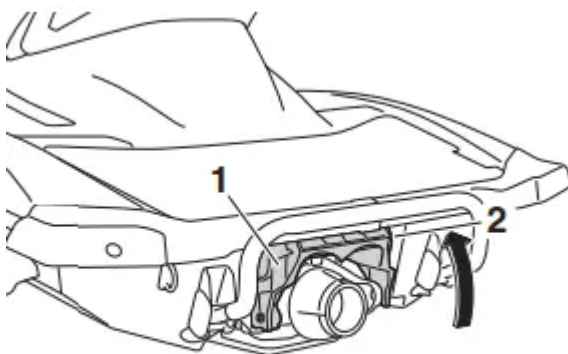

1 Reverse gate
2 Forward position

TIP:

- While the shift rod is disconnected, the reverse gate will not move to the neutral position or reverse position even if the RiDE lever is squeezed.
- If the RiDE lever is squeezed while the shift rod is disconnected, the watercraft will move forward.

Jumping the battery

If the watercraft battery has run down, the engine can be started using a 12-volt booster battery and jumper cables.

Connecting the jumper cables

WARNING: To avoid battery explosion and serious damage to the electrical system:

- Do not reverse the polarity of the jumper cables when connecting to the batteries.
- Do not connect the negative (-) jumper cable to the negative (-) terminal of the watercraft battery.
- Do not touch the positive (+) jumper cable to the negative (-) jumper cable.

(1) Connect the positive (+) jumper cable to the positive (+) battery terminals of both batteries.

(2) Connect one end of the negative (-) jumper cable to the negative (-) battery terminal of the booster battery.

(3) Connect the other end of the negative (-) jumper cable to an engine hanger

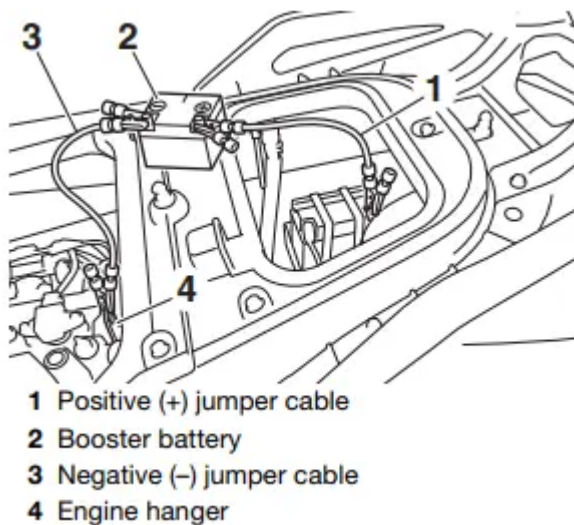

4) Start the engine, and then disconnect the jumper cables by reversing the steps above.
(See page 33 for information on starting the engine.)

Towing the watercraft

WARNING

- The operator of the towing boat must keep speed to a minimum and avoid traffic or obstacles which could be a hazard to the operator on the watercraft.
- The towline should be long enough so that the watercraft will not collide with the towing boat when slowing down.

If the watercraft becomes inoperative in the water, it can be towed to shore.

To tow the watercraft:

Use a towline that is three times the combined length of the towing boat and the watercraft.

(1) Securely attach the towline to the bow eye of the watercraft being towed.

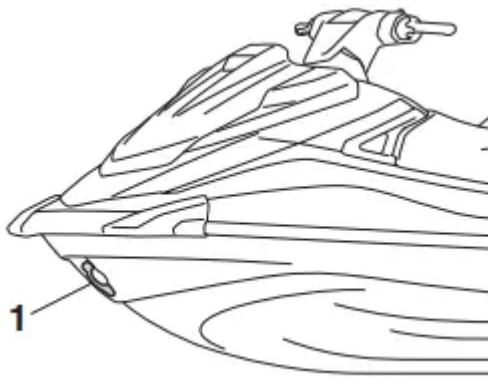

1 Bow eye

(2) Sit astride the seat and hold on to the handlebars in order to balance the watercraft.
NOTICE: The bow must be kept up out of the water during towing, otherwise water could flood the engine compartment or water could flow back into the engine, causing severe engine damage. [ECJ01331]

Tow the watercraft at 8 km/h (5 mph) or less.

NOTICE: Tow the watercraft at 8 km/h (5 mph) or less, otherwise water could flood the engine compartment or water could flow back into the engine, causing severe engine damage.
[ECJ01322]

Submerged watercraft

If the watercraft is submerged or flooded with water, drain the bilge water from the engine compartment. Then, have a Yamaha dealer service the watercraft as soon as possible.

If the watercraft was submerged:

- (1) Remove the watercraft from the water and drain the water from the storage compartments. (See page 52 for information on draining the storage compartments.)
- (2) Drain the bilge water from the engine compartment. (See page 60 for information on draining the bilge water.)
- (3) Have the watercraft serviced by a Yamaha dealer as soon as possible.

NOTICE: Be sure to have a Yamaha dealer inspect the watercraft. Otherwise, serious engine damage could result. [ECJ00792]

Warning

This content is compiled from multiple sources and is provided for reference purposes only. It may not be complete or fully applicable to all situations. If you are unable to resolve your issue, please contact the product manufacturer or an authorized service provider for official support.