

Appliance description

Oven interior and accessories

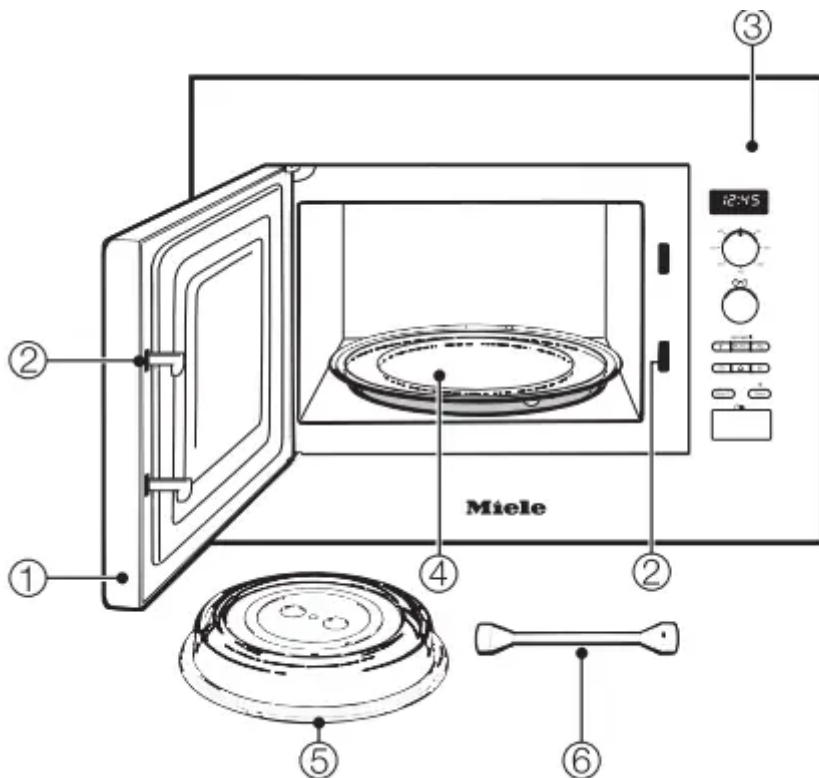

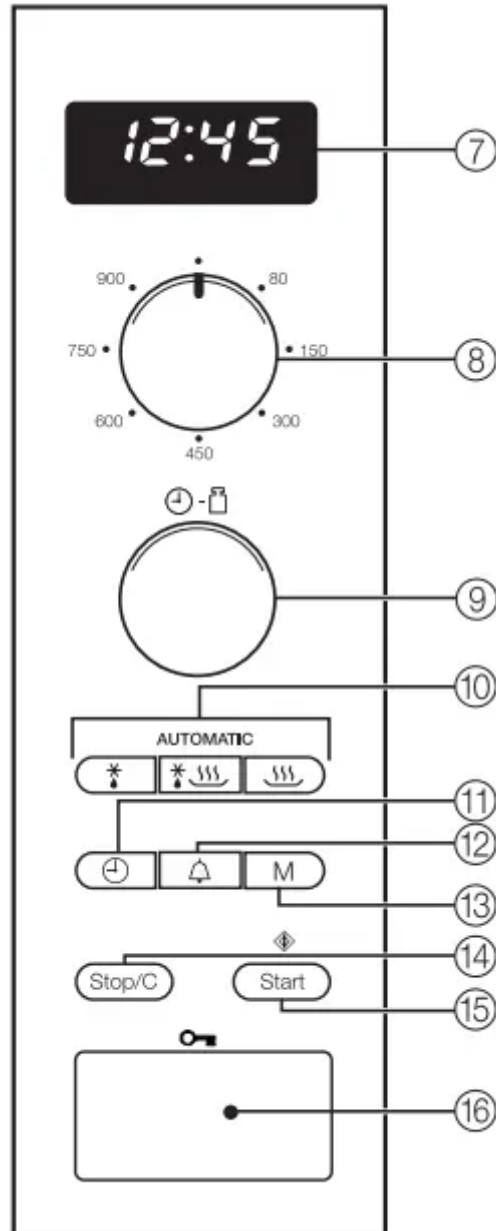

Control panel



1. Oven door
2. Door locking mechanism
3. Control panel
4. Turntable
5. Plate cover
6. Boiling stick
7. Clock/Timer display
8. Selector knob for microwave power
9. Selector knob for entering time and weight

10. Automatic program buttons

11.  Clock button

12.  Timer button

13. Memory button (for saving a 1- to 3- stage program sequence)

14. Stop/Cancel button

15.  Start / Add one minute / Minute + button (programmable)

16.  Door release

Included accessories

Plate cover

The cover supplied must only be used in the Microwave Solo mode.

It prevents food from drying out and the oven interior from becoming dirty, and it accelerates the heating process.

Boiling stick

When heating liquids, the boiling stick should always be placed in the container. It helps heat liquids evenly.

These products and other useful accessories can be ordered via the Miele website or from your Miele dealer.

Before first use

Allow the microwave to sit unpacked for approx. 2 hours after transport before using it for the first time.

During this time, the temperature of the appliance can equalize with the room temperature. This is important for the correct electronic functioning of the appliance.

WARNING: Danger of suffocation! Ensure that any plastic wrapping, bags, etc. are disposed of safely and kept out of the reach of children.

- Remove all packaging material when unpacking the appliance.

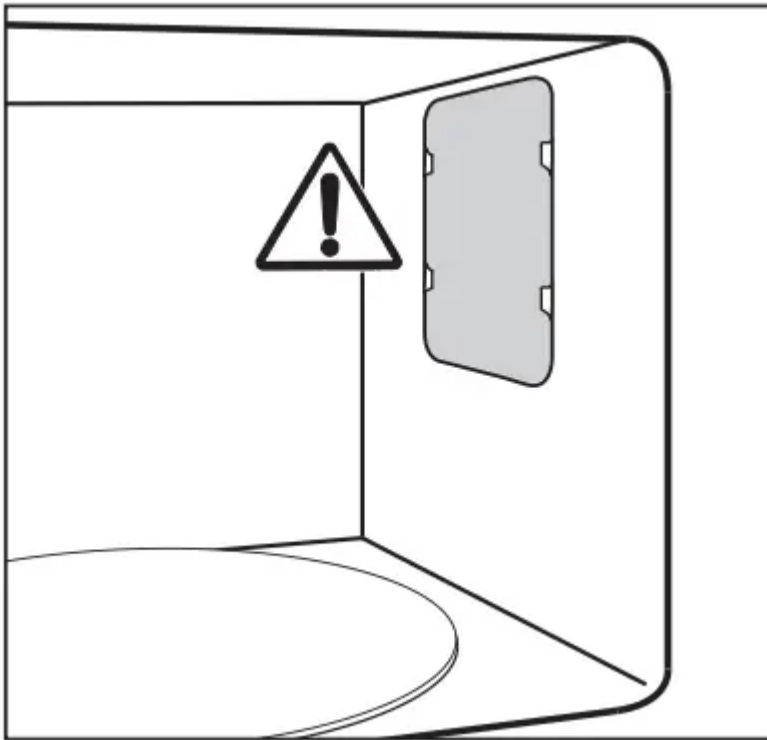

Do not remove the plate cover to the microwave outlet in the oven interior or the film that covers the inside of the door.

- Check the appliance for any damage.

Do not use the microwave oven if:

- The door is warped.
- The door hinges are loose.
- Holes or cracks are visible on the casing.

Operating the appliance with this type of damage will result in microwave leakage and pose a danger to the user.

- Clean the oven interior and all accessories with a soft sponge and warm water.

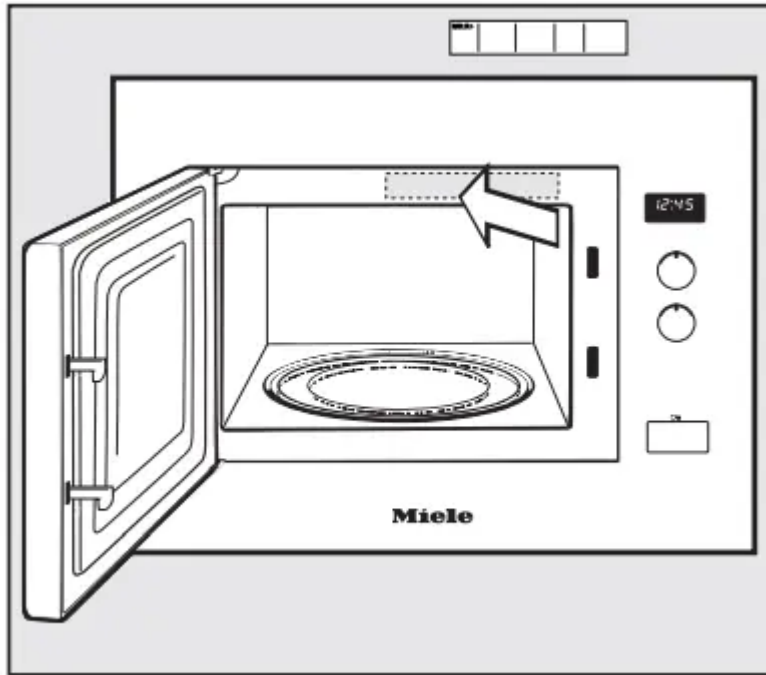

- Place the enclosed quick guide to the frame behind the door (as illustrated), making sure they do not block any of the vents.

Clock display

WARNING: The microwave oven may not be operated until it has been properly installed in a cabinet.



Setting the clock

- Connect the appliance to the power supply.



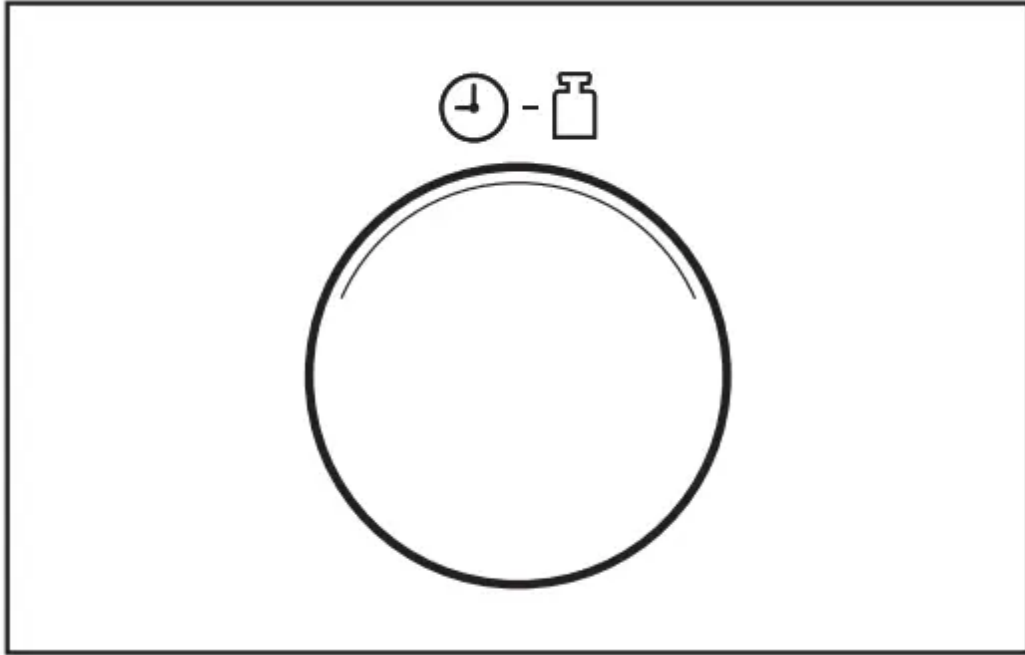

"12:00" and the  symbol will flash in the display until the current time of day is set. Until then, the clock counts upwards from 12:00, since it starts as soon as the appliance

is connected to the power supply.





- Turn the selector knob to set the hour.
- Press the  button
- Then, turn the selector knob to set the minutes.
- Press the  button to confirm the selection, or wait a few seconds. The new time setting is then applied. The colon between hours and minutes will flash.

Resetting the clock

- Press the  button. The  symbol will flash in the display and the current hour will light up for a few seconds.
- Use the selector knob to change the hour.
- Press the  button to confirm the selection, or wait a few seconds. The  symbol will flash and the current minute setting will light up for a few seconds.
- Use the selector knob to change the minutes.
- Press the  button to confirm the selection, or wait a few seconds.

Turning off the clock display

- Press and hold the  button until the display goes dark.
- Pressing and holding in the  button again to display the clock again.

Operation

Opening the door

- Press the  button to open the door.

If the microwave oven is in use, opening the door will interrupt the current program.

Placing dishes in the microwave

Ideally, the dish should be placed in the middle of the oven interior.

Turntable

The turntable helps the food to cook, reheat or defrost evenly.

Do not operate the microwave without the turntable in place.

The turntable begins turning automatically when a program is started.

Do not cook, reheat or defrost food directly on the turntable. Check that the dish is not larger in size than the turntable.

Turn or stir food during cooking, or turn the dish, so that it heats up evenly.

Closing the door

- Push the door shut. If the door was opened while the microwave was in use, press the Start button to resume the interrupted program.

The appliance will not start again if the door has not been closed properly.

Starting a program

Use the appropriate selector to choose the microwave power level and the cooking time.

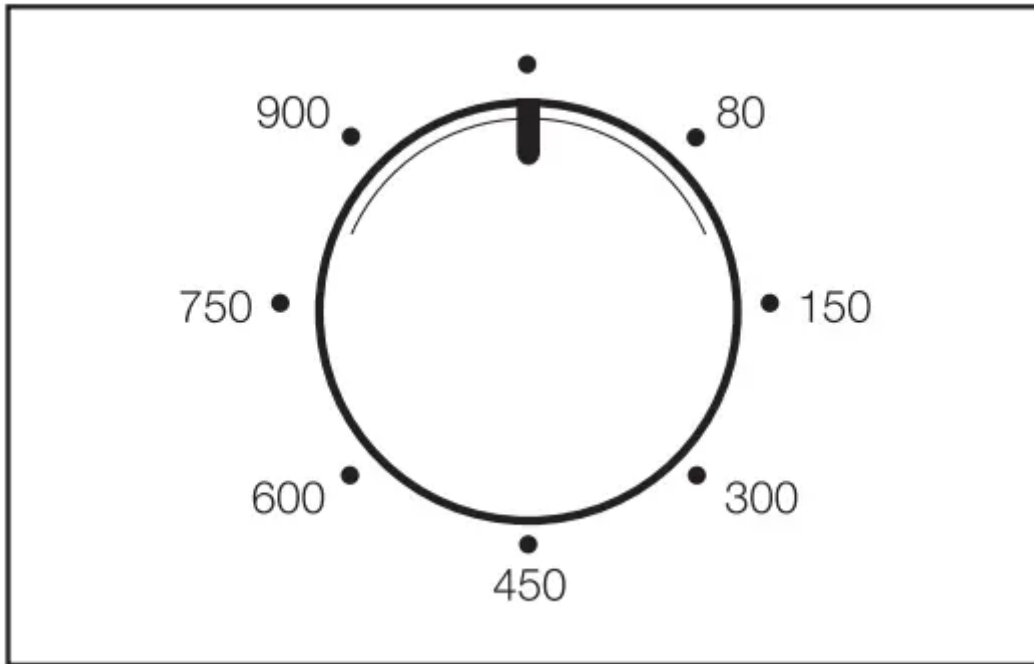

Use the power selector to choose the desired power level.

The  symbol and the power level selected will appear in the display. "0:00" will flash.

You can choose from 7 different power levels. The higher the power level, the more microwaves reach the food.

When heating up foods that cannot be stirred or turned during cooking, or foods with very different consistencies, it is best to use a lower microwave power level.

This ensures the heat is distributed evenly. Heat for long enough to cook the food properly.

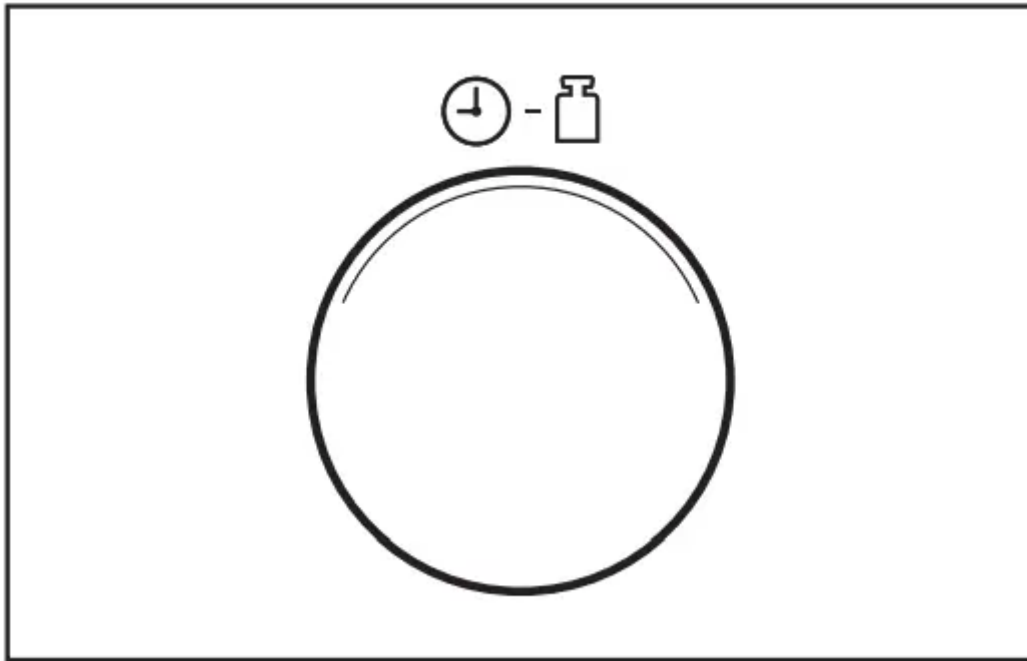

- Set the required time using the selector knob.

You can choose any length of time between 10 seconds and 90 minutes. Exception: If the maximum power level is selected, you can set a time of up to 15 minutes. If you continue to cook at full power, the machine will automatically decrease to a 600 W power level to protect from overheating (indicated in the display).

The time required depends on:

- The initial temperature of the food. Food taken from the refrigerator will need longer to reheat, cook, etc. than food already at room temperature.
- The type and texture of the food. Fresh vegetables contain more water and cook more quickly than stored vegetables.
- The frequency with which the food is stirred or turned. Frequent stirring or turning heats the food more evenly, and it is therefore ready in less time.
- The amount of food.

As a general rule: Double the quantity = nearly twice the time

For a smaller quantity of food, the cook time decreases proportionately.

- The shape and material of the dishware.

- Press the Start button to start the program. The interior lighting comes on.

A program can only be started if the door is closed.

"Door" message

The "Door" message in the display is a reminder that the appliance cannot be used without food inside it.

Operating the microwave without food can damage the appliance.

If the door has been closed for 20 minutes or longer when the Start button is pressed, the word door will appear in the display to remind you to open the door and make sure there is food in the appliance before you press Start. You cannot start a program until you do this.

Interrupting or resuming a program

At any time you can...

... interrupt a program:

- Press the "Stop/C" button, or open the appliance door.

The time stops counting down.

... resume a program:

- Close the door and press the "Start" button.
The program will continue.

Changing the settings

After starting the program, if you determine that...

. . . the microwave power level is too high or too low:

- Select a new power level.

. . . the time entered is too short or too long:

- Interrupt the program (press the "Stop/C" button once), use the selector knob to set a new time, and resume the program (press the "Start" button),

or alternatively:

- Press the "Start" button during operation to increase the cooking time. Each push of the button increases the time by another minute. (Exception: The time increases by 30 seconds when the microwave oven is being used at maximum power.)

Cancelling a program

- Press the "Stop/C" button twice.

At the end of a program

An signal will sound when the cooking program is complete. The oven interior lighting goes out.

As a reminder, the signal will sound briefly every 5 minutes for 20 minutes once the program is complete.

- If you wish to stop the signal, press the "Stop/C" button.

Automatic "Keep warm" function

The automatic keep-warm function will turn on automatically at 80 W for a maximum of 15 minutes approx. 2 minutes after the end of a cooking program that was run at a power level of least 450 W, provided that the door remains closed and no buttons are pressed.



80 W and H:H will appear in the display.

Opening the door or operating one of the buttons or selectors while the automatic keep-warm function is in progress will cancel the function.

The automatic keep-warm function cannot be set as a separate function.

Minute + (programmable)

Pressing the "Start /  " button is sufficient to start the appliance operating at maximum power. Three cooking times are stored in the memory:



- 30 sec: Press "Start /  " once
- 1 min: Press "Start /  " twice
- 2 min: Press "Start /  " three times

Pressing "Start /  " four times in a row will return you to the first saved time, etc.

The cooking time can be increased during operation by pressing the "Start" button. Each time the "Start" button is pressed, the duration is increased by another 30 seconds.

Reprogramming saved times

You can change the saved cooking times.

Use the "Start /  " button to select the time you wish to reprogram (press once, twice or three times) and hold the "Start /  " button.

While holding the "Start" button, change the time using the selector knob (max. 15 minutes). The

modified program will run when the "Start /  " button is released.

If there is a loss of power, the reprogrammed times will no longer be saved and must be reset.

System lock

The system lock prevents unauthorized operation of the appliance.

To activate the system lock

- Press and hold the "Stop/C" button until a signal sounds and the key symbol appears in the display:



The key symbol will go out after a short time.

The key symbol will reappear whenever a button is pressed or a selector is turned.





If there is a power outage, the system lock will need to be reactivated.

To deactivate the system lock

- If you would like to deactivate the system lock, press and hold the "Stop/C" button again until a signal sounds.

Timer

The timer can be used to keep track of other activities in the kitchen, e.g. boiling eggs. The time set counts down in one-second increments.

- Press the  button. "00:00" flashes in the display and the  symbol appears.
- Set the desired time using the selector knob.
- Press the "Start" button to start the timer. It will also start on its own after a few seconds if the "Start" button is not pressed.
- When the set time has elapsed, a signal sounds, the clock appears, and the  symbol flashes.
- Press the "Stop/C" button once and the  symbol disappears.



Reprogramming the timer

- Press the "Stop/C" button. The current timer countdown is interrupted.

- Set a new timer duration as described above.

Timer + Cooking Program

The timer can be used at the same time as a cooking program and will count down in the background.

- Press the  button while the program is in progress. "00:00" flashes in the display and the  symbol appears.
- Set the desired time using the selector knob.
- After a few seconds the timer will begin to count down. A few seconds after this, the display will change again to show the current cooking time counting down. The  symbol indicates that the time is counting down in the background.

Do not press the "Start" button to start the timer in this case. This will increase the duration of the current cooking program by one minute.

Remaining time

- Press the  button. The remaining time on the timer will show in the display

All automatic programs are weight dependent.

The weight can be displayed in either pounds (lb) or grams (g), see "Settings".

Once a program is selected, enter the weight of the food. The microwave then automatically calculated the time according to the weight entered.

When cooking is complete, allow the food to stand at room temperature for the suggested "standing time" to allow the heat to distribute evenly throughout the food.

Automatic defrosting

Five programs are available for defrosting different types of food .

The recommended "standing time" for Ad 3 is up to 30 minutes depending on the weight. Approx. 10 minutes is recommended for the remaining programs.

Ad 1  Steak, cutlets
(0.5 – 2.2 lb)/(200 – 1000 g)

Ad 2  Ground meat
(0.5 – 2.2 lb)/(200 – 1000 g)

Ad 3  Chicken
(2.0 – 4.0 lb)/(900 – 1800 g)

Ad 4  Cakes
(0.3 – 3.1 lb)/(100 – 1400 g)

Ad 5  Bread
(0.5 – 2.2 lb)/(200 – 1000 g)

Automatic cooking

Three programs are available for frozen and fresh food.

The recommended "standing time" for these programs is approx. 2 minutes.

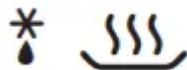

Cooking frozen food

AC 1  Vegetables
(0.3 – 1.3 lb)/(100 – 600 g)

AC 2  Frozen dinner (can be stirred)
(0.7 – 2.2 lb)/(300 – 1000 g)

AC 3  Casseroles
(0.5 – 1.3 lb)/(200 – 600 g)

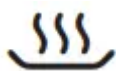

Cooking fresh food

AC 1  Vegetables
(0.3 – 1.3 lb)/(100 – 600 g)

AC 2  Potatoes
(0.3 – 1.7 lb)/(100 – 800 g)

AC 3  Fish
(1.2 – 3.3 lb)/(500 – 1500 g)

AC 4  Popcorn
(0.06 – 0.22 lb)/(30 – 100 g)

Automatic programs

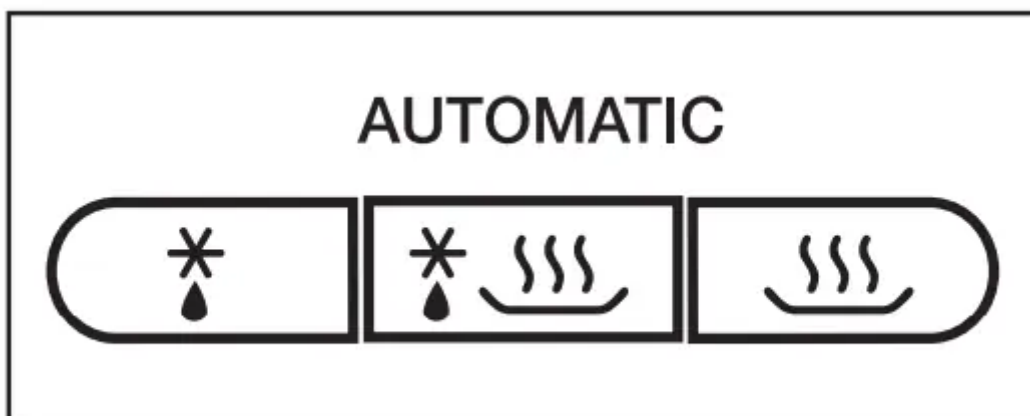

- Press the relevant button until the desired program appears in the display.

Example: To select program Ad 3  (defrosting chicken) press "  " three times.

lb or g will flash in the display, and the selected program will light up along with the Microwave symbol "  ".

- If desired press "M", to toggle between the lb and g settings.
- Enter the weight using the "Weight selector".
- Press "Start".

The cooking duration, which was calculated according to the weight entered, will be counted down and the Microwave symbol  will light up.

A signal will sound halfway through the cooking time.

- Interrupt the program to turn or stir the food then continue the program.

If desired the time can be extended by a few minutes during operating by pressing the "Start" button repeatedly until the desired time shows in the display.

It is only possible to extend the time by a few minutes.

A signal will sound when the program is complete, and the interior lighting of the microwave will go out.



Popcorn

This automatic programme is suitable for making microwave popcorn.

The programme is not suitable for making popcorn from kernels. Only use this automatic programme for popcorn which is specifically labelled as microwave popcorn.

- Place the packet on the turntable according to the instructions on the packaging.

Ensure that the bag can inflate freely. A build-up of heat could be caused by the bag touching the interior wall and becoming stuck.

- Stop the programme before the end if the popping noises become infrequent. Follow the instructions on the packaging.

The bag will be very hot. Remove it with care.

Reheating

Select the following microwave power levels to reheat food and drinks:

Drinks 900 W

Food 600 W

Food for babies and toddlers . . . 450 W

WARNING: Be sure that baby/toddler food does not become too hot. Heat for only 1/2 to 1 minute at 450 W.

Tips for reheating

Always use a lid or plate cover for reheating food, except when a drier finish is desired, e.g. breaded poultry/ meat.

WARNING:

Always remove the lids from jars, especially jars of baby food. Remove the screw cap and nipple before warming baby bottles.

When reheating liquids, place the boiling stick supplied with the appliance into the cup or glass.

Never reheat hard boiled eggs in a microwave oven, even without the shell. The eggs can explode.

Food taken straight from the refrigerator will take longer to reheat than food stored at room temperature. The cooking time required depends on the texture of the food, its initial temperature and the amount to be cooked.

Always ensure that food is sufficiently reheated.

If you are unsure whether a sufficiently high temperature has been reached, continue reheating a little longer.

Larger amounts of food should be stirred or turned from time to time during cooking. Stir the food from the outside towards the middle, as food heats more quickly from the outside.

After reheating

Be careful when removing dishes from the appliance. They may be hot.

Although heat is not normally produced in the cookware itself by the microwaves (apart from stoneware), heat is transferred from the food to the container, which can cause the container to become hot.

Allow food to stand at room temperature for a few minutes after reheating so that the heat can spread evenly throughout the food and so that a consistent temperature is reached.

WARNING: After reheating food/drinks, especially for babies and small children, stir it or shake the container and check that the temperature does not pose any danger.

Cooking

Place the food in microwave-safe cookware and cover it.

When cooking, it is recommended to initially select a power level of 900 W and then, when the food is hot, reduce the power level to 450 W for a more gentle continued cooking.

For dishes such as rice or pudding, first select a power level of 900 W, and then reduce it to 150 W for simmering.

Tips for cooking

The cooking time for vegetables depends on their texture. Fresh vegetables contain more water than vegetables which have been stored and usually cook more quickly. Add a little water to vegetables which have been kept stored.

Food taken straight from the refrigerator will take longer to cook than food which has been kept at room temperature.

Stir or turn food from time to time during cooking to help it cook more evenly.

Ensure that foods which spoil quickly, such as fish, are thoroughly cooked for an appropriate length of time.

Food with a thick skin or peel, such as tomatoes, sausages, potatoes (cooked in their skins) and eggplant, should be pierced or the skin cut in several places before cooking to allow steam to escape and prevent the food from bursting.

When cooking eggs in their shells in the microwave oven, you must use a specially designed egg boiler. Otherwise, the eggs will explode, even after being removed from the oven interior.

Eggs can be cooked without their shells in the microwave oven only if the yolk membrane has been punctured several times first. The pressure could otherwise cause the egg yolk to explode.

After cooking

Be careful when removing dishes from the appliance. They may be hot.

Although heat is not normally produced in the cookware itself by the microwaves (apart from stoneware), heat is transferred from the food to the container, which can cause the cookware to become hot.

Allow food to stand at room temperature for a few minutes (standing time) after cooking so that the heat can spread evenly throughout the food and so that a consistent temperature is reached.

Defrosting / Defrosting and reheating or cooking

Do not refreeze partially or fully defrosted food. Consume defrosted food as soon as possible, as it will lose its nutritional value and spoil if left for too long. Defrosted food may only be refrozen after it has been cooked.

Defrost

Select the following microwave power settings to defrost food:

- 80 W for defrosting very delicate food, such as cream, butter, cream cakes and cheese.
- 150 W for defrosting all other foods.

Remove the frozen food from its packaging and place in a microwavesafe container. Do not cover. Turn, stir or separate the food about halfway through the defrosting time.

To defrost meat, unpack the frozen meat and place it on an overturned plate in a glass or porcelain container so that the meat juice can drip off and be collected. Turn from time to time during defrosting.

When defrosting poultry, be sure to strictly observe food hygiene rules. Do not use the liquid from the defrosted poultry.

Risk of salmonella poisoning! Always follow USDA guidelines on food safety.

Defrosting followed by reheating or cooking

Deep-frozen food can be defrosted and immediately reheated or cooked.

After defrosting, select 900 W and then 450 W.

Remove the food from its packaging and place in a covered microwave-safe container for defrosting and reheating or cooking. Exception: Ground beef should be left uncovered while cooking.

Foods containing large amounts of liquid, such as soups and vegetables, should be stirred several times during the process. Carefully separate and turn slices of meat halfway through. Turn pieces of fish at the halfway mark.

After defrosting followed by reheating or cooking

Allow the food to stand at room temperature for a few minutes so that the heat can spread evenly throughout the food.

Canning

You can use the microwave to can small amounts of fruit, vegetables and meat in glass jars. Prepare the items as you normally would.

Do not fill the jars more than 1" (2.5 cm) below the rim.

Only use clear adhesive tape or microwave-safe clips to close the jars.

Never use metal clips or jars with screw-on lids.

Do not use metal cans. When cans are used, excess pressure is produced which may cause the cans to explode. Risk of injury and damage!

For best results, use no more than four 1 pint (1/2 - -liter) jars at a time when canning. Place the jars on the turntable.

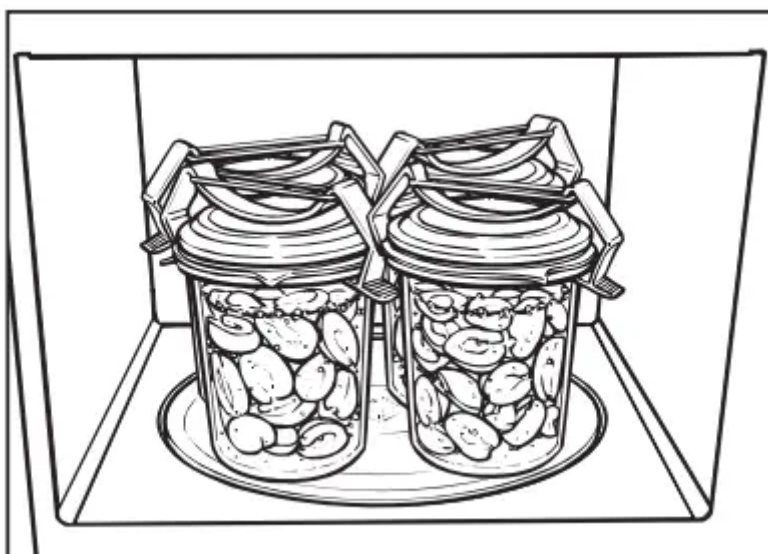

Set the power level to 900 W and bring the jar contents to a boil. The amount of time required for this depends on:

- The initial temperature of the contents.
- The number of jars.

The amount of time required for the contents in all jars to start bubbling evenly is as follows:

1 jar. approx. 3 minutes

2 jars approx. 6 minutes

3 jars approx. 9 minutes

4 jars approx. 12 minutes

This is enough time for canning fruit and cucumbers.

For vegetables, reduce the power to 450 W once the contents start bubbling.

Cook

- Carrots for approx. 15 minutes
- Peas for approx. 25 minutes.

After canning

Remove jars from the oven interior, cover with a towel and leave to set in a location protected from drafts for approx. 24 hours.

Remove the clips or the adhesive tape and make sure that all glasses are sealed properly



Suggested uses

Food	Quantity	Power level (in W)	Time (min)	Notes
Melting butter	1/4 lb (100 g)	450	1:00 – 1:10	Do not cover.
Melting chocolate	1/4 lb (100 g)	450	3:00 – 3:30	Do not cover. Stir halfway through melting.
Dissolving gelatin	1 packet + 5 tbsp water	450	00:10 – 00:30	Do not cover. Stir halfway through dissolving.
Preparing flan topping/fruit glaze	1 packet + 1 cup (250 ml) liquid	450	4 – 5	Do not cover. Stir halfway through heating.
Yeast dough	Starter made with 1/2 cup (100 g) flour	80	3 – 5	Cover and leave to proof.
Popcorn	1 tbsp (20 g) popcorn	900	3 – 4	Place popcorn in a 1-liter container, cover and cook. Sprinkle with sugar or salt after cooking.
Chocolate marshmallows	3/4 oz (20 g)	600	00:10 – 00:20	Place on a plate, do not cover.
Salad dressings	1/2 cup (125 ml)	150	1 – 2	Heat uncovered at low power to bring out flavor.
Bacon	1/4 lb (100 g)	900	2 – 3	Place on paper towel, do not cover.
Softening ice cream	1/2 gallon (500 g)	150	2	Place open ice cream container in microwave oven.
Skinning tomatoes	3 tomatoes	450	6 – 7	Cut a cross into the top of each tomato, cover, and heat in a little water. The skins will slip off easily. The tomatoes can get very hot.
Preparing strawberry jam	1 lb (300 g) strawberries, 1 1/2 cups (300 g) sugar	900	7 – 9	Mix the fruit and sugar in a deep container, cover and cook

The information provided in this chart is intended as a guide only.

Saving your favorite programs

One favorite program can be saved into memory. This program can be used for your most frequently cooked recipe. The program can have up to 3 stages (for example: 2 minutes at 600 W, followed by 10 minutes at 450 W, and finally 3 minutes at 300 W).

Programming

(The example given is for a three-stage program.)

- First, select the power level for the first stage.
- Then, select the duration.

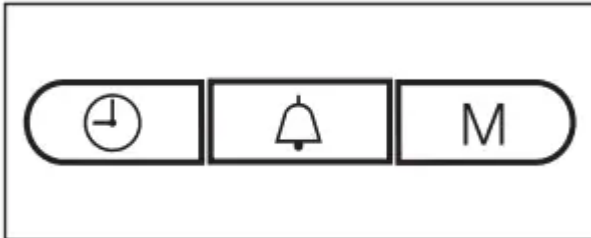

- Press the "M" button. "1" will appear in the display, and "2" will flash.
- Next, select the second power level and duration.
- Press the "M" button again. "2" will appear in the display, and "3" will flash.
- Now, select the third power level and duration and press the "M" button.

After the third step, you can use the "M" button to scroll through your entry and check it.

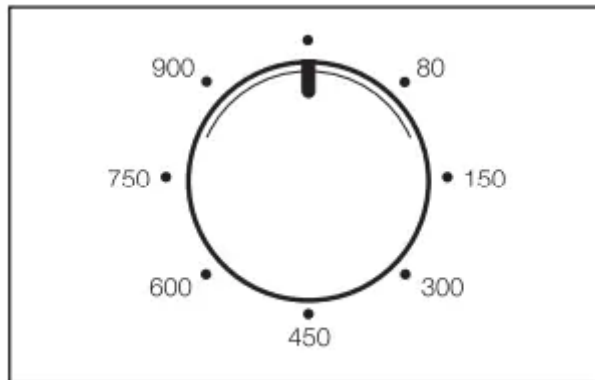

- Once you have finished programming, turn the power selector to the 12 o'clock position.
- Start the program to save the entry. Do not run the entire program unless there is food in the appliance.

If there is no food in the appliance, press the Stop/C button twice as soon as you have started the program to prevent the appliance from being damaged.

One- and two-stage programs can be saved in the same way. The programming process is completed by moving the power selector to the 12 o'clock position and then pressing the Start button. Pressing the M button shows the next stage.

Changing an entry

- You can override the previously saved program by entering a new program.

Using the favorite program

- Turn the power selector to the 12 o'clock position.

- Press the "M" button.
- Press the "Start" button.

If there is a loss of power, the program will no longer be saved and must be reentered.



Changing settings

Some of the appliance's factory default settings can be changed if desired.

See the chart on the following page for the different options available. The original factory settings are marked in the chart with a star*.

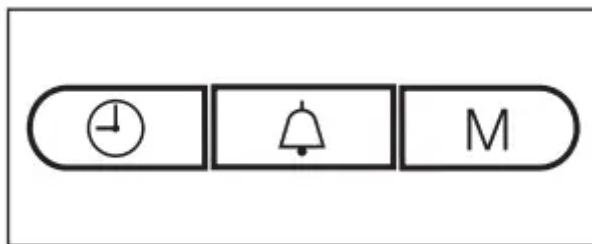
To change a setting, proceed as follows:



- Press and hold the  and "M" buttons at the same time until *P 1* and  appear in the display. Then release them. If you press them for too long, the time of day will appear again in the display.
- Use the selector knob to choose the setting that you wish to change (*P 1* to *P 5* and *P 0*). Turn it until the desired setting shows in the display.
- Then, press the "M" button to call up the setting. S will appear in the display to show that the setting can be changed.
- Turn the selector knob if you wish to change the setting (see table) and confirm your entry by pressing the M button (for *P 5* and *P 0*, press and hold the "M" button for approx. 4 seconds).

The change is then saved to the memory. *P* will appear in the display again, together with the number for the setting.

The other settings can be changed in the same way.

- When you have finished making the desired changes, press the "Stop/C" button.

Changes to the settings remain saved during a power outage.

Settings		Available settings (* factory default)	
P 1	Time of day	12 h * 24 h	12-hour clock display. 24-hour clock display.
P 2	Automatic "Keep warm" function	S 1 * S 0	The keep-warm function is activated. The keep-warm function is deactivated.
P 3	"Door" message	S 1 * S 0	The "Door" message appears if the door has not been opened in the last 20 minutes before Start is pressed. Start is then blocked. The "Door" message does not appear.
P 4	Reminder signal	S 1 * S 0	The reminder signal sounds briefly every 5 minutes for 20 minutes after the end of the program. The reminder signal is deactivated.
P 5	Demo mode (for presentations in dealer showrooms or at trade shows)	S 0 * S 1	Demo mode is not activated. When the active demo mode is deactivated, " _ _ _ _ " will briefly appear in the display. The appliance is set to demo mode. When a button or selector is operated, <i>NE5_</i> shows briefly in the display. The appliance can be operated, but the microwave function does not work.
P 6	Unit of weight	S 1 * S 0	Food weight is displayed in pounds (lb). Food weight is displayed in grams (g).
P 0	Factory default settings	S 1 * S 0	Factory default settings have been restored, or have not been changed. Factory default settings have been changed.

Cleaning and care

Do not use a steam-cleaner to clean the microwave oven.

Steam can reach the live electrical components of the appliance and cause a short circuit.

Oven interior and inside of door

WARNING: The oven interior can get hot during use. Burn hazard! Clean the appliance interior as soon as the microwave has cooled down. Waiting too long can make cleaning unnecessarily difficult and, in extreme cases, impossible. Under certain conditions, heavy grease and grime can damage the appliance and even be dangerous. Fire hazard!

The oven interior and inside of the door can be cleaned using a damp cloth with a mild cleaner or liquid dish soap mixed with water. Wipe dry with a soft cloth.

For grease and grime, heat a glass of water for 2 to 3 minutes until the water begins to boil. The steam will collect on the walls and soften the buildup. The oven interior can now be wiped clean (with a liquid dish soap if necessary).

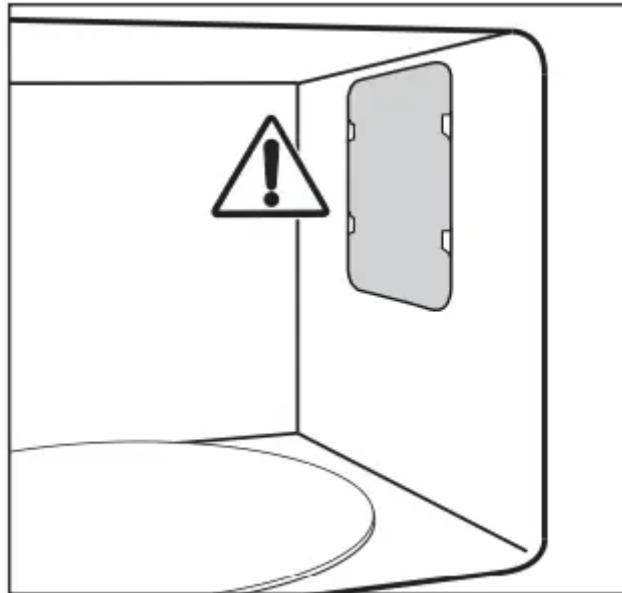

Do not remove the plate cover to the microwave outlet in the oven interior or the film that covers the inside of the door.

Do not let water or any objects penetrate the vents in the appliance.

Wring out cloths before using them to wipe out the oven interior to prevent moisture from getting into the openings.

Do not use abrasive cleaners, since these will scratch the appliance surfaces.

To neutralize odors in the microwave oven, put a cup of water with some lemon juice in the oven interior and heat for a few minutes, or until boiling.

The door should be kept clean at all times and checked at regular intervals for any signs of damage.

WARNING: If you notice any damage to the door, do not use the appliance until the defect has been repaired by a Miele authorized technician.

To clean the oven interior:

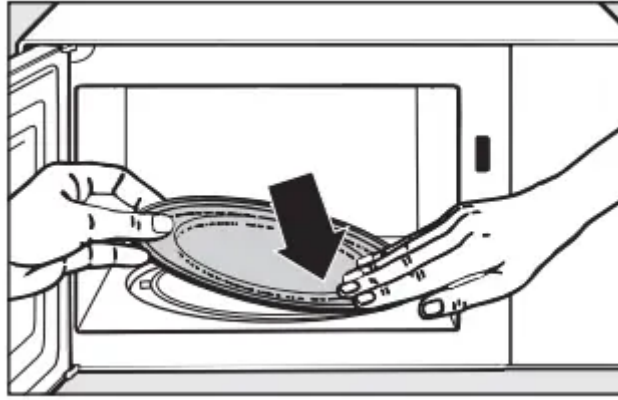

- Remove the turntable and wash it either in the dishwasher or by hand with a liquid dish soap and water.

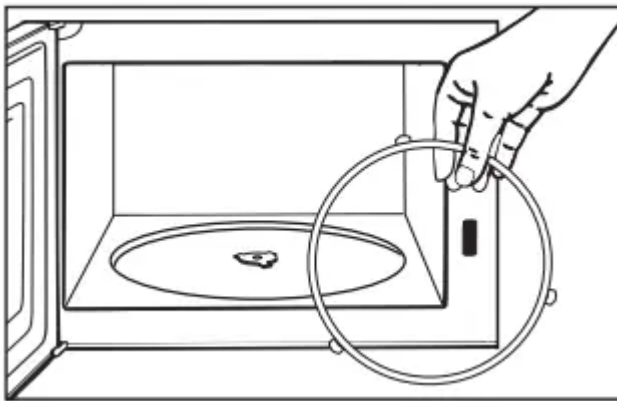

- Always keep the roller ring and the oven floor below the turntable clean so that the turntable can turn smoothly.
- Clean the contact surfaces between the turntable and the roller ring.

Do not turn the support manually, as this could damage the drive motor.

Appliance front

Do not let water or any object get into or block the air vents in the door frame.

It is best to remove any grease and grime on the appliance front immediately.

If it remains on the surface for a longer period of time, it may become impossible to remove, causing the surfaces to discolor or change.

Clean the front with a clean sponge and a solution of hot water and dish soap. After cleaning, dry the front with a soft cloth.

A clean, damp microfiber cloth can also be used without cleaner.

All of the appliance surfaces are easily scratched. Scratches on glass surfaces may even lead to breakage under certain conditions. Contact with unsuitable cleaners can alter or discolor the surfaces.

To avoid damaging the surfaces when cleaning, do not use any of the following:

- Cleaning products containing soda, ammonia, acid or chloride
- Lime removers
- Abrasive cleaning products, such as scouring powder, scouring liquid, or pumice stones
- Cleaners containing solvents
- Stainless steel cleaners
- Dishwasher cleaner
- Oven sprays
- Glass cleaners
- Hard, abrasive sponges and brushes, such as pot scrubbers
- Eraser sponges
- Sharp metal scrapers

Included accessories

Boiling stick

The boiling stick is dishwasher safe.

Plate cover

Wash and dry the plate cover after each use.

The plate cover can be washed in a dishwasher. However, discoloration caused by natural dyes, e.g. from carrots, tomatoes or ketchup, may occur.

This discoloration is permanent but will not affect the stability of the cover.

Warning

This content is compiled from multiple sources and is provided for reference purposes only. It may not be complete or fully applicable to all situations. If you are unable to resolve your issue, please contact the product manufacturer or an authorized service provider for official support.

