

ASSEMBLY

Assembly Instructions

1. Install the wand into the body until it clicks into place (A). If your model comes with the Dust Chaser Hand Vacuum, first connect the adapter into the body until it clicks into place (B).

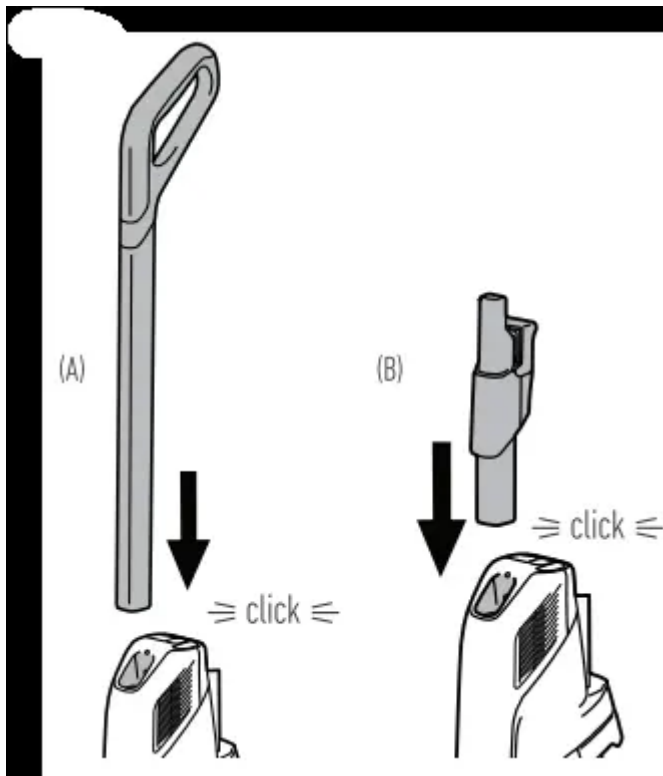

2. Push the hand vacuum onto the adapter until it clicks into place.

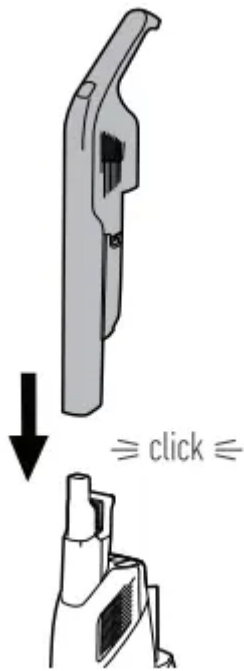

3. Attach the battery pack by aligning the ribs on the battery in the product. Slide the battery pack into the product until it clicks into place.

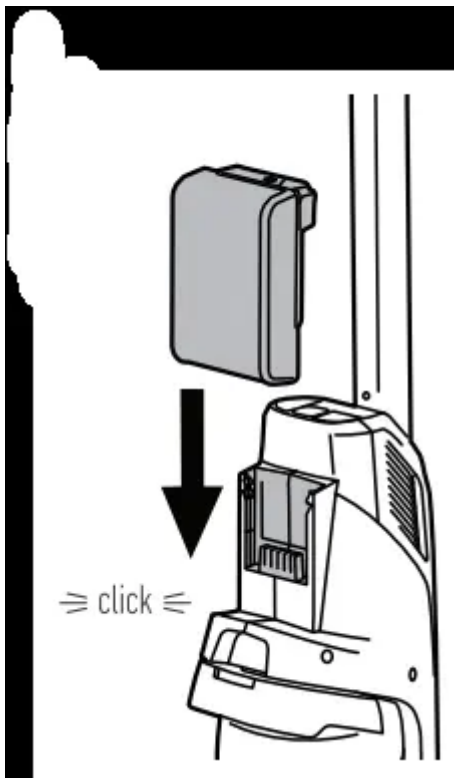

Charging The Battery

1. Plug the charger into a power outlet.

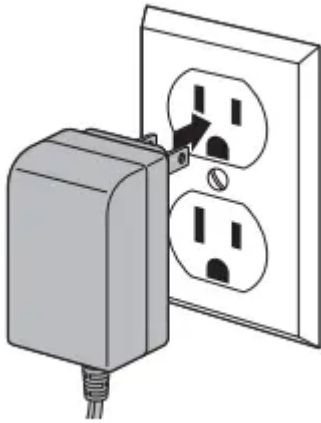

2. Attach the battery pack to the charger by aligning the ribs on the battery pack to the grooves in the charger. Slide the battery pack into the charger.

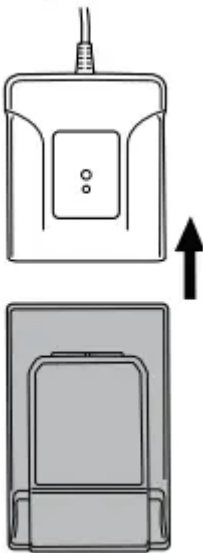

3. When charging, the lights on the battery will illuminate to show the state of charge. If the light on the charger flashes red, there is an error with the battery or the charger. Try again or call customer service for support. Once charge is complete, lights on the battery will turn off.

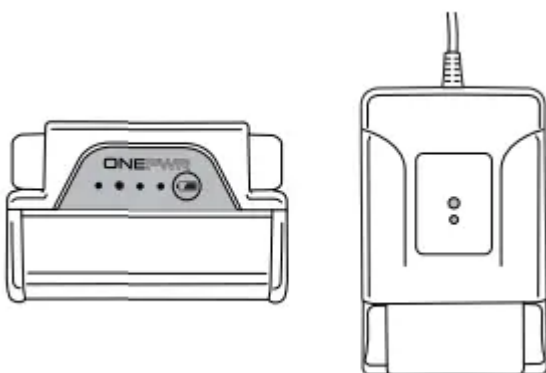

4. To remove the battery pack from the charger, press the latches and pull the battery away from the charger.

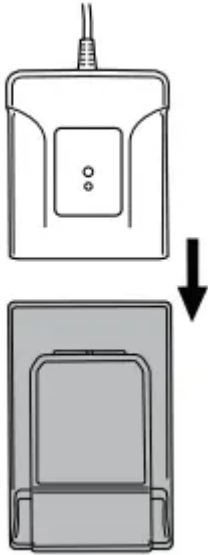

Tips: During charging, the pack and ambient temperature should be between 41°F to 86°F (5°C and 30°C). The charger will sense if the pack, or ambient temperature, is too cold or too hot, and will return an error code (red LED will be on) and not charge the pack. Use battery only with charger listed. For use with Hoover® ONEPWR™ Lithium Ion Batteries.

PRODUCT OVERVIEW

Dust Chaser™ Hand Vacuum not included with alt models.

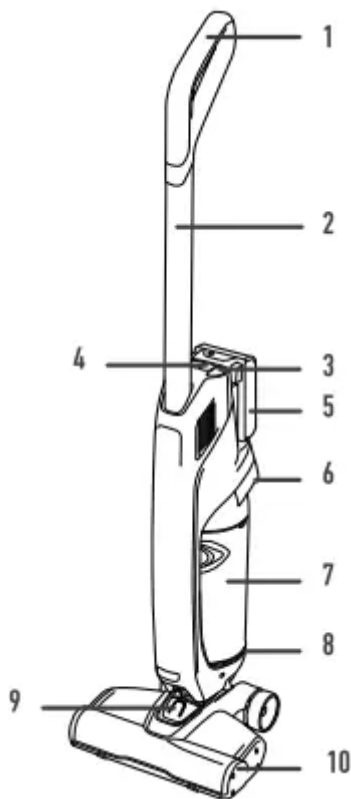

1. Comfort Grip Handle

2. Wand
3. ON/OFF Button
4. Mode Buttons & LED Mode Display
5. ONEPWR™ Battery
6. Filter/Separator Access
7. Easy Empty Dirt Cup
8. Dirt Cup Empty Button
9. Hose Release
10. Removable Brush Roll

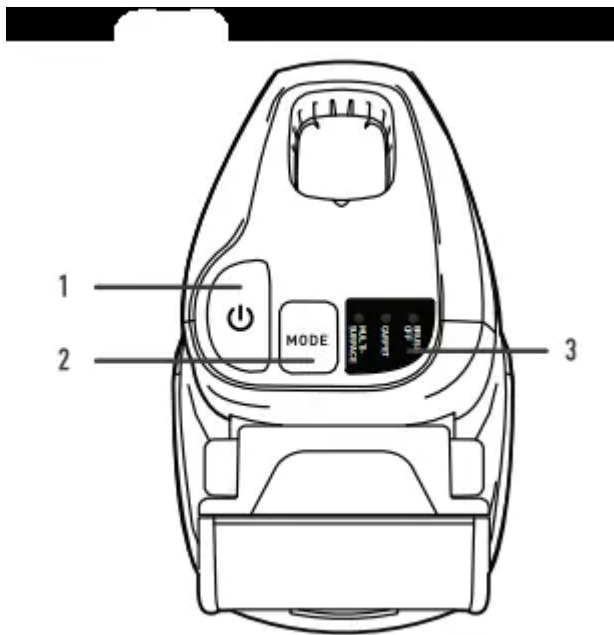

1. ON/OFF Button
2. Mode button
3. LED Mode Display

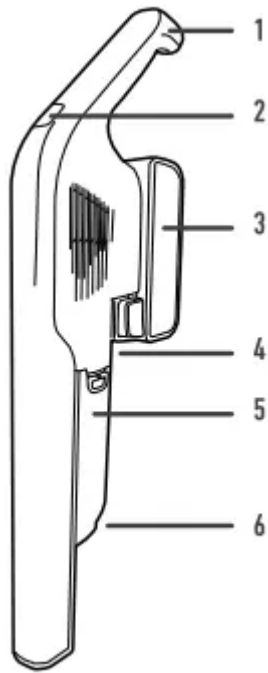

1. Comfort Grip Handle
2. ON/OFF Button
3. ONEPWR™ Battery
4. Filter Access
5. Separator Access
6. Dirt Cup Release Button

OPERATION

CAUTION:

- Use extra care when cleaning on stairs. To avoid personal injury or damage, and to prevent the cleaner from falling, always place cleaner at bottom of stairs or on floor. Do not place cleaner on stairs or furniture, as it may result in injury or damage.
- Not to be used for grooming a pet.

1. Press the ON/OFF button located on the shoulder. The ON/OFF button and mode Indicator lights will illuminate when ON.

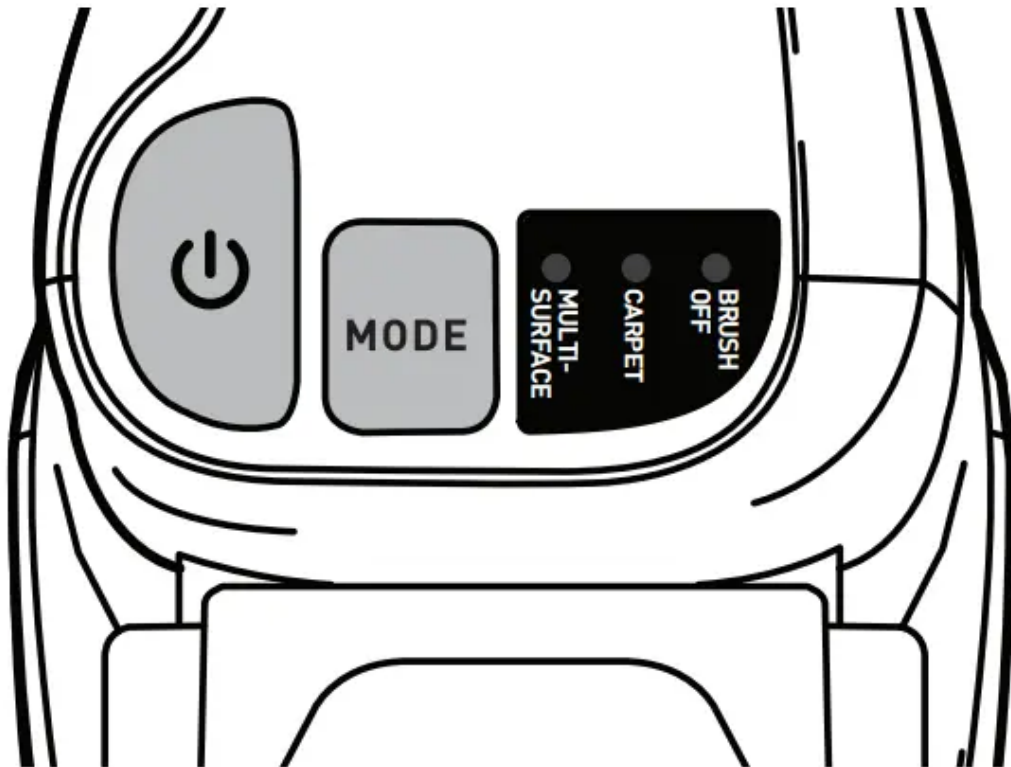

2. To change modes, press the Mode button on the shoulder. The mode indicators will illuminate, telling you which mode you are in.

- Evolve defaults to Multi-Surface Mode. This mode works well on all floor types and preserves runtime.
- Use Carpet Mode for deep cleaning on carpets with high suction.
- Use Brush Mode Off on delicate floor types. This mode has high suction with the brush roll off.

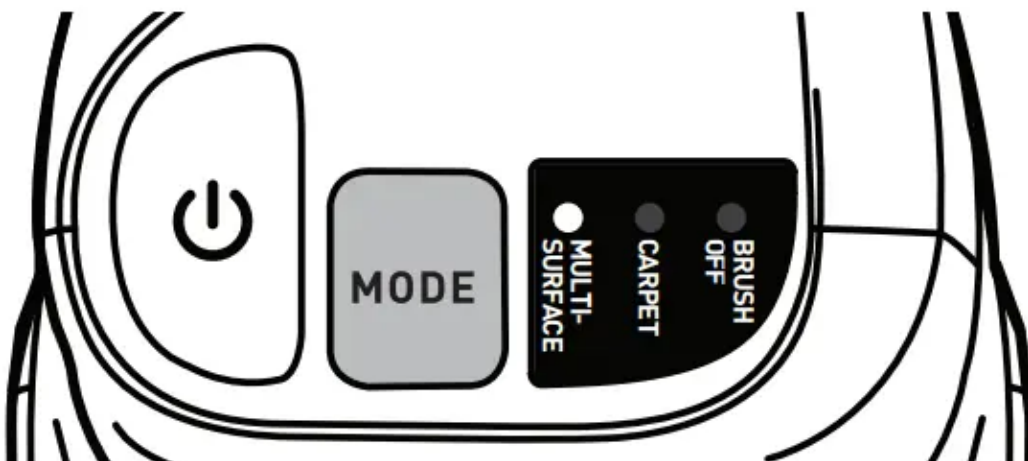

3. Step on the nozzle of the product and pull back handle to recline and begin cleaning.

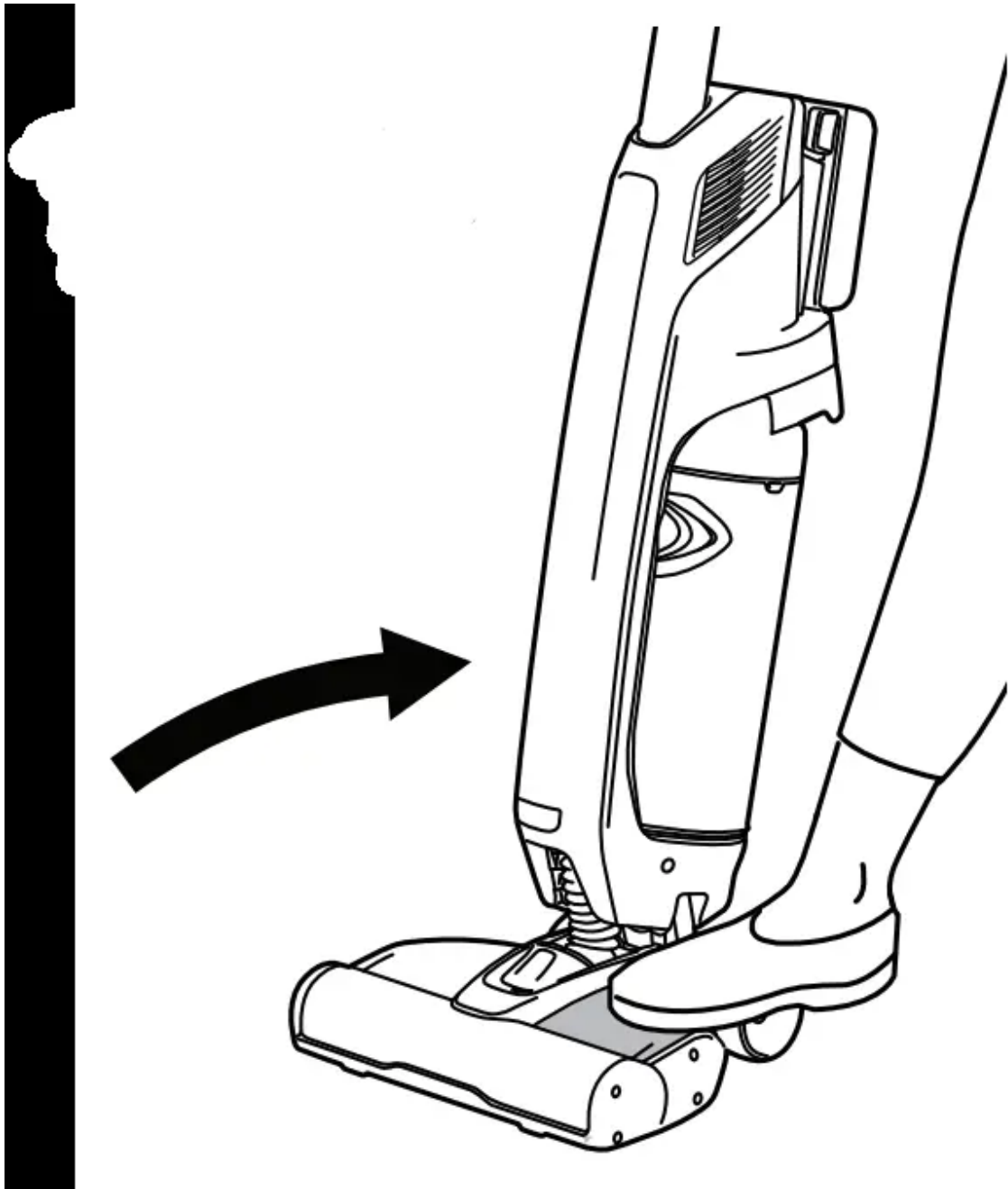

Using the ONEPWR™ Dust Chaser™ Hand Vacuum

Dust Chaser™ Hand Vacuum not included with all models.

1. To use the hand vacuum for above floor cleaning, depress the hand vacuum upwards off the adapter.

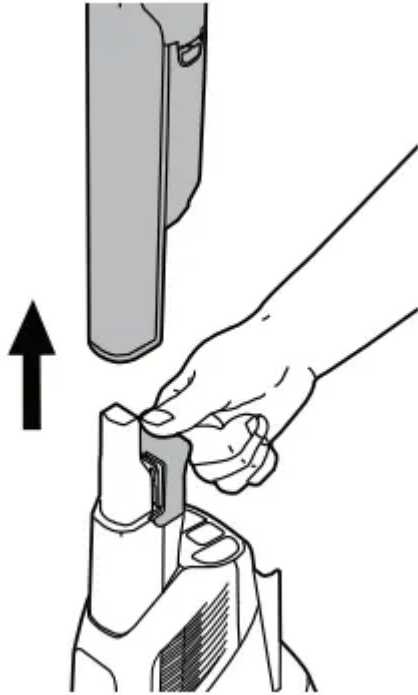

2. Remove the battery from the Evolve upright and insert into the hand vacuum.

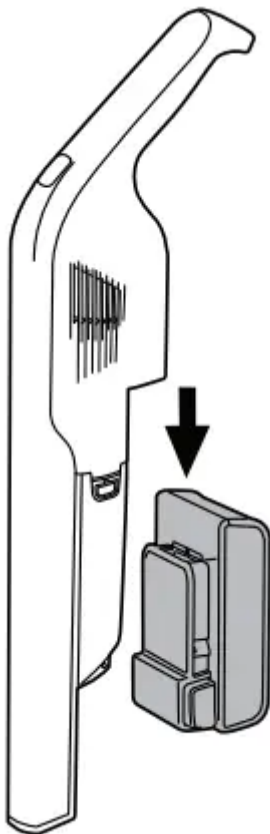

3. Press ON/OFF button located on the top of the hand vacuum.

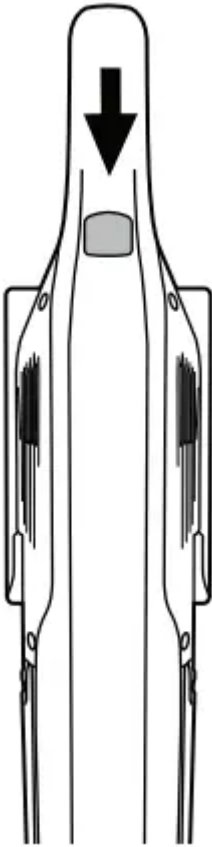

4. For detailed cleaning, choose an accessory and push the accessory onto the end of the hand vacuum.

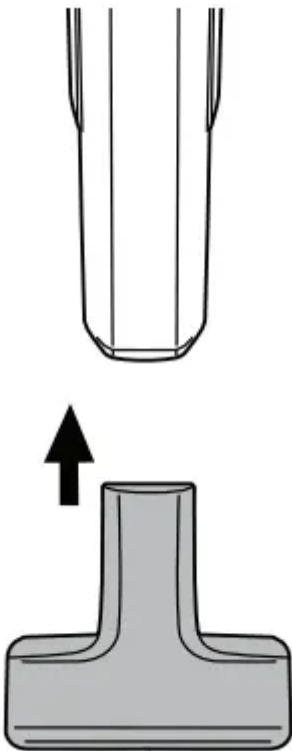

5. To remove the accessory, pull out.

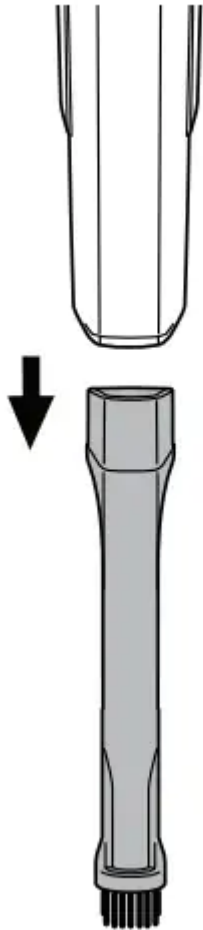

MAINTENANCE

Emptying the dirt cup

Warning: To reduce the risk of injury from moving parts, remove the battery before servicing

1. Remove the battery pack

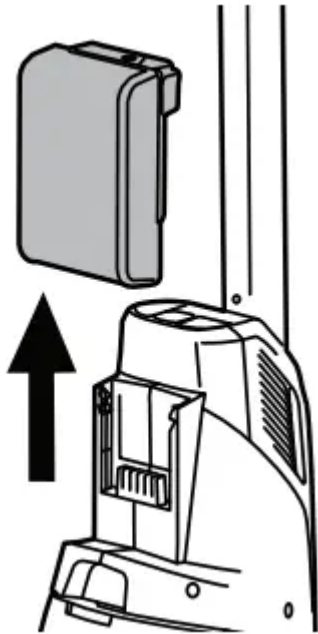

2. Push down the latch on the dirt cup to release. Rock the dirt cup backwards off the body.

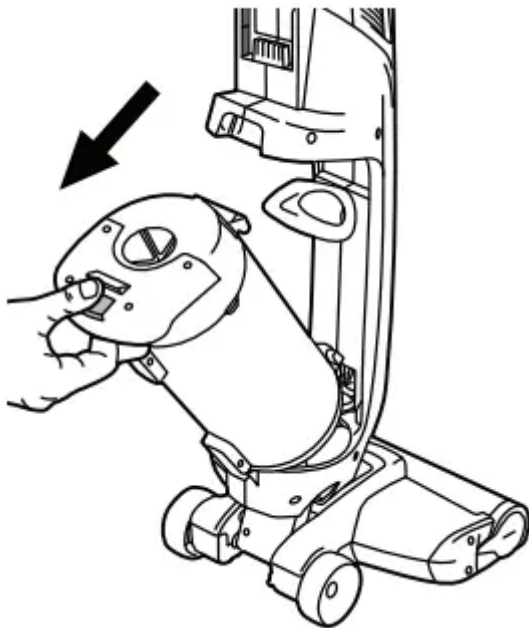

3. Hold the dirt cup over a trash bin and press the dirt cup release button to empty.

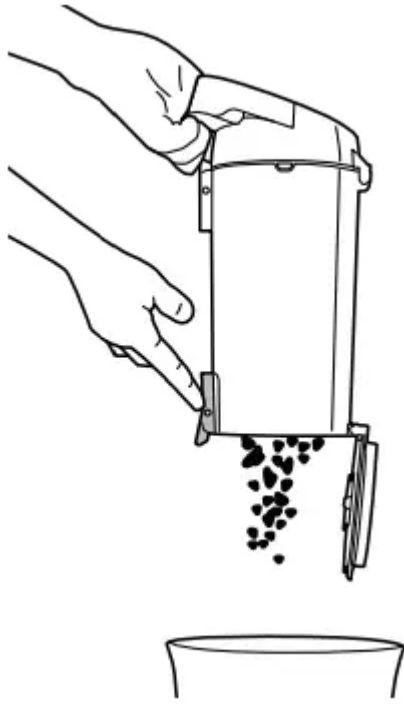

4. To close, push the door until it locks back into place.

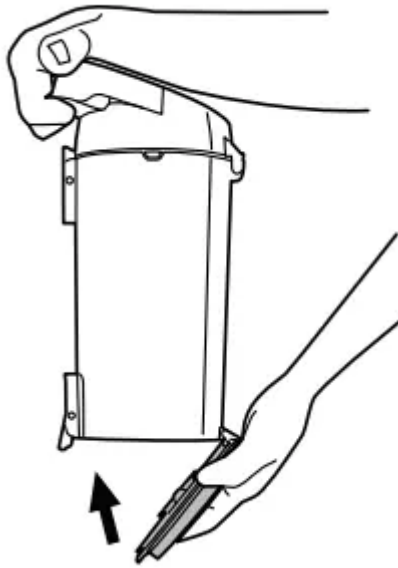

5. Replace the dirt cup by aligning the bottom first and then rocking it into place.

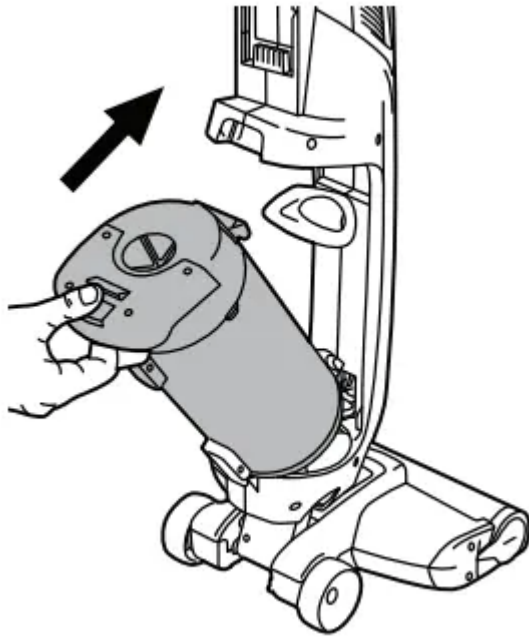

Cleaning the filter and separator

1. Open the dirt cup lid to access the filter and separator.

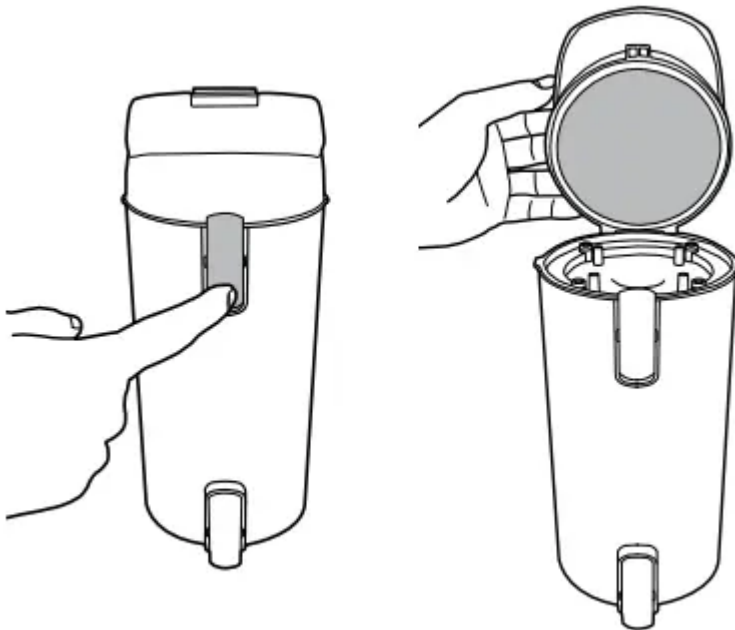

2. To clean the separator, lift to remove. Clean dirt and debris by wiping the metal screen with a cloth and then place back into the dirt cup.

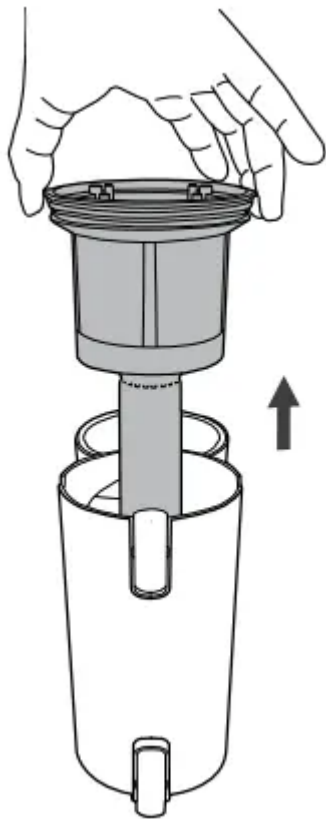

3. Pull the filter away and tap over a trash can to remove dirt. Rinse filter under warm water until water comes out clear. Allow filter to air dry for at least 24 hours until fully dry.

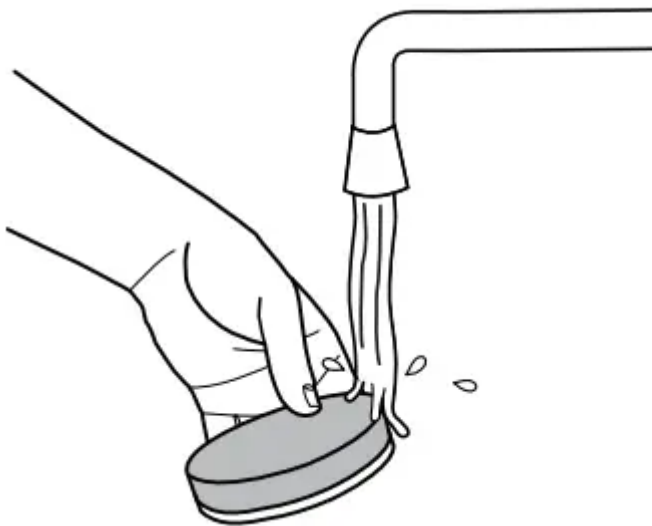

Removing and replacing the brush roll

Warning: Risk of personal injury - Brush roll may suddenly restart. Turn power switch off and remove battery before cleaning or servicing

1. Remove the battery. Using your fingers or a coin, push and turn the brush rail lock counterclockwise to release the brush roll.

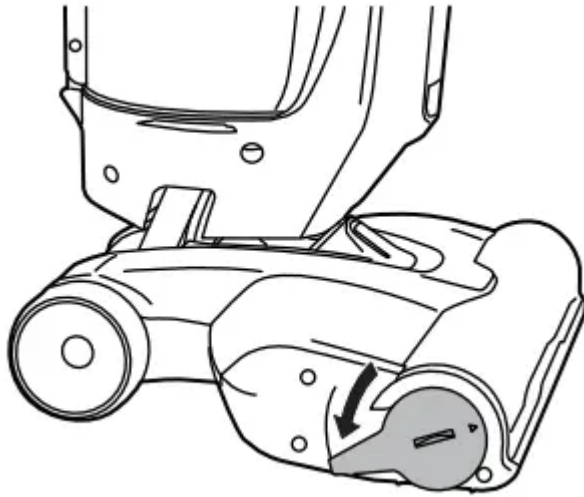

2. Pull the brush roll out of the nozzle with the pull tab.

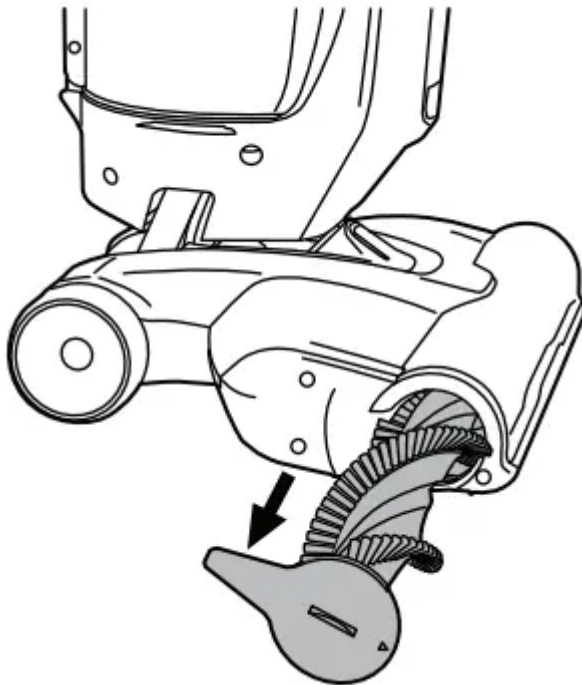

3. To remove any threads or hair, slide the blade of a pair of scissors into the groove of the brush roll and cut along the groove. Clear any dirt/debris from the nozzle.

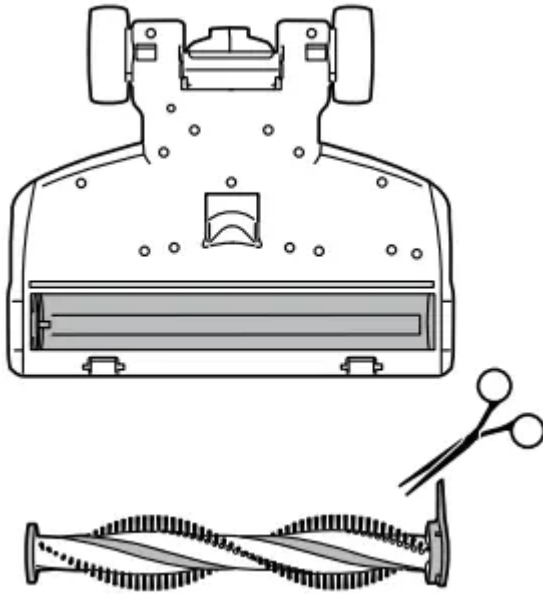

4. Re-fit the brush roll into the nozzle and turn the brush roll lock clockwise to lock.

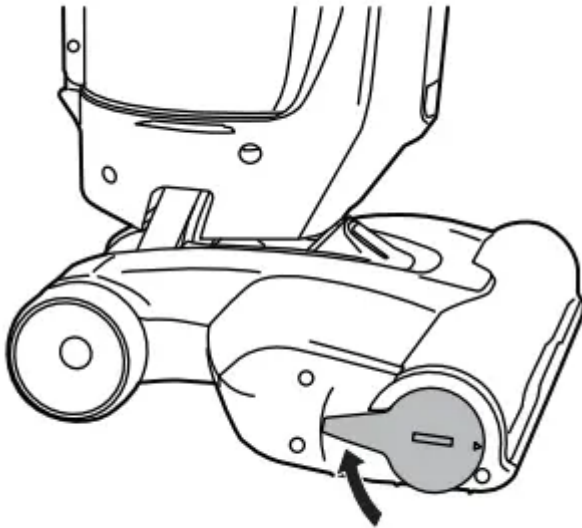

Emptying the Dust Chaser™ Hand Vacuum dirt cup.

Dust Chaser™ Hand Vacuum not included with all models.

1. Remove the battery pack.

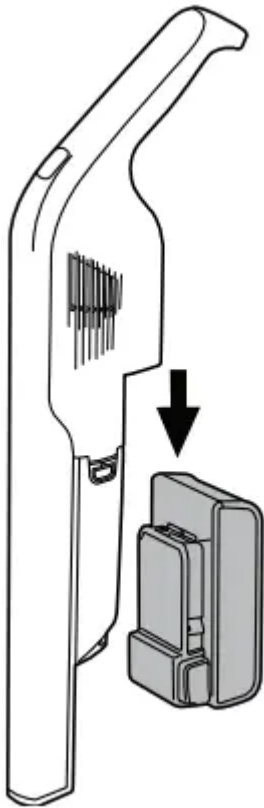

2. Remove the Dust Chaser™ Hand Vacuum.

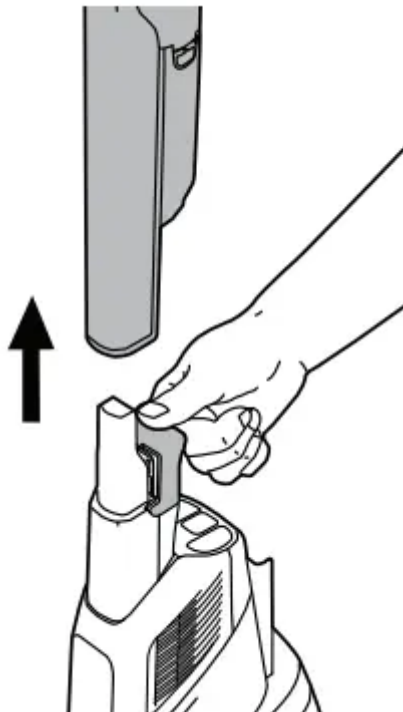

3. Push down on the Dirt Cup Release button and pivot outward to remove the dirt cup.

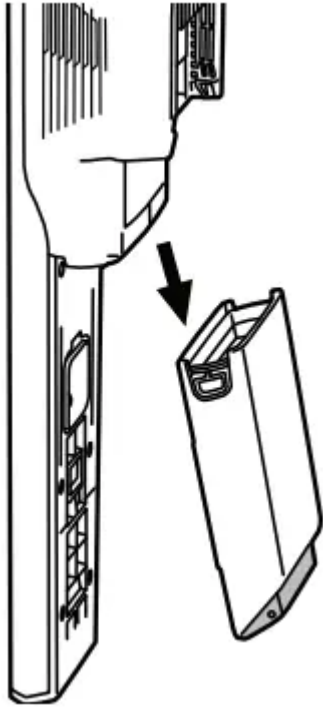

4. Pull out the separator. Clean dirt and debris by wiping the metal screen with a cloth.

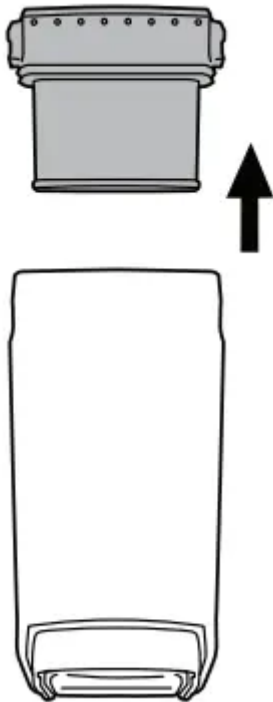

5. Empty the debris into a trash bin.

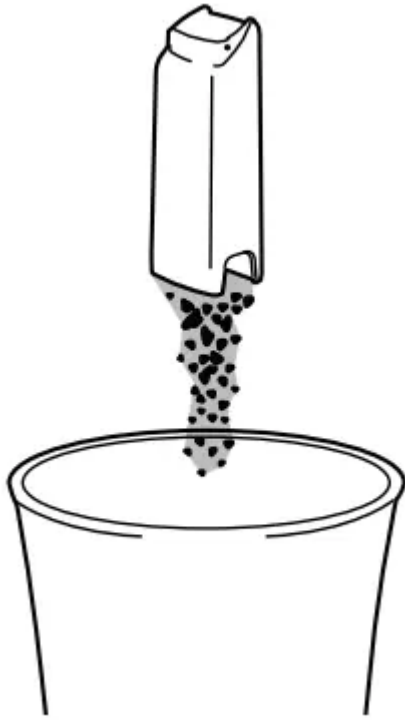

6. Reinstall the separator and place the dirt cup back into place until it clicks.

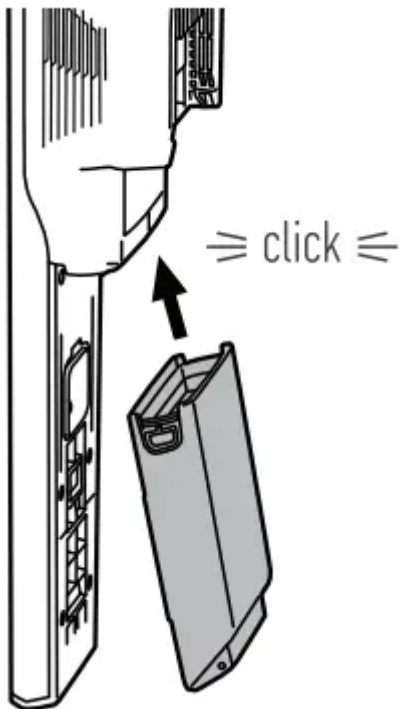

Cleaning the Dust Chaser™ Hand Vacuum filter.

Dust Chaser™ Hand Vacuum not included with all models.

1. Remove the battery pack.

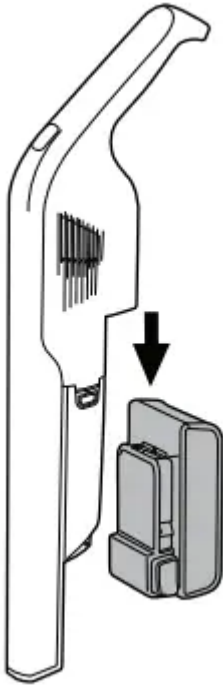

2. Flip the unit over so you can see the bottom on the hand vacuum.

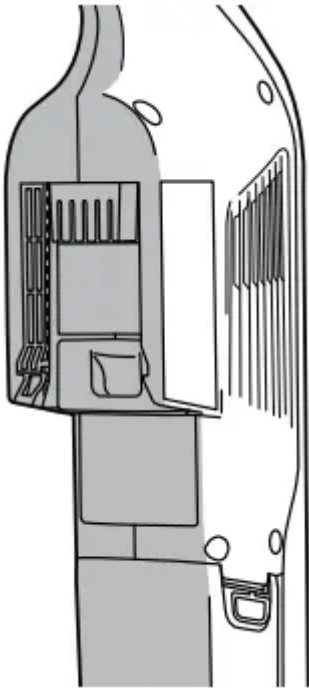

3. Pinch the filter access door lever and pull out.

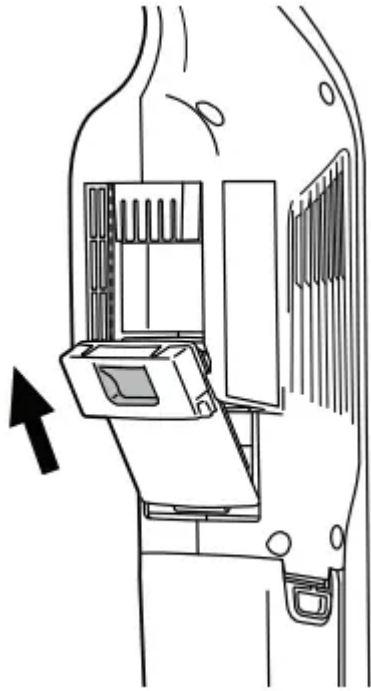

4. Pull the filter away (A). Fold the foam piece back (B) and then tap over a trash can to remove dirt.

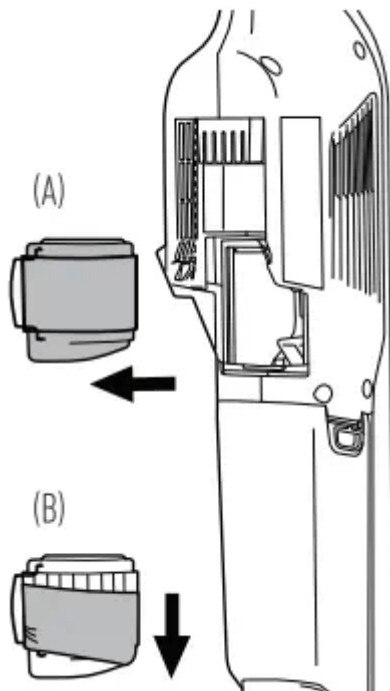

5. Rinse filter and foam piece under warm water until water is clear. Allow to air dry for at least 24 hours until fully dry.

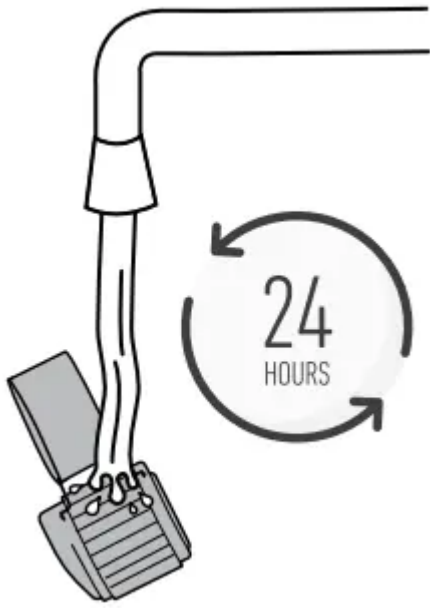

ACCESSORIES



Every ONEPWR" battery works with every ONEPWR™ product.

Battery:	Model #
2.0 Ah	BH15020
3.0 Ah	BH15030
3.0 Ah MAX	BH25030
4.0 Ah	BH15240
4.0 Ah MAX	BH25040
6.0 Ah	BH15260
Parts and Accessories:	
Charger	BH05000
ONEPWR™ Dust Chaser™ Hand Vacuum	BH57010NP
Hand Vacuum 2-in-1 Crevice/ Dusting Tool	AH43800PC
Hand Vacuum Upholstery Tool	AH43810PC
Evolve Upright Filter	AH43000
Dust Chaser™ Hand Vacuum Filter	AH44100
Dust Chaser™ Hand Vacuum Filter Access Door	440014473



Dust Chaser™ Hand Vacuum Adapter	AH43020PC
-------------------------------------	-----------

Warning

This content is compiled from multiple sources and is provided for reference purposes only. It may not be complete or fully applicable to all situations. If you are unable to resolve your issue, please contact the product manufacturer or an authorized service provider for official support.

Document generated by [ManualsFile](#)

