

PARTS AND FEATURES

This manual may cover several different models. The model you have purchased may have some or all of the features shown here. The appearance of your particular model may differ slightly from the illustrations in this manual.

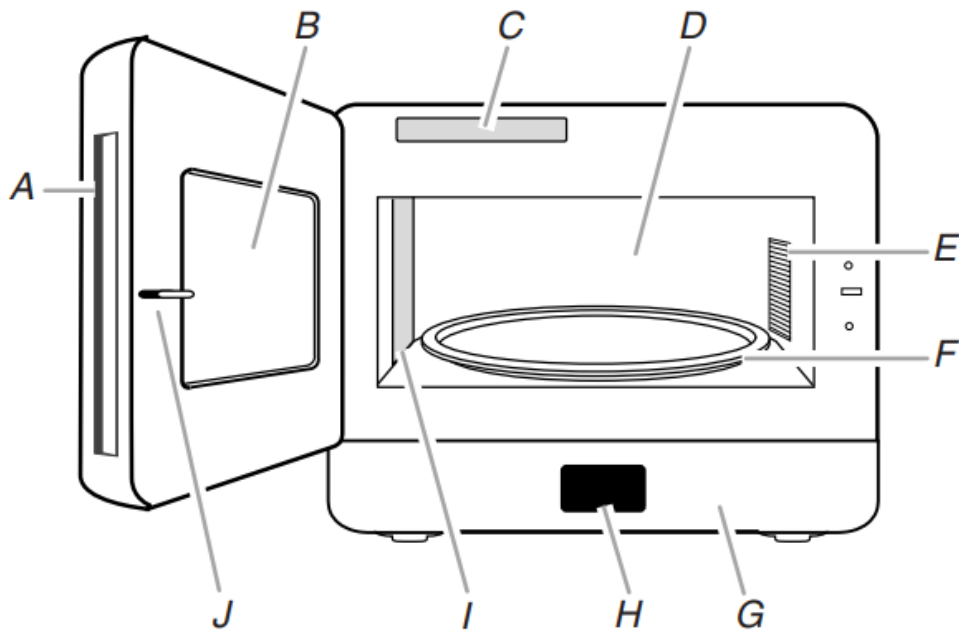

A. Pocket door handle

B. Window

C. Model and serial number plate

D. Rounded cavity (rear wall)

E. Microwave oven light

F. Glass turntable and support

G. Control panel

H. Display

I. Microwave inlet cover

J. Door lock system

Turntable

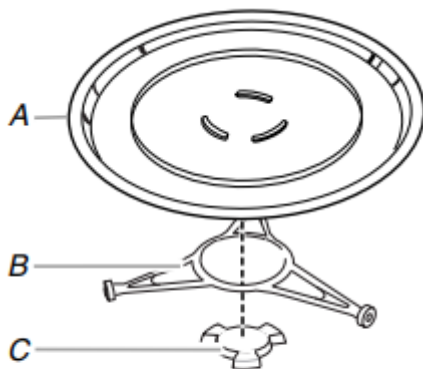

A. Turntable

B. Support

C. Hub

The turntable can rotate in either direction to help cook food more evenly. For best cooking results, do not operate the microwave oven without having the turntable in place. See “Assistance or Service” to reorder any of the parts.

To Install:

1. Place the support on the microwave oven cavity bottom.
2. Place the turntable on the support. Fit the raised, curved lines in the center of the turntable bottom between the three spokes of the hub. The rollers on the support should fit inside the turntable bottom ridge.

MICROWAVE OVEN CONTROL

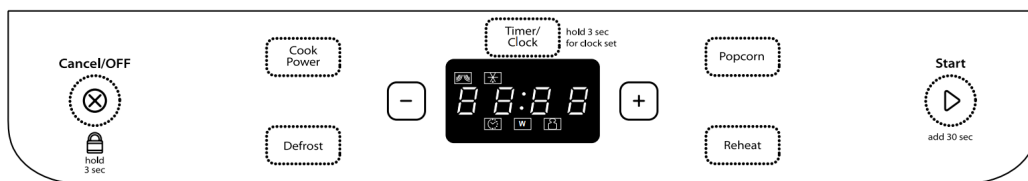

Display

When power is first supplied to the microwave oven, “:” will appear in the display. If the “:” appears in the display at any other time, a power failure has occurred. Reset the clock if needed. While the microwave oven is being programmed, the display shows cooking power, quantities, weights and/or prompts. When the microwave oven is not in use, the display shows the time of day (if the Clock is set) or Timer countdown.

Function Icons

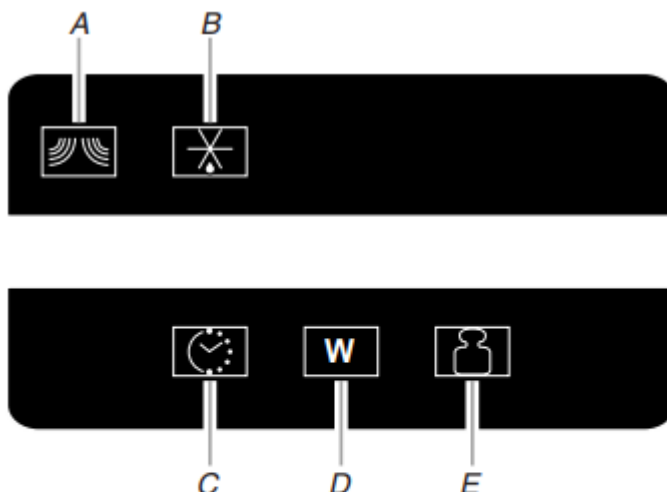

- A. Microwaves
- B. Defrost
- C. Cook time
- D. Cook power
- E. Weight

The icons will light up and/or flash in the display while their specific functions are being programmed. The lit icon indicates the function, and the flashing icon is a prompt for input.

During cooking, the cook function and cook time icons are lit, and the cook time counts down in the display. When the microwave oven is not in use, the display shows the time of day (if the clock is set) or Timer countdown.

Start

The START pad begins any function. If cooking is interrupted, touching START will resume the preset cycle.

NOTE: To avoid unintentional operation of the microwave oven, a cooking function cannot be started if the microwave oven door has been closed for about 1 minute or more. The word “door” will appear in the display until the door is opened and closed.

Cancel/Off

The CANCEL/OFF pad clears any incorrect command and cancels any program during cooking. It will not erase the time of day.

The microwave oven will also turn off when the door is opened. Close the door and touch START to resume the cycle.

Add 30 Seconds

The ADD 30 SEC (START - ADD 30 SEC) pad starts the microwave oven for 30 seconds at 100% power. Each additional touch of the pad adds 30 seconds of cook time, up to 30 minutes.

Cook time may be added in 30-second increments to a running manual cooking cycle by repeatedly touching ADD 30 SEC pad during the cycle.

NOTE: To avoid unintentional operation of the microwave oven, a cooking function cannot be started if the microwave oven door has been closed for about 1 minute or more. The word “door” will appear in the display until the door is opened and closed.

Clock

This is a standard 12-hour clock (12:00-11:59).

To Set:

The microwave oven must be off.

1. Touch and hold CLOCK (TIMER/CLOCK) pad for 3 seconds to enter Clock mode. The “hour” digit will flash.
2. Touch [+] or [-] pad repeatedly until the desired hour is displayed (1 to 12).
3. Touch CLOCK pad to confirm the hour. The “minutes” digits will flash.

4. Touch [+] or [-] pad repeatedly until the desired minutes are displayed (0 to 59).
5. Touch CLOCK pad to confirm the minutes and exit Clock mode.

To Cancel Clock: Enter Clock mode, then touch CANCEL/OFF. The “:” will appear in the display.

Timer

NOTE: The Timer does not start or stop the microwave oven. Cook functions may be used while the Timer is counting down. When the cook function is active in the display, touch TIMER/CLOCK to see the Timer count down for 3 seconds.

Touching TIMER/CLOCK while the Timer is active in the display will send the Timer countdown to the background. While the Timer is running in the background, the colon will flash.

The Timer may be set in the following increments, in minutes and seconds:

INCREMENT	TIME SETING
0:05	0:05 to 1:00
0:15	1:15 to 3:00
0:30	3:30 to 6:00
1:00	7:00 to 30:00

To Set:

1. Touch TIMER/CLOCK. The default time of 5 seconds will show in the display.
2. Touch the [+] or [-] pad repeatedly to set the desired time. Touching and holding the pad will cause the display to scroll rapidly through the increments
3. Touch START.

When the set time ends, the end-of-Timer tone will sound.

To Cancel Timer: While the Timer countdown is active in the display, touch CANCEL/OFF.

If a cook function countdown is active in the display, touch TIMER/CLOCK to show the Timer countdown, then touch CANCEL/OFF to cancel the Timer. Touching CANCEL/OFF while a cook function countdown is active in the display will cancel the cook function, not the Timer.

The time can be reset during the countdown by repeating Step 2 above while the Timer is active in the display.

Tones

Tones are audible signals, which cannot be turned off, and indicate the following:

One tone

- Valid entry
- Clock mode entered
- Control lock activated
- End of cooking reminder

Three tones

- End of cooking cycle
- During Defrost cycle, reminder to check, turn, rearrange, or separate food
- Invalid entry

Twenty tones

- End of Timer (very short, quick tones)

Control Lock

The Control Lock disables the control panel pads to avoid unintended use of the microwave oven.

To Lock/Unlock Control: The microwave oven must be off. Touch and hold CANCEL/OFF for 3 seconds until the tone sounds and "Loc" appears in the display. The display will return to time of day mode (if Clock is set) after 3 seconds. Repeat to unlock.

If any control pad is touched while the Control Lock is active, "Loc" reappears in the display for 3 seconds, and invalid entry tones will sound.

A magnetron in the microwave oven produces microwaves which reflect off the metal floor, walls and ceiling and pass through the turntable and appropriate cookware to the food. Microwaves are attracted to and absorbed by fat, sugar and water molecules in the food, causing them to move, producing friction and heat which cooks the food.

- To avoid damage to the microwave oven, do not lean on or allow children to swing on the microwave oven door.
- To avoid damage to the microwave oven, do not operate microwave oven when it is empty.
- Baby bottles and baby food jars should not be heated in microwave oven.
- Clothes, flowers, fruit, herbs, wood, gourds, paper, including brown paper bags and newspaper, should not be dried in microwave oven.
- Paraffin wax will not melt in the microwave oven because it does not absorb microwaves.
- Use oven mitts or pot holders when removing containers from microwave oven.

- Do not overcook potatoes. At the end of the recommended cook time, potatoes should be slightly firm. Let potatoes stand for 5 minutes. They will finish cooking while standing.
- Do not cook or reheat whole eggs inside the shell. Steam buildup in whole eggs may cause them to burst, requiring significant cleanup of microwave oven cavity. Cover poached eggs and allow a standing time.

Food Characteristics

When microwave cooking, the amount, size and shape, starting temperature, composition and density of the food affect cooking results.

Amount of Food

The more food heated at once, the longer the cook time needed. Check for doneness and add small increments of time if necessary.

Size and Shape

Smaller pieces of food will cook more quickly than larger pieces, and uniformly shaped foods cook more evenly than irregularly shaped food.

Starting Temperature

Room temperature foods will heat faster than refrigerated foods, and refrigerated foods will heat faster than frozen foods.

Composition and Density

Foods high in fat and sugar will reach a higher temperature, and will heat faster than other foods. Heavy, dense foods, such as meat and potatoes, require a longer cook time than the same size of a light, porous food, such as cake.

Cooking Guidelines

Covering

Covering food helps retain moisture, shorten cook time and reduce spattering. Use the lid supplied with cookware. If a lid is not available, wax paper, paper towels or plastic wrap approved for microwave ovens may be used. Plastic wrap should be turned back at one corner to provide an opening to vent steam. Condensation on the door and cavity surfaces is normal during heavy cooking.

Stirring and Turning

Stirring and turning redistribute heat evenly to avoid overcooking the outer edges of food. Stir from outside to center. If possible, turn food over from bottom to top.

Arranging

If heating irregularly shaped or different sized foods, arrange the thinner parts and smaller sized items toward the center. If cooking several items of the same size and shape, place them in a ring pattern, leaving the center of the ring empty.

Piercing

Before heating, use a fork or small knife to pierce or prick foods that have a skin or membrane, such as potatoes, egg yolks, chicken livers, hot dogs, and sausage. Prick in several places to allow steam to vent.

Shielding

Use small, flat pieces of aluminum foil to shield the thin pieces of irregularly shaped foods, bones and foods such as chicken wings, leg tips and fish tail. See “Aluminum Foil and Metal” first.

Standing Time

Food will continue to cook by the natural conduction of heat even after the microwave cooking cycle ends. The length of standing time depends on the volume and density of the food.

Cookware and Dinnerware

Cookware and dinnerware must fit on the turntable. Always use oven mitts or pot holders when handling because any dish may become hot from heat transferred from the food. Do not use cookware and dinnerware with gold or silver trim. Use the following chart as a guide, then test before using.

MATERIAL	RECOMMENDATIONS
Aluminum Foil, Metal	See “Aluminum Foil and Metal” section.
Browning Dish	Bottom must be at least 3/16" (5 mm) above the turntable. Follow manufacturer’s recommendations.
Ceramic Glass, Glass	Acceptable for use.
China, Earthenware	Follow manufacturer’s recommendations.
Melamine	Follow manufacturer’s recommendations.
Paper: Towels, Dinnerware, Napkins	Use nonrecycled and those approved by the manufacturer for microwave oven use.
Plastic: Wraps, Bags, Covers, Dinnerware, Containers	Use those approved by the manufacturer for microwave oven use.
Pottery and Clay	Follow manufacturer’s recommendations.
Silicone Bakeware	Follow manufacturer’s recommendations.
Straw, Wicker, Wooden Containers	Do not use in microwave oven.



MATERIAL	RECOMMENDATIONS
Wax Paper	Acceptable for use.

To Test Cookware or Dinnerware for Microwave Use:

1. Place cookware or dinnerware in microwave oven with 1 cup (250 mL) of water beside it.
2. Cook at 100% cooking power for 1 minute.

Do not use cookware or dinnerware if it becomes hot and the water stays cool.

Aluminum Foil and Metal

Always use oven mitts or pot holders when removing dishes from the microwave oven.

Aluminum foil and some metal can be used in the microwave oven. If not used properly, arcing (a blue flash of light) can occur and cause damage to the microwave oven.

OK for Use

Racks and bakeware supplied with the microwave oven (on some models), aluminum foil for shielding, and approved meat thermometers may be used with the following guidelines:

- To avoid damage to the microwave oven, do not allow aluminum foil or metal to touch the inside cavity walls, ceiling or floor.
- Always use the turntable.
- To avoid damage to the microwave oven, do not allow contact with another metal object during microwave cooking.

Do Not Use

Metal cookware and bakeware, gold, silver, pewter, nonapproved meat thermometers, skewers, twist ties, foil liners such as sandwich wrappers, staples and objects with gold or silver trim or a metallic glaze should not be used in the microwave oven.

Microwave Cooking Power

Many recipes for microwave cooking specify which cooking power to use by percent or name.

When COOK POWER is touched, the display shows the default power of 100%. Each additional touch of the pad scrolls through the available power levels: 0%, 25%, 50%, 75%, then back to 100%.

Use the following chart as a general guide for the suggested cooking power of specific foods.

PERCENT/ NAME	USE
100%, High (default setting) (700W)	Quick heating convenience foods and foods with high water content, such as soups, beverages and most vegetables.
	Cooking small, tender pieces of meat, ground meat, poultry pieces and fish fillets. Heating cream soups.
75%, Medium-High (500W)	Heating rice, pasta or stirrable casseroles. Cooking and heating foods that need a cook power lower than high. For example, whole fish and meat loaf.
	Reheating a single serving of food.
50%, Medium (350W)	Cooking sensitive foods such as cheese and egg dishes, pudding and custards. Cooking non-stirrable casseroles, such as lasagna.
	Cooking ham, whole poultry and pot roasts. Simmering stews. Melting chocolate. Heating bread, rolls and pastries.
25%, Low, Defrost (160W)	Defrosting bread, fish, meats, poultry and precooked foods. Softening butter, cheese, and ice cream.
	Taking chill out of fruit.
0% No power	



Manual Cooking

Cook time may be set in the following increments, in minutes and seconds:

INCREMENT	TIME SETTING
0:05	0:05 to 1:00
0:15	1:15 to 3:00
0:30	3:30 to 6:00
1:00	7:00 to 30:00

To Use:

1. Place food on the turntable and close the door.
2. Touch the [+] or [-] pad. The default time of 5 seconds will show in the display. Touch the [+] or [-] pad repeatedly to set the desired time. Touching and holding the pad will cause the display to scroll rapidly through the increments.

If cooking with 100% power, skip Step 3.

3. Touch COOK POWER. The default power level of 100% will show in the display. Touch COOK POWER repeatedly to scroll to the desired power level. See “Microwave Cooking Power.”

4. Touch START.

The display will count down the cook time.

When the cycle ends. “End” will appear in the display, and the end-of-cycle tones will sound.

5. Touch CANCEL/OFF or open the door to clear the display and/or stop reminder tones.

NOTE: Manual cooking may be started by setting the power level first. Within 3 seconds of setting the power level, the display automatically switches to cook time mode, showing the default time of 5 seconds.

To Change Cook Time During Cooking: Touch [+] or [-] pad

repeatedly to set new time, or add time in 30-second increments by touching START - ADD 30 SEC pad. New time is set immediately.

To Change Cook Power During Cooking: Touch COOK POWER repeatedly to scroll through the power levels. New power is set immediately.

Defrost

The automatic Defrost feature can be used or the microwave oven can be manually set to defrost.

- Unwrap foods and remove lids (for example, from fruit juice containers) before defrosting.

- Shallow packages will defrost more quickly than deep blocks.
- Separate food pieces as soon as possible during or at the end of the cycle for more even defrosting.
- Use small pieces of aluminum foil to shield parts of food such as chicken wings, leg tips and fish tails. See “Aluminum Foil and Metal” first.

The Defrost feature uses weight input. It should not be used for food that has been left outside the freezer for more than 20 minutes, or for frozen ready-made food.

To Use Defrost:

1. Place food, uncovered, on the turntable and close the door.
2. Touch DEFROST. The default weight of 1.5 lbs will show in the display.
3. Touch the [+] or [-] pad repeatedly to set the desired food weight. Touching and holding the pad will cause the display to scroll rapidly through the available weights, in 0.1-lb increments.

Weight can be set from 0.2 lb to 3.3 lbs (90 g to 1.5 kg).

4. Touch START.

The display will count down the defrost time.

During defrosting, 3 tones will sound, and the display will show the “turn Food” prompt. Open door, turn food if necessary, close door, and touch START to resume defrosting. If no action is taken, the Defrost cycle will automatically resume in 2 minutes. Touching START during the 2 minute pause will also resume the cycle, without having to open the door.

When the cycle ends, “End” will appear in the display, and the end-of-cycle tones will sound.

5. Touch CANCEL/OFF or open the door to clear the display and/or stop reminder tones.

NOTE: Defrost times and cook power cannot be changed during an automatic Defrost cycle.

To Defrost Manually: Follow directions in “Manual Cooking” section, and use 25% cooking power. See “Microwave Cooking Power” chart.

Reheat

The microwave oven’s Reheat feature can be used or the microwave oven can be manually set to reheat. Reheat time may be set in the following increments, in minutes and seconds:

INCREMENT	TIME SETING
0:05	0:05 to 1:00
0:15	1:15 to 3:00
0:30	3:30 to 6:00
1:00	7:00 to 30:00



To Use Reheat:

1. Place food on the turntable, and close the door.
2. Touch REHEAT. The default power of 75% will show briefly in the display, followed by the default time of 5 seconds.
3. Touch the [+] or [-] pad repeatedly to set the desired time. Touching and holding the pad will cause the display to scroll rapidly through the increments.
4. Touch START. The display will count down the reheat time. When the cycle ends. "End" will appear in the display, and the end-of-cycle tones will sound.
5. Touch CANCEL/OFF or open the door to clear the display and/or stop reminder tones.

NOTE: Reheat cook power cannot be changed during a Reheat cycle.

To Change Reheat Time During Cooking: Touch [+] or [-] pad

repeatedly to set new time, or add time in 30-second increments by touching START - ADD 30 SEC pad. New time is set immediately.

To Reheat Manually: Follow directions in "Manual Cooking" section, and use 75% cooking power. See "Microwave Cooking Power" chart.

Popcorn

The cook times and power levels have been preset for commercially packaged 1.75 oz (50 g) microwave popcorn bags.

NOTE: During Popcorn function, as with all microwave cooking functions, the microwave oven should be attended at all times. Listen for popping to slow to 1 pop every 1 or 2 seconds, then stop the cycle.

- To avoid damage to the microwave oven, do not use regular paper bags or glassware.
- Pop only one package of popcorn at a time.
- Follow manufacturer's instructions when using a microwave popcorn popper.
- For best cooking results, do not try to pop unpopped kernels.
- Use fresh bags of popcorn for optimal results.
- Cooking results may vary by brand and fat content. For bag sizes not listed in this section, follow directions on the package.

NOTE: For best cooking results, we recommend using only the 1.75 oz (50 g) bag size, due to the compact cavity size.

To Use Popcorn:

1. Place popcorn bag on the turntable, and close the door.
2. Touch POPCORN. The default size of 1.75 oz will show in the display

3. Touch START. The display will count down the pop time. When the cycle ends. "End" will appear in the display, and the end-of-cycle tones will sound.
4. Touch CANCEL/OFF or open the door to clear the display and/or stop reminder tones.

NOTE: Popping times and cook power cannot be changed during an automatic Popcorn cycle.

General Cleaning

IMPORTANT: Before cleaning, make sure all controls are off and the microwave oven is cool. Always follow label instructions on cleaning products.

Soap, water and a soft cloth or sponge are suggested unless otherwise noted.

MICROWAVE OVEN CAVITY

To avoid damage to the microwave oven cavity, do not use soap-filled scouring pads, abrasive cleaners, steel-wool pads, gritty washcloths or some recycled paper towels.

The area where the microwave oven door and frame touch when closed should be kept clean.

Average soil

- Mild, nonabrasive soaps and detergents:

Rinse with clean water and dry with soft, lint-free cloth.

Heavy soil

- Mild, nonabrasive soaps and detergents:

Heat 1 cup (250 mL) of water for 2 to 5 minutes in microwave oven. Steam will soften soil.

Rinse with clean water and dry with soft, lint-free cloth.

Odors

- Lemon juice or vinegar:

Heat 1 cup (250 mL) of water with 1 tbs (15 mL) of either lemon juice or vinegar for 2 to 5 minutes in microwave oven.

Microwave Inlet Cover

To avoid arcing and microwave oven damage, the microwave inlet cover (see "Parts and Features") should be kept clean.

- Wipe with wet cloth.

MICROWAVE OVEN DOOR AND EXTERIOR

The area where the microwave oven door and frame touch when closed should be kept clean.

- Mild, nonabrasive soaps and detergents:

Rinse with clean water and dry with soft, lint-free cloth.

- Glass cleaner and paper towels or nonabrasive plastic scrubbing pad:

Apply glass cleaner to towel, not directly to surface.

CONTROL PANEL

- Sponge or soft cloth and water:

Dampen sponge with water and wipe panel. Dry with soft cloth.

- To avoid damage to the control panel, do not use chemical or abrasive cleansers.

TURNTABLE

Replace turntable immediately after cleaning. Do not operate the microwave oven without the turntable in place.

- Mild cleanser and scouring pad
- Dishwasher

TROUBLESHOOTING

Try the solutions suggested here first in order to avoid the cost of an unnecessary service call.

Nothing will operate

- **Has a household fuse blown, or has a circuit breaker tripped?** Replace the fuse or reset the circuit breaker. If the problem continues, call an electrician.

Microwave oven will not operate

- **Is the magnetron working properly?** Try to heat 1 cup (250 mL) of cold water for 2 minutes at 100% cooking power. If water does not heat, try the steps in the bullets below. If microwave oven still does not operate, call for service. See “Assistance or Service” section.
- **Is the door completely closed?** Firmly close door.
- **Is a packaging spacer (on some models) attached to the inside of the door?** Remove packaging spacer, then firmly close door.
- **Is the electronic microwave oven control set correctly?** See “Microwave Oven Control” section.
- **Is the Control Lock set?** See “Control Lock” section.
- **Does “door” appear in the display?** Open and close the microwave oven door, and then touch START. See “Start” section.

Microwave oven makes humming noise

- This is normal and occurs when the power supply in the magnetron cycles on.

Microwave oven door looks wavy

- This is normal and will not affect performance.

Turntable will not operate

- **Is the turntable properly in place?** Make sure turntable is correct side up and is sitting securely on the turntable support. See “Turntable” section.
- **Is the turntable support operating properly?** Remove turntable. Remove and clean turntable support and rollers. Replace turntable. Place 1 cup (250 mL) of water on the turntable, then restart microwave oven. If it still is not working, call for service. See “Assistance or Service” section. Do not operate the microwave oven without turntable and turntable support working properly.

Turntable alternates rotation directions

- This is normal and depends on motor rotation at beginning of cycle.

Display shows messages

- **Is the display showing “:”?** There has been a power failure, or the Clock time has been turned off. See “Display” section to clear display. See “Clock” section to reset or turn on Clock.

Display shows time countdown, but the microwave oven is not operating

- **Is the Timer in use?** See “Timer” section.

Cooking times seem too long

- **Is the cooking power set properly?** See “Microwave Cooking Power” section.
- **Are large amounts of food being heated?** Larger amounts of food need longer cooking times.
- **Is the incoming voltage less than that specified in “Electrical Requirements?”** Have a qualified electrician check the electrical system in the home.

Interference with radio, TV, cordless phone, etc.

- **Is the microwave oven plugged into the same outlet?** Try a different outlet for the electronic device.
- **Is the radio or TV receiver near the microwave oven?** Move the receiver away from the microwave oven, or adjust the radio or TV antenna.
- **Are the microwave oven door and sealing surfaces clean?** Make sure these areas are clean.
- **Is the cordless phone frequency 2.4 GHz?** Some 2.4 GHz-based cordless phones and home wireless networks may experience static or noise while the microwave oven is on. Use a corded phone or a different frequency cordless phone, or avoid using these items during microwave oven operation

Warning

This content is compiled from multiple sources and is provided for reference purposes only. It may not be complete or fully applicable to all situations. If you are unable to resolve your issue, please contact the product manufacturer or an authorized service provider for official support.

Document generated by [ManualsFile](#)