

FEATURE GUIDE



This manual covers several models. Your model may have some or all of the items listed.

WARNING: Food Poisoning Hazard

Do not let food sit in the oven for more than one hour before or after cooking.

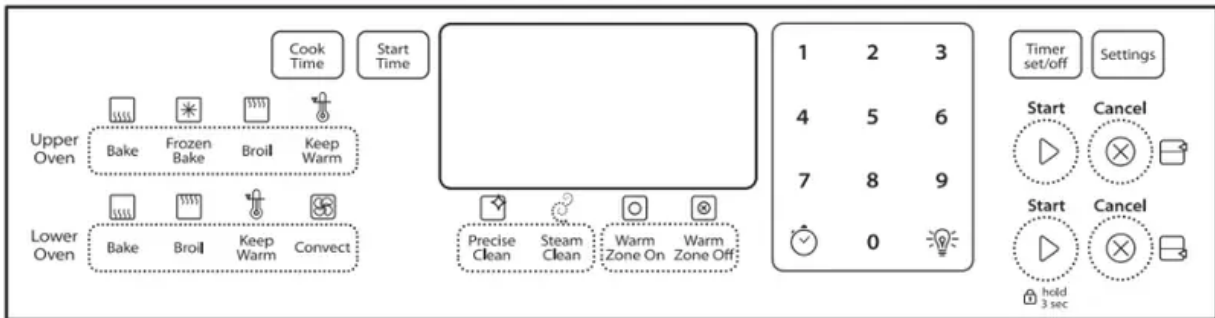
Doing so can result in food poisoning or sickness.



| Keypad | Feature | Instructions |
|---|----------------------------|--|
|  | Clock | This clock can use a 12- or 24-hour cycle. See "Electronic Oven Controls" section. <ol style="list-style-type: none"> 1. Press the Clock keypad. 2. Press "3" for AM or "6" for PM. 3. Press the number keypads to set the time of day. 4. Press the Clock keypad, START UPPER or START LOWER. |
|  | Oven cavity light | While the oven doors are closed, press the Oven Light keypad to turn the lights on and off. The oven lights will come on when an oven door is opened. |
| TIMER SET/OFF | Oven timer | The Timer can be set in hours or minutes up to 9 hours and 59 minutes. <ol style="list-style-type: none"> 1. Press TIMER SET/OFF. 2. Press the number keypads to set the length of time in hr-min. Leading zeros do not have to be entered. For example, for 2 minutes, enter "2." 3. Press TIMER SET/OFF to begin the countdown. If enabled, timer tones will sound at the end of countdown. The display will return to the time of day at the end of countdown. 4. Press TIMER SET/OFF to cancel the Timer and return to the time of day. Do not press the Cancel keypads because the oven will turn off. |
| START UPPER START LOWER | Cooking start | The Start keypads begin any oven function. If Start is not pressed within 2 minutes after pressing a keypad, the function is canceled and the time of day is displayed. |
| CANCEL UPPER CANCEL LOWER | Range function | The upper and lower Cancel keypads stop any corresponding oven function except the Clock, Timer, and Control Lock in the selected oven. |
| BAKE UPPER BAKE LOWER | Baking and roasting | <ol style="list-style-type: none"> 1. Press BAKE for the desired oven. 2. Press the number keypads to set the desired temperature. If the temperature entered is not in the range of the temperatures allowed, the minimum or maximum allowed temperature will be displayed. Enter a temperature in the allowable range. 3. (Lower oven, single-rack baking only) Press START LOWER. Rapid Preheat will begin. IMPORTANT: Rapid Preheat should be used only for single-rack baking. 4. (Multiple-rack baking) Press START for the desired oven. Press START for the desired oven again to cancel Rapid Preheat. 5. To change the temperature, repeat Step 2. Press START for the selected oven for the change to take effect. NOTE: If cooking in both ovens, press any number on the keypad, then follow the on-screen prompts to select the desired oven before entering temperature. 6. Press CANCEL for the selected oven when finished. |

| | | |
|--|-----------------------------|--|
| FROZEN BAKE (upper only) | Prepackaged food | <ol style="list-style-type: none"> Position the food on a flat rack in the oven on rack position 1. See the "Positioning Racks and Bakeware" section. NOTE: Cook only 1 package of frozen food at a time when using Frozen Bake™ Technology. Press FROZEN BAKE. Press the number keypad to select the desired food option. Press the number keypads to set the temperature as recommended on the food packaging. Press COOK TIME. Press the number keypads to set the maximum cook time as recommended on the food packaging. Press START. The range will calculate the best cook time based on the current oven temperature. NOTE: The cook time that appears in the display is the estimated required cook time as calculated by the oven control. It may be different than the time you entered. A beep will alert you to check the food's doneness with at least 2 minutes remaining on the timer. Follow the prompts on the display to select more time if desired. At the end of the cook time, a beep will alert you to check the food's doneness. Follow the prompts on the display to select more time if desired. Unless more time is selected, the bake element turns off. Press CANCEL when finished. |
| BROIL UPPER BROIL LOWER | Broiling | <ol style="list-style-type: none"> Press BROIL for the desired oven. Press the number keypads as instructed by the scrolling text to set the desired temperature level. Press START for the selected oven, and then allow the oven to preheat for 5 minutes. Position the cookware in the oven and leave the door open 4½" (11.4 cm) at the broil stop position. Press CANCEL for the selected oven when finished. |
| CONVECT (lower only) | Convection cooking | <ol style="list-style-type: none"> Press CONVECT until the desired mode is displayed, and then press START LOWER. Press the number keypads to set the desired temperature. If the temperature entered is not in the range of the temperatures allowed, the minimum or maximum allowed temperature will be displayed. Enter a temperature in the allowable range. Press START LOWER. To change the temperature, repeat Step 2. Press START LOWER for the change to take effect. NOTE: If cooking in both ovens, press any number on the keypad, then follow the on-screen prompts to select the desired oven before entering temperature. Press CANCEL LOWER when finished. |
| KEEP WARM UPPER KEEP WARM LOWER | Hold warm | <p>Food must be at serving temperature before placing it in the warmed oven.</p> <ol style="list-style-type: none"> Press KEEP WARM for the desired oven. Press the number keypads to set the desired temperature. If the temperature entered is not in the range of the temperatures allowed, the minimum or maximum allowed temperature will be displayed. Enter a temperature in the allowable range. Press START for the selected oven. To change the temperature, repeat steps 2 and 3. Press CANCEL for the selected oven when finished. |
| START TIME | Delayed start | <p>The Start Time keypad is used to enter the starting time for an oven function with a delayed start. Start Time should not be used for foods such as breads and cakes because they may not bake properly.</p> <p>To set a Timed Cook or a Delayed Timed Cook, see the "Cook Time" section.</p> |
| COOK TIME | Timed cooking | <p>Cook Time allows the oven to be set to turn on at a certain time of day, cook for a set length of time, and/or shut off automatically.</p> <p>To set a Cook Time or Delayed Cook Time, see the "Cook Time" section.</p> <p>NOTE: If cooking in both ovens, press any number on the keypad, then follow the on-screen prompts to select the desired oven before entering temperature.</p> |
| WARM ZONE ON/OFF | Warming zone | <p>Press WARM ZONE ON to select the warming element on the cooktop. Press START.</p> <p>Press WARM ZONE OFF to turn off the warming element.</p> |
| PRECISE CLEAN | Self-cleaning cycle | See the "Self-Cleaning Cycle" section. |
| START LOWER hold 3 sec. | Oven control lockout | <ol style="list-style-type: none"> Check that the ovens and timers are OFF. Press and hold START LOWER for 3 seconds. If enabled, a tone will sound, and "CONTROL LOCKED" will be displayed. Repeat to unlock. No keypads will function when the control is locked. |
| SETTINGS | Oven use functions | Enables you to personalize the audible tones and oven operation to suit your needs. See the "Oven Use" section. |

OVEN USE

Odors and smoke are normal when the oven is used the first few times or when it is heavily soiled.

IMPORTANT: The health of some birds is extremely sensitive to the fumes given off. Exposure to fumes may result in the death of certain birds. Always move birds to another closed and well-ventilated room.

Electronic Oven Controls

Control Display

The display will flash when powered up or after a power loss. Press CANCEL to clear. When the oven is not in use, the time of day is displayed.

Tones

Tones are audible signals, indicating the following:

One Tone

- Valid keypad press
- The oven is preheated (long tone).
- Kitchen timer (long tone with reminder tone every minute)
- The function has been entered.

Three Tones

- Invalid keypad press

Four Tones

- End of the cycle (with a reminder tone every minute)

Use the Settings key to change the tone settings.

Settings

Many features of the oven control can be adjusted to meet your personal needs. These changes are made using the Settings keypad.

Use the Settings keypad to scroll through the features that can be changed. Each press of the Settings keypad will advance the display to the next setting. After selecting the feature to be changed, the control will prompt you for the required input. Details of all of the feature changes are explained in the following sections.

Press CANCEL UPPER or CANCEL LOWER to exit Settings.

Fahrenheit and Celsius

The temperature is preset to Fahrenheit, but it can be changed to Celsius.

1. Press SETTINGS until "TEMP UNIT" is displayed.
2. The current setting will be displayed.
3. Press the "1" keypad to adjust the setting.

4. Press CANCEL UPPER or CANCEL LOWER to exit and display the time of day.

Audible Tones Disable

Turns off all tones, including the end-of-cycle tone and keypress tones.

1. Press SETTINGS until "SOUND" is displayed.
2. The current setting will be displayed.
3. Press the "1" keypad to adjust the setting.
4. Press CANCEL UPPER or CANCEL LOWER to exit and display the time of day.

Sound Volume

Sets the pitch of the tone to either high or low.

1. Press SETTINGS until "SOUND VOLUME" is displayed.
2. The current setting will be displayed.
3. Press the "1" keypad to adjust the setting.
4. Press CANCEL UPPER or CANCEL LOWER to exit and display the time of day.

End of Cycle Tone

Activates or turns off the tones that sound at the end of a cycle.

1. Press SETTINGS until "END TONE" is displayed.
2. The current setting will be displayed.
3. Press the "1" keypad to adjust the setting.
4. Press CANCEL UPPER or CANCEL LOWER to exit and display the time of day.

Keypress Tones

Activates or turns off the tones when a keypad is pressed.

1. Press SETTINGS until "KEYPRESS TONE" is displayed.
2. The current setting will be displayed.
3. Press the "1" keypad to adjust the setting.
4. Press CANCEL UPPER or CANCEL LOWER to exit and display the time of day.

Reminder Tones Disable

Turns off the short repeating tone that sounds every 1 minute after the end-of-cycle tones.

1. Press SETTINGS until "REMINDER TONE" is displayed.
2. The current setting will be displayed.
3. Press the "1" keypad to adjust the setting.
4. Press CANCEL UPPER or CANCEL LOWER to exit and display the time of day.

12/24 Hour Clock

1. Press SETTINGS until "12/24 HOUR" is displayed.

2. The current setting will be displayed.
3. Press the “1” keypad to adjust the setting.
4. Press CANCEL UPPER or CANCEL LOWER to exit and display the time of day.

12-Hour Shut-Off

The oven control is set to automatically shut off the oven 12 hours after the oven initiates a cook or clean function. This will not interfere with any timed or delayed cook functions.

1. Press SETTINGS until “12-HR SHUT-OFF” is displayed.
2. The current setting will be displayed.
3. Press the “1” keypad to adjust the setting.
4. Press CANCEL UPPER or CANCEL LOWER to exit and display the time of day.

Languages - Scrolling Display Text

Language options are English, Spanish and French.

1. Press SETTINGS until “LANGUAGE” is displayed.
2. The current setting will be displayed.
3. Press the number keypad to adjust the setting.
4. Press CANCEL UPPER or CANCEL LOWER to exit and display the time of day.

Oven Temperature Offset Control

IMPORTANT: Do not use a thermometer to measure oven temperature. Elements will cycle on and off as needed to provide consistent temperature, but they may run slightly hot or cool at any point in time due to this cycling. Most thermometers are slow to react to temperature change and will not provide an accurate reading due to this cycling.

The oven provides accurate temperatures; however, it may cook faster or slower than your previous oven, so the temperature can be adjusted to personalize it for your cooking needs. It can be changed to Fahrenheit or Celsius.

To Adjust Oven Temperature:

1. Press SETTINGS until “TEMP CALIB” is displayed.
2. The current setting will be displayed. Press the “1” keypad to toggle between the upper and lower ovens.
3. Press START UPPER or START LOWER to select the choice displayed in Step 2. Wait 10 seconds for the display to change or press START UPPER or START LOWER, and then continue with Step 4.
4. Press the “3” keypad to increase the temperature in 5°F (3°C) increments, or press the “6” keypad to decrease the temperature in 5°F (3°C) increments. The range is from -30°F to +30°F (-18°C to +18°C).
5. Press START UPPER or START LOWER.
6. Press CANCEL UPPER or CANCEL LOWER to exit and display the time of day.

Demo Mode

IMPORTANT: This feature is intended for use on the sales floor with a 120 V power connection and permits the control features to be demonstrated without the oven turning on. If this feature is activated, the oven will not heat.

1. Press SETTINGS until "DEMO MODE" is displayed.
2. The current setting will be displayed.
3. Press the "1" keypad to adjust the setting.
4. Press CANCEL UPPER or CANCEL LOWER to exit and display the time of day.

Energy Save

The Energy Save mode deactivates the display to reduce energy consumption. The setting will be activated after being idle for several minutes. Any mode may be used with the range in Energy Save by selecting the desired mode.

1. Press SETTINGS until "ENERGY SAVE" is displayed.
2. The current setting will be displayed.
3. Press the "1" keypad to adjust the setting.
4. Press CANCEL UPPER or CANCEL LOWER to exit and display the time of day.

Keep Warm

WARNING Food Poisoning Hazard

**Do not let food sit in the oven for more than one hour before or after cooking.
Doing so can result in food poisoning or sickness.**

IMPORTANT: Food must be at serving temperature before placing it in the warmed oven. Food may be held up to 1 hour; however, bread and casseroles may become too dry if left in the oven during the Keep Warm function. For best results, cover food. The Keep Warm feature allows hot-cooked foods to stay at serving temperature.

To Use:

1. Press KEEP WARM for the desired oven.
2. Press the number of keypads to set the desired temperature. If the temperature entered is not in the range of the temperatures allowed, the minimum or maximum allowed temperature will be displayed. Enter a temperature in the allowable range. **NOTE:** When cooking in a single oven, the temperature may be changed at any time by pressing the number keypads to enter the desired temperature, and then pressing START for the selected oven. When cooking in both ovens, press any number on the keypad, then follow the on-screen prompts to select the desired oven. Press the number of keypads to enter the desired temperature, and then press START for the selected oven.

3. Press START for the selected oven.
4. Place food in the oven.
5. Press CANCEL for the selected oven when finished.
6. Remove food from the oven.

To Cancel Keep Warm:

1. Press CANCEL for the selected oven.
2. Remove food from the oven.

Sabbath Mode

The Sabbath mode sets the oven to remain on in a bake setting until turned off.

When the Sabbath mode is set, only the Bake cycle will operate. All other cooking and cleaning cycles are disabled. No tones will sound and the displays will not indicate temperature changes. When the oven door is opened or closed, the oven light will not turn on or off and the oven heating elements will not turn on or off immediately.

To Enable Sabbath Mode Capability (one time only):

1. Press SETTINGS until "SABBATH" is displayed.
2. Press the "1" keypad. Sabbath mode can be activated for baking.
3. Press CANCEL UPPER or CANCEL LOWER to save the setting and exit to display the time of day.

NOTE: To disable the Sabbath mode, repeat steps 1 through 3 to change the status from "SABBATH ON" to "SABBATH OFF."

To Activate Sabbath Mode:

1. Press BAKE for the desired oven.
2. Press the number of keypads to set the desired temperature. If the temperature entered is not in the range of the temperatures allowed, the minimum or maximum allowed temperature will be displayed. Enter a temperature in the allowable range.
3. Press START for the selected oven. For timed cooking in Sabbath mode, press COOK TIME, and then press the number keypads to set the desired cook time. Press START for the selected oven.
4. (Optional) If Sabbath mode is to be used for both ovens, repeat steps 1 through 3 for the second oven.
5. Press SETTINGS. Three tones will sound. Then press "7." "SAb" will appear in the display.

To Adjust Temperature (when Sabbath mode is running in only one oven):

1. Press the number keypad as instructed by the scrolling text to select the new temperature. **NOTE:** The temperature adjustment will not appear on the display and no tones will sound. The scrolling text will be shown on the display as it was before the keypad was pressed.
2. Press START for the selected oven.

To Adjust Temperature (when Sabbath mode is running in both ovens):

1. Press BAKE for the desired oven.
2. Press the number keypad as instructed by the scrolling text to select the new temperature. **NOTE:** The temperature adjustment will not appear on the display and no tones will sound. The scrolling text will be shown on the display as it was before the keypad was pressed.
3. Press START for the selected oven.

To Deactivate Sabbath Mode:

Press SETTINGS, then press "7" to return to regular baking or press CANCEL to turn off the range.

Aluminum Foil

IMPORTANT: To avoid permanent damage to the oven bottom finish, do not line the oven bottom with any type of foil or liner. For best cooking results, do not cover the entire oven rack with foil because air must be able to move freely.

Positioning Racks and Bakeware

IMPORTANT: To avoid permanent damage to the porcelain finish, do not place food or bakeware directly on the oven door or bottom.

Racks

- Position racks before turning on the oven.
- Do not position racks with bakeware on them.
- Make sure the racks are level.
- Place food so it will not rise into the broil element. Allow at least 1/2" (1.3 cm) between the pans and the broil element.

To move a rack, pull it out to the stop position, raise the front edge, and then lift it out. Use the following illustrations and charts as a guide for positioning racks.

Rack Positions - Upper Oven

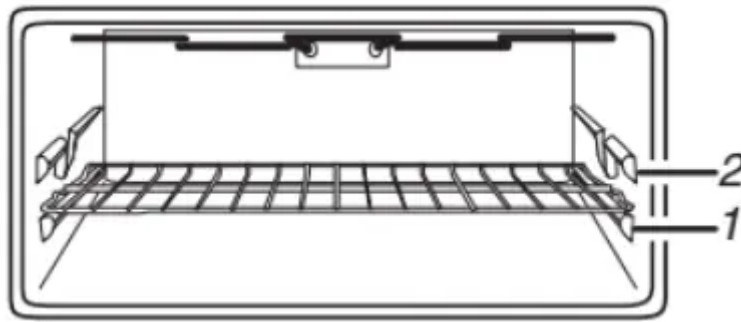

Baking and Broiling

| Food | Rack Position |
|-----------|---------------|
| All foods | 1 |

Rack Positions - Lower Oven

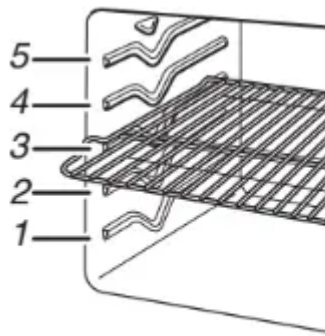

| Food | Rack Position |
|--|---------------|
| Large roasts or poultry | 1 |
| Roasted meats | 2 |
| Most baked goods, casseroles | 3 |
| Broiled meats, poultry, fish | 4 |
| Broiling/searing meats, hamburgers, steaks | 5 |

For hamburger patties to have a well-seared exterior and a rare interior in the lower oven, use a flat rack in rack position 5. Side 1 should cook for approximately $2^{1/2}$ to $3^{1/2}$ minutes. Side 2 should cook for approximately 4 to 5 minutes. Expect a moderate degree of smoke when broiling.

Multiple Rack Cooking

2-rack: Use rack positions 2 and 4 for regular baking.

2-rack (convection only): Use rack positions 2 and 4 for convection baking.

Baking Layer Cakes on 2 Racks

For best results when baking cakes on 2 racks, use rack positions 2 and 4 with the Convection Bake function. Place the cakes on the racks as shown.

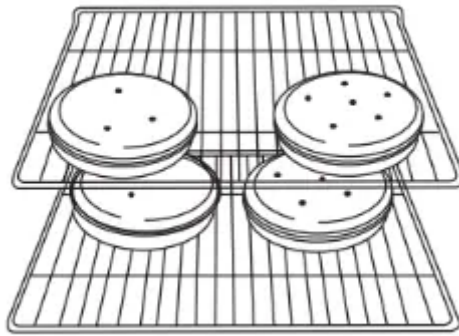

Baking Cookies on 2 Racks

For best results when baking cookies on 2 racks, use rack positions 2 and 4 with the Bake function.

Bakeware

To cook food evenly, hot air must be able to circulate. Allow 2" (5 cm) of space around bakeware and oven walls. Use the following chart as a guide.

| Number of Pan(s) | Position on Rack |
|------------------|------------------------------------|
| 1 | Center of rack |
| 2 | Side by side |
| 3 or 4 | Refer to the previous illustration |

Oven Vents

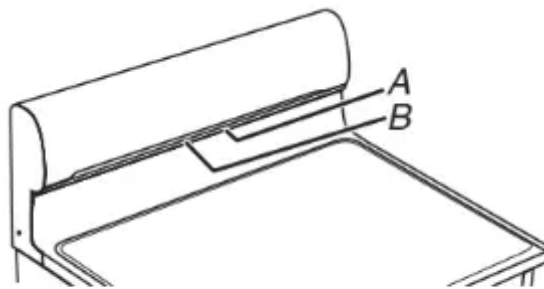

A. Upper oven vent
B. Lower oven vent

The oven vents release hot air and moisture from the ovens and should not be blocked or covered. Blocking or covering the vents will cause poor air circulation, affecting cooking and cleaning results. Do not set plastics, paper, or other items that could melt or burn near the oven vents.

Baking and Roasting

Preheating

When beginning a Bake cycle, the oven will begin preheating after the Start is pressed. The oven will take approximately 12 to 15 minutes to reach 350°F (177°C) with all of the oven racks provided with your oven inside the oven cavity. Higher temperatures will take longer to preheat. The preheat cycle rapidly increases the oven temperature. The actual oven temperature will go above your set temperature to offset the heat lost when your oven door is opened to insert food. This ensures that when you place your food in the oven, the oven will begin at the proper temperature. Insert your food when the preheat tone sounds. Do not open the door during preheat before the tone sounds.

Rapid Preheat

Rapid Preheat can be used to shorten the preheating time. Only one standard flat oven rack should be in the oven during Rapid preheating. Extra racks should be removed prior to starting Rapid Preheat. The preheating cycle should be completed before placing food in the oven. When the Rapid Preheat cycle is complete, the oven starts a normal Bake cycle.

IMPORTANT: Rapid Preheat should be used only for single-rack baking.

Oven Temperature

While in use, the oven elements will cycle on and off as needed to maintain a consistent temperature, but they may run slightly hot or cool at any point in time due to this cycling. Opening the oven door while in use will release the hot air and cool the oven which could impact the cooking time and performance. It is recommended to use the oven light to monitor the cooking progress.

NOTE: On models with convection, the convection fan may run in the non-convection Bake mode to improve oven performance.

AccuBake® Temperature Management System

The AccuBake® Temperature Management System electronically regulates the oven heat levels during preheating and baking to maintain a precise temperature range for optimal cooking results. The baked and broil elements or burners cycle on and off in intervals. On convection range models, the fan will run while preheating and may be cycled on and off for short intervals during the bake to provide the best results. This feature is automatically activated when the oven is in use.

Before baking and roasting, position racks according to the “Positioning Racks and Bakeware” section. When roasting, it is not necessary to wait for the oven preheat cycle to end before putting food in unless it is recommended in the recipe.

Frozen Bake™ Technology

Frozen Bake™ Technology can be used to cook prepackaged frozen food without needing to preheat the oven and without over-browning the food. There are 4 preprogrammed food options to choose from Pizza, Lasagna, Nuggets/Fries, and Pie. Frozen Bake™ Technology should only be used for these foods. Cook only 1 package at a time when using Frozen Bake™ Technology. Use

the recommended temperature and maximum recommended time from the packaging.

A beep will alert you to check the food's doneness before the cooking time is completed and again at the end of the cooking time. The display will prompt you to add to the cooking time or end the cycle.

Broiling

When broiling, preheat the oven for 5 minutes before putting food in unless recommended otherwise in the recipe. Leave the desired oven door open $4\frac{1}{2}$ " (114 mm) at the broil stop position to ensure proper broiling temperature. Position food on a grid in a broiler pan, and then place it in the center of the oven rack.

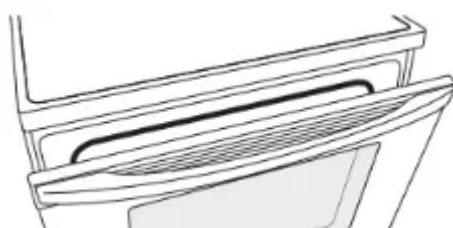

NOTE: Odors and smoke are normal the first few times the oven is used or if the oven is heavily soiled.

Changing the temperature when broiling allows more precise control when cooking. The lower the broil setting is, the slower the cooking. Thicker cuts and unevenly shaped pieces of meat, fish, and poultry may cook better at lower broil settings. Refer to the "Positioning Racks and Bakeware" section for more information. On lower settings, the broil element will cycle on and off to maintain the proper temperature.

- For best results, use a broiler pan and grid. It is designed to drain juices and help avoid spatter and smoke. If you would like to purchase a broiler pan, one may be ordered. See the "Accessories" section.

Lower Oven Convection Cooking

In a convection oven, the fan-circulated hot air continually distributes heat more evenly than the natural movement of air in a standard thermal oven. This movement of hot air helps maintain a consistent temperature throughout the oven, cooking foods more evenly, crisping surfaces while sealing in moisture, and yielding crustier bread.

If the oven door is opened during convection cooking, the fan will turn off immediately. It will come back on when the oven door is closed.

NOTE: The oven door must be closed for convection broiling.

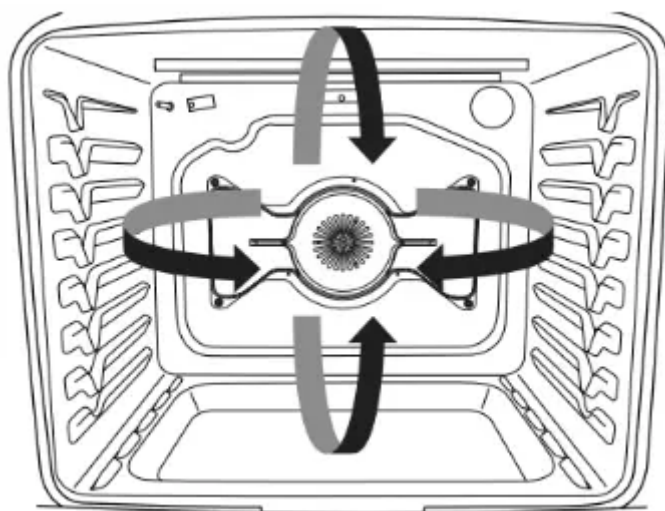

Position the racks according to the “Positioning Racks and Bakeware” section before starting convection cooking. With convection cooking, most foods can be cooked at a lower temperature or for a shorter length of time.

Cook Time

WARNING

Food Poisoning Hazard

Do not let food sit in the oven for more than one hour before or after cooking. Doing so can result in food poisoning or sickness.

To Set a Timed Cook:

1. Press the keypad for any cooking function except Self-Clean or Keep Warm.
2. Press the number of keypads to set the desired temperature. If the temperature entered is not in the range of the temperatures allowed, the minim or maximum allowed temperature will be displayed. Enter a temperature in the allowable range.
3. Press COOK TIME.
4. Press the number keypads to enter the length of time to cook.
5. Press START for the desired oven. The display will count down the time. When the time ends, the oven will shut off automatically. The temperature and/or time setting can be changed at any time by repeating steps 2 through 5. **NOTE:** If cooking in both ovens, press any number on the keypad, then follow the on-screen prompts to select the desired oven before entering the temperature.
6. Press CANCEL for the desired oven to clear the display.

To Set a Delayed Timed Cook:

NOTE: Delayed Timed Cook can only be used for one oven at a time.

1. Press START TIME.

2. Press the number “1” or “2” keypad to select the desired oven.
3. Press the number keypads to enter the number of hours and/ or minutes you want to delay the start time.
4. Press the keypad for any cooking function except Keep Warm and Frozen Bake™.
5. Press the number of keypads to set the desired temperature. If the temperature entered is not in the range of the temperatures allowed, the minimum or maximum allowed temperature will be displayed. Enter a temperature in the allowable range.
6. Press START for the desired oven or COOK TIME.
7. Press the number keypads to enter the length of time to cook.
8. Press START for the desired oven. When the start time is reached, the oven will automatically turn on. The temperature and/or time settings can be changed after the delay countdown by repeating steps 1 through 7. When resetting the time and temperature, it is necessary to press START for the desired oven between steps 4 and 5 to continue making changes. When the set cook time ends, the oven will shut off automatically.
9. Press CANCEL for the desired oven to clear the display.

RANGE CARE

Self-Cleaning Cycle

WARNING



Burn Hazard

Do not touch the oven during the Self-Cleaning cycle.

Keep children away from the oven during the Self-Cleaning cycle.

Failure to follow these instructions can result in burns.

IMPORTANT: The health of some birds is extremely sensitive to the fumes given off during the Self-Cleaning cycle. Exposure to fumes may result in the death of certain birds. Always move birds to another closed and well-ventilated room.

Keep the kitchen well-ventilated during the Self-Cleaning cycle to help get rid of heat, odors, and smoke.

Do not block the oven vent(s) during the Self-Cleaning cycle. Air must be able to move freely.

Depending on your model, see the “Oven Vent” or “Oven Vents” section.

Do not clean, rub, damage, or move the oven door gasket.

Prepare Range:

- Remove the broiler pan, grid, cookware, and bakeware, all cooking utensils, oven racks, aluminum foil, and, on some models, the temperature probe from the oven.
- Use a damp cloth to clean the inside door edge and the 1^{1/2}" (38 mm) area around the inside oven cavity frame, being certain not to move or bend the gasket.
- Wipe out any loose soil to reduce smoke and avoid damage.
At high temperatures, foods react with porcelain. Staining, etching, pitting, or faint white spots can result. This will not affect cooking performance.
- Remove plastic items from the cooktop because they may melt.

NOTE: The cooktop burners will not function during the Self-Cleaning cycle.

IMPORTANT:

- The oven temperature must be below 500°F (260°C) to program a clean cycle.
- Only 1 oven can be cleaned at a time.
- Both oven doors will lock when either oven is running the Self-Cleaning cycle.

How the Cycle Works

IMPORTANT: The heating and cooling of porcelain on steel in the oven may result in discoloring, loss of gloss, hairline cracks, and popping sounds.

The Precise Clean™ Self-Cleaning cycle is a “one-touch” step that uses very high temperatures and dissolves soil into powdery ash. The Precise Clean™ feature will automatically determine the length of cleaning time needed based on the number of times the oven has been used since the last Self-Cleaning cycle. The maximum clean time is 4 hours and the minimum clean time is 2 hours.

Once the oven has completely cooled, remove the ash with a damp cloth. To avoid breaking the glass, do not apply a cool damp cloth to the inner door glass before it has completely cooled. The oven light is disabled during the Self-Cleaning cycle.

To stop the Self-Cleaning cycle at any time, press CANCEL UPPER or CANCEL LOWER. If the temperature is too high, the oven doors will remain locked.

When “LOCK” shows in the display, the doors of the oven cannot be opened. To avoid damage to the doors, do not force the doors open when “LOCK” is displayed.

Before self-cleaning, make sure the doors are completely closed or the doors will not lock and the Self-Cleaning cycle will not begin.

NOTE: Only one oven can use the Self-Cleaning cycle at a time, and 12 hours must pass before the next Self-Cleaning cycle can begin.

The oven is preset for a 2-hour clean cycle; however, the time can be changed. Suggested clean times are 2 hours for light soil and between 3 hours and 4 hours for average to heavy soil.

Use the following chart as a guide to determine the desired cleaning level.

| Cleaning Level | Recommended Cleaning Time (Includes a 30-Minute Cool-Down Time) |
|-----------------------|--|
| 1 (Quick) | 2 hours |
| 2 | 2 hours 30 minutes |
| 3 | 3 hours |
| 4 (Reg) | 3 hours 30 minutes |
| 5 | 4 hours |
| 6 (Max) | 4 hours 30 minutes |

To Self-Clean:

1. Close the oven doors, and then press PRECISE CLEAN.
2. Press the number “1” or “2” keypad to select the desired oven to clean.
3. Press the number of keypads to enter the total cleaning time.
4. Press START for the selected oven. The oven doors will automatically lock. When the Self-Cleaning cycle is complete and the oven cools, the oven doors will unlock.
5. When the oven is completely cooled, remove the ash with a damp cloth.

To Delay Start Self-Clean:

1. Close the oven doors, and then press START TIME.
2. Press the number “1” or “2” keypad to select the desired oven.
3. Press the number of keypads to enter the desired amount of time by which you want to delay the start.
4. Press PRECISE CLEAN.
5. Press the number of keypads to enter the total cleaning time.
6. Press START for the selected oven. The oven doors will automatically lock after the Start Time countdown. When the Self-Cleaning cycle is complete and the oven cools, the oven doors will unlock.
7. When the oven is completely cooled, remove the ash with a damp cloth.

Steam Clean(on some models)

The Steam Clean feature is designed for light oven-cavity bottom cleaning on models that have hidden bake in both ovens.

Allow the range to cool to room temperature before using the Steam Clean feature. If your oven

cavity is above 100°F (38°C), “Oven Cooling” will appear in the display and the Steam Clean feature will not activate until it cools down.

- Remove all racks and accessories from the oven cavity.
- For best results, use distilled or filtered water.
- The Steam Clean feature will take a total of 20 minutes. A beep will sound at the end of the cycle.

IMPORTANT: Because the water in the oven bottom is hot, do not open the oven door during the Steam Clean cycle.

Press any CANCEL at any time to end the cycle. The display will return to the time of day.

Helpful Hints

- Once the Steam Clean cycle is complete, remove all remaining water in the bottom of the oven with a sponge or cloth.
- Wipe any remaining moisture from the oven door interior, oven cavity interior sides, and cooktop.
- Use a soft brush or nylon scrubber to wipe the oven interior. This may help with more stubborn stains.
- It is recommended to use distilled or filtered water as tap water may leave mineral deposits on the oven's bottom. Use a cloth soaked with vinegar or lemon juice to remove any mineral deposits that may be left after the Steam Clean cycle.
- If the oven is heavily soiled, use the Self-Clean cycle. The Steam Clean cycle may be used first to eliminate most of the debris, resulting in a more effective self-clean.

To Steam Clean:

1. Remove all racks and accessories from the oven cavity.
2. Press STEAM CLEAN.
3. Use the number keypad to select the desired oven.
4. Open the oven door of the selected oven and pour 16 oz (473 mL) of distilled or filtered water into the oven bottom. Then close the oven door.
5. Press START for the desired oven.
6. After 20 minutes, a beep will sound to signal the end of the cycle. Press CANCEL for the desired oven to clear the display.
7. Remove any excess water with a sponge or cloth and wipe down the oven interior. If needed, use a non-scratch copper scrubbing pad to remove stubborn soils.

General Cleaning

IMPORTANT: Before cleaning, make sure all controls are OFF and the oven and cooktop are cool. Always follow label instructions on cleaning products.

EXTERIOR PORCELAIN ENAMEL SURFACES (on some models)

Food spills containing acids, such as vinegar and tomato, should be cleaned as soon as the entire range is cool. These spills may affect the finish.

Cleaning Method:

- Glass cleaner, mild liquid cleaner, or nonabrasive scrubbing pad: Gently clean around the model/serial/rating plate because scrubbing may remove numbers.
- affresh® Kitchen and Appliance Cleaner Part Number W10355010 (not included): See the “Accessories” section for more information.

STAINLESS STEEL (on some models)

NOTE: To avoid damage to stainless steel surfaces, do not use soap-filled scouring pads, abrasive cleaners, Cooktop Cleaner, steel-wool pads, gritty washcloths, or abrasive paper towels. Damage may occur to stainless steel surfaces, even with one-time or limited use.

Cleaning Method:

Rub in direction of the grain to avoid damage.

- affresh® Stainless Steel Cleaner Part Number W10355016 (not included): See the “Accessories” section for more information.

METALLIC PAINT (on some models)

Do not use abrasive cleaners, cleaners with bleach, rust removers, ammonia, or sodium hydroxide (lye) because the paint surface may stain.

CERAMIC GLASS

Cleaning Method:

To avoid damaging the cooktop, do not use steel wool, abrasive powder cleansers, chlorine bleach, rust remover, or ammonia.

1. Remove food/residue with the Cooktop Scraper.

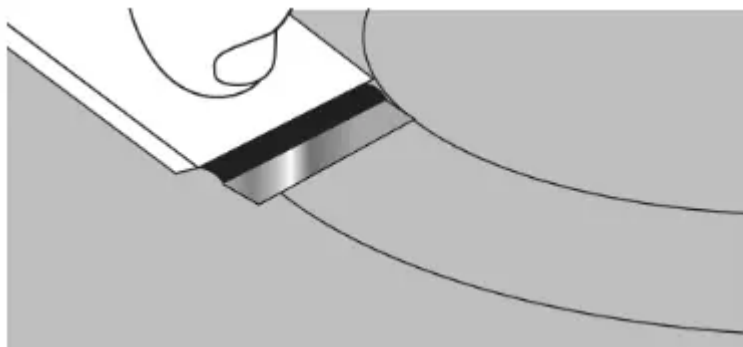

For best results, use the Cooktop Scraper while the cooktop is still warm but not hot to the touch. It is recommended to wear an oven mitt while scraping the warm cooktop. Hold the Cooktop

Scraper at approximately a 45° angle against the glass surface and scrape the residue. It will be necessary to apply pressure in order to remove the residue. Allow the cooktop to cool down completely before proceeding to Step 2.

2. Apply a few dime-sized drops of affresh® Cooktop Cleaner to the affected areas.

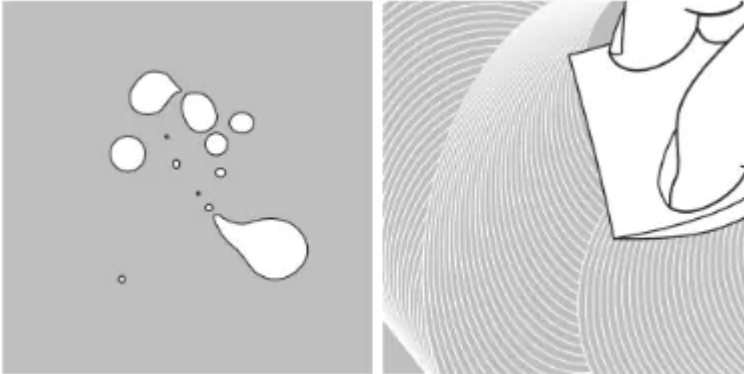

Rub affresh® Cooktop

Cleaner onto the cooktop surface with the blue Cooktop Cleaning Pad. Some pressure is needed to remove stubborn stains. Allow the cleaner to dry to a white haze before proceeding to Step 3.

3. Polish with a clean, dry cloth or a clean, dry paper towel.

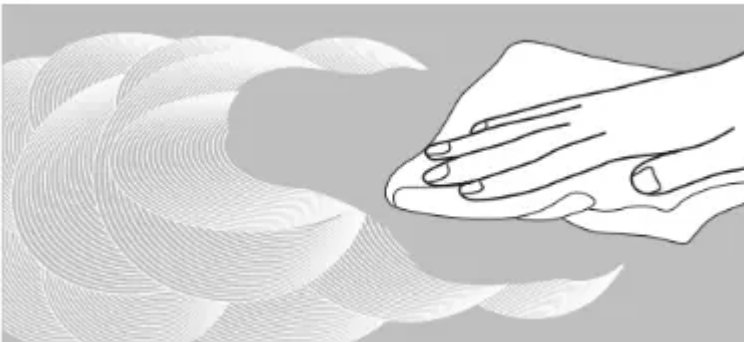

Repeat steps 1 through 3 as

necessary for stubborn or burned-on stains.

The Complete Cooktop Cleaner Kit is available for order and includes the following:

- Cooktop Scraper
- affresh® Cooktop Cleaner
- Blue Cooktop Cleaning Pads

See the “Accessories” section for part numbers and information on ordering.

COOKTOP CONTROLS

To avoid damage to the cooktop controls, do not use steel wool, abrasive cleansers, or oven cleaner.

To avoid damage, do not soak knobs. When replacing knobs, make sure knobs are in the OFF position.

On some models, do not remove seals under knobs.

Cleaning Method:

- Soap and water: Pull knobs straight away from the control panel to remove them.

CONTROL PANEL AND OVEN DOOR EXTERIOR

To avoid damage to the control panel, do not use abrasive cleaners, steel-wool pads, gritty washcloths, or abrasive paper towels.

Cleaning Method:

- Glass cleaner and soft cloth or sponge: Apply glass cleaner to soft cloth or sponge, not directly on the panel.
- affresh® Kitchen and Appliance Cleaner Part Number W10355010 (not included): See the “Accessories” section for more information.

OVEN RACKS

Cleaning Method:

- Steel-wool pad
- For racks that have discolored and are harder to slide, a light coating of vegetable oil applied to the rack guides will help them slide.

OVEN CAVITY

Do not use oven cleaners.

Food spills should be cleaned when the oven cools. At high temperatures, foods react with porcelain. Staining, etching, pitting, or faint white spots can result.

Cleaning Method:

- Clean cycle: See the “Self-Cleaning Cycle” section.

Oven Lights

The oven lights are standard 40-watt appliance bulbs. Before replacing, make sure the oven and cooktop are cool and the control knobs are in the OFF position.

To Replace:

1. Unplug the range or disconnect the power.
2. Turn the glass bulb cover in the back of the oven counterclockwise to remove it.
3. Turn the bulb counterclockwise to remove it from a socket.
4. Replace the bulb and then the bulb cover by turning clockwise.
5. Plug in the range or reconnect the power.

TROUBLESHOOTING

First, try the solutions suggested here. If you need further assistance or more recommendations that may help you avoid a service call, refer to the warranty page in this manual and scan the code there with your mobile device.

Contact us by mail with any questions or concerns at the address below:

In the U.S.A.:

Whirlpool Brand Home Appliances

Customer Experience Center

553 Benson Road

Benton Harbor, MI 49022-2692

In Canada:

Whirlpool Brand Home Appliances

Customer Experience Centre

200 - 6750 Century Ave.

Mississauga, Ontario L5N 0B7

Please include a daytime phone number in your correspondence.

Nothing will operate

- The power supply cord is unplugged:
 - Plug it into a grounded outlet.
- Household fuse is blown or a circuit breaker is tripped:
 - Replace the fuse or reset the circuit breaker. If the problem continues, call an electrician.
- The control displays an F9 or F9 E0 error code:
 - The electrical outlet in the home may be miswired. Contact a qualified electrician to verify the electrical supply.

The cooktop will not operate

- The control knob is not set correctly:
 - Push in the knob before turning to a setting.
- On ceramic glass models, the oven control lockout is set:
 - See the “Control Lock” keypad feature in the “Feature Guide” section.

Excessive heat around cookware on the cooktop

- Cookware is not the proper size:
 - Use cookware about the same size as the surface cooking area, element, or surface burner. Cookware should not extend more than 1/2" (1.3 cm) outside the cooking area.

Cooktop cooking results are not what expected

- Control knob set to incorrect heat level:
 - See the “Cooktop Use” section.

- The range is not level:
 - Level the range. See the Installation Instructions.

Cooktop element cycles on and off on Hi setting

- Element cycling due to a temperature limiter:
 - This is a normal operation. The element may cycle on and off to keep the cooktop from overheating.

The oven will not operate

- Delay Start is set:
 - See the “Cook Time” section.
- Control is locked:
 - Press and hold START LOWER for 3 seconds to unlock.
- Control is in Demo mode:
 - See the “Electronic Oven Controls” section. Demo mode is used for display models in a showroom.
- Electronic oven control set incorrectly:
 - See the “Electronic Oven Controls” section.

Oven temperature too high or too low

- Oven temperature needs adjustment:
 - See “Oven Temperature Control” in the “Electronic Oven Controls” section.

Oven indicator lights flash

- Power to the range is turned on or restored:
 - See “Control Display” in the “Electronic Oven Controls” section. If the indicator lights keep flashing, call for service. See the “Warranty” section for contact information.

Display shows messages

- Power failure (display shows flashing time):
 - Clear the display. On some models, reset the clock, if needed. See the “Clock” keypad feature in the “Feature Guide” section.
- Error code (display shows letter followed by the number):
 - Depending on your model, press CANCEL UPPER or CANCEL LOWER to clear the display. See “Control Display” in the “Electronic Oven Controls”

section. If it reappears, call for service. See the “Warranty” section for contact information.

The clean cycle did not work on all spills

- Several cooking cycles between clean cycles or spills on oven walls and doors:
 - Run additional clean cycles. affresh® Kitchen and Appliance Cleaner or affresh® Cooktop Cleaner can be used for stubborn soils. See the “Accessories” and “Self-Cleaning Cycle” sections for more information.

Oven cooking results are not what expected

- The range is not level:
 - Level the range. See the Installation Instructions.
- The set temperature was incorrect:
 - Double-check the recipe in a reliable cookbook.
- Oven temperature is calibrated incorrectly:
 - See “Oven Temperature Control” in the “Electronic Oven Controls” section.
- The oven was not preheated:
 - See the “Baking and Roasting” section.
- Racks were positioned improperly:
 - See the “Positioning Racks and Bakeware” section.
- Not enough air circulation around bakeware:
 - See the “Positioning Racks and Bakeware” section.
- Darker browning of food caused by dull or dark bakeware:
 - Lower oven temperature to 25°F (15°C) or move the rack to a higher position in the oven.
- Lighter browning of food caused by shiny or light-colored bakeware:
 - Move the rack to a lower position in the oven.
- Batter distributed unevenly in the pan:
 - Check that batter is level in the pan.
- Incorrect length of cooking time was used:
 - Adjust cooking time.
- The oven door was not closed:
 - Be sure that the bakeware does not keep the door from closing.

- The oven door was opened during cooking:
 - Oven peeking releases oven heat and can result in longer cooking times.
- The rack is too close to the baking burner, making baked items too brown on the bottom:
 - Move the rack to a higher position in the oven.
- Pie crusts browning too quickly:
 - Use aluminum foil to cover the edge of the crust and/or reduce the baking temperature.

Warning

This content is compiled from multiple sources and is provided for reference purposes only. It may not be complete or fully applicable to all situations. If you are unable to resolve your issue, please contact the product manufacturer or an authorized service provider for official support.