

REFRIGERATOR USE

Opening and Closing Doors

There are two refrigerator compartment doors. The doors can be opened and closed either separately or together.

There is a vertically-hinged seal on the left refrigerator door.

- When the left-hand refrigerator door is opened, the hinged seal automatically folds inward so that it is out of the way.
- When both doors are closed, the hinged seal automatically forms a seal between the 2 doors.

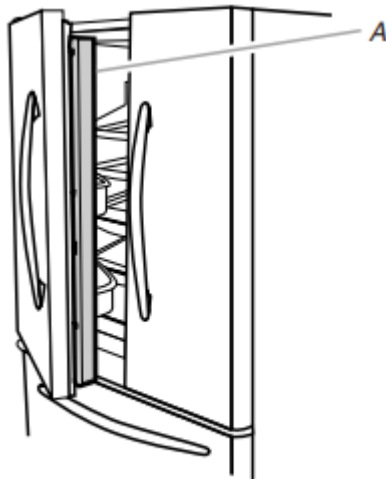

A. Hinged seal

Using the Controls

IMPORTANT:

- Wait 24 hours for your refrigerator to cool completely before adding food. If you add food before the refrigerator has cooled completely, your food may spoil.

NOTE: Adjusting the refrigerator and freezer temperature controls to a colder than recommended setting will not cool the compartments any faster.

- The recommended setting should be correct for normal household refrigerator use. The controls are set correctly when milk or juice is as cold as you like and when ice cream is firm.
- If the temperature is too warm or too cold in the refrigerator or freezer, first check the air vents to be sure they are not blocked before adjusting the controls.

Control Panel

Depending on your model, your refrigerator has either an internal control panel, located at the top of the refrigerator compartment, or an external control panel, located above the external water dispenser. Follow the instructions specific to your model.

Internal Control Panel

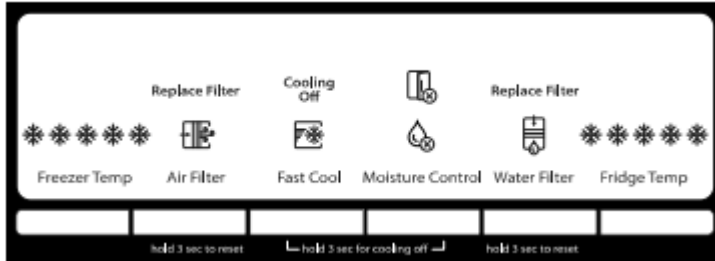

External Control Panel

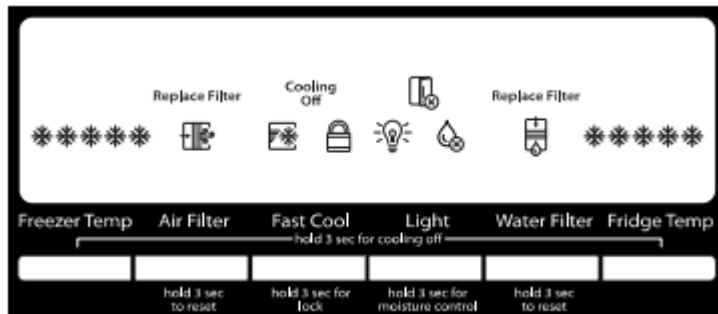

IMPORTANT (External Control only): The display screen on the dispenser control panel will turn off automatically and enter “sleep” mode when the control buttons and dispenser paddles have not been used for 2 minutes or more. While in “sleep” mode, the first press of a control button will only reactivate the display screen, without changing any settings. After reactivation, changes to any settings can then be made. If no changes are made within 2 minutes, the display will re-enter “sleep” mode.

- Touch any control button on the dispenser panel to activate the display screen.

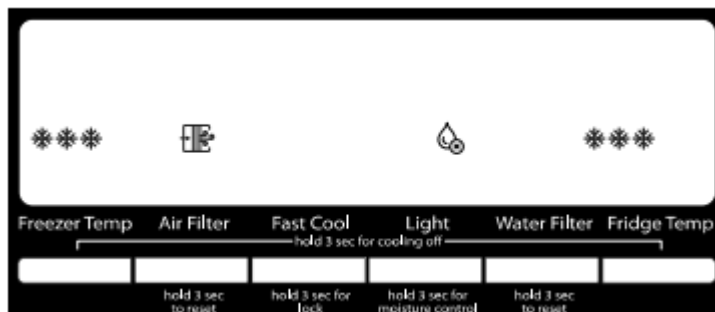

Temperature Control

For your convenience, the temperature control is preset at the factory. When you first install your refrigerator, make sure the control is still set to the recommended setting as shown.

Recommended Setting "3 Snowflakes"

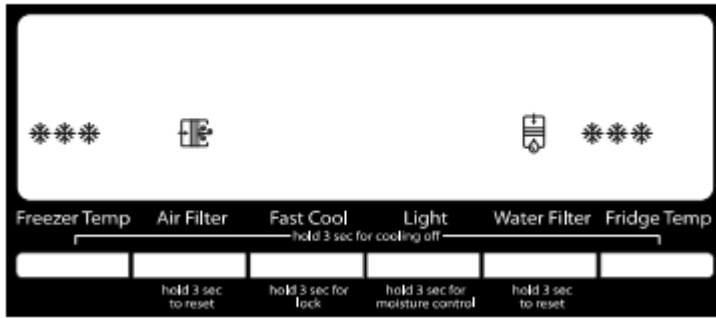

Adjusting the Controls

If you need to adjust the temperature in either the refrigerator or freezer compartment, use the settings listed in the following chart as a guide.

- Press the Temp button to display the desired number of snowflakes from 1 snowflake (least cold) to all 5 snowflakes (coldest).

NOTE: Except when starting the refrigerator, do not adjust the control more than one setting at a time. Wait 24 hours between adjustments for the temperature to stabilize.

CONDITION/REASON:	ADJUSTMENT:
REFRIGERATOR too warm	FRIDGE TEMP one more snowflake
FREEZER too warm/too little ice	FREEZER TEMP one more snowflake
REFRIGERATOR too cold	FRIDGE TEMP one less snowflake
FREEZER too cold	FREEZER TEMP one less snowflake

Cooling On/Off

Your refrigerator and freezer will not cool when cooling is turned off. Follow the directions specific to your model.

Internal Control Panel

- To turn cooling off, press and hold both the Fast Cool and Moisture Control buttons at the same time for 3 seconds. When cooling is OFF, "Cooling Off" will appear on the display screen.
- To turn cooling back on, press and hold both the Fast Cool and Moisture Control buttons at the same time for 3 seconds. When cooling is ON, "Cooling Off" will disappear and the previously selected settings will appear on the display screen.

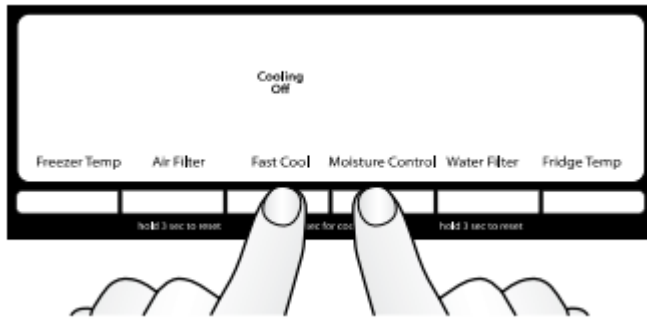

External Control Panel

- To turn cooling off, press and hold both the Freezer Temp and Fridge Temp buttons at the same time for 3 seconds. When cooling is off, “Cooling Off” will appear on the display screen.
- To turn cooling back on. Press and hold both the Freezer Temp and Fridge Temp buttons at the same time for 3 seconds. When cooling is on, “Cooling Off” will disappear and the previously selected settings will appear on the display screen.

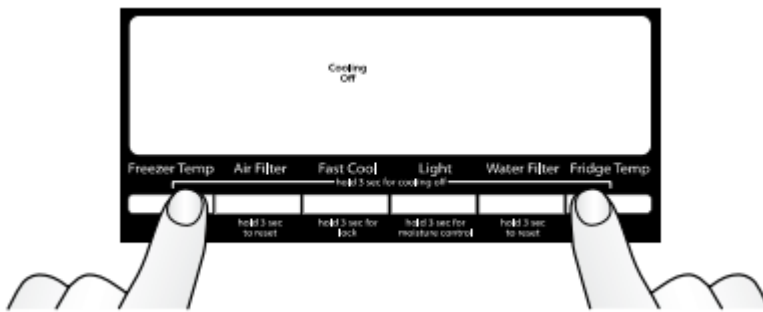

Additional Features

Door Open Alarm

- The Door Open icon lights up whenever either door is opened.



- When either door is open for 5 minutes and cooling is on, an alert tone will sound three times, and the Door Open icon will flash seven times. This pattern will repeat every 2 minutes until all the doors are closed properly. The feature then resets and will reactivate when either door is left open again for 5 minutes.

NOTES:

- To mute the audible alarm while keeping the doors open, such as while cleaning the inside of the refrigerator, press any button on the control panel. The alarm sound will be temporarily turned off, but the Door Open icon will still be displayed on the dispenser control panel.

- Both doors must be fully closed to turn off the Door Open icon.

Fast Cool

The Fast Cool feature assists during times of high refrigerator use, full grocery loads or temporarily warm room temperatures.

- Press FAST COOL to set the freezer and refrigerator to the coldest temperature settings. Press FAST COOL again to return to the selected temperature set point.

NOTES:

- The Fast Cool icon will be illuminated while the refrigerator is in Fast Cool mode.
- The Fast Cool feature will turn off automatically after 24 hours.



Moisture Control

The moisture control feature turns on a heater to help reduce moisture on the door hinge seal. Use in humid environments or when you notice moisture on the door hinge seal. The refrigerator uses more energy when Moisture Control is ON.

NOTE: The moisture control icon will light up to indicate the feature is ON.

To turn on/off the moisture control feature:

- Internal Control Panel - Press and hold MOISTURE CONTROL for 3 seconds.
- External Control Panel - Press and hold LIGHT for 3 seconds.



Water Filter Status Light and Reset

The filter reset control allows you to restart the water filter status tracking feature each time you replace the water filter. See “Water Filtration System.”

- Press and hold WATER FILTER for 3 seconds, to reset the water filter status to Good. The water filter icon will turn blue.



Air Filter Status Light and Reset

The filter reset control allows you to restart the air filter status tracking feature each time you replace the air filter. See “Install Air Filter.”

- Press and hold AIR FILTER for 3 seconds, to reset the air filter status to Good. The air filter icon will turn blue.



Water Dispenser (on some models)

IMPORTANT:

- Allow 3 hours for the refrigerator to cool down and chill water.
- Allow 24 hours to produce the first batch of ice. Discard the first three batches of ice produced.
- The dispensing system will not operate when the refrigerator door is open.

Flush the Water System

Air in the water dispensing system can cause the water dispenser to drip. After connecting the refrigerator to a water source or replacing the water filter, flush the water system.

Flushing the water dispensing system forces air from the water line and filter and prepares the water filter for use. Additional flushing may be required in some households.

NOTE: As air is cleared from the system, water may spurt out of the dispenser.

1. Using a sturdy container, depress and hold the water dispenser paddle for 5 seconds.
2. Release the dispenser paddle for 5 seconds.
3. Repeat steps 1 and 2 until water begins to flow.
4. Once water begins to flow, continue depressing and releasing the dispenser paddle (5 seconds on, 5 seconds off) until a total of 4 gal. (15 L) has been dispensed.

Dispense Water

IMPORTANT:

- The dispensing system will not operate when the refrigerator door is open.
- The display screen on the dispenser control panel will turn off automatically and enter “sleep” mode when the control buttons and dispenser paddles have not been used for 2 minutes or more. While in “sleep” mode, the first press of a control button will only reactivate the display screen, without changing any settings. After reactivation, changes to any settings can then be made. If no changes are made within 2 minutes, the display will re-enter “sleep” mode.

To dispense water:

1. Press a sturdy glass against the water dispenser paddle.
2. Remove the glass to stop dispensing.

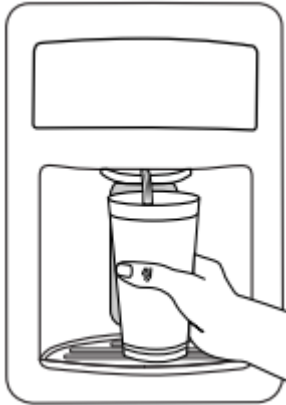

Dispenser Light

When you use the dispenser, the light will automatically turn on. If you want the light to be on continuously, you may turn on the light. The light icon will illuminate when the light is ON.



ON: Press LIGHT quickly to turn on the dispenser light.

OFF: Press LIGHT quickly to turn off the dispenser light.

NOTES:

- If you unintentionally press and hold the Light button for 3 seconds or longer, you will turn on the Moisture Control feature. If this happens, press and hold LIGHT for 3 seconds again to turn off the Moisture Control feature.
- The dispenser lights are LEDs that cannot be changed. If it appears that your dispenser lights are not working, see “Troubleshooting” for more information.

Dispenser Lock

The dispenser can be turned off for easy cleaning or to avoid unintentional dispensing by small children and pets.

NOTE: The lock feature does not shut off power to the refrigerator, to the ice maker, or to the dispenser light. It simply deactivates the controls and dispenser paddles. To turn off the ice maker, see “Ice Maker and Storage Bin.”

- Press and hold FAST COOL for 3 seconds to lock the dispenser.
- Press and hold FAST COOL for 3 seconds again to unlock the dispenser.

The lock icon will illuminate when the dispenser is locked.



Ice Maker

IMPORTANT: For models with a water filter, after connecting the refrigerator to a water source or replacing the water filter, fill and discard 3 full containers of ice to prepare the water filter for use.

Turning the Ice Maker On/Off

To turn on the ice maker, simply lower the wire shut-off arm.

To manually turn off the ice maker, lift the wire shut-off arm to the OFF (arm up) position and listen for the click.

NOTE: Your ice maker has an automatic shutoff. As ice is made, the ice cubes will fill the ice storage bin and the ice cubes will raise the wire shut-off arm to the OFF (arm up) position. Do not force the wire shut-off arm up or down.

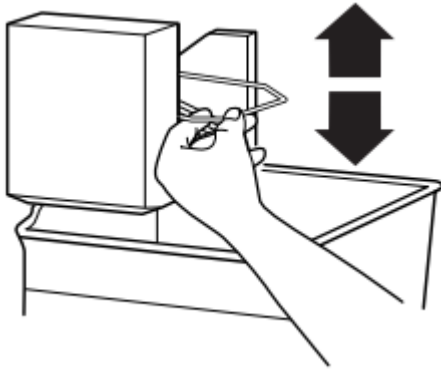

Ice Storage Bin

1. Wash the ice storage bin with mild soap and warm water.
2. Slide the ice storage bin under the ice maker and push it toward the back as far as it will go.
3. Lower the arm on the ice maker to the ON position.

NOTE: It usually takes approximately 24 hours for the ice maker to begin producing ice. You may notice the ice has an “off-taste.” If so, discard the first 3 batches of ice produced. After that the “off-taste” should be gone.

Ice Production Rate

- The ice maker should produce approximately 8 to 12 batches of ice in a 24-hour period. Allow 3 days to completely fill the ice container.
- To increase ice production, lower the freezer and refrigerator temperature. See “Using the Control(s).” Wait 24 hours between adjustments.

Remember

- The quality of your ice will be only as good as the quality of the water supplied to your ice maker. Avoid connecting the ice maker to a softened water supply. Water softener chemicals (such as salt) can damage parts of the ice maker and lead to poor quality ice. If a softened water supply cannot be avoided, make sure the water softener is operating properly and is well maintained.
- Do not use anything sharp to break up the ice in the bin. This can cause damage to the ice storage bin and the dispenser mechanism.
- Do not store anything on top of or in the ice maker or ice storage bin.

REFRIGERATOR FEATURES

NOTE: Your model may have some or all of these features.

Refrigerator Shelves

The shelves in your refrigerator are adjustable to match your individual storage needs.

Glass Shelves

To remove a shelf:

1. Remove items from the shelf.
2. Slide the shelf straight out to the stop.
3. Depending on your model, lift the back or front of the shelf past the stop. Pull the shelf out the rest of the way.

To replace a shelf:

1. Slide the back of the shelf into the track in the wall of the cabinet.
2. Guide the front of the shelf into the shelf track. Be sure to slide the shelf in all the way

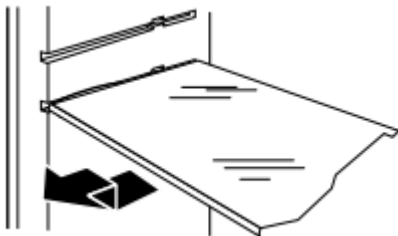

Foldaway Shelf (on some models)

To retract the foldaway shelf:

- Retract the foldaway section of the shelf by holding the front of the shelf with one hand and lifting up on the center front of the shelf. Then push back and down on the shelf until it slides beneath the back section of the shelf.

To replace the foldaway shelf:

- Replace the foldaway section of the shelf by holding the front of the shelf with one hand and pulling the center of the shelf until the foldaway section is returned to its full shelf position.

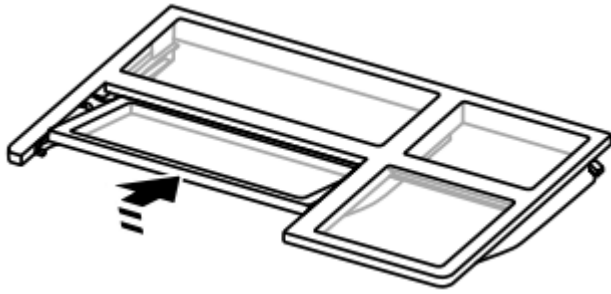

Pantry Drawer

Pantry Drawer

To remove and replace the pantry drawer:

1. Slide pantry drawer out to the stop.
2. Lift front of pantry drawer with one hand while supporting bottom of drawer with other hand. Slide drawer out the rest of the way.
3. Replace the drawer by sliding it back in fully past the drawer stop.

Pantry Drawer Cover

To remove and replace the pantry drawer cover:

1. Remove the pantry drawer.
2. From underneath, push up on the glass cover and pull it out.
3. Replace the pantry drawer cover by lowering it into place.
4. Replace the pantry drawer.

Pantry Drawer Control

The amount of air flowing through the pantry drawer affects the temperature inside the drawer.

The airflow control is located on the left side of the pantry drawer.

To adjust the airflow:

- Colder - Slide the control forward, toward the front of the pantry drawer. The airflow is open.

- Cold - Slide the control all the way toward the rear of the pantry drawer. The airflow is closed, as shown.

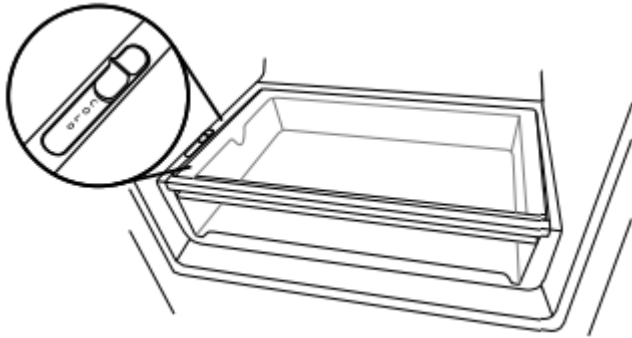

Crisper

Crisper Drawers

To remove and replace the crisper drawer:

1. Slide the crisper drawer straight out to the stop. Lift the front and slide the drawer out the rest of the way.
2. Replace the drawer by sliding the drawer in fully past the stop.

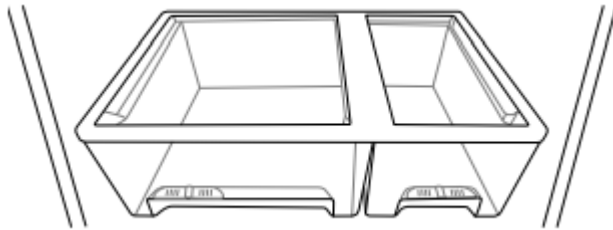

Crisper Cover

To remove and replace the glass crisper cover:

1. Pull the glass straight out.
2. Replace the glass by pushing it straight in.

Crisper Humidity Control (on some models)

You can control the amount of humidity in the moisture-sealed crisper. Adjust the control to any setting between LOW and HIGH.

LOW (open) lets moist air out of the crisper for best storage of fruits and vegetables with skins.

- Fruit: Wash, let dry and store in refrigerator in plastic bag or crisper. Do not wash or hull berries until they are ready to use. Sort and keep berries in original container in crisper, or store in a loosely closed paper bag on a refrigerator shelf.
- Vegetables with skins: Place in plastic bag or plastic container and store in crisper.

HIGH (closed) keeps moist air in the crisper for best storage of fresh, leafy vegetables.

- Leafy vegetables: Wash in cold water, drain and trim or tear off bruised and discolored areas. Place in plastic bag or plastic container and store in crisper.

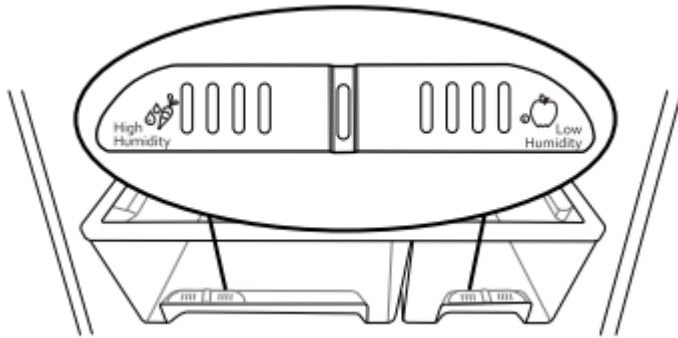

DOOR FEATURES

NOTE: Your model may have some or all of these features.

Condiment Bins

To remove and replace the condiment bins:

1. Tilt the bin by pulling it outward.
2. Remove the bin by lifting it upward off the glides.
3. Replace the bin by sliding it back onto the glides and then push it closed.

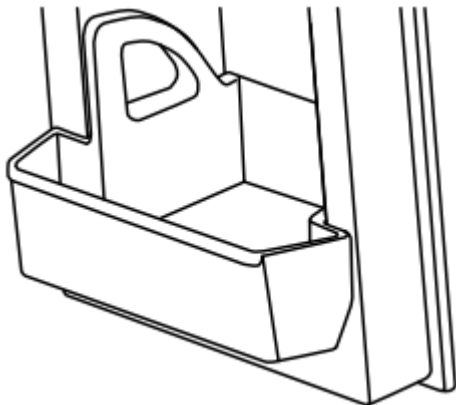

Fresh Bin (on some models)

To remove and replace the fresh bin:

1. Open the bin by grasping the top center lip of the bin and tilting the bin outward.
2. Remove the bin by grasping both sides of the bin and lifting the bin upward off the glides.
3. Replace the bin by sliding it back into its tilted position on the glides and then push it closed.

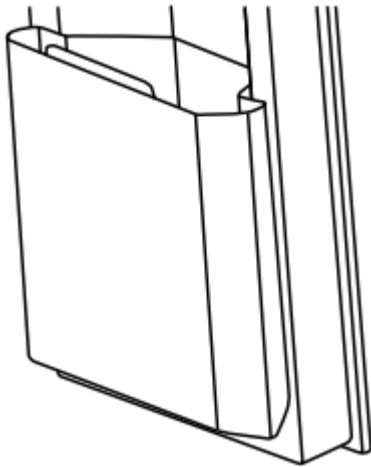

Half-Height Bin (on some models)

To remove and replace the half-height bin:

1. Tilt the bin by pulling it outward.
2. Remove the bin by lifting it upward off the glides.
3. Replace the bin by sliding it back onto the glides and then push it closed.

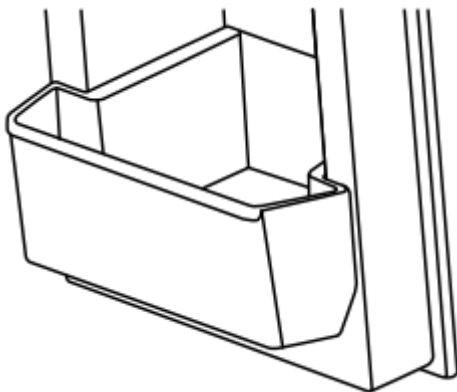

REFRIGERATOR CARE

Cleaning

Both the refrigerator and freezer sections defrost automatically. However, clean both sections about once a month to avoid buildup of odors. Wipe up spills immediately.

IMPORTANT:

- Because air circulates between both sections, any odors formed in one section will transfer to the other. You must thoroughly clean both sections to eliminate odors. To avoid odor transfer and drying out of food, wrap or cover foods tightly.

- For stainless steel models, stainless steel is corrosion-resistant and not corrosion-proof. To help avoid corrosion of your stainless steel, keep your surfaces clean by using the following cleaning instructions.

To Clean Your Refrigerator:

NOTE: Do not use abrasive or harsh cleaners such as window sprays, scouring cleansers, flammable fluids, muriatic acid, cleaning waxes, concentrated detergents, bleaches or cleansers containing petroleum products on exterior surfaces (doors and cabinet), plastic parts, interior and door liners or gaskets. Do not use paper towels, scouring pads, or other harsh cleaning tools.

1. Unplug refrigerator or disconnect power.
2. Hand wash, rinse, and dry removable parts and interior surfaces thoroughly. Use a clean sponge or soft cloth and a mild detergent in warm water.
3. Clean the exterior surfaces.

Painted metal: Wash painted metal exteriors with a clean, soft cloth or sponge and a mild detergent in warm water. Rinse surfaces with clean, warm water and dry immediately to avoid water spots.

Stainless steel: Wash stainless steel surfaces with a clean, soft cloth or sponge and a mild detergent in warm water. Rinse surfaces with clean, warm water and dry immediately to avoid water spots.

NOTE: When cleaning stainless steel, always wipe in the direction of the grain to avoid cross-grain scratching.

4. There is no need for routine condenser cleaning in normal home operating environments. If the environment is particularly greasy or dusty, or there is significant pet traffic in the home, the condenser should be cleaned every 2 to 3 months to ensure maximum efficiency.

If you need to clean the condenser:

- Remove the base grille.
- Use a vacuum cleaner with a soft brush to clean the grille, the open areas behind the grille and the front surface area of the condenser.
- Replace the base grille when finished.

5. Plug in refrigerator or reconnect power.

Changing the Light Bulbs

IMPORTANT:

- Not all appliance bulbs will fit your refrigerator. Be sure to replace the bulb with an appliance bulb of the same size, shape and wattage.
- To ensure optimum refrigerator performance, replace light bulbs as soon as they burn out.

Refrigerator Compartment Light

The lighting located at the top of the refrigerator compartment never needs to be replaced. If the lights do not illuminate when the door is opened, call for assistance or service. In the U.S.A., call 1-800-253-1301. In Canada, call 1-800-807-6777.

Freezer Compartment Light (on some models)

1. Unplug the refrigerator or disconnect power.
2. Remove the light shield (on some models).
 - Top of the freezer compartment - Slide the light shield toward the back of the compartment to release it from the light assembly.

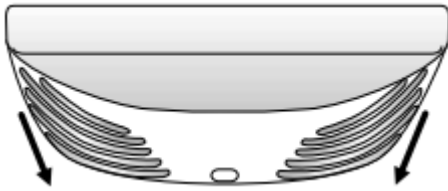

3. Replace the burned-out bulb with an appliance bulb(s) no greater than 25 watts.
4. Replace the light shield.
5. Plug in refrigerator or reconnect power.

TROUBLESHOOTING

Operation



PROBLEM	POSSIBLE CAUSES	SOLUTIONS
The refrigerator will not operate	Check electrical supply	<p>Plug the power cord into a grounded 3 prong outlet.</p> <p>Do not use an extension cord.</p> <p>Make sure there is power to the outlet. Plug in a lamp to see if the outlet is working.</p> <p>Reset a tripped circuit breaker. Replace any blown fuses. NOTE: If problems continue, contact an electrician.</p>
	Check controls	Make sure the controls are turned on. See "Using the Controls."
	New installation	<p>Allow 24 hours following installation for the refrigerator to cool completely.</p> <p>NOTE: Adjusting the temperature controls to the coldest setting will not cool either compartment quicker</p>
The motor seems to run too much	High-efficiency compressor and fans	This is normal. Larger, more efficient refrigerators run longer.
	The room or outdoor temperature is hot	It is normal for the refrigerator to work longer under these conditions. For optimum performance, place the refrigerator in an indoor, temperature-controlled environment. See "Location Requirements."
	A large amount of warm food has been recently added	Warm food will cause the refrigerator to run longer until the air cools to the desired temperature.
	The door(s) are opened too frequently or for too long	Warm air entering the refrigerator causes it to run more. Open the door less often.

	The refrigerator door or freezer drawer is ajar	Make sure the refrigerator is level. See “Door Closing and Door Alignment.” Keep food and containers from blocking the door.
	The refrigerator control is set too cold	Adjust the refrigerator control to a less cold setting until the refrigerator temperature is as desired. See “Using the Controls.”
	The door or drawer gasket is dirty, worn, or cracked	Clean or change the gasket. Leaks in the door seal will cause the refrigerator to run longer in order to maintain desired temperatures.
The lights do not work	A light bulb is loose in the socket or burned out	Tighten or replace the light bulb. See “Changing the Light Bulbs.”
	The dispenser light is set to OFF	On some models, the dispenser light will operate only when a dispenser paddle is pressed. If you want the dispenser light to stay on continuously, see “Water Dispenser.”
	The control is set to Sabbath Mode (on some models)	Turn off Sabbath Mode. See “Using the Controls.”



Noise

PROBLEM	POSSIBLE CAUSES	SOLUTIONS
<p>The refrigerator seems noisy</p> <p>Below are listed some normal sounds with explanations.</p>	<p>The compressor in your new refrigerator regulates temperature more efficiently while using less energy, and operates quietly. Due to the reduction in operating noise, you may notice more intermittent noises.</p>	
<p>Sound of the compressor running longer than expected</p>	<p>High-efficiency compressor and fans</p>	<p>This is normal. Larger, more efficient refrigerators run longer.</p>
<p>Pulsating/Whirring</p>	<p>Fans/compressor adjusting to optimize performance during normal compressor operation</p>	<p>This is normal.</p>
<p>Popping</p>	<p>Contraction/expansion of inside walls, especially during initial cool-down</p>	<p>This is normal.</p>
<p>Hissing/Dripping</p>	<p>Flow of refrigerant, or flow of oil in the compressor</p>	<p>This is normal.</p>
<p>Vibration</p>	<p>The refrigerator may not be steady</p>	<p>Adjust the leveling screws and lower the leveling foot firmly against the floor. See “Door Closing and Door Alignment.”</p>
<p>Rattling/Banging</p>	<p>Movement of the water lines against the refrigerator cabinet, or of items placed on top of the refrigerator cabinet</p>	<p>Move excess water line away from the refrigerator cabinet or fasten excess tubing to the cabinet. See “Connect the Water Supply,” or remove items from the top of the refrigerator.</p>
<p>Sizzling</p>	<p>Water dripping on the heater during defrost cycle</p>	<p>This is normal.</p>



Water running/Gurgling	May be heard when ice melts during the defrost cycle and water runs into the drain pan	This is normal.
Buzzing	Heard when the water valve opens to fill the ice maker	This is normal.
Creaking/Cracking	May be heard as ice is being ejected from the ice maker mold	This is normal.
Ker-plunk	May be heard when the ice falls into the ice storage bin	This is normal.



Temperature and Moisture



PROBLEM	POSSIBLE CAUSES	SOLUTIONS
Temperature is too warm	The refrigerator has just been installed	Allow 24 hours following installation for the refrigerator to cool completely.
	Cooling is turned off	Turn on cooling. See "Using the Controls."
	The controls are not set correctly for the surrounding conditions	Adjust the controls a setting colder. Check the temperature in 24 hours. See "Using the Control(s)."
	The door(s) are opened often or not closed completely	Allows warm air to enter refrigerator. Minimize door openings and keep doors fully closed.
	A large load of food was recently added	Allow several hours for refrigerator to return to normal temperature.
Temperature is too cold in the refrigerator/crisper	The refrigerator air vent(s) are blocked	If the air vent located in the top, left, rear corner of the refrigerator compartment is blocked by items placed directly in front of it, the refrigerator will get too cold. Move items away from the air vent.
	The controls are not set correctly for the surrounding conditions	Adjust the controls a setting warmer. Check the temperature in 24 hours. See "Using the Controls."
	The ice storage bin is not in the correct position	See "Ice Maker."
Temperature is too cold in the pantry drawers	The control is not set correctly for the items stored in drawer	Adjust the control setting. See "Refrigerator Features."
There is interior moisture buildup	The room is humid	A humid environment contributes to moisture buildup.

NOTE: Some moisture buildup is normal.	The door(s) are opened often or not closed completely	Allows humid air to enter the refrigerator. Minimize door openings and close doors completely.
	The door is blocked open	Move food packages away from door.
	A bin or shelf is in the way	Push bin or shelf back into the correct position.
	Storing liquid in open containers	This adds humidity to the refrigerator interior. Keep all containers tightly covered.
There is frost/ice buildup in the freezer compartment	The doors are opened often or left open	Minimize door openings and keep doors fully closed.
	Poor door seal	Ensure door seals are making full contact with the refrigerator cabinet to allow for an adequate seal.
	Temperature controls are not set correctly	See "Using the Controls" for recommended temperature settings.



Ice and Water

PROBLEM	POSSIBLE CAUSES	SOLUTIONS
The ice maker is not producing ice or is not producing enough ice	The refrigerator is not connected to a water supply or the water supply shut-off valve is not turned on	Connect refrigerator to water supply and turn water shutoff valve fully open.
	There is a kink in the water source line	A kink in the line can reduce water flow. Straighten the water source line.
	The ice maker is not turned on	Make sure the ice maker is ON. See “Ice Maker.”
	The refrigerator has just been installed	Wait 24 hours after ice maker installation for ice production to begin. Wait 3 days for full ice production.
	The refrigerator door is not closed completely	Close the door firmly. If it does not close completely, see “The doors will not close completely.”
	A large amount of ice was recently removed	Allow 24 hours for ice maker to produce more ice.
	An ice cube is jammed in the ice maker ejector arm	Remove ice from the ejector arm with a plastic utensil. NOTE: On some models, press the lever which opens the ice maker door to access the ejector arm.
	A water filter is installed on the refrigerator	Remove the water filter and operate the ice maker. If ice volume improves, then the filter may be clogged or incorrectly installed. Replace filter or reinstall it correctly.
	A reverse osmosis water filtration system is connected to your cold water supply	This can decrease water pressure. See “Water Supply Requirements.”

<p>The ice cubes are hollow or small</p> <p>NOTE: This is an indication of low water pressure.</p>	<p>The water shut-off valve is not fully open</p>	<p>Turn the water shut-off valve fully open.</p>
	<p>There is a kink in the water source line</p>	<p>A kink in the line can reduce water flow. Straighten the water source line.</p>
	<p>A water filter is installed on the refrigerator</p>	<p>Remove filter and operate ice maker. If ice quality improves, then the filter may be clogged or incorrectly installed.</p> <p>Replace filter or reinstall it correctly.</p>
	<p>A reverse osmosis water filtration system is connected to your cold water supply</p>	<p>This can decrease water pressure. See "Water Supply Requirements."</p>
	<p>Questions remain regarding water pressure</p>	<p>Call a licensed, qualified plumber.</p>
<p>Off-taste, odor or gray color in the ice or water</p>	<p>Recently installed or replaced plumbing connections (New plumbing connections can cause discolored or off-flavored ice and water.</p>	<p>Discard the ice and wash the ice storage bin. Flush the water system with 4 gal. (15 L) of water. Allow 24 hours for the ice maker to make new ice, and discard the first 3 batches of ice produced.</p>
	<p>The ice has been stored too long</p>	<p>Discard ice. Wash ice storage bin. Allow 24 hours for ice maker to make new ice.</p>
	<p>The water has been stored too long</p>	<p>Dispense at least 1 qt (1 L) of water per week to maintain a fresh supply.</p>
	<p>Odor from stored food has transferred to the ice</p>	<p>Use airtight, moisture proof packaging to store food.</p>
	<p>There are minerals (such as sulfur) in the water</p>	<p>A water filter may need to be installed to remove the minerals.</p>



	There is a water filter installed on the refrigerator	Gray or dark discoloration in ice may indicate that the water filtration system needs additional flushing. Flush the water system after installing and before using a new water filter. See “Water Dispenser” for water filter flushing instructions.
	The water filter needs to be replaced	Replace the disposable water filter at least every 6 months or when indicated. See “Water Filtration System.”
The water dispenser will not operate properly	The refrigerator is not connected to a water supply or the water supply shut-off valve is not turned on	Connect the refrigerator to the water supply and turn the water shut-off valve fully open.
	There is a kink in the water source line	A kink in the water line can reduce water flow from the water dispenser and result in hollow or irregular shaped ice. Straighten the water source line.
	The refrigerator has just been installed	Flush and fill the water system. See “Water Dispenser.”
	The water pressure to the house is not at or above 30 psi (207 kPa)	The water pressure to the house determines the flow from the dispenser. See “Water Supply Requirements.”
	A reverse osmosis water filtration system is connected to your cold water supply	A reverse osmosis water filtration system can decrease water pressure. See “Water Supply Requirements.”
	A water filter is installed on the refrigerator	Remove filter and operate dispenser. If water flow increases, the water filter may be clogged or incorrectly installed. Replace filter or reinstall it correctly.



	The refrigerator door is not closed completely (on some models)	Close the door firmly. If it does not close completely, see “The doors will not close completely.”
	The refrigerator doors were recently removed	Make sure the water dispenser wire/ tube assembly has been properly reconnected at the top of the refrigerator door. See “Remove and Replace Refrigerator Doors and Drawer Front.”
Water is leaking or dripping from the dispenser system NOTE: A few drops of water after dispensing is normal.	The glass was not held under the dispenser long enough	Hold the glass under the dispenser 2 to 3 seconds after releasing the dispenser lever.
Water continues to drip from the dispenser beyond the first few drops.	The refrigerator has just been installed	Flushing the water system removes the air from the lines which causes the water dispenser to drip. Flush the water system. See “Water Dispenser.”
	The water filter was recently changed	Flushing the water system removes the air from the lines which causes the water dispenser to drip. Flush the water system. See “Water Dispenser.”
Water is leaking from the back of the refrigerator	The water line connections were not fully tightened	See “Connect the Water Supply.”
	Recently removed the doors and did not fully tighten water line connection	See “Remove and Replace Refrigerator Doors and Drawer Front.”
Water from the dispenser is warm	The refrigerator has just been installed	Allow 24 hours after installation for the water supply to cool completely.

NOTE: Water from the dispenser is only chilled to 50°F (10°C).	A large amount of water was recently dispensed	Allow 3 hours for the water supply to cool completely.
	Water has not been recently dispensed	The first glass of water may not be cool. Discard the first glass of water dispensed.
	The refrigerator is not connected to a cold water pipe	Make sure the refrigerator is connected to a cold water pipe. See "Water Supply Requirements."

Doors

PROBLEM	POSSIBLE CAUSES	SOLUTIONS
The door(s) or drawer will not close completely	The door or drawer is blocked open	Move food packages away from door(s). Remove ice or other items which have fallen onto the floor of the freezer compartment.
	A bin or shelf is in the way	Push bin or shelf back into the correct position.
	Recently installed	Remove all packaging materials.
The doors are difficult to open	The door gaskets are dirty or sticky	Clean gaskets and contact surfaces with mild soap and warm water. Rinse and dry with soft cloth.
The doors appear to be uneven	The doors need to be aligned or the refrigerator needs to be leveled	See "Door Closing and Door Alignment."
The doors do not open or close as expected	The refrigerator tilt needs to be adjusted	Adjust the refrigerator tilt. See "Door Closing and Door Alignment."

Warning

This content is compiled from multiple sources and is provided for reference purposes only. It may not be complete or fully applicable to all situations. If you are unable to resolve your issue, please contact the product manufacturer or an authorized service provider for official support.

Document generated by [ManualsFile](#)

