

Using the Oven

Oven Controls

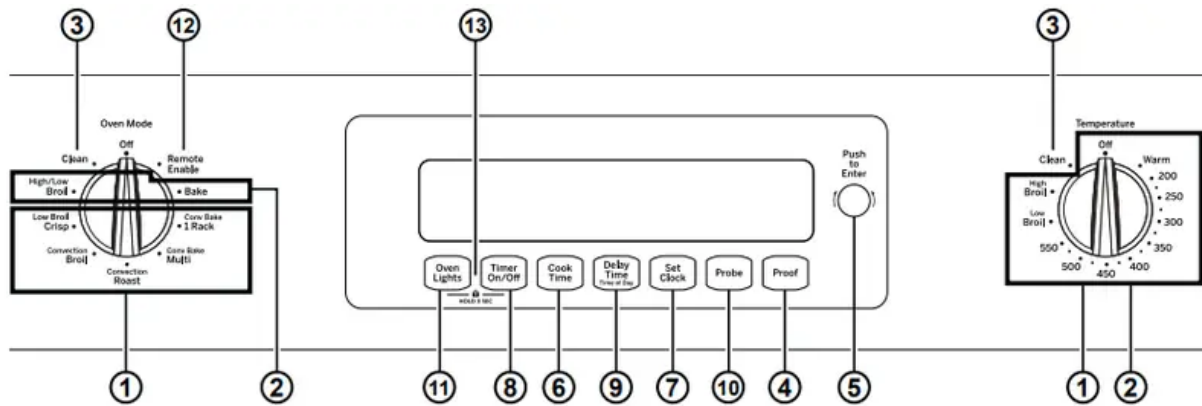

1. Convection Cooking Modes: Convection cooking modes use increased air circulation to improve performance. The type of benefit depends on the mode. Your oven has the following convection cooking modes: Bake 1 Rack, Bake Multi, Broil, Roast and Low Broil Crisp. Select the cooking mode and then set the temperature to start cooking. See the Cooking Modes section for more information.

2. Traditional Cooking Modes: Your oven has the the following traditional cooking modes: Bake and High/Low Broil. Select the cooking mode and then set the temperature to start cooking. See the Cooking Modes section for more information.

3. Clean: Your oven has two cleaning modes: Self Clean and Steam Clean. See the Cleaning the Oven section for important information about using these modes.

4. Proof: Use this feature to assist with rising bread doughs. See the Cooking Modes section for more information

5. Mini Knob: Rotate this knob to increase or decrease time setting and then press the knob to confirm the setting when using Set Clock, Cook Time, Delay Time, and Timer On/Off. Rotate this knob to increase or decrease self Self-Clean time and press the knob to confirm the setting or press the knob to toggle between self-clean and steam clean. Rotate the knob to increase or decrease the temperature setting and press the knob to confirm the setting when using the probe feature.

6. Cook Time: Counts down cooking time and turns off the oven when the cooking time is complete. Press the Cook Time pad, rotate the mini knob to program a cooking time in hours and minutes, then press the mini knob to set the cook time. This feature can only be used with Traditional Bake, Convection Bake 1 Rack, Convection Bake Multi, and Convection Roast.

7. Set Clock: Sets the oven clock time. Press the Set Clock pad and rotate the mini knob to program the clock. Press the mini knob to set the time and then rotate the mini knob to select AM or PM. Press the mini knob to save the time.

8. Timer On/Off: Works as a countdown timer. Press the Timer On/Off pad and rotate the mini knob to program the time in hours and minutes then press the mini knob to start the timer. The oven will continue to operate when the timer countdown is complete. To turn the timer off press the Timer On/Off pad and rotate the mini knob till the timer reads 0:00 then press the mini knob to clear the timer.

9. Delay Time: Delays when the oven will turn on. Use this to set a time when you want the oven to start. Press the Delay Time pad and rotate the mini knob to program the time of day for the oven to turn on. Press the mini knob to set the start time and then rotate the mini knob to select AM or PM. Press the mini knob to save the time. Set the desired cooking mode and temperature. A cook time may also be programmed if desired. This can only be used with Traditional Bake, Convection Bake 1 Rack, Convection Bake Multi, Convection Roast and Self-Clean.

NOTE: When using the delay time feature, foods that spoil easily—such as milk, eggs, fish, stuffings, poultry and pork— should not be allowed to sit for more than 1 hour before or after cooking. Room temperature promotes the growth of harmful bacteria. Be sure that the oven light is off because heat from the bulb will speed harmful bacteria growth.

10. Probe: Monitors internal food temperature and turns the oven off when the food reaches the programmed temperature. Insert the probe, program the cooking mode, and program the probe temperature. See the Cooking Modes section for more information. The probe can only be used with Traditional Bake, Convection Bake 1 Rack, and Convection Roast.

11. Oven Light(s): Turns the oven light(s) on or off.

12. Remote Enable (on some models):

CONNECTING YOUR OVEN

Off - Oven is not connected. Open the app then select Remote Enable to begin the connecting process.

Slow flash - Oven is in discovery mode and looking for a network.

Rapid flash - An error occurred during the connecting process.

Solid - Oven is connected to the network and can be remotely controlled by a connected mobile device when in operation, but it cannot be started remotely.

REMOTE STARTING YOUR OVEN REMOTE

To be able to start the oven remotely, select Remote Enable and the REMOTE icon will turn on in the display. The oven can now be remotely started with a connected device. Opening an oven door or turning off the oven will turn off the REMOTE icon. The REMOTE icon must be lit to start the

oven remotely. The REMOTE icon is not required to change the oven settings or to turn the oven off. After using the oven, remember to verify that the REMOTE icon is lit if you wish to start the oven remotely in the future.

13. Lock Controls: Locks out the control so that pressing the pads does not activate the controls. Press and hold the Oven Lights and Timer On/Off pads at the same time for three seconds to lock or unlock the control.

Special Features

There are numerous special features that are controlled using the mini knob.

- End tone - Cycle End Tone
- Sound - Tone Volume
- Setting - Clock Setting
- Auto Recipe - Auto Recipe Conversion
- (for Convection Baking)
- 12hr shutoff - 12 Hour Shutoff
- Sabbath - Sabbath mode
- Temp Offset - Adjust the oven temperature
- Display Sleep - Energy saving mode
- Door Alert - Door Open Alert
- Default - Reset control to factory settings

To change the Special Features settings follows these guidelines.

Press and hold the Cook Time and Delay Time pads for 3 seconds simultaneously.

When you enter the special features mode:

- Rotate the mini knob to scroll thru the available features and to change special feature settings.
- Press the mini knob to select the special feature to change. This places the feature into edit mode, allowing the feature to be changed by rotating the mini knob.
- Press the mini knob to enter the selection and to move back up a level.

Press the mini knob to enter the selection and to move back up a level. Press and hold the Cook Time and Delay Time pads for 3 seconds simultaneously to exit the special feature mode. Also, if no selection is made within 30 seconds, the control will automatically exit special features mode.

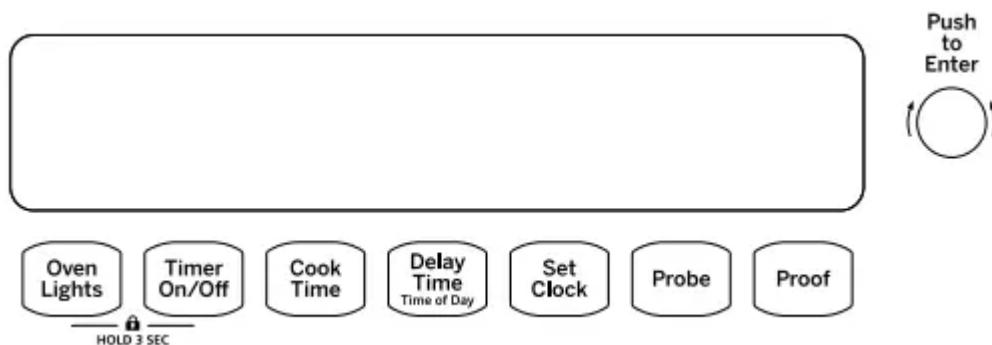

Example: Adjusting the Oven Temperature

1. Press and hold the Cook Time and Delay Time pads for 3 seconds simultaneously to enter special features mode.
3. Press the mini knob to see the current feature setting
4. Turn the mini knob to either increase or decrease the temperature in one degree Fahrenheit increments up to + 35° F or down to -35° F.
5. Press the mini knob to save your desired change and to return to the other features.
6. Press and hold the Cook Time and Delay Time pads for 3 seconds simultaneously to exit the special feature mode.

Cycle End Tone (End tonE)

This is the tone that signals the end of a timer. You can change it to be one tone (bEEP) or a continuous repeating tone (Con).

Tone Volume (Sound)

This feature allows the oven tone volume to be adjusted between Hi, std (default), Lo and oFF.

Clock Setting (SEtting)

This feature specifies how the time of day will be displayed. Options are for a standard 12-hour clock with AM and PM selections (12h), 24-hour military time display (24h), or for no display (OFF).

Auto Recipe Conversion (Auto rEciPE)

When using Convection Bake or Convection Bake Multi cooking modes, Auto Recipe conversion will automatically reduce the programmed cooking mperature. Note that this option does not convert convection baking times, only temperatures.

12-hour Shutoff (12 hr ShutOFF)

When this feature is turned on, the oven will automatically turn off after 12 continuous hours of use.

Adjust the Oven Temperature (UPPEr tE-P oFFSEt)

This feature allows the oven temperature to be adjusted up to 35°F hotter or down to 35°F cooler. Use this feature if you believe your oven temperature is too hot or too cold and wish to change it.

This adjustment affects Traditional Bake, Convection Bake, and Convection Bake Multi Rack modes.

Display Sleep (diSP SLEEP)

This feature turns off the display after 5 minutes of no use when turned on. This feature is designed as an energy saving mode.

Door Open Alert (door ALERt)

This feature alerts the user that a door is not closed all the way. Options include receiving the alert after 30 seconds (30s), 60 seconds (60s), and 90 seconds (90s) after the door was opened. Or the feature may be turned off (OFF).

Default (dEFault)

This feature resets all of the special features to the default settings originally on the oven

Sabbath (SAbbAtH)

Sabbath mode disables the oven lights (the oven light will not turn on when a door is opened), all sounds (the control will not beep when a pad is pressed), Convection modes, Broil modes, Warm, Proof, and all time functions. Sabbath mode can only be used with Traditional Bake. This feature conforms to the Star-K Jewish Sabbath requirements

Enter the Sabbath Mode

Press the Cook Time and Delay Time pads at the same time and hold for three seconds. Use the mini knob to scroll thru the special features options to "SAbbAtH", then press the mini knob to select "SAbbAtH", rotate the mini knob to change the Sabbath feature setting from "OFF" to "on", and press the mini knob to confirm the selection.

Press the Cook Time and Delay Time pads at the same time and hold for three seconds to exit special features mode. The] icon will appear in the display to signify that the unit is in Sabbath Mode. The clock will not be displayed.

Start a Sabbath Bake

Rotate the knobs to select Bake and your desired cooking temperature. At a random time between 30 seconds and 1 minute, the][icon will appear in the display indicating the oven is running.

Adjust the Temperature During a Sabbath Bake

If you need to adjust the temperature, rotate the temperature knob to the new selection. No sound will be given when the keys are pressed. Since no feedback is given during temperature change, an oven thermometer can be used to confirm temperature changes.

Timed Bake During Sabbath

If you wish to use the Cook Time feature to bake in the oven and then have the oven automatically turn off, do not enter Sabbath mode. You will need to change the Cycle End Tone from a continuous beep to a single beep, turn the Tone Volume off, and turn the oven light on using the control panel. Then you can program the desired cook time in bake. Note that Cook Time will immediately start to count down after it is set.

Exit the Sabbath Mode

To end a bake cycle, turn both knobs to off. The] [icon will change to the] icon, indicating that the oven has turned off. Press the Cook Time and Delay Time pads at the same time and hold for three seconds. Use the mini knob to scroll thru the special features options to "SAbbAtH", then press the mini knob to select "SAbbAtH", rotate the mini knob to change the Sabbath feature setting from "on" to "OFF", and press the mini knob to confirm the selection. Press the Cook Time and Delay Time pads for 3 seconds to exit special features mode. The clock will be displayed again indicating the oven is out of Sabbath Mode

French Oven Doors

The French oven doors on this oven are unique. The doors open out to the side of the unit and they open together. Make sure that the area to each side of the oven is clear when opening the oven doors so that the doors can open fully and do not hit any open doors, open drawers, or other items to the side of the oven

Pulling on one handle will make both doors open.

Make sure oven doors are fully closed when cooking. If the doors are open or not shut all the way for more than 60 seconds during a cooking mode, the oven will turn off and the control will ask you to close the doors to resume cooking

CAUTION Make sure that the doors are fully open to prevent burning self.

Pushing on one door will make both doors close. If pushing the doors closed with only one of the handles, please use the left handle. The center door seal requires the right door to close slightly before the left door.

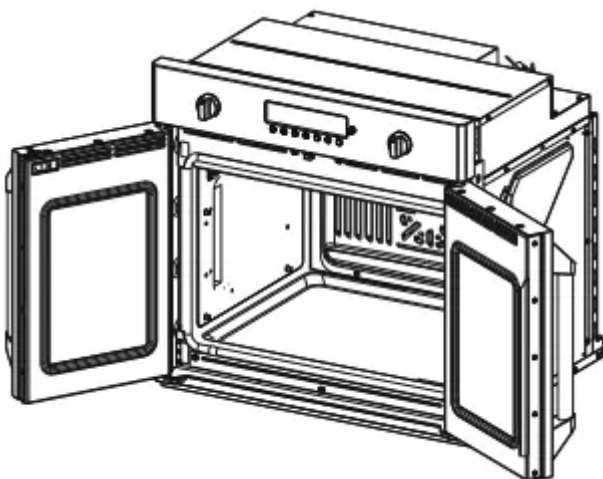

Oven Racks

Your oven has six rack positions. Recommended rack positions for various types of foods are provided in the Cooking Guide. Adjusting rack position is one way to impact cooking results. For example, if you would prefer darker tops on cakes, muffins, or cookies, try moving food one rack position higher. If you find foods are too brown on top try moving them down next time.

When baking with multiple pans and on multiple racks, ensure there is at least 1½" between pans to allow sufficient space for air to flow.

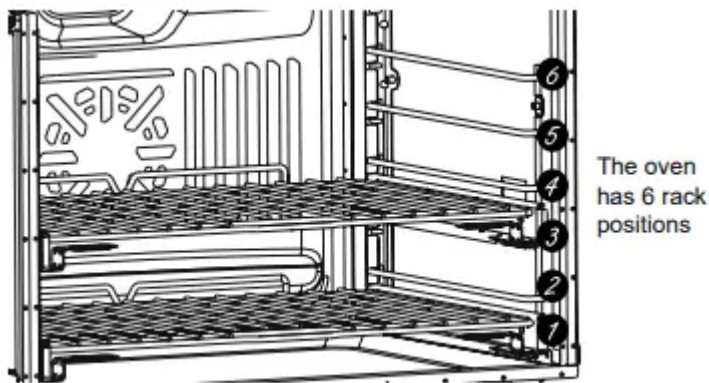

Oven Racks

Your oven may have extension racks and/or traditional flat racks. To avoid possible burns, place the racks in the desired position before you turn the oven on.



Extension Racks

Extension racks have an install feature that locks into the rack supports (guides) on both sides. Once the install feature is locked into place, always pull the rack out, by its upper front rail, to its full extension stop position, when placing or removing cookware.

If extension racks are difficult to extend, lubricate the racks with the graphite lubricant provided with your oven. Remove the rack from the oven, remove debris in the slide tracks with a paper towel, shake the graphite lubricant and place 4 small drops on the two bottom tracks of the left and right sides. Open and close the rack several times to distribute the lubricant.

To order additional graphite lubricant, see the Accessories and Consumer Support sections at the end of this manual.

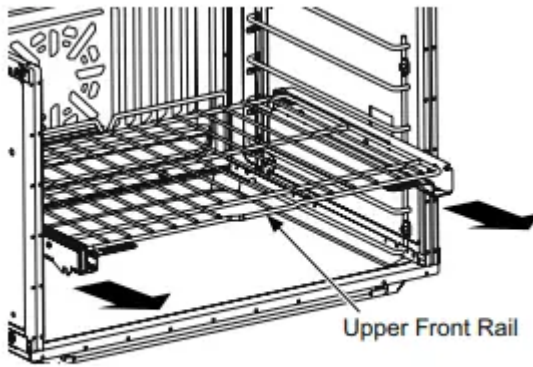

To Remove An Extension Rack

1. Make sure the rack is pushed all the way into the oven.
2. Grasp the rack by both its upper front rail and its lower handles on two sides and lift straight up to unlock the rack from the rack supports.
3. Firmly holding onto both the upper front rail and lower handles on both sides, pull the rack forward. Grasp the rack on both sides if necessary. Then remove it from the oven.

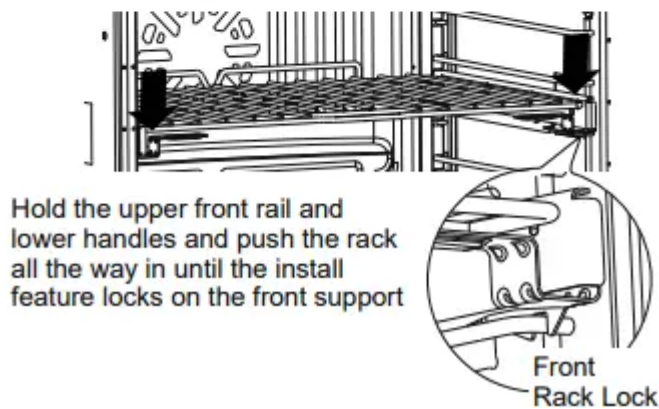
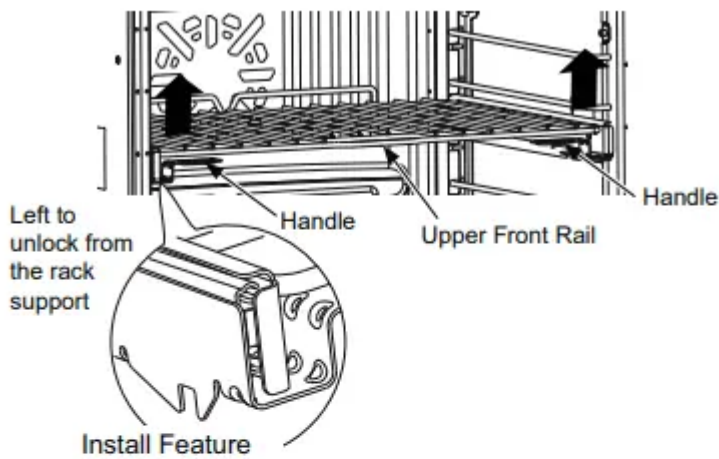

To Replace An Extension Rack

1. Place the rear portion of the rack onto the rack supports (guides) as shown in the picture.



2. Hold the upper front rail and lower handles and push the rack all the way in until the install feature locks into the front rack support.

If extension racks are difficult to replace or remove, wipe the oven rack supports with cooking oil. Do not wipe oil on the rack slides.

Traditional Flat Racks

The racks have stops so that when placed correctly on the supports they will stop before coming completely out and will not tilt. When placing and removing cookware, pull the rack out until it stops.



To Remove a Rack

Pull it toward you, tilt the front end up and pull it out.

To Replace a Rack

Tilt the front of the rack up, hook the rear locating posts under the rack supports, push the rack back (past the stoppers) and lower it into position. Push the rack all the way in.

If flat racks are difficult to slide and/or remove, place some cooking oil on a soft cloth or paper towel and rub onto the sides of the rack and each rack support.

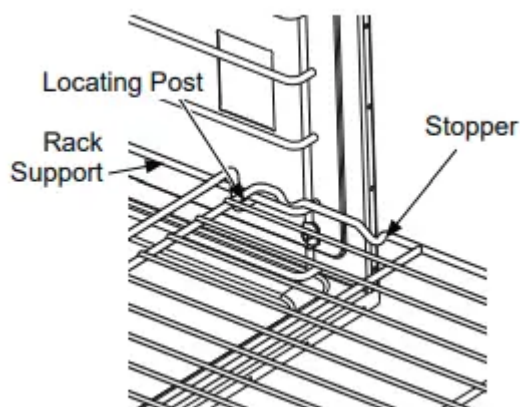

Aluminum Foil and Oven Liners

Foil may be used to catch spills by placing a sheet on a lower rack, several inches below the food. Do not use more foil than necessary and never entirely cover an oven rack with aluminum foil. Keep foil at least 1-1/2" from oven walls to prevent poor heat circulation.

Cooking Modes

Your new oven has a variety of cooking modes to help you get the best results. These modes are described below. Refer to the Cooking Guide section for recommendations for specific foods. Remember, your new oven may perform differently than the oven it is replacing.

Baking and Roasting Modes

Select a mode for baking and roasting based on the type and quantity of food you are preparing. When preparing baked goods such as cakes, cookies, and pastries always preheat the oven first. Follow recipe recommendations for food placement. If no guidelines are provided, center food in the oven.

Traditional Bake

The traditional bake mode is intended for single rack cooking. This mode uses heat primarily from the lower element but also from the upper element to cook food. To use this mode select Bake and then select a temperature. Preheating is generally recommended when using this mode.

Convection Bake with Direct Air

The Convection Bake mode is intended for single rack cooking. This mode uses heat from the lower element and also the upper and rear elements, along with air movement directly down from the top of the oven to enhance evenness. Your oven is equipped with Auto Recipe Conversion, so it is not necessary to convert the temperature when using this mode. To use this mode select Conv Bake 1 Rack and then select a temperature. Preheating is generally recommended when using this mode.

Convection Bake Multi Rack

The Convection Bake Multi Rack mode is intended for baking on multiple racks at the same time. This mode uses heat primarily from the rear element but also heat from the upper and lower elements, along with air movement from the convection fan to enhance cooking evenness. Your oven is equipped with Auto Recipe Conversion, so it is not necessary to convert the temperature when using this mode. Baking time might be slightly longer for multiple racks than what would be expected for a single rack. To use this mode select Conv Bake Multi and then select a temperature. Always preheat when using this mode.

Convection Roast with Direct Air

The Convection Roast mode is intended for roasting whole cuts of meat on a single rack. This mode uses heat from the lower, upper, and rear elements along with air movement directly down from the top of the oven to improve browning and reduce cooking time. It is not necessary to convert temperature. Check food earlier than the recipe suggested time when using this mode, or use the probe. To use this mode select Convection Roast and then select a temperature. It is not necessary to preheat when using this mode.

Broiling Modes

Always broil with the door closed. The broil element in this oven is very powerful. Monitor food closely while broiling. Use caution when broiling on upper rack positions as placing food closer to the broil element increases smoking, spattering, and the possibility of fats igniting. Broiling on rack position 6 is not recommended.

Try broiling foods that you would normally grill. Adjust rack positions to adjust the intensity of the heat to the food. Place foods closer to the broil element when a seared surface and rare interior is desired. Thicker foods and foods that need to be cooked through should be broiled on a rack position farther from the broiler or by using Traditional Broil Lo or Convection Broil Lo. For best performance, center food below the broil heating element.

Traditional Broil Hi

The Traditional Broil Hi mode uses intense heat from the upper element to sear foods. Use Broil Hi for thinner cuts of meat and/or foods you prefer less done on the interior. To use this mode select High/Low Broil and then select High Broil. It is not necessary to preheat when using this mode.

Traditional Broil Lo

The Traditional Broil Lo mode uses less intense heat from the upper element to cook food thoroughly while also producing surface browning. Use Broil Lo for thicker cuts of meat and/or foods that you would like cooked all the way through. To use this mode select High/Low Broil and then select Low Broil.

It is not necessary to preheat when using this mode.

Convection Broil Hi with Direct Air

The Convection Broil Hi mode uses intense heat from the upper element along with air movement directly down from the top of the oven for improved searing and browning. To use this mode select Convection Broil and then select High Broil. For best results preheat 5 minutes when using this mode..

Convection Broil Lo with Direct Air

The Convection Broil Lo mode uses less intense heat from the upper element along with air movement directly down from the top of the oven. To use this mode select Convection Broil and then select Low Broil. For best results preheat 5 minutes when using this mode.

Convection Broil Crisp with Direct Air

The Convection Broil Crisp mode is intended as a finishing mode at the end of a cooking cycle to add surface browning to a dish such as a casserole or a roast. To use this mode select Low Broil Crisp and then select Low Broil. Monitor food closely to prevent over browning.

Proof

Proof mode is designed for rising (fermenting and proofing) bread dough. Turn knob to bake and then press the Proof pad. Cover dough well to prevent drying out. Bread will rise more rapidly than

at room temperature.

Warm

Warm mode is designed to keep hot foods hot for up to 3 hours. To use this mode, select Bake and then select Warm. Cover foods that need to remain moist and do not cover foods that should be crisp. Preheating is not required. Do not use warm to heat cold food other than crisping crackers, chips or dry cereal. It is also recommended that food not be kept warm for more than 2 hours.

Probe

Proper Probe Placement

After preparing the meat and placing it on the cooking pan follow these instructions for proper probe placement.

- Insert the probe into the food, so that the tip of the probe will rest in the center of the thickest part of the food. For best performance the probe should be fully inserted into the food. If the probe is not located properly, it may not accurately measure the temperature of the coolest portion of the food. Some foods, particularly small items, are not well suited for cooking with the probe due to their shape or size.
- The probe should not touch bone, fat or gristle.
- For whole poultry insert the probe into the thickest part of the breast.
- For boneless roasts, insert the probe into the center of the roast.
- For bone-in ham or lamb, insert the probe into the center of the lowest large muscle or joint.
- For casseroles or dishes such as meatloaf, insert the probe into the center of the dish.
- For fish, insert the probe from just above the gill into the meatiest area, parallel to the backbone.

Probe Usage

To use the probe without preheating:

1. Insert the probe into the food (see Proper Probe Placement).
2. Place the food in the oven and connect the probe into the probe outlet in the oven.
3. Program the desired probe and cooking mode settings by pressing the Probe pad and setting the desired internal food temperature by rotating the mini knob and pressing the mini knob to enter the temperature, then set the cook mode (Traditional Bake, Convection Bake, or Convection Roast) and the desired cooking temperature. The maximum internal food temperature that you can set is 200°F.

To use the probe with preheating:

1. Set the desired cook mode (Traditional Bake, Convection Bake, or Convection Roast) and the desired cooking temperature.

2. Insert the probe into the food (see Proper Probe Placement).
3. Once the oven is preheated, place the food in the oven and connect the probe to the probe outlet, making sure it is fully inserted. Use caution, the oven walls and probe outlet are hot.
4. Program the probe temperature by pressing the Probe pad and setting the desired internal food temperature by rotating the mini knob and pressing the mini knob to enter the temperature. The maximum internal food temperature that you can set is 200°F.

Probe Care Guidelines

- Use of probes other than the one provided with this product may result in damage to the probe.
- Use the handles of the probe and plug when inserting and removing them from the meat and outlet
- To avoid damaging your probe, do not use tongs to pull on the cable when removing it.
- To avoid breaking the probe, make sure food is completely defrosted before inserting the probe.
- To prevent possible burns, do not unplug the probe from the outlet until the oven has cooled.
- Never leave the probe inside the oven during a self or steam clean cycle.
- Do not store the probe in the oven.

Cookware

The material, finish, and size of cookware affect baking performance.

Dark, coated and dull pans absorb heat more readily than light, shiny pans. Pans that absorb heat more readily can result in a browner, crisper, and thicker crust. If using dark and coated cookware check food earlier than minimum cook time. If undesirable results are obtained with this type of cookware consider reducing oven temperature by 25° F next time.

Shiny pans can produce more evenly cooked baked goods such as cakes and cookies.

Glass and ceramic pans heat slowly but retain heat well. These types of pans work well for dishes such as pies and custards.

Air insulated pans heat slowly and can reduce bottom browning.

Keep cookware clean to promote even heating.

Care and Cleaning

Oven

Be sure electrical power is off and all surfaces are cool before cleaning any part of the oven.

Control Panel

It's a good idea to wipe the control panel after each use. Clean with mild soap and water or vinegar and water, rinse with clean water and polish dry with a soft cloth.

Do not use abrasive cleansers, strong liquid cleansers, plastic scouring pads or oven cleaners on the control panel—they will damage the finish,

Oven Exterior

Do not use oven cleaners, abrasive cleansers, strong liquid cleansers, steel wool, plastic scouring pads, or cleaning powders on the interior or exterior of the oven. Clean with a mild soap and water or vinegar and water solution. Rinse with clean water and dry with a soft cloth. When cleaning surfaces, make sure that they are at room temperature and not in direct sunlight.

If stain on the door vent trim is persistent, use a mild abrasive cleaner and a sponge-scrubber for best results.

Spillage of marinades, fruit juices, tomato sauces and basting liquids containing acids may cause discoloration and should be wiped up immediately. Let hot surfaces cool, then clean and rinse.

Stainless Steel Surfaces (on some models)

Do not use a steel wool pad; it will scratch the surface.

To clean the stainless steel surface, use warm sudsy water or a stainless steel cleaner or polish. Always wipe the surface in the direction of the grain. Follow the cleaner instructions for cleaning the stainless steel surface. Cleaners with oxalic acid such as Bar Keepers Friend Soft Cleanser FM will remove surface rust, tarnish and small blemishes. Use only a liquid cleanser free of grit and rub in the direction of the brush lines with a damp, soft sponge. To inquire about purchasing cleaning products including stainless steel appliance cleaner or polish read the Accessories sections of this manual.

Oven Interior

The interior of your new oven can be cleaned manually or by using the Steam Clean or Self Clean modes.

Spillage of marinades, fruit juices, tomato sauces and basting liquids containing acids may cause discoloration and should be wiped up immediately. Let hot surfaces cool, then clean and rinse.

Manual Cleaning

Do not use oven cleaners, abrasive cleaners, strong liquid cleansers, steel wool, scouring pads, or cleaning powders on the interior of the oven. Clean with a mild soap and water or vinegar and water solution. Rinse with clean water and dry with a soft cloth. When cleaning surfaces, make sure that they are at room temperature.

Steam Clean Mode

Steam clean is intended to clean small spills using water and a lower cleaning temperature than Self-Clean.

To use the Steam Clean feature, wipe grease and soils from the oven. Pour one cup of water into the bottom of the oven. Close the door. Press the Steam Clean pad and then press Start. The oven door will lock. You can not open the door during the 30 minute steam clean as this will decrease the steam clean performance. At the end of the steam clean cycle the door will unlock. Wipe out any excess water and any remaining soil.

Self Clean Mode

Read Self-Cleaning Oven Safety Instructions at the beginning of this manual before using Self Clean Mode.

Self clean uses very high temperatures to clean the oven interior. The oven door will lock when using this feature. Before operating the self-clean cycle, wipe up grease and soils from the oven. Remove all items from the oven other than enameled (dark color) racks. Shiny or silver racks and any cookware or other items should all be removed from the oven before initiating a self-clean cycle. Close the door. Press the Self Clean pad and a default self-clean time is displayed. The clean time can be changed to any time between 3:00 and 5:00 hours by using the number pads to enter a different time and pressing Start. For heavily soiled ovens, the maximum 5 hour clean time is recommended. If you wish to use the default time, press the Start pad immediately after pressing the Self Clean pad. The oven will turn off automatically when the self-clean cycle is complete. The door will stay locked until the oven has cooled down. After the oven has cooled down wipe any ash out of the oven.

Oven Racks

The racks that were provided with your oven (dark enameled racks, not shiny) may remain in the oven during the self-cleaning cycle without being damaged. To manually clean racks, use warm, soapy water. Make sure not to wash the rack slides on an extension rack.

If racks become more difficult to remove from the oven, put some vegetable oil on a soft cloth or paper towel and rub onto the oven rack supports. Do not wipe the oil on an extension rack slide.

Periodically, after several self-clean cycles, the extension rack slides may need to be lubricated using the graphite lubricant shipped with your wall oven. To order additional graphite lubricant, see the Accessories and Consumer Support sections at the end of this manual

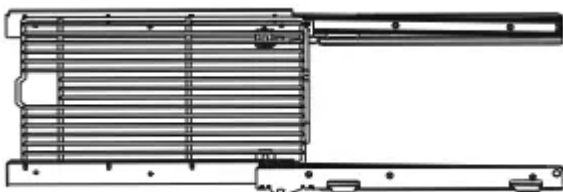

1. Remove extension rack from the oven. See the Extension Oven Racks section.

2. Fully extend the rack on a table or countertop. Newspaper may be placed underneath the rack for easy clean up.

3. If there is debris in the slide tracks, wipe it away using a paper towel. NOTE: Any graphite lubricant wiped away must be replaced.

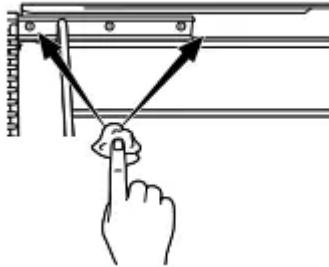

4. Shake the graphite lubricant before opening it. Starting with left slide mechanism of the rack, place four (4) small drops of lubricant on the two (2) bottom tracks of the slide close to the bearing carriers.

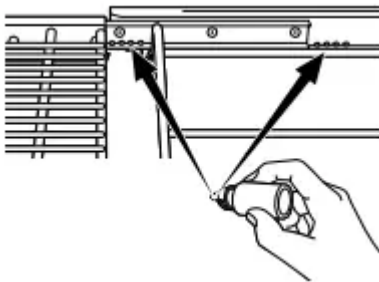

5. Repeat for the right slide mechanism of the rack.

6. Open and close the rack several times to distribute the lubricant.

7. Replace the cap on the lubricant and shake it again. Turn the rack over and repeat steps 3, 4, 5 and 6.

8. Close the rack, turn rack right-side-up and place in the oven. See the Extension Oven Racks section.

9. Repeat above steps for each rack

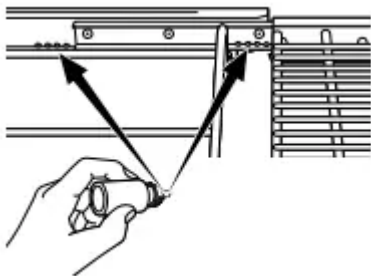

Probe

The temperature probe may be cleaned with soap and water or a soap-filled scouring pad. Cool the temperature probe before cleaning. Scour stubborn spots with a soap-filled scouring pad, rinse and dry. To order additional temperature probes, see the Accessories and Consumer Support sections at the end of this manual.

- Do not immerse the temperature probe in water.
- Do not store the temperature probe in the oven.
- Do not leave the temperature probe inside the oven during a self or steam clean cycle.



Oven Light

Oven Light Replacement

The French oven doors are not removable or consumer serviceable.

Oven Doors

Oven Door Center Seals

If you notice discoloring of the two door center seals that cannot be removed with warm sudsy water and a soft cloth, use a stainless steel cleaner that removes heat discoloration and/or tarnishing.

Do not use abrasive cleaners, metal scouring pads, commercial oven cleaners or sharp objects to try and clean the center seals since this can damage these door parts.

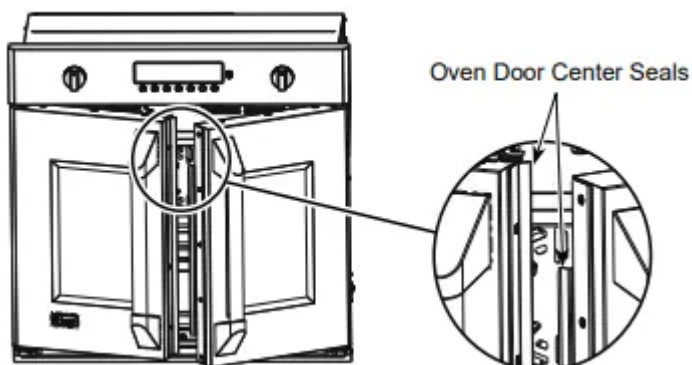

Oven Doors

The oven doors are not removable or consumer serviceable

Troubleshooting tips

Save time and money! Review the charts on the following pages first and you may not need to schedule service.





| Problem | Possible Cause | What To Do |
|--|--|---|
| My new oven doesn't cook like my old one. Is something wrong with the temperature settings? | Your new oven has a different cooking system from your old oven and therefore may cook differently than your old oven. | For the first few uses, follow your recipe times and temperatures carefully. If you still think your new oven is too hot or too cold, you can adjust the temperature yourself to meet your specific cooking preference. See the Special Features Section to adjust the oven temperature |
| Food does not bake properly | Oven controls improperly set | See the Cooking Modes section. |
| | Rack position is incorrect or rack is not level. | See the Cooking Modes section and Cooking Guide. |
| | Incorrect cookware or cookware of improper size being used | See the Cookware section |
| | Oven temperature needs adjustment | See the Special Features section |
| | Ingredient substitution | Substituting ingredients can change the recipe outcome. |
| Food does not broil properly | Oven controls improperly set. | Make sure you select the appropriate broil mode. NOTE: Convection crisp is not for broiling foods. |
| | Improper rack position being used. | See the Cooking Guide for rack location suggestions. |
| | Food being cooked in a hot pan | Make sure cookware is cool |
| | Cookware not suited for broiling | Use a pan specifically designed for broiling |
| | Aluminum foil used on the broiling pan and grid has not been fitted properly and slit as recommended. | If fusing aluminum foil conform to pan slits. |



| | | |
|--|---|---|
| | In some areas the power (voltage) may be low | Preheat the broil element for 10 minutes |
| Oven temperature too hot or too cold | Oven temperature needs adjustment | See the Special Features section. |
| Oven does not work or appears not to work | A fuse in your home may be blown or the circuit breaker tripped. | Replace the fuse or reset the |
| | Oven controls improperly set. | See the Using the Oven section. |
| | Oven is in Sabbath Mode. | Verify, that the oven is not in Sabbath Mode. See the Special Features section. |
| “Crackling” or “popping” sound | This is the sound of the metal heating and cooling during both the cooking and cleaning functions. | This is normal. |
| Why is my range making a “clicking” noise when using my oven? | Your range has been designed to maintain a tighter control over your oven's temperature. You may hear your oven's heating elements “click” on and off more frequently than in older ovens to achieve better results during baking, broiling, and self-clean cycles. | This is normal |
| Clock and timer do not work | A fuse in your home may be blown or the circuit breaker tripped | Replace the fuse or reset the circuit breaker. |
| | | |

| | | |
|---|---|---|
| Sometimes the oven takes longer to preheat to the same temperature | Cookware or food in oven | The cookware or food in the oven will cause the oven to take longer to preheat. Remove items to reduce preheat time. |
| | Number of racks in oven | Adding more racks to the oven will cause the oven to take longer to preheat. Remove some racks |
| Oven light does not work | Light bulb is loose or defective. | Tighten or replace bulb. |
| | Pad operating light is broken. | Call for service. |
| Oven will not self-clean | The temperature is too high to set a self-clean operation | Allow the oven to cool and reset the controls. |
| | Oven controls improperly set | See the Cleaning the Oven section. |
| Excessive smoking during clean cycle | Excessive soil or grease. | Turn both knobs to OFF. Open the windows to rid the room of smoke. Wait until the LOCKED light goes off. Wipe up the excess soil and reset the clean cycle. |
| Excessive smoking during broiling | Food too close to burner element. | Lower the rack position of the food. |
| Oven door will not open after a clean cycle | Oven too hot. | Allow the oven to cool below locking temperature. |
| Oven not clean after a clean cycle | Oven controls improperly set | See the Cleaning the Oven section. |
| | Oven was heavily soiled. | Clean up heavy spillovers before starting the clean cycle. Heavily soiled ovens may need to self-clean again or for a longer period of time. |
| | | Close the oven door. Wait for oven door to finish locking. |

| | | |
|--|--|--|
| "DOOR " flashes in the display | The self-clean cycle has been selected but the door is not closed. | |
| | "DOOR  " will flash while the oven door is locking to start self-clean and steam clean. | This is normal. |
| "DOOR  " light is on when you want to cook | The oven door is locked because the temperature inside the oven has not dropped below the locking temperature. | Allow the oven to cool |
| "F— and a number or letter" flash in the display | You have a function error code | Press the mini knob. Allow the oven to cool for one hour. Put the oven back into operation. |
| | If the function code repeats. | Disconnect all power to the oven for at least 30 seconds and then reconnect power. If the function error code repeats, call for service |
| Display goes blank | A fuse in your home may be blown or the circuit breaker tripped. | Replace the fuse or reset the circuit breaker |
| | The clock is turned off or display sleep is turned on. | See the Special Features section |
| | Oven is in Sabbath Mode. | Verify that the oven is not in Sabbath Mode. See the Special Features section. |
| Power outage, clock flashes | Power outage or surge | Reset the clock. If the oven was in use, you must reset it by pressing the Cancel/Off pad, setting the clock and resetting any cooking function. |

| | | |
|---|--|--|
| <p>“Burning” or “oily” odor emitting from the vent</p> | <p>This is normal in a new oven and will disappear in time.</p> | <p>To speed the process, set a self-clean cycle for a minimum of 3 hours. See the Cleaning the Oven section. This is temporary</p> |
| <p>Strong odor</p> | <p>An odor from the insulation around the inside of the oven is normal for the first few times the oven is used.</p> | <p>This is temporary and will go away after several uses or a self-clean cycle.</p> |
| <p>Fan noise</p> | <p>A cooling fan may automatically turn on.</p> | <p>This is normal. The cooling fan will turn on to cool internal parts. It may run for up to 1-1/2 hours after the oven is turned off.</p> |
| <p>My oven door glass appears to be "tinted" or have a "rainbow" color. Is this defective?</p> | <p>No. The inner oven glass is coated with a heat barrier to reflect the heat back into the oven to prevent heat loss and keep the outer door cool while baking.</p> | <p>This is normal. Under certain light or angles, you may see this tint or rainbow color.</p> |
| <p>Sometimes the oven takes longer to preheat to the same temperature</p> | <p>Cookware or food in oven</p> | <p>The cookware or food in the oven will cause the oven to take longer to preheat. Remove items to reduce preheat time.</p> |
| | <p>Number of racks in oven</p> | <p>Adding more racks to the oven will cause the oven to take longer to preheat. Remove some racks</p> |
| | <p>Different cooking modes</p> | <p>The different cooking modes use different preheat methods to heat the oven for the specific cooking mode. Some modes will take longer than others (i.e. convection bake multi).</p> |
| <p>Oven will not work remotely</p> | <p>Router issues, no wireless signal, etc</p> | |



Oven is not connected.

For assistance with oven wireless network connectivity, visit cafeappliances.com/connect

Accessories

Looking For Something More?

CAFÉ offers a variety of accessories to improve your cooking and maintenance experiences!

Refer to the Consumer Support page for phone numbers and website information.

The following products and more are available:

Accessories

XL Broiler Pan (17 " x 1 1/4" x 19 1/4")

Parts

Oven racks

Oven elements

Probe

Cleaning Supplies

CitruShine™ Stainless Steel Wipes

CeramaBryte Stainless Steel Appliance Cleaner

Graphite Lubricant

Warning

This content is compiled from multiple sources and is provided for reference purposes only. It may not be complete or fully applicable to all situations. If you are unable to resolve your issue, please contact the product manufacturer or an authorized service provider for official support.