

PART NAMES

Microwave features

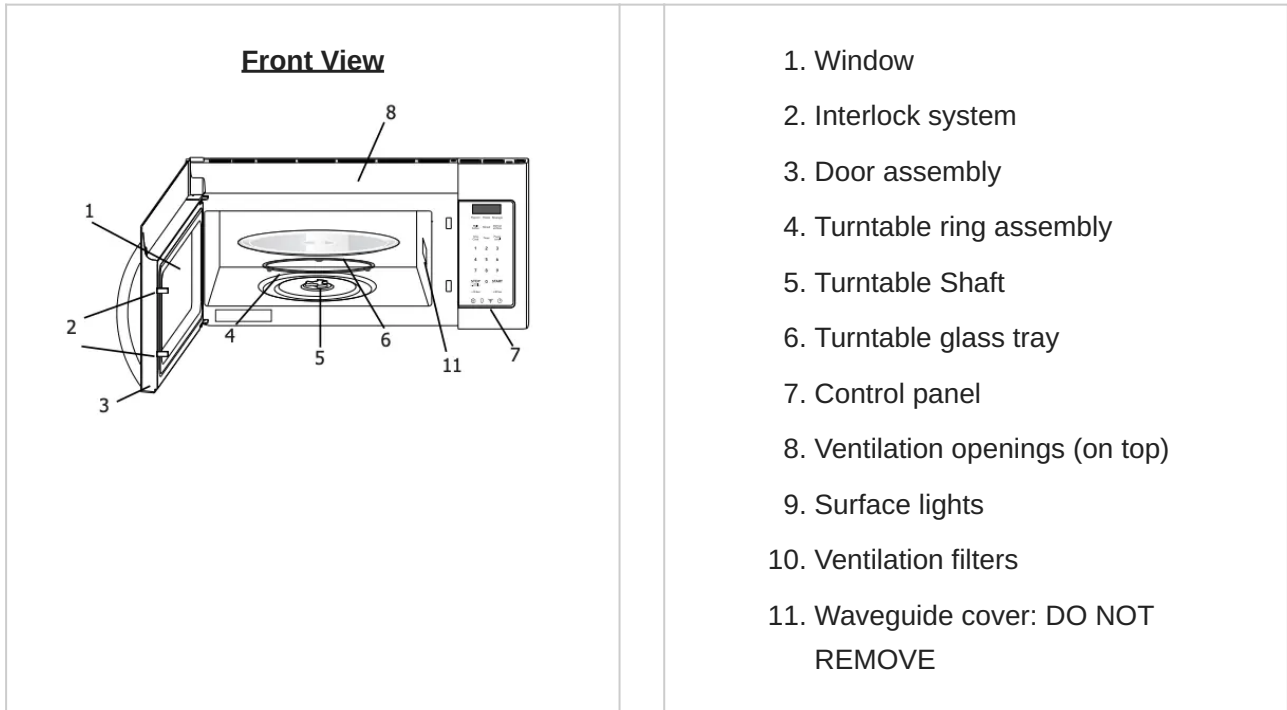

Bottom View

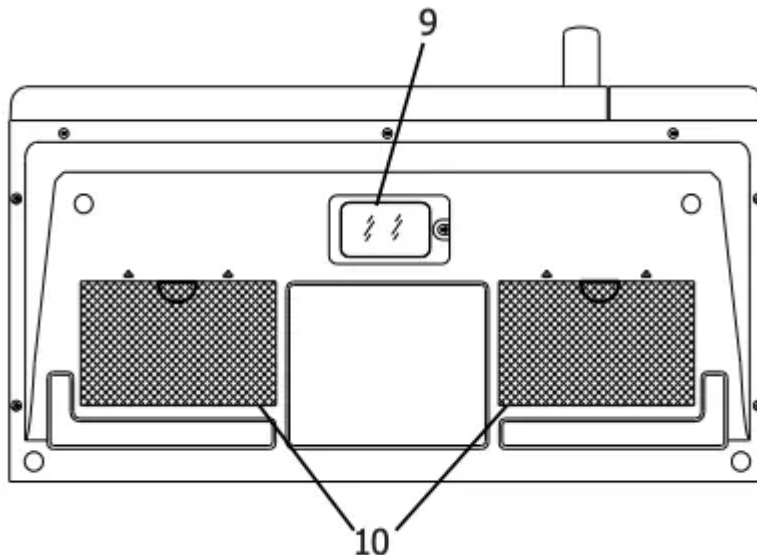

CONTROL PANEL

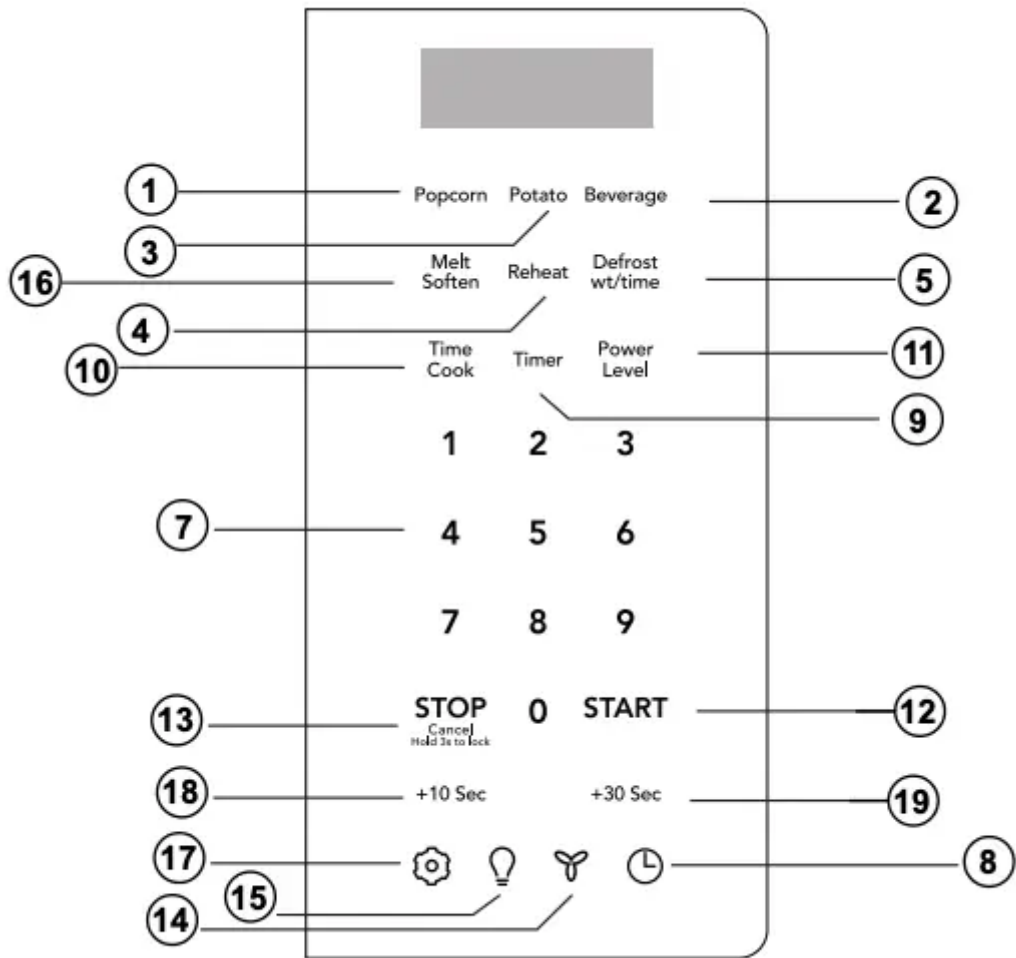

<ol style="list-style-type: none"> 1. Popcorn (P17) 2. Beverage (P17) 3. Potato (1-4 potatoes) (P17) 4. Reheat (3 different settings) (P15) 5. Defrost (by time or weight) (P13) 6. Quick Start (3 instant key settings) (P11) 7. Numeric pads (0 thru 9) 8. Clock 9. Timer 10. Time Cook 11. Power Level (10 power levels available) (P16) 	<ol style="list-style-type: none"> 12. START +30 sec 13. Stop/Cancel (P12) 14. Exhaust (High/Low/Off) ~ Use to turn the exhaust fan on, off, or to adjust fan speed. (P10) 15. Surface Light ~ Press this pad to turn the surface lights on or off 16. Melt Soften 17. Setting 18. +10 Sec 19. +30 Sec
---	--





Note:For detailed information,please go to relative page listed above.

BEFORE OPERATING

Settings

The microwave oven has settings that allow you to customize the operation for your convenience.

Below is the table showing the various settings .Touch the  key multiple times to scroll to the desired setting function.

Key press	Option
 x1	Sound Low/nor/Hi/Off(nor=Normal)
 x2	Weight lb/kg
 x3	Clock Disply On/Off
 x4	Demo



Setting the clock

Example: setting clock display for 9:00:

1. Touch  pad once .	
2. Enter time using number pads.	9 0 0
3. Touch pad again.	START

Setting the timer

Example: setting timer for 5 minutes:

1. Touch Timer pad once.	Timer
2. Enter desired time using number pads.	5 0 0
3. Touch Timer pad.	Timer

Timer count down does not stop even if the door is opened. To stop/cancel the timer, press the Timer key once. When the timer has reached the end of set time, you will hear beep alerts indicating the timer has run out.

Exhaust High / Low / Off

The exhaust ventilation removes steam and other cooking vapors from the cooking surface of the range below the microwave oven.

To operate the exhaust vent, Touch the Exhaust High/Low/Off pad once for the highest speed setting. Touch the pad again to choose the Low speed setting and a 3rd time to turn the exhaust ventilation off.		
---	--	--

Note: If the temperature gets too hot around the microwave oven, the fan in the exhaust vent hood will automatically turn on at the LOW setting to cool the oven. The fan will automatically turn off when the internal parts are cool. When this occurs, the vent cannot be turned off.

Surface Light / On / Off

Touch the Surface Light/On/Off pad once for a cooking surface light. Press the pad again to turn the light off.

Control Lock

You may lock the control panel to prevent the microwave from being accidentally started or used by children.

The control lock feature is very useful when cleaning the control panel. The lock will prevent accidental programming when wiping the control panel clean.

Example: to set the control lock ON:

Touch and hold the Stop/Cancel pad for more than 3 seconds. The Lock icon will appear in the display window along with 2 beeps.

Example: to change the control lock from ON to OFF:

Touch and hold the Stop/Cancel pad for more than 3 seconds. The Lock icon will disappear in the display window.

MANUAL COOKING

Using Ready Set

1 2 3

Microwave heating or cooking may be quickly set at 100% power level for 1, 2 or 3 minutes. Use the number keys 1, 2 or 3 to choose the desired minutes of cook time (this option will only work using the 1, 2 or 3 numeric pads):

Example: to quickly heat for 2 minutes at 100% power:

Touch number pads 1, 2 or 3 for desired minutes of cook time. **2**

Note: the Ready Set function cannot be set when using the Defrost (by weight) feature.

NOTE "Food" will be displayed if a quick start cooking cycle is not selected within 5 minutes of placing food in the microwave. You must open then close the door again to clear "Food" from the display.

Heating with high power level

Example: to heat for 5 minutes at 100% power:

1. Press TimeCook pad.	
2. Use the number pads to enter desired heating time (cook time may be set up to 99 minutes and 99 seconds).	
3. Touch pad	

When heating has finished you will hear beeps and "End" will display.

Heating with lower power levels

Using the highest power level to heat foods with does not always give the best results when some types of food need slower cooking, such as roasts, baked goods or custards. Your oven has nine other power levels you may choose.

Example: to heat for 4 minutes at 70% power:

1. Press TimeCook	
2. Use the number pads to enter desired heating time (cook time may be set up to 99 minutes and 99 seconds).	
3. Press Power Level pad once for power level 10 (100% power).	
4. Use the number key to change the power level to 7. P-70 appears in the display (70 % power).	
5. Press Start pad.	

When heating has finished you will hear beeps and "End" will display.

Heating with multiple cooking stages

For best results, some microwave recipes call for different power levels or different lengths of time for cooking. Your microwave may be set to change from one stage to another automatically (2 stages maximum).

Example: to cook food for 3 minutes at 80% power and then 50% power for 6 minutes 30 seconds:



1. Press TimeCook		Time Cook
2. Use the number pads to enter heating time for the 1st stage (cook time may be set up to 99 minutes and 99 seconds).		3 0 0
3. Press Power Level pad once.		Power Level
4. Use the number keys to enter power level for the 1st stage. P-80 in the display (80 % power).		8
5. Press pad for 2nd stage.		Time Cook
6. Use the number pads to enter heating time for the 2nd stage (cook time may be set up to 99 minutes and 99 seconds).		6 3 0
7. Press Power Level pad for 2nd stage		Power Level
8. Use the number key to enter power level for the 2nd stage. P-50 appears in the display (50 % power).		5
9. Press START pad.		START

When heating has finished you will hear beeps and End" will display.

Note: Power level must always be programmed for first stage.

Using the Stop/Cancel key

This feature will let you quickly stop or cancel the cooking process.



Touch the Stop/Cancel pad to :

1. Erase if you have entered wrong information.
2. Cancel timer setting process.

3. Press pad once to pause the oven temporarily during cooking. (Touch START pad again to resume cooking.)

START

4. Return the time of day (clock) to the display after cooking cycle is completed.

5. Cancel a program during cooking, touch twice.

Using the +10 sec /+ 30 sec key

This feature will let you quickly start or add 10 or 30 seconds

+10 Sec / +30 Sec

Touch the +10 sec /+ 30 sec pad to :

1. Start programmed cooking.
2. Start cooking for 10 seconds/30 seconds at 100% power level.
3. Extend cooking time in multiples of 10 seconds/30 seconds each time this pad is touched during microwave cooking.

Example: to add 1 minute of cook time during 80% microwave cooking :

+30 Sec

Press +30 sec pad twice.

Setting Defrost (by Weight)

Example: to defrost 1lb. of food with the default power level and cook time determined automatically:

1. Press Defrost pad once. 0.0 will appear in the display.	
2. Use the numeric pads to input weight of food to defrost in pounds (10 = 1.0lb.) You may enter any weight from 0.1 to 6.0lbs.	
3. Press START pad.	

When defrosting has finished you will hear beeps and "End" will display.

Note: The weight amount must be a valid entry for this feature to start. A valid weight entry is 0.1 to 6.0 pounds.

Setting Defrost (by Time)

Example: to defrost food with the default 30% power level for 5 minutes:

1. Press Defrost pad twice. 0:00 will appear in the display.		
2. Use the number pads to enter desired defrost time (defrost time may be set up to 99 minutes and 99 seconds).		
3. Press START pad.		

When heating has finished you will hear beeps and "End" will display.

Note: Power levels cannot be changed for both defrost (by weight) or defrost (by time) because the defrost performance will be adversely affected.

Special notes for defrosting by time

- After pressing START key, the display will count down remaining defrost time. The oven will beep during the defrost cycle. At this time open the door and turn the food if needed and remove any portions that have already thawed. Touch the START key to resume the defrost cycle.
- When heating has finished you will hear beeps.

Defrosting tips

- When using the defrost weight feature, the weight entered should always be pounds (valid entries are from 0.1 to 6.0 pounds).
- Use both defrost weight and defrost time features for raw food items only. Defrosting gives best results when food to be thawed is a minimum of 0°F (taken directly from a true freezer). If the food has been stored in a refrigerator-freezer that does not maintain a temperature of 5° F or below, always program a lower food weight or lower cook time to prevent cooking the food.
- If the frozen food is stored outside the freezer for up to 20 minutes, enter a reduced cook time or weight.
- The shape of the package will alter the defrosting time. Shallow rectangular food packets defrost more quickly than a deep frozen block of food.
- Separate pieces as they begin to defrost. Separated frozen pieces of food defrost better.
- Shield warm areas of food with small pieces of foil if they start to become warm.
- You may use small pieces of aluminum foil to shield food items like chicken wings, leg tips and fish tails, but do not allow the foil to touch the oven cavity walls when defrosting.

Defrosting suggestions for meats

For best results, please read these suggestions when defrosting meats.



Meat	Normal amount	Suggestions
• Roast beef or pork	2.5 to 6 lbs. (40 to 96 oz.)	Start with the food placed fat side down. After each stage, turn the food over and shield any warm portions with narrow strips of aluminum foil. Let stand, covered for 15-30 minutes.
• Steaks, chops or fish	0.5 to 3 lbs. (8 to 48 oz.)	After each stage, rearrange the food. If there are any warm or thawed portions of food, shield them with narrow flat pieces of aluminum foil. Remove any pieces of food that are nearly defrosted. Let stand, covered for about 5 to 10 minutes.
• Ground meat	0.5 to 3 lbs. (8 to 48 oz.)	After each stage, remove any pieces of food that are nearly defrosted. Let stand, covered with foil for 5 to 10 minutes.
• Whole chicken	2.5 to 6 lbs(40 to 96 oz.)	Remove giblets before freezing poultry. Start defrosting with the breast side down. After the 1st stage, turn the chicken over and shield any warm portions with narrow strips of aluminum foil. After the 2nd stage, again shield any warm portions with narrow strips of aluminum foil. Let stand, covered, for 30 to 60 minutes in the refrigerator.
• Chicken pieces	0.5 to 3 lbs. (8 to 48 oz.)	After each stage, rearrange or remove any pieces of food that are nearly defrosted. Let stand for 10-20 minutes.

Reheat

The reheat feature provides 3 quick preset settings based on serving size to reheat food for your cooking convenience.

Example: to reheat 24 ounces of food

1. Press Reheat pad 3 times (see reheat category table) to reheat 24oz. of food. 24oz will appear in the display	
2. Press START pad.	

Reheat Category	Press	Display
8 ounces of food	once	8 oz
16 ounces of food	twice	16 oz
24 ounces of food	3 times	24 oz

Melt/ Soften

The oven uses low power to melt and soften items. See the following table.

PRESS	DISPLAY	CATEGORY	AMOUNT	KEY
Melt Soften x 1	So-1	BUTTER	1 stick 2 sticks	1 2
Melt Soften x 2	So-2	CHOCOLATE	2 oz. 4 oz. 8 oz.	1 2 3
Melt Soften x 3	So-3	ICE CREAM	1 Pint 1.5 Quart	1 2
Melt Soften x 4	So-4	CREAM CHEESE	3 oz. 8 oz.	1 2

Example: to melt 8 oz of Cream Cheese.

1. Press Melt/Soften pad 4 times to reheat 8oz. of food. So-4 will appear in the display (see Melt/Soften category table). Then press 2 number pad, cook time will appear in the display .	
2. Press START pad.	

Suggested power levels for cooking

The 10 power levels available with this microwave will help you to adjust to the power output best suited for the food type you are preparing. As with any food preparation in the microwave, it is best to follow the microwave instructions that are printed on food packaging.

The table below provides suggested power levels for various types of food that you can be prepare in the microwave.

Power level	Microwave output	Use to prepare when:
10 High	100 %	<ul style="list-style-type: none"> • Boiling water. • Cooking ground beef. • Making candy. • Cooking fresh fruits & vegetables • Cooking fish & poultry. • Preheating browning dish. • Reheating beverages. • Cooking bacon slices.
9	90 %	<ul style="list-style-type: none"> • Reheating meat slices quickly. • Saute onions, celery & green peppers.
8	80 %	<ul style="list-style-type: none"> • All reheating. • Cooking scrambled eggs.
7	70 %	<ul style="list-style-type: none"> • Cooking breads & cereal products. • Cooking cheese dishes & veal. • Cakes, muffins, brownies & cupcakes.
6	60 %	<ul style="list-style-type: none"> • Cooking pasta.
5	50 %	<ul style="list-style-type: none"> • Cooking meats & whole poultry. • Cooking custard. • Cooking spare ribs, rib roast & sirloin roast.
4	40 %	<ul style="list-style-type: none"> • Cooking less tender cuts of meat. • Reheating frozen packaged foods.
3	30 %	<ul style="list-style-type: none"> • Thawing meat, poultry & seafood. • Cooking small quantities of food. • Finish cooking casseroles, stew & some sauces.

2	20 %	<ul style="list-style-type: none"> • Softening butter & cream cheese. • Heating small amounts of food.
1	10 %	<ul style="list-style-type: none"> • Softening ice cream. • Raise yeast dough.

Suggestions for getting the best results

Suggestions for getting the best results

- **Storage temperature**

Foods taken from the freezer or refrigerator take longer to cook than the same foods would at room temperature.

- **Size**

Small pieces of food cook faster than large ones. Pieces similar in size and shape will cook more evenly when cooked together. For more even results, reduce the power levels when cooking large pieces of food.

- **Natural moisture**

Very moist foods cook more evenly because microwave energy heats water molecules very efficiently.

- **Stirring**

Stir foods such as casseroles and vegetable from the outside to the center to distribute the heat more evenly. This will allow the food to cook faster. Constant stirring is not necessary.

- **Turn over items**

Turn over foods such as pork chops, roasts or whole cauliflower halfway through the cook time. This will help to expose all sides equally to microwave energy.

- **Food placement**

Place delicate areas of food items, such as asparagus tips, toward the center of the turntable tray.

- **Food arrangement**

Arrange unevenly shaped foods, such as chicken pieces or salmon, with the thicker or meatier parts toward the outside of the turntable tray.

- **Let the food stand**

After removing the food from the microwave, cover the food with foil or a casserole lid and let it stand to finish cooking. This will help the food finish in the center and avoids overcooking the out edges, The length of stand time depends on the density and surface area of the food items.

- **Wrapping in paper towels or waxed paper**

Sandwiches and many other food types containing prebaked bread should be wrapped prior to placing in the microwave to help prevent the food items from drying out while heating.

CLEANING AND CARE

Disconnect the power cord or leave the door open to deactivate the oven during cleaning. Disconnect the power cord before replacing filters and lights.

EXTERIOR

The outside surface is precoated steel and plastic. Clean the outside with mild soap and water; rinse and dry with a soft cloth. Do not use any type of household or abrasive cleaner.

DOOR

Wipe the window on both sides with a soft cloth to remove any spills or spatters. Metal parts will be easier to maintain if wiped frequently with a soft cloth. Avoid the use of spray and other harsh cleaners as they may stain, streak or dull the door surface.

EASY CARE™ STAINLESS STEEL / SMUDGE PROOF™ STAINLESS _ STEEL / BLACK STAINLESS STEEL (SOME MODELS)

Your microwave oven(some models) may have a Stainless Steel finish or coating. Clean the stainless with warm soapy water using a clean sponge or cloth. Rinse with clean water and dry with a soft clean cloth. DO NOT use ANY store bought cleaners like Stainless Steel cleaners or any other types of cleaners containing any abrasive, chlorides, chlorines or ammonia. It is recommended to use mild dish soap and water or a 50/50 solution of water and vinegar.

TOUCH CONTROL PANEL

Care should be taken in cleaning the touch control panel. If the control panel becomes soiled, open the microwave oven door before cleaning. Wipe the panel with a cloth dampened slightly with water only. Dry with a soft cloth. Do not scrub or use any sort of chemical cleaners. Close door and touch STOP/CLEAR

INTERIOR

Cleaning is easy because little heat is generated to the interior surfaces. To clean the interior surfaces, wipe with a soft cloth and warm water. DO NOT USE ABRASIVE OR HARSH CLEANERS OR SCOURING PADS. For heavier soil, use baking soda or a mild soap; rinse

thoroughly with hot water. The round wire rack and shelf can be cleaned with hot soapy water, rinsed and dried.

WAVEGUIDE COVER

The waveguide cover is located on the right side in the microwave oven cavity. It is made from mica so requires special care. Keep the waveguide cover clean to assure good microwave oven performance. Carefully wipe with a damp cloth any food spatters from the surface of the cover immediately after they occur. Built-up splashes may overheat and cause smoke or possibly catch fire. **DO NOT REMOVE THE WAVEGUIDE COVER.**

ODOR REMOVAL

Occasionally, a cooking odor may remain in the microwave oven. To remove, combine 1 cup water, grated peel and juice of 1 lemon in a 2-cup glass measuring cup. Boil for several minutes using 100% power. Allow to set in microwave oven until cool. Wipe interior with a soft cloth.

TURNTABLE/TURNTABLE SUPPORT

TURNTABLE/TURNTABLE SUPPORT The turntable and turntable support can be removed for easy cleaning. Wash them in mild, sudsy water; for stubborn stains use a mild cleanser and non-abrasive scouring sponge. They are also dishwasher-proof. Use upper wirerack of dishwasher. The turntable motor shaft is not sealed, so excess water or spills should be wiped up immediately

Cleaning the exhaust filters

The oven ventilation exhaust filters should be removed and cleaned often; generally at least once every month.

Vent exhaust filter part number 5304478913

To order parts call 800-599-7569

CAUTION : To avoid risk of personal injury or property damage, do not operate oven hood without filters properly in place.

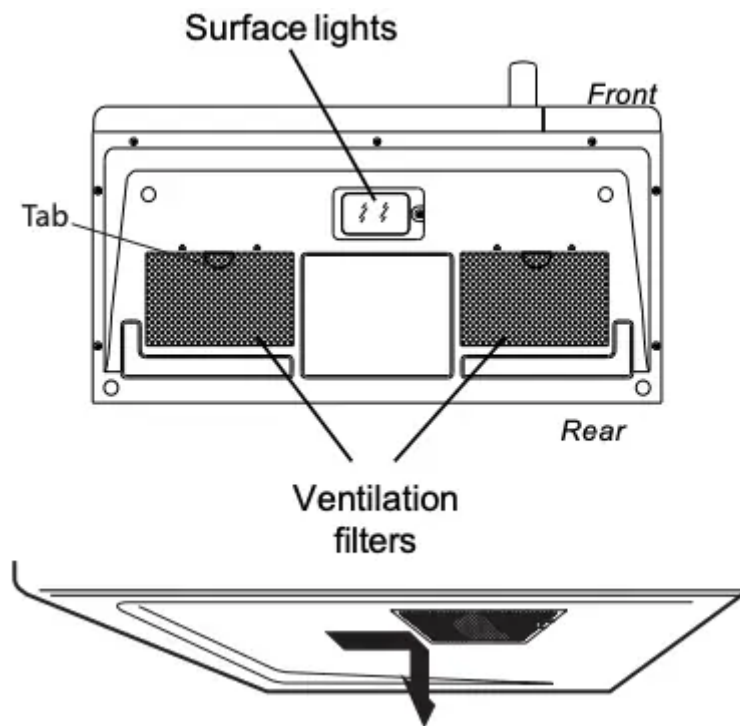

1. To remove the exhaust ventilation filters, slide the filter to the rear. Then pull filter downward and push to the other side. The filter will drop out. Repeat for the 2nd filter.

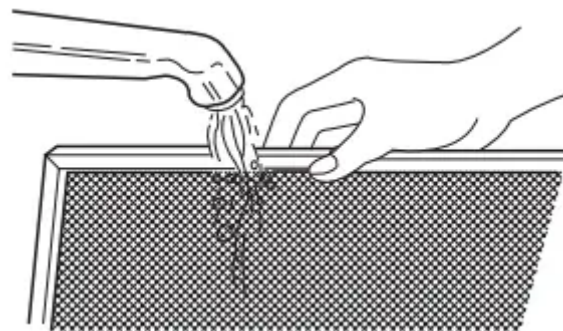

2. Soak the ventilation filters in hot water using a mild detergent. Rinse well and shake to dry or wash in. Do not use ammonia. The aluminum on the filter will corrode and darken.



3. To reinstall the exhaust ventilation filter, slide it into the side slot, then push up and toward oven to lock. Reinstall the 2nd filter using the same procedure.

Surface light replacement

CAUTION To avoid risk of personal injury or property damage, wear gloves when replacing the light bulbs.

1. Unplug the microwave oven or turn off power at the main circuit breaker.
2. Remove the cover mounting screw under the microwave.

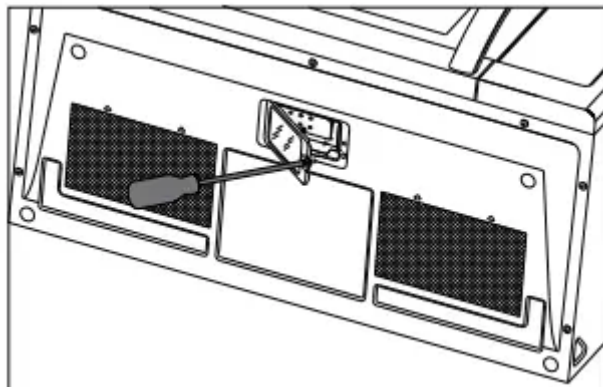

3. Remove the LED light mounting screw.

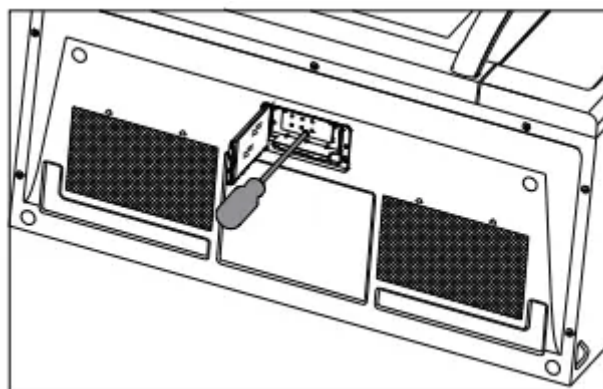

4. Unplug the LED light from the harness, replace with part 5304499540. To order parts call 800-599-7569. Then reconnect the harness.

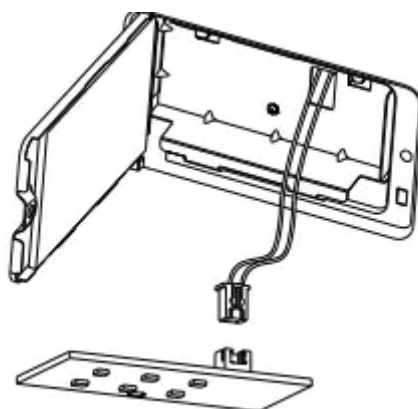

5. Re-install LED light and mounting screw. When re-installing mounting screw be careful not to damage the LED light.
6. Re-install LED light cover and mounting screw.
7. Plug the microwave back into the power supply or turn the power back on at the main circuit breaker.

Charcoal filter replacement

Charcoal filter part number 5304464577

To order parts call 800-599-7569

Charcoal Filter when installed in your microwave oven, is used for nonvented, recirculated Installation. The filter should be changed every 6 to 12 months depending on use.

1. Disconnect power to the microwave oven at the circuit breaker panel or by unplugging.
2. Remove the vent grill mounting screws.
3. Pull the vent grill away from the unit.

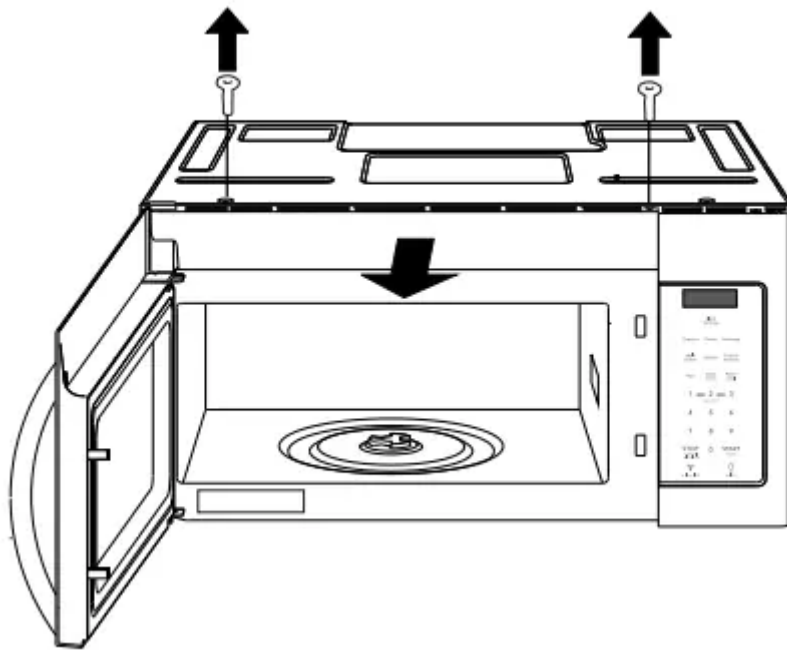

4. Remove the charcoal filter by pushing the top of the filter inwards, then pull it forward out from the unit.

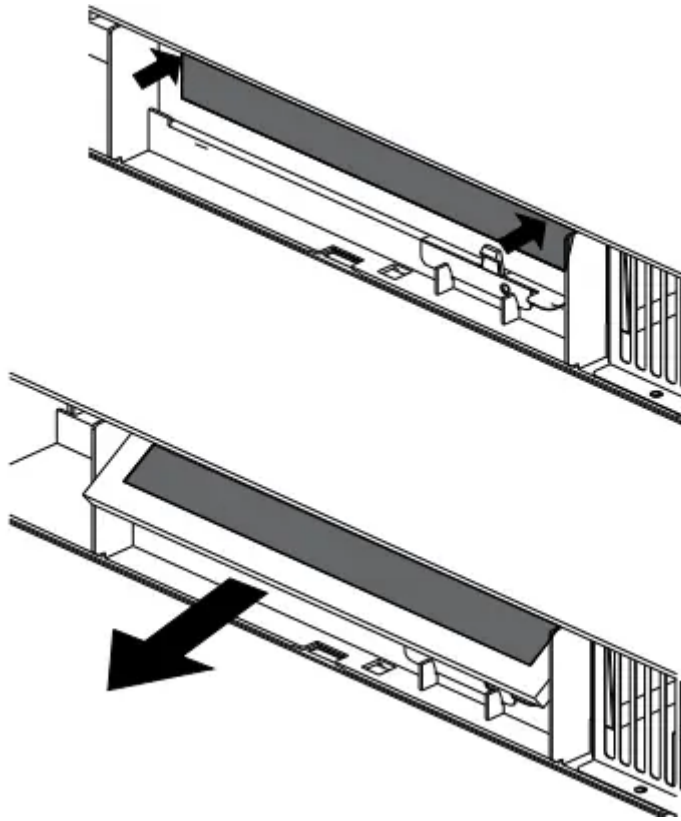

5. Slide the top of the new charcoal filter into the top area of the filter cavity.

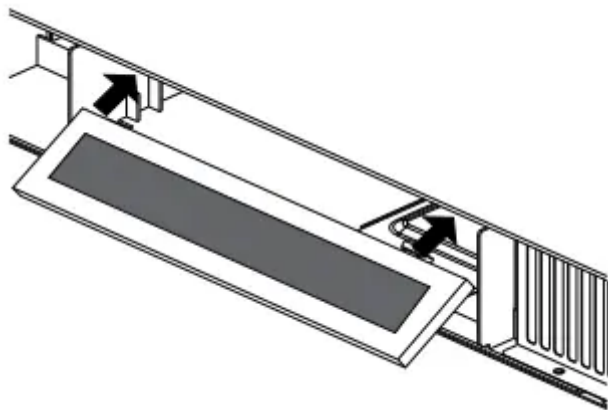

6. Press the bottom of charcoal filter to place it into the correct position.

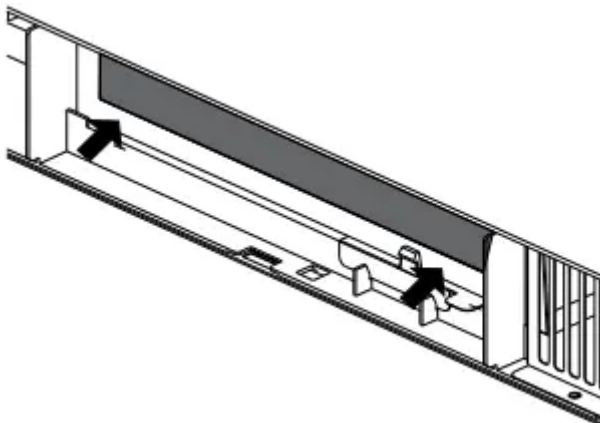

7. Put the vent grille bottom tabs into the slots then push the top of the vent grille into place.

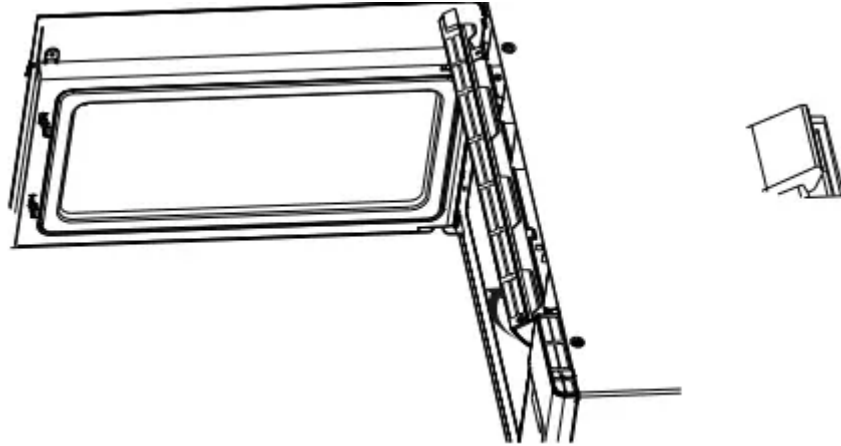

8. Reinstall the vent grille screws.

Oven light replacement

Remove the vent grill (see steps 1-4 in charcoal filter replacement section).

1. Remove the light cover by carefully pulling up on the front edge and pulling the cover forward.

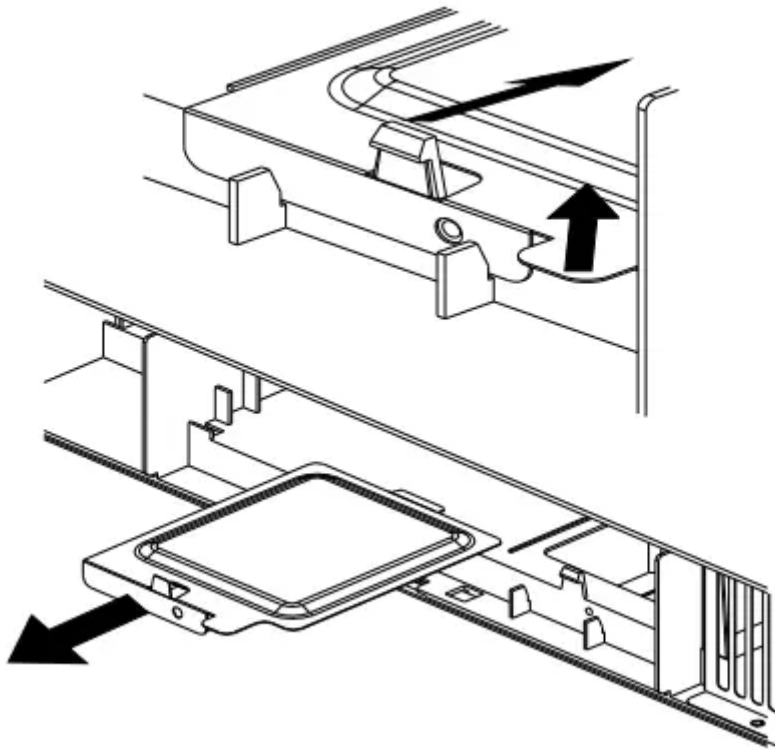

2. Remove the LED bracket and light assembly. Remove the LED light from the bracket by removing the mounting screw and replace only with part 5304499540. To order parts call 800-599-7569.

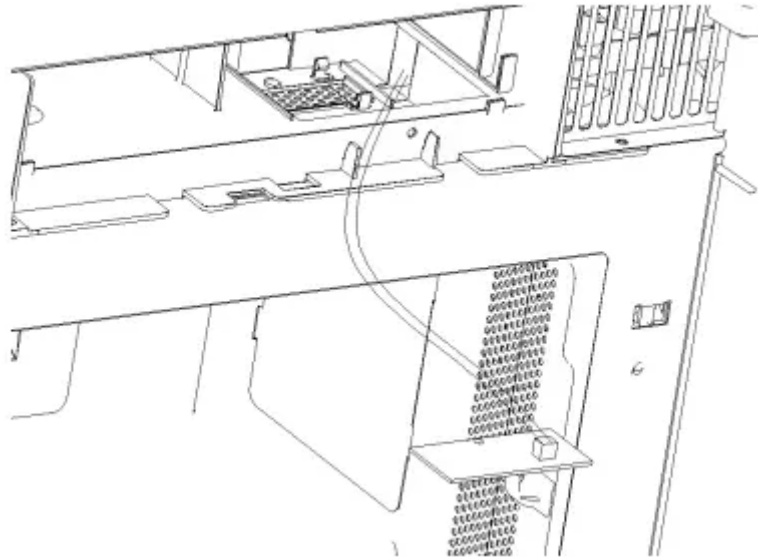

4. Reconnect LED light to the harness and place the LED light assembly back into the plastic housing.

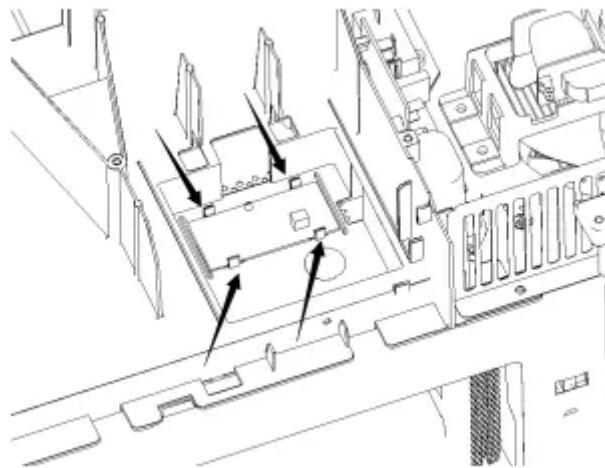

5 Replace the microwave oven light cover by carefully pushing into place (make sure the light cover rear tab is inserted into slot at rear).

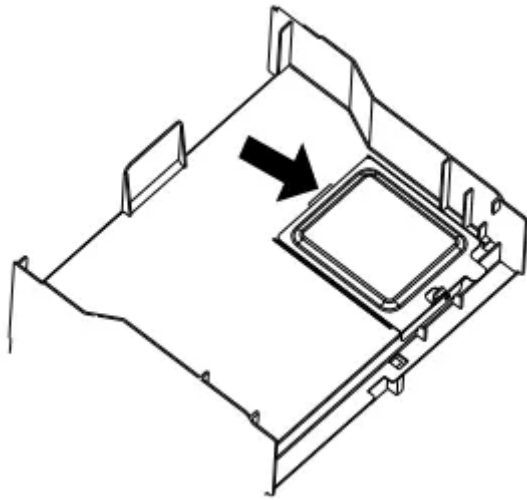

6. Replace the charcoal filter (if installed). Push the vent grill back into place (engaging both the bottom and top tabs) and replace the vent grill mounting screws.

Warning

This content is compiled from multiple sources and is provided for reference purposes only. It may not be complete or fully applicable to all situations. If you are unable to resolve your issue, please contact the product manufacturer or an authorized service provider for official support.