

CONTROLS & CONNECTIONS

Back of Sound Bar

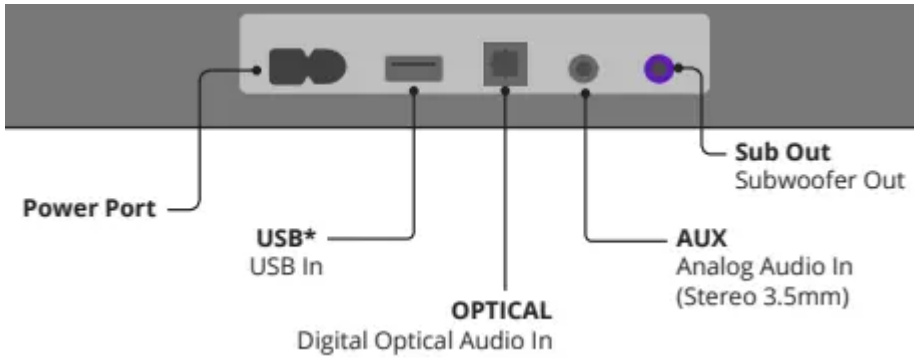

Top of Sound Bar

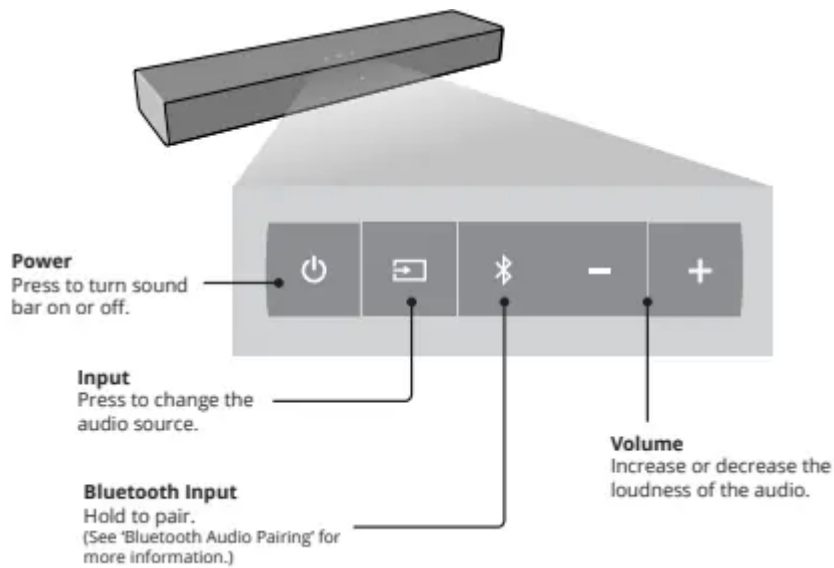

FIRST-TIME SETUP

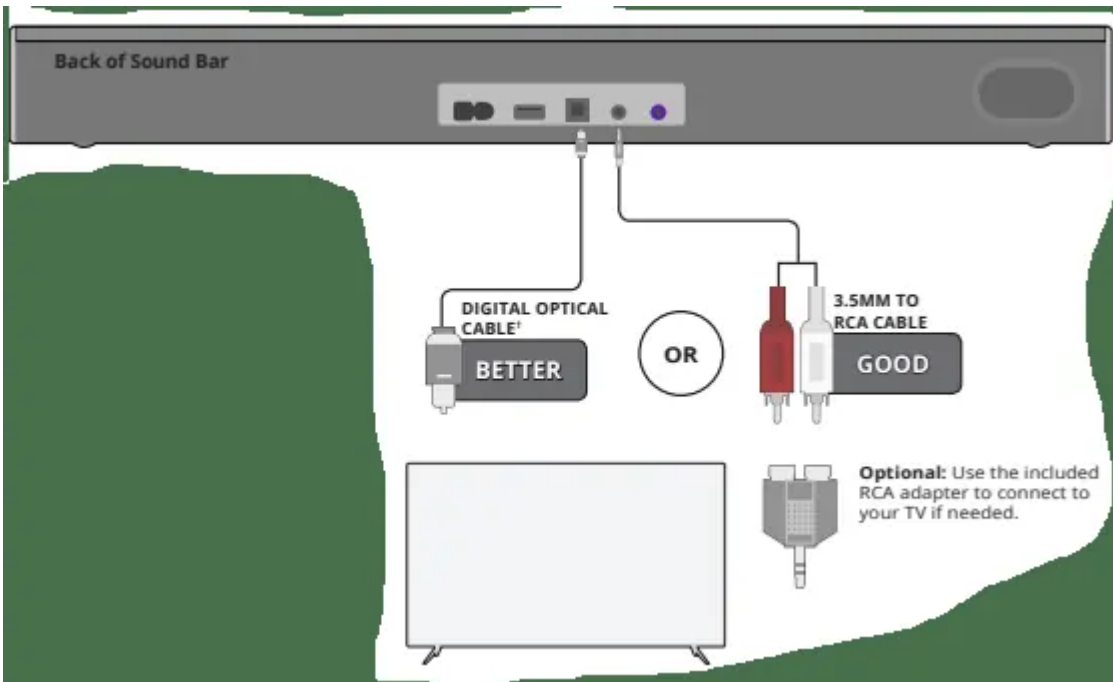

1. CHOOSE ONE CABLE* AND CONNECT IT TO YOUR TV

* Not all TVs have the audio outputs shown above. To connect the sound bar directly to your other devices (Blu-ray player, game system, etc.) see your device's user manual.

When using the digital input, if there is no audio:

(A) try setting the TV output to PCM



-or-

(B) connect directly to your Blu-ray/other source; some TVs do not pass through digital audio.

2. Connect the power cable to the sound bar AC IN as shown.

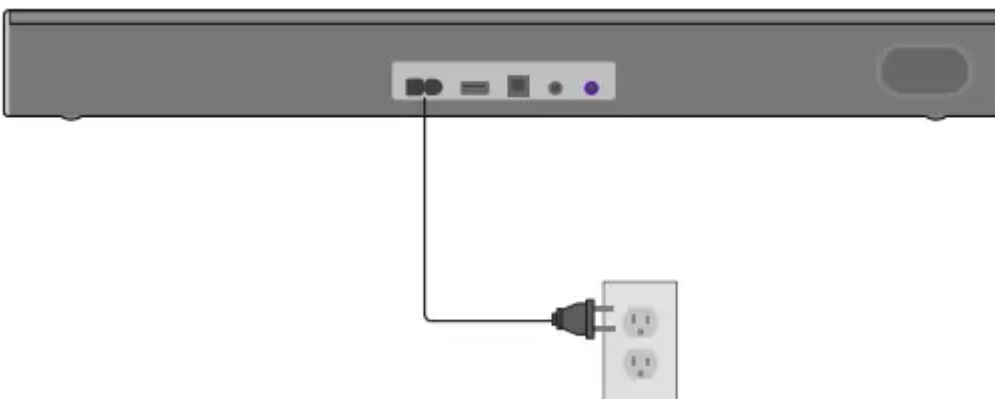
Plug the power cable into an electrical outlet.



<p>3.  Top</p>	<p>4.  Top</p>
<p>Remove the battery cover by gently sliding it away from the remote.</p>	<p>Insert the included batteries and gently slide the battery cover back into place.</p>

When needed, VIZIO recommends replacing the batteries that came with this remote with two, new Duracell 'AAA' alkaline batteries. 

5. Turn on your TV and sound bar. The sound bar will automatically begin searching for an active input.*

The LED indicator on the front of the sound bar will begin cycling through inputs until an audio source is detected.**



Tip: Pressing the INPUT button will stop the auto detect function.

You can press the INPUT button to switch between audio sources. For example, if you connected your TV to AUX , set the sound bar to AUX .

**Occurs only during first-time set up.*

***Auto detect function only occurs once when the sound bar is first powered on. To enable this feature again, you must do a Factory Reset (see the Using Button Combinations section for more information) or press and hold the INPUT button for 3 seconds.*

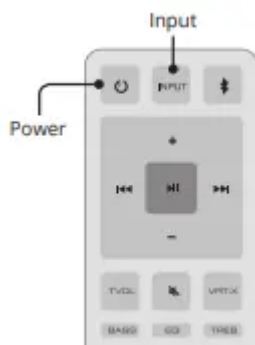

USING THE REMOTE

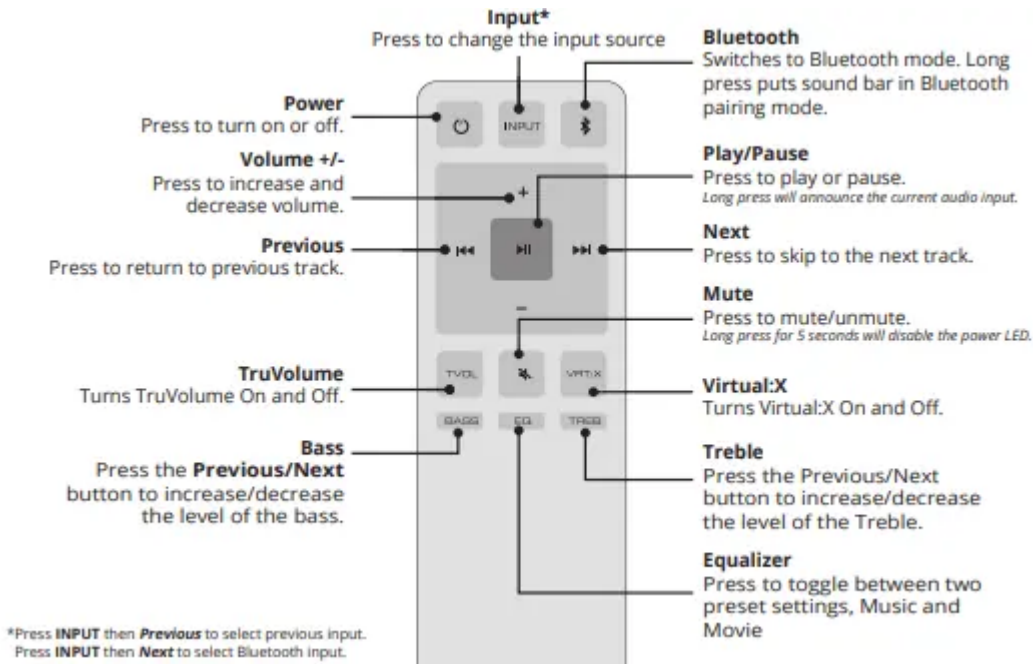

For the best surround sound experience, position the sound as shown.

The sound bar should be close to ear level (approx. 2-3 feet off the floor).

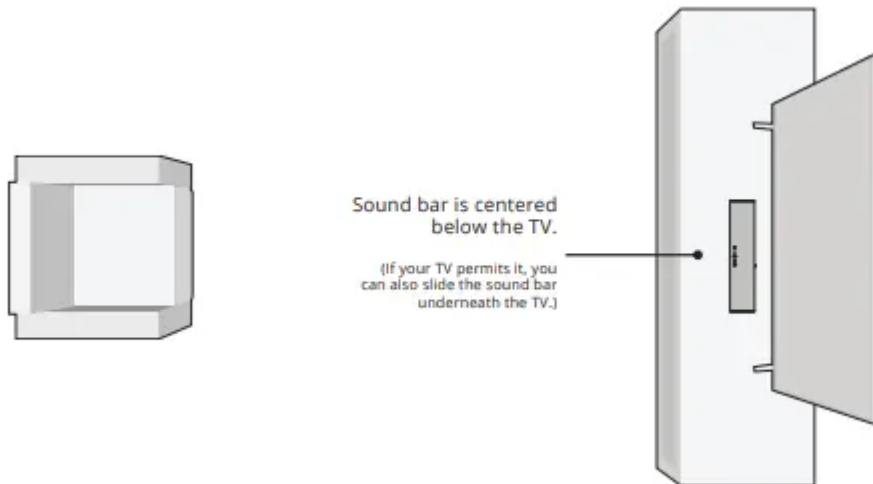



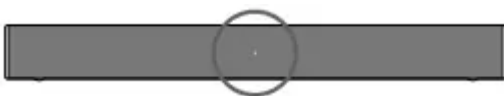

LED INDICATOR

The LED and speakers will react differently for each function.

LED Indicator is located here.

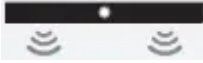

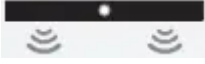
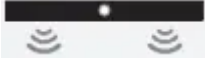

Function	LED/Speaker Behavior	Description
Input	 <p>The LED will blink a different color for each input:</p> <p>Green: AUX Amber: Optical Blue: Bluetooth Magenta: USB</p>	<p>Press the INPUT button on the remote to cycle through the available inputs:</p> <ul style="list-style-type: none"> • Analog Audio In - AUX Stereo 3.5mm • Digital Optical Audio In - Optical • Bluetooth • USB In - USB <p>Press and hold the INPUT button on the remote control for 3 seconds to enable the auto input detect function.</p>
Bluetooth Pairing	 <p>The LED will blink blue when searching and turn solid once a device is paired successfully.</p>	<p>Press and hold the  button on the remote. The sound bar will announce that it is "searching." It will be discoverable for 15 minutes. You can now search for the sound bar (VIZIO SB2020) using your Bluetooth device. The sound bar will power down if no device is found.</p> <p>Note: Set your Bluetooth device into pairing mode prior to the sound bar.</p>
DTS TruVolume On/Of	 <p>A high tone double beep indicates On, while a low tone double beep indicates Off.</p>	<p>Press the TVOL button to enable/disable TruVolume.</p> <p>When enabled (On), TruVolume provides a consistent and comfortable volume level for a more enjoyable listening experience.</p>
Virtual:X On/Of	 <p>A high tone double beep indicates On, while a low tone double beep indicates Off.</p>	<p>Press the VRT:X button to enable/disable Virtual:X. When enabled (On), all inputs will produce a virtual sound technology that simulates the effect of having overhead sound. When disabled (Off), all sources will playback in stereo.</p>
Equalizer Mode	 <p>A high tone double beep indicates Movie mode, while a low tone double</p>	<p>Press the EQ button to toggle between two preset equalizer settings: Music and Movie.</p> <p>Note: Movie mode is on by default.</p>

	beep indicates Music mode.	
Treble Levels	 <p>High tone double beep: Max level</p> <p>Medium tone single beep: Mid level</p> <p>Low tone double beep: Minimum level</p>	<p>Press the TREBLE button then press the Next/Previous button to increase/ decrease the treble level.</p> <p>Note: Mid level is the default setting.</p>
Bass Levels	 <p>High tone double beep: Max level</p> <p>Medium tone single beep: Mid level</p> <p>Low tone double beep: Minimum level</p>	<p>Press the BASS button then press the Next/Previous button to increase/ decrease the bass level.</p> <p>Note: Mid level is the default setting.</p> <p>If a subwoofer is connected, adjusting the bass level will also adjust the subwoofer level. Consult your subwoofer's user manual for additional adjustments that may optimize your listening experience.</p>

PROGRAMMING THE SOUND BAR

You can program the sound bar to accept TV remote IR commands.



Function	LED Behavior	Description
Learn Volume Down	 <p>The LED indicator will flash yellow when learning and will turn solid once it has successfully recognized the TV remote.</p>	Press the Play + Volume Down buttons on the remote to put the sound bar into learning mode. While the sound bar is in learning mode, press the Volume Down button on the TV remote control while pointing the remote at the sound bar.
Learn Volume Up	 <p>The LED indicator will flash amber when learning and will turn solid once it has successfully recognized the TV remote.</p>	Press the Play + Volume Up buttons on the remote to put the sound bar into learning mode. While the sound bar is in learning mode, press the Volume Up button on the TV remote control while pointing the remote at the sound bar.
Learn Mute	 <p>The LED indicator will flash white when learning and will turn solid once it has successfully recognized the TV remote.</p>	Press the Play + Mute buttons on the remote to put the sound bar into learning mode. While the sound bar is in learning mode, press the Mute button on the TV remote control while pointing the remote at the sound bar.

USING BUTTON COMBINATIONS

Buttons are located here.

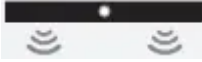

There are 3 functions that are triggered by 3 different button combinations on the sound bar.

Function	LED Behavior	Description
Factory Reset	 LED will flash 3 times.	Reset the sound bar to the factory default settings. To perform a Factory Reset, Press and Hold the Bluetooth(📶) and Volume Down (—) buttons for 5 seconds. Note: This will erase all settings and preferences that you have set.
VIZIO TV Remote Control	 A high tone double beep indicates On, while a low tone double beep indicates Off.	Enable/disable the use of a VIZIO TV remote control to power on and adjust the volume of the sound bar. To enable/disable this function, Press and Hold the Power (🔌) and Volume Up (+) buttons for 5 seconds. Note: This function is enabled by default.
Eco Power Mode	 A high tone double beep indicates On, while a low tone double beep indicates Off.	When the Eco Power setting is enabled, the sound bar will automatically power down after a period of inactivity. When disabled, the sound bar will remain powered on until you turn it off. To enable/disable this function, Press and Hold the Power (🔌) and Volume Down (—) buttons for 5 seconds. Note: Eco Power Mode setting is enabled by default.

BLUETOOTH PAIRING

To pair the sound bar with a Bluetooth device:

1. Press and hold the Bluetooth button 📶 on the sound bar for five (5) seconds or select the Bluetooth button on the remote. When the sound bar is in Bluetooth Pairing Mode, the LED Indicator on the front display panel will turn blue and start blinking. Once the device is paired, the LED Indicators will stop blinking.
2. You can now search for the sound bar (VIZIO SB2020) using your Bluetooth device. For more information, refer to the user documentation that came with the device.
3. Play audio from your Bluetooth device. Volume can be controlled on your source device and the sound bar.

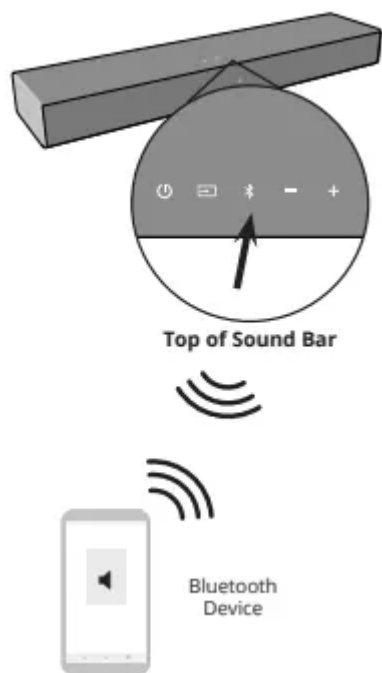

USING BLUETOOTH MODE

Your sound bar supports music streaming from smartphones, tablets, and computers with Bluetooth capability. Device compatibility will vary, see your device's documentation for more information.

- Once you have paired your source device to the sound bar, as long as you stay within range of the sound bar, your device should remain paired.
- If the input is changed, the Bluetooth device will disconnect.
- If the source is changed back to Bluetooth, any paired Bluetooth device will reconnect automatically.



Your sound bar is not equipped with a microphone, so it cannot operate as a hands-free device for a smartphone.

Maximizing Signal

A Bluetooth signal has a range of up to 30 feet. Keep in mind that Bluetooth is a compressed audio format, so streamed music may lose some integrity when compared to a wired connection.

Try the following if your sound quality is less than optimal:

- If you hear any break-up or disconnect while streaming music from your device, move the source device closer to the sound bar.
- Be sure that there are no solid obstructions in the line-of-sight between the sound bar and the source device.

- Other wireless devices can affect Bluetooth range, including wireless security cameras, wireless video baby monitors, cordless phones, and microwave ovens. Turning off or moving these devices may improve Bluetooth range.

 Reduce the volume levels on your device and on the sound bar before pressing Play. High volume levels can damage your hearing.

ADVANCED SETUP

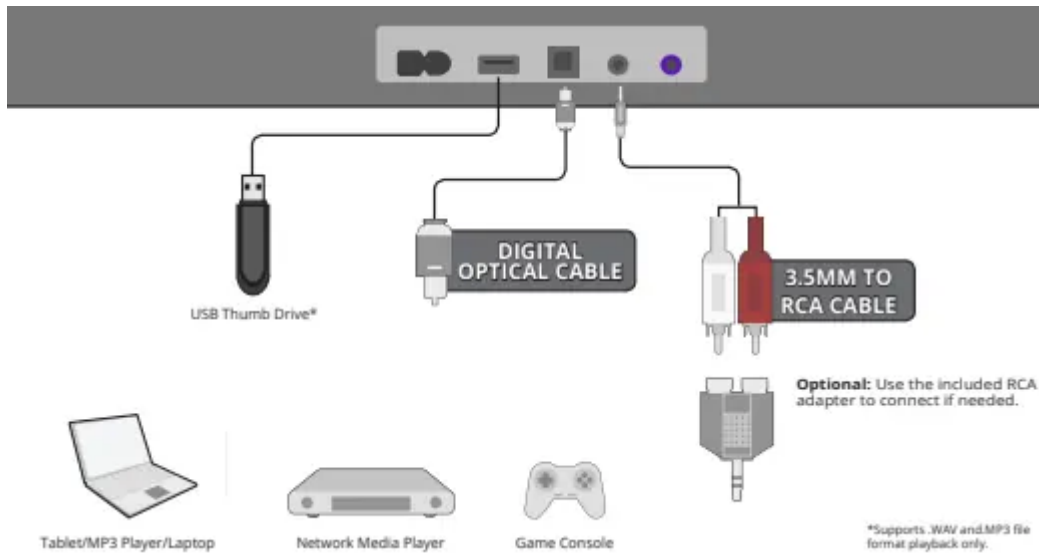

HELP & TROUBLESHOOTING



<p>There is no power.</p>	<ul style="list-style-type: none"> • Press the POWER button on the remote control or on the top of your sound bar. • Ensure the power cord is securely connected. • Plug a different device into the electrical outlet to verify that the outlet is working correctly.
<p>There is no sound.</p>	<ul style="list-style-type: none"> • Increase the volume. Press Volume Up on the remote control or on the top of your sound bar. • Press MUTE on the remote to ensure the sound bar is not muted. • Press INPUT on the remote or on the top of your sound bar to select a different input source. • When using the optical input, if there is no audio: (A) Try setting the TV output to PCM or (B) Connect directly to your Blu-ray/other source, some TVs do not pass through digital audio. • On the optical input, the input LEDs will flash rapidly and vocally announce "Format Not Supported" if an unsupported format is present. Set the source to output PCM. • Your TV may be set to variable audio output. Confirm that the audio output setting is set to FIXED or STANDARD, not VARIABLE. Consult your TV's user manual for more detailed information. • If using Bluetooth, ensure that the volume on your source device is turned up and that the device is not muted.
<p>I hear buzzing or humming.</p>	<ul style="list-style-type: none"> • Ensure all cables and wires are securely connected. • Connect a different source device (TV, Blu-ray player, etc) to see if the buzzing persists. If it does not, the problem may be with the original device. • Connect your device to a different input on the sound bar.
<p>The remote isn't working</p>	<ul style="list-style-type: none"> • Replace the remote batteries with new ones. • Point the remote directly at the center of the Sound Bar when pressing a button. • If using a Bluetooth connection, some of the buttons on the remote may not be supported by the streaming application. (e.g., Pandora doesn't support the Back button.)



Warning

This content is compiled from multiple sources and is provided for reference purposes only. It may not be complete or fully applicable to all situations. If you are unable to resolve your issue, please contact the product manufacturer or an authorized service provider for official support.

Document generated by [ManualsFile](#)