

PRODUCT OVERVIEW

Parts

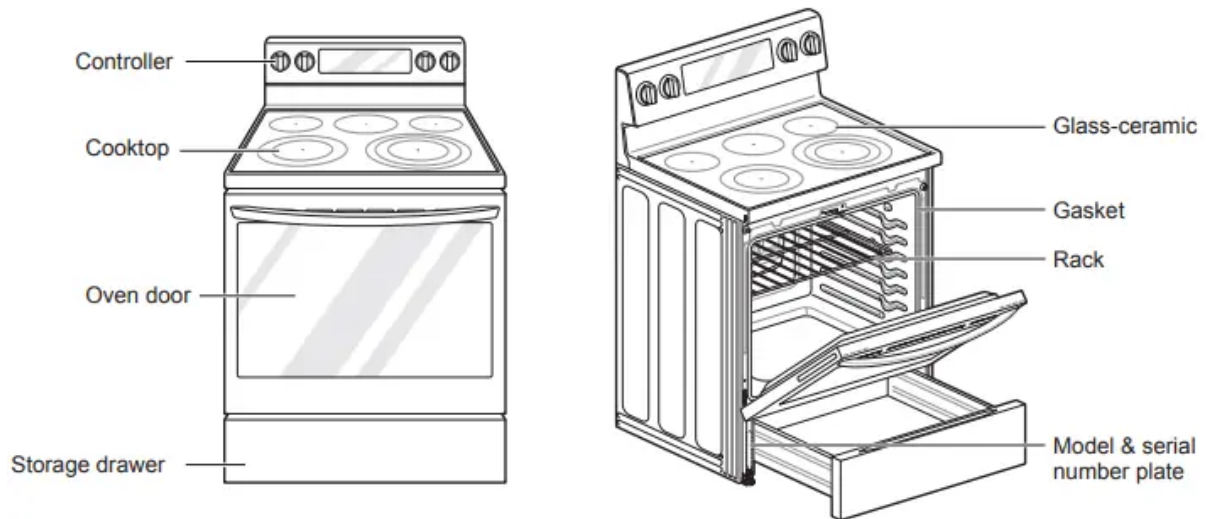

Accessories

Included Accessories



- Standard Rack
- Model LREL6325* (3ea)
 - Model LREL6323*/LREL6321* (2ea)

Optional Accessories



Grid



Broiler pan



Air fry tray

INSTALLATION

Installation Overview

Please read the following installation instructions first after purchasing this product or transporting it to another location.

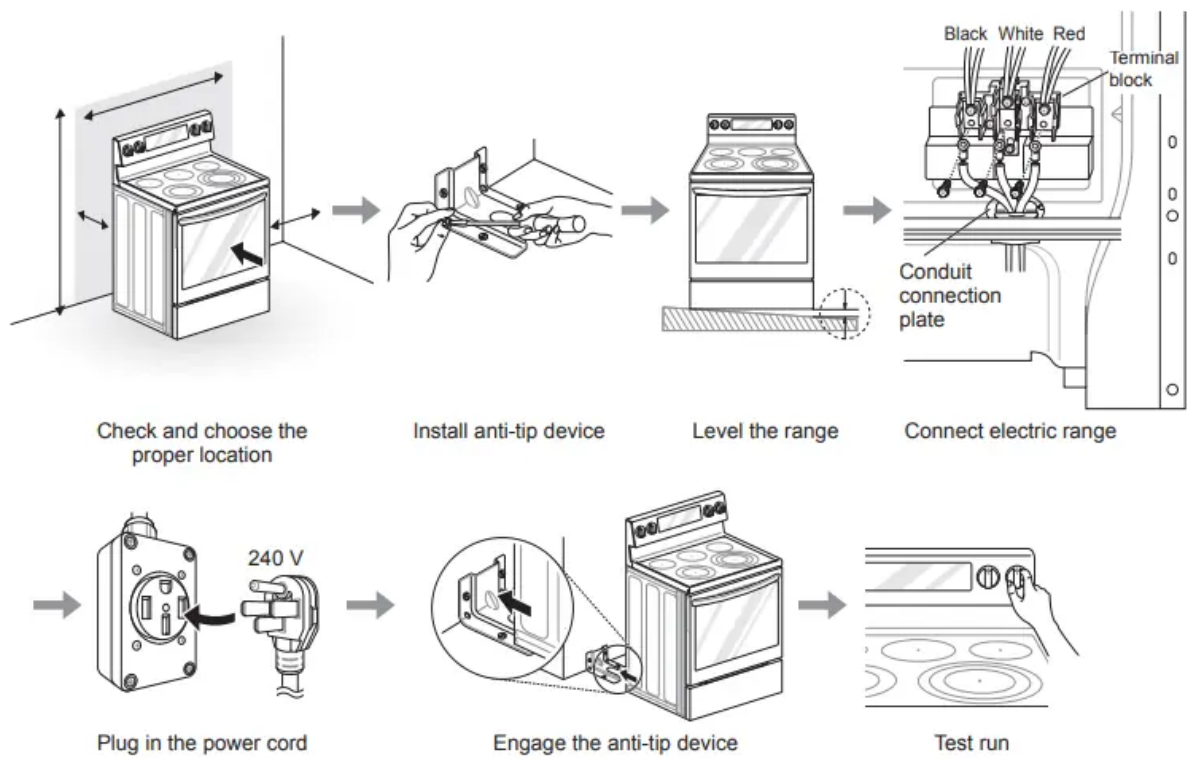

Product Specifications

The appearance and specifications listed in this manual may vary due to constant product improvements.

Oven Range Models	LREL6325*	LREL6323*	LREL6321*
Electrical requirements	120/240 V: 12.9 kW, 120/208 V: 9.7 kW		120/240 V: 13.1 kW, 120/208 V: 9.8 kW
Description	Electric Single Oven Range		
Exterior Dimensions	29 7/8" (W) x 46 1/2" (H) x 26 1/2" (D) (D with door closed and excluding door handle) 75.9 cm (W) x 118.1 cm (H) x 67.4 cm (D) (D with door closed and excluding door handle)		
Height to cooking surface	36" (91.3 cm)		
Total capacity	6.3 cu.ft.		

Before Installing the Range

WARNING: Tip - Over Hazard A child or adult can tip the range and be killed. Verify the anti-tip bracket has been installed. Ensure the anti-tip bracket is engaged when the range is moved. Do not operate the range without the anti-tip bracket in place. Failure to follow these instructions can result in death or serious burns to children and adults

To check that leveling leg is inserted into anti-tip bracket, grasp the top rear edge of the range and carefully attempt to tilt it forward.

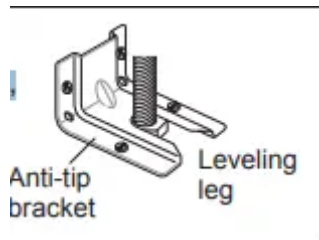

Tools Needed



Phillips screwdriver



Flat-blade screwdriver



1/4" Nut driver

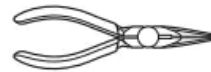

Pliers



Tape measure



Level



Adjustable wrench



Drill



Safety glasses



Gloves

Parts Provided



Template (1)



Anti-tip bracket kit (1)



Anchor sleeves (4)



Lag bolts (4)

Parts not Provided



4-Wire cord or
3-Wire cord
(UL approved 40 or 50
AMP)



Strain relief
**(For conduit
installations only)**

NOTE

- Observe all governing codes and ordinances.
- Have the installer show you the location of the circuit breaker or fuse. Mark it for easy reference.
- As when using any appliance generating heat, there are certain safety precautions you should follow.
- Be sure your range is installed and grounded properly by a qualified installer or service technician.

Installing the Range

Unpacking and Moving the Range

- Remove packing material, protective film, tape and any temporary labels from your range before using. Do not remove any warning-type labels, the model and serial number label, or the Tech Sheet that is located on the back of the range.

- To remove any remaining tape or glue, rub the area briskly with your thumb. Tape or glue residue can also be easily removed by rubbing a small amount of liquid dish soap over the adhesive with your fingers. Wipe with warm water and dry.
- Do not use sharp instruments, rubbing alcohol, flammable fluids, or abrasive cleaners to remove tape or glue. These products can damage the surface of your range.
- Your range is heavy and can be installed on soft floor coverings such as cushioned vinyl or carpeting. Use care when moving the range on this type of flooring. Use a belt when moving the range to prevent damaging the floor. Or slide the range onto cardboard or plywood to avoid damaging the floor covering.

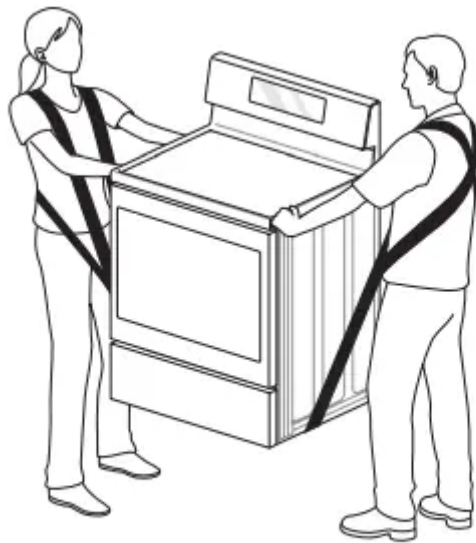

Choosing the Proper Location

CAUTION

- Avoid placing cabinets above the range. To minimize the hazard caused by reaching over the open flames of operating burners, install a ventilation hood over the range that projects forward at least five inches beyond the front of the cabinets.
- Make sure wall covering, countertop and cabinets around the range can withstand the heat (up to 194 °F) generated by the range. Discoloration, delamination or melting may occur. This range has been designed to comply with the maximum allowable wood cabinet temperature of 194 °F.
- Before installing the range in an area covered with linoleum or other synthetic floor covering, make sure the floor covering can withstand temperatures of at least 200 °F (93 °C).
- Use an insulated pad or 1/4 in. (0.64 cm) plywood under the range if installing the range over carpeting.

The range should always be plugged into its own individual properly grounded electrical outlet. This prevents overloading house wiring circuits which could cause a fire hazard from overheated wires. It is recommended that a separate circuit serving only this appliance be provided

Mobile Home - Additional Installation Requirements: The installation of this range must conform to the Manufactured Home Construction and Safety Standard, Title 24 CFR, Part 3280 (formerly the Federal Standard for Mobile Home Construction and Safety, Title 24, HUD Part 280), or when such standard is not applicable, the Standard for Manufactured Home Installations, ANSI A225.1/NFPA 501A or with local codes.

- When this range is installed in a mobile home, it must be secured to the floor during transit. Any method of securing the range is adequate as long as it conforms to the standards listed above.
- A four-wire power supply cord or cable must be used in a mobile home installation.

Dimensions and Clearances

NOTE: Important - Save for the use of the local electrical inspector.

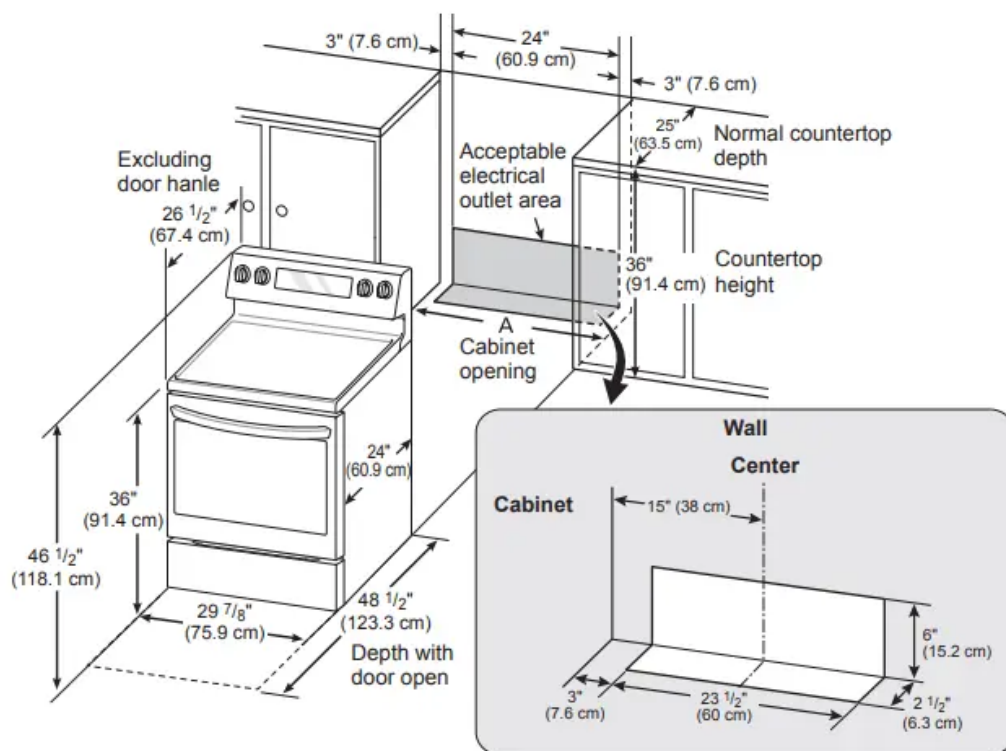

A = 30" (76.2 cm) For U.S.A
 = 30" (76.2 cm) ~ 31" (78.7 cm) For CANADA

For installation in Canada, a free-standing range is not to be installed closer than 15/32" (12 mm) from any adjacent surface.



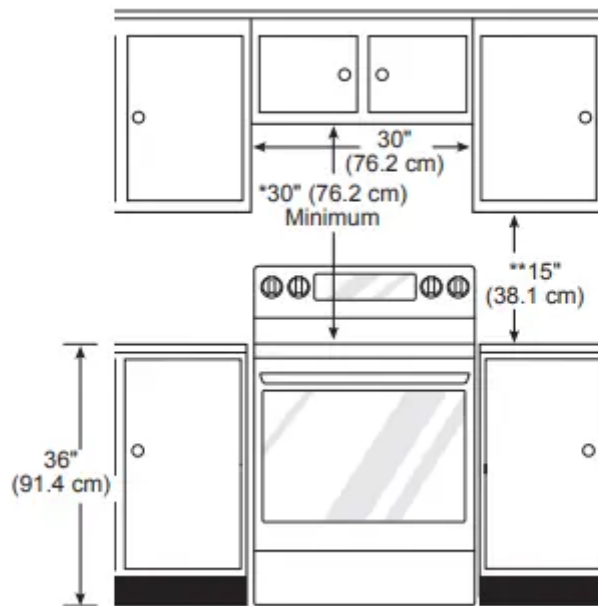

Minimum Dimensions

- * 30" (76.2 cm) minimum clearance between the top of the cooking surface and the bottom of an unprotected wood or metal cabinet; or 24" (60.9 cm) minimum when bottom of wood or metal cabinet is protected by not less than 1/4" (6.4 cm) flame retardant millboard covered with not less than no. 28 MSG sheet steel, 0.015" (0.381 mm) stainless steel, 0.024" (0.610 mm) aluminum or 0.020" (0.508 mm) copper.
- ** 15" (38.1 cm) minimum between countertop and adjacent cabinet bottom.

Installing the Anti-tip Device

WARNING

- Tip - Over Hazard: A child or adult can tip the range and be killed. Verify the anti-tip bracket has been installed. Ensure the anti-tip bracket is engaged when the range is moved. Do not operate the range without the anti-tip bracket in place. Failure to follow these instructions can result in death or serious burns to children and adults.
- To check that leveling leg is inserted into anti-tip bracket, grasp the top rear edge of the range and carefully attempt to tilt it forward

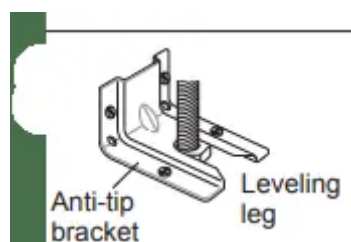

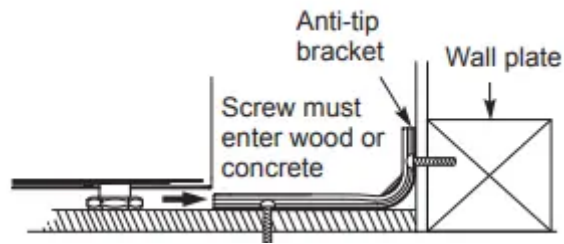

Locate the anti-tip bracket using the template: An anti-tip bracket is packaged with the template. The instructions include necessary information to complete the installation. Read and follow the range installation instruction sheet (template).

Leveling the Range

- Level the range by adjusting the leveling legs with a wrench. Extending the legs slightly may also make it easier to insert the rear leg into the anti-tip bracket.

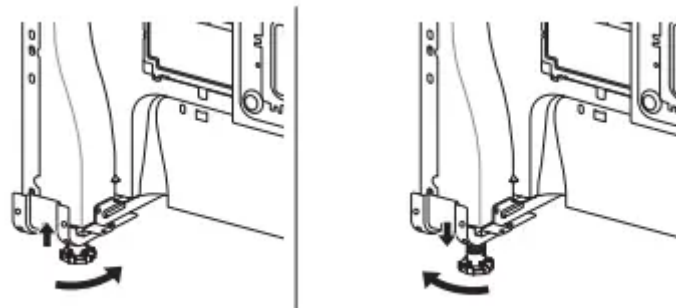

- Use a level to check your adjustments. Place the level diagonally on the oven rack, and check each direction for level.
- First check direction 1.
- Then check direction 2. If the level doesn't show level on the rack, adjust the leveling legs with a wrench.

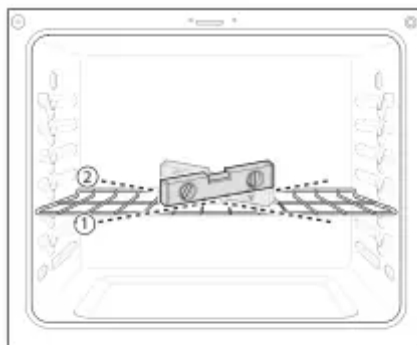

Connecting Electricity

Electrical Requirements



- This appliance must be installed and grounded on a branch circuit by a qualified technician in accordance with the National Electrical code ANSI/NFPA NO. 70 - latest edition.
- All wiring should conform to Local and NEC codes. This range requires a single-phase, 3 wire, A.C 120/208 V or 120/240 V 60 Hz electrical system. Use only a 3-conductor or a 4-conductor UL- listed range cord with closed-loop terminals, open-end spade lugs with upturned ends or similar termination. Do not install the power cord without a strain relief.
- A range cord rated at 40 amps with 120/240 minimum volt range is required. If a 50 amp range cord is used, it should be marked for use with 13/8" diameter connection openings. This appliance may be connected by means of a conduit or power cord. If a conduit is being used, go to page 17 for 3 wire conduit connections or 4 wire conduit connections

WARNING

- Allow 2 to 3 ft (61.0 cm to 91.4 cm) of slack in the line so that the range can be moved if servicing is ever necessary.
- The power supply cord and plug should not be modified. If it will not fit the outlet, have a proper outlet installed by a qualified electrician.
- Using an extension cord to connect the power is prohibited. Connect the power cord and plug directly.
- Electrical ground is required on this appliance.
- Make sure that the power cord is not pinched by the range or heavy objects. Failure to do so can result in serious burns or electrical shock

Specified power-supply-cord kit rating				
Range rating, watts		Specified rating of power supply-cord kit, amperes	Diameter (inches) of Range connection Opening	
120/240 volts 3-wire	120/208 volts 3-wire		Power cord	Conduit
8,750 - 16,500	7,801 - 12,500	40 or 50A	1 3/8"	1 1/8"
16,501 - 22,500	12,501 - 18,500	50	1 3/4"	1 3/8"

3, 4 - Wire electrical wall Receptacle

	4 Wire receptacle (14-50R)
	3 Wire receptacle (10-50R)

Connecting the Power Cord: The rear access cover must be removed. Loosen the two screws with a screwdriver. The terminal block will then be accessible.

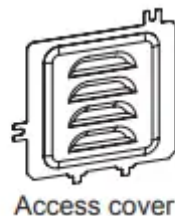

- Use the cord/conduit connection plate to install the power cord or conduit. Leave the connection plate as installed for power cord installations. Remove the connection plate for conduit installations and use the smaller 1 1/8 in. (2.8 cm) conduit hole instead of the 1 3/8 in. (3.5 cm) power cord hole.

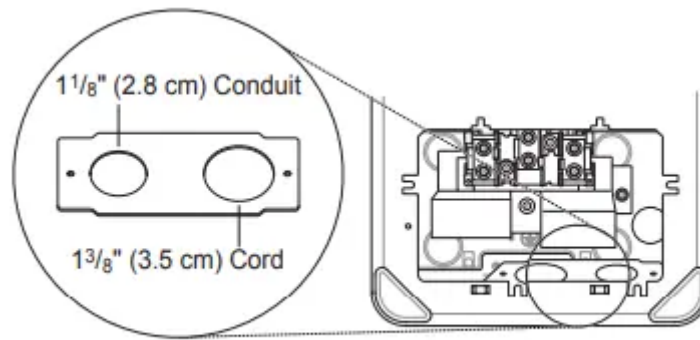

Remove the Conduit connection plate

- For power cord installations, hook the strain relief over the 13/8 in. (3.5 cm) power cord hole located below the rear of the oven. Insert the power cord through the strain relief and tighten it.

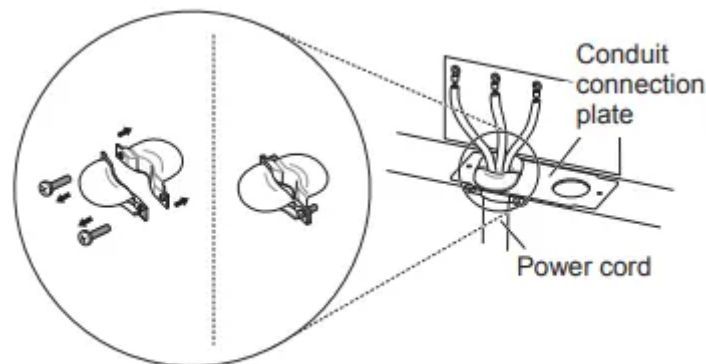

Assembling power cord strain relief at the 13/8" opening

- For conduit installations, insert the conduit strain relief in the 11/8 in. (2.8 cm) conduit hole. Then install the conduit through the body of the strain relief and fasten the strain relief with its ring.

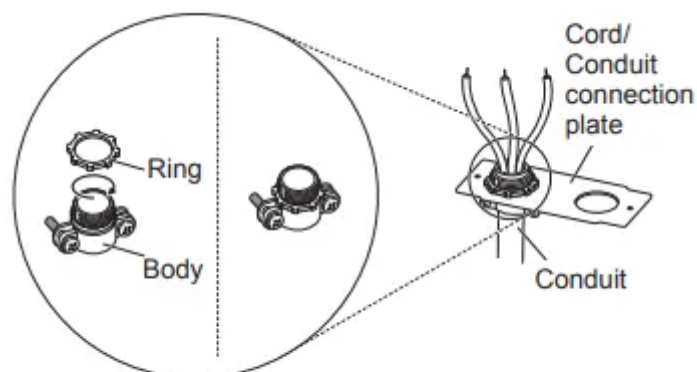

Assembling conduit cord strain relief at the 11/8" opening

3-Wire Connection : Power Cord

Install the power cord as follows: For power cord installations, hook the strain relief over the power cord hole (13/8") located below the rear of the oven. Insert the power cord through the strain relief and tighten it.

Do not install the power cord without a strain relief.

1. Remove the lower 3 screws from the terminal block and retain them.
2. Insert the 3 screws through each power cord terminal ring and into the lower terminals of the terminal block. Make sure that the center (neutral) wire, which is white, is connected to the center lower position of the terminal block.
3. Tighten the 3 screws securely into the terminal block. Do not remove the ground strap connections

3-wire connection

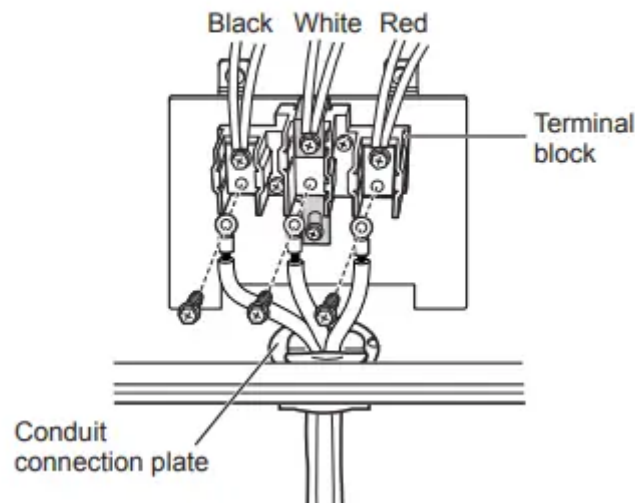

If screws are not tightened securely, it can result in electrical spark and severe personal injury or death.

4-Wire Connection : Power Cord

Install the power cord as follows: Do not install the power cord without a strain relief.

1. Remove the lower 3 screws from the terminal block and retain them.
2. Remove the ground screw and bend the end of the ground strap up so the slot is over the hole of the center screw removed in step 1.
3. Insert the ground screw into the power cord ground wire (green) terminal ring and secure it to the range frame.
4. Insert the 3 screws through each power cord terminal ring and into the lower terminals of the terminal block. Make sure that the white center (neutral) wire is connected to the center lower position of the terminal block.
5. Tighten the 3 screws securely into the terminal block. The center screw now attaches the bent up ground strap to the block.

4-wire connection

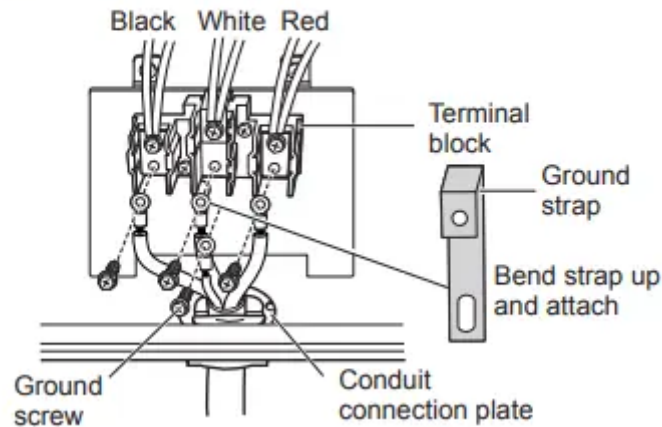

If screws are not tightened securely, it can result in electrical spark and severe personal injury or death.

3-Wire Connection: Conduit

Install the conduit as follows: Remove the conduit connection plate from the rear of the oven and rotate it. The conduit hole (1 1/8") must be used.

First, prepare the conduit wires as shown below.

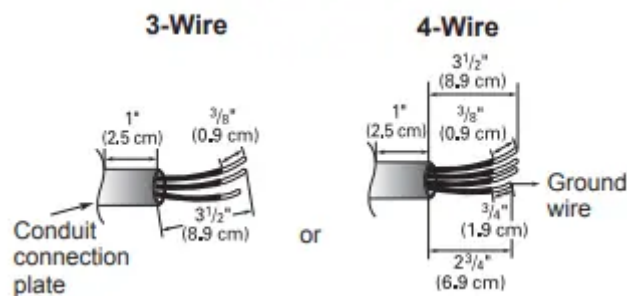

Second, install the conduit strain relief.

For conduit installations, purchase a strain relief and insert it in the 1 1/8 in. (2.8 cm) conduit hole. Then install the conduit through the body of the strain relief and fasten the strain relief with its ring. Reinstall the bracket.

For conduit connections: If the wire in the conduit is copper it must be 8 or 10 AWG wiring. If the wire in the conduit is aluminum it must be 6 or 8 AWG wiring.

1. Loosen the lower 3 screws from the terminal block.
2. Insert the bare wire (white/neutral) end through the center terminal block opening. Do not remove the ground strap connections.
3. Insert the two side bare wire ends into the lower left and the lower right terminal block openings. Tighten the 3 screws securely into the terminal block. (approximately 35 - 50 IN-LB)

3-wire connection

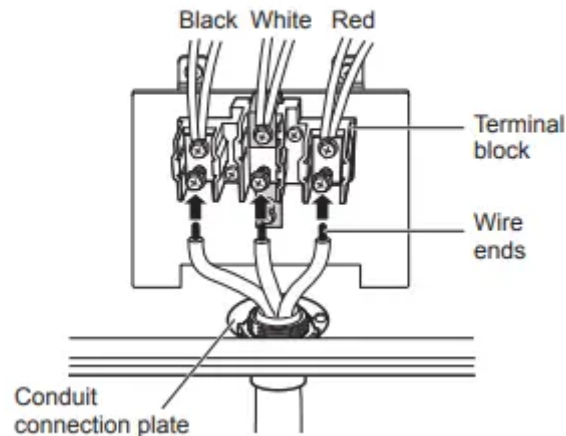

If screws are not tightened securely, it can result in electrical spark and severe personal injury or death.

4-Wire Connection: Conduit

1. Follow the instructions for installing the conduit under 3-Wire Connection: Conduit until the strain relief and bracket are installed. Do not install the conduit without a strain relief.
2. Loosen the 2 lower left and right screws from the terminal block. Remove the lower 2 center screws. Do not discard any screws.
3. Remove the ground screw and bend the end of the ground strap up so the slot is over the hole of the center screw removed in step 1.
4. Attach the ground (green) bare wire end to the range frame and secure it in place with the ground screw.
5. Insert the bare wire (white/neutral) end through the center terminal block opening. The center screw now attaches the bent up ground strap to the block.
6. Insert the two side bare wire ends into the left and the right terminal block openings. Tighten the 3 screws securely into the terminal block. (approximately 35 - 50 IN-LB)

4-wire connection

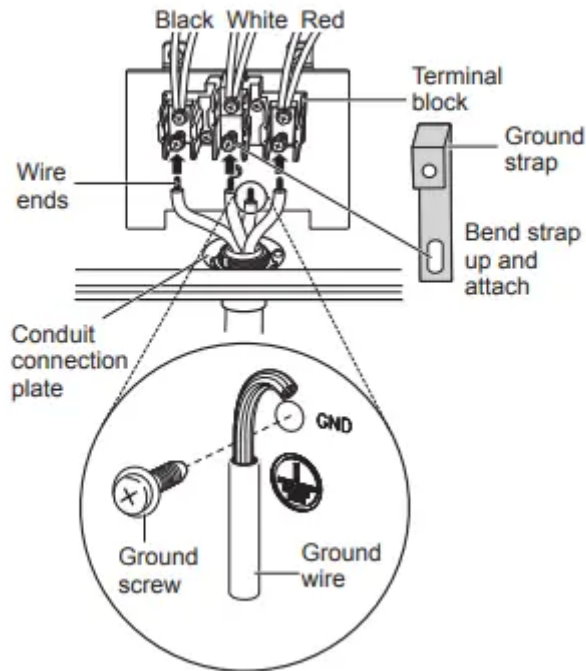

If screws are not tightened securely, it can result in electrical spark and severe personal injury or death.

Engaging the Anti-tip Device

- Move the range close enough to the opening to plug into the receptacle.
- Slide the range into position ensuring that the back leg slides under the anti-tip bracket. The range should sit flush against the back wall when properly installed.
- Carefully attempt to tip the range forward to ensure that the anti-tip bracket is engaged properly. If properly installed, the anti-tip bracket will prevent the range from being tipped. If the range can be tipped, reinstall the range until the anti-tip bracket is properly installed and the range will not tip forward.
- Turn on electrical power. Check the range for proper operation.



Test Run

Check if the range is properly installed and run a test cycle.

1. Before using the cooktop for the first time, clean it with a ceramic cooktop cleaner. This helps protect the top and makes cleanup easier.
2. Press Clear/Off to start test.
3. Turn on each burner to the Hi setting to check that the surface heating elements are working properly. The elements should glow red and radiate heat, and they should cycle on and off periodically even when the setting is in the Hi position. This cycling prevents the glass-ceramic from being cracked by thermal shock. **IMPORTANT** : The warming zone does not consume enough power to glow red.
4. After checking all the surface heating elements, check the locking system by pressing Clear/Off for three seconds. The oven door should lock. Press Clear/Off for three seconds to disable Lockout. The Lockout function should disable controls for the oven.
5. Now check the oven's operation. Press Bake and press the number keys to set the oven temperature to 350 °F.
6. The oven should finish preheating in 15 minutes. The convection fan should operate while the oven is preheating. Model LREL6325* 7 After checking the oven's operation, turn the temperature up to 450 °F and leave the oven on for at least an hour to help remove any oil which might cause smoke and odors when first using the oven.

OPERATION

Control Panel Overview

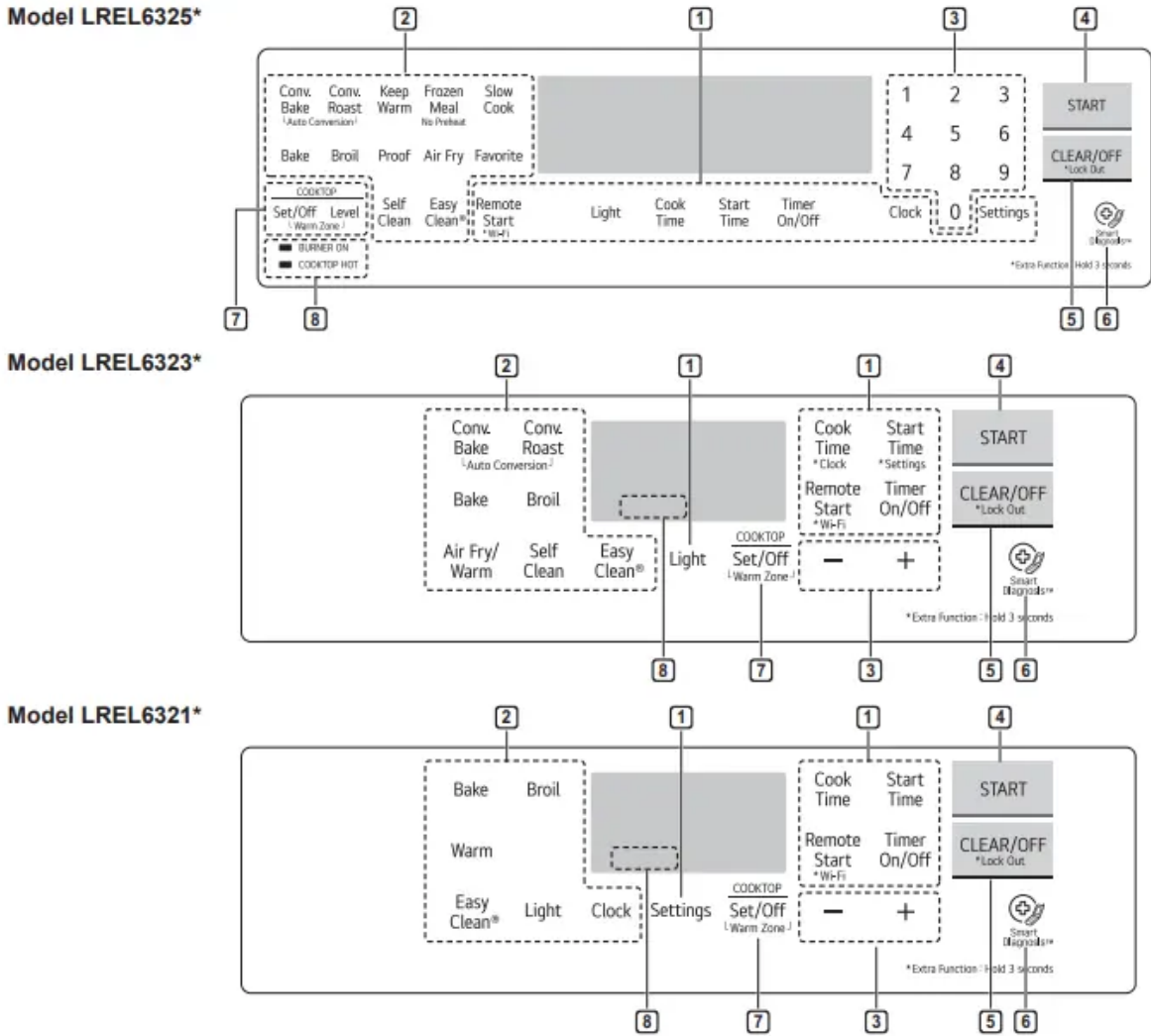

NOTE For best results, press buttons in the center, even when activating a button's secondary function. The buttons may not work properly if pressed too far from the center.

- 1** Features
- 2** Oven Control
- 3** Number Keys or +/- buttons
- 4** Start button
- 5** Clear Off / Lockout button
- 6** Smart Diagnosis™
- 7** Cooktop Control
- 8** COOKTOP HOT Indicator

The COOKTOP HOT indicator appears in the display as long as any surface cooking area is too hot to touch. It remains on after the element is turned off and until the surface has cooled to approximately 150 °F.

The COOKTOP HOT indicator also appears during the self clean cycle.



Flashing Time If your oven displays a flashing clock, press Clock or press any key to stop the flashing.

Changing Oven Settings

Clock: The clock must be set to the correct time of day in order for the automatic oven timing functions to work properly

- Model LREL6325*
 1. Press Clock.
 2. Press numbers to enter the time.
 3. Press Start.
- Model LREL6323* / LREL6321*
 1. Model LREL6323* Press and hold Cook Time for 3 seconds. Model LREL6321* Press Clock.
 2. Press the +/- buttons to set the time.
 3. Press Start.

Oven Light: The interior oven light automatically turns on/off when the door is opened and closed. Press Light or knock on the door glass twice to manually turn the oven light on/off.

Minimum & Maximum Default Settings

- All of the features listed have a minimum and a maximum time or temperature setting that may be entered into the control. A beep sounds each time a button is pressed.
- Two short tones sound if the entry of the temperature or time is below the minimum or above the maximum setting for the feature.

Feature		min. Temp. / Time	max. Temp. / Time	Default
Clock	12 Hr.	1:00 Hr. / min.	12:59 Hr. / min.	
	24 Hr.	0:00 Hr. / min.	23:59 Hr. / min.	
Timer (LREL6325*)		0:01 min. / sec.	11:59 Hr. / min.	
Timer (LREL6323*/ LREL6321*)		0:10 min. / sec.	11:59 Hr. / min.	
Cook Time		0:01 min.	11:59 Hr. / min.	
Conv. Bake		300 °F / 150 °C	550 °F / 285 °C	350 °F (325 °F)/ 12 Hr.
Conv. Roast		300 °F / 150 °C	550 °F / 285 °C	350 °F (325 °F)/ 12 Hr.
Broil		Lo	Hi	Hi / 3 Hr.
Bake		170 °F / 80 °C	550 °F / 285 °C	350 °F / 12 Hr.
Favorite ① - Bread		170 °F	550 °F	375 °F / 12 Hr.
Favorite ② - Meat		300 °F	550 °F	325 °F / 12 Hr.
Favorite ③ - Chicken		300 °F	550 °F	350 °F / 12 Hr.
Frozen Meal		300 °F	550 °F	400 °F / 12 Hr.
Air Fry		300 °F	550 °F	400 °F / 12 Hr.
Slow Cook		Lo	Hi	Hi / 12 Hr.
Proof				12 Hr.
Warm				3 Hr.
Self Clean (on some models)		3 Hr.	5 Hr.	4 Hr.
EasyClean®				10 min.

- Using Auto Conversion (Model LREL6325*/ LREL6321*)
- Default cook mode times are without setting cook time.

Timer On/Off

- The Timer On/Off feature serves as an extra timer in the kitchen that beeps when the set time has run out. It does not start or stop cooking.
- The Timer On/Off feature can be used during any of the other oven control functions

Setting the Timer

1. Press Timer On/Off button once to set the time in hours and minutes, or press the button twice to set the time in minutes and seconds. TIMER flashes in the display.
2. Enter the desired length of time. Model LREL6325* Use the number buttons. Model LREL6323* / LREL6321* Use the +/- buttons.
3. Press Timer On/Off to start the Timer. The remaining time countdown appears in the display
4. When the timer reaches 0:00, End shows in the display. The clock beeps every 15 seconds until the Timer On/Off button is pressed.

Canceling the Timer

1. Press Timer On/Off once. The display returns to the time of day

Settings

Model LREL6323*: Press and hold Start Time for 3 seconds. Then press the Start Time key repeatedly to toggle through and change oven settings.

Model LREL6325* / LREL6321*: Press the Settings button repeatedly to toggle through and change oven settings.

The Settings key allows you to:

- set the hour mode on the clock (12 or 24 hours)
- enable/disable convection auto conversion (Model LREL6325* / LREL6323*)
- adjust the oven temperature
- activate/deactivate the preheating alarm light
- set the beeper volume
- switch the temperature scale between Fahrenheit and Celsius

Setting the Hour Mode: The control is set to use a 12-hour clock. To reset the clock to 24-hour mode, follow the steps below.

- Model LREL6325*
 1. Press and hold Settings button.
 2. Press 1 to toggle between a 12-hour and 24-hour clock.
 3. Press Start to accept the change.
- Model LREL6323* / LREL6321*
 1. Model LREL6323* Press and hold the Start Time button for 3 seconds. Model LREL6321* Press and hold Settings button.
 2. Press +/- to toggle between a 12-hour and 24- hour clock.

3. Press Start to accept the change.

Setting Convection Auto Conversion (Model LREL6325* / LREL6323*)

- When using convection bake, convection roast the convection auto conversion feature will automatically convert entered regular baking temperatures to convection baking temperatures. When this feature is enabled, the display will show the actual converted temperature.
- For example, if you enter a regular recipe temperature of 350°F and press the START button, the display will show the converted temperature of 325°F.

Model LREL6325*

1. Press Settings repeatedly until Auto appears in the display.
2. Press 1 to switch Auto Conversion on or off. 3 Press Start to accept the change.

Model LREL6323*

1. Press and hold the Start Time button for 3 seconds.
2. Press Start Time repeatedly until Auto appears in the display.
3. Press +/- button to switch Auto Conversion on or off.

Adjusting the Oven Temperature

- Your new oven may cook differently from the one it replaced. Use your new oven for a few weeks to become more familiar with it before changing the temperature settings. If after familiarizing yourself with the new oven, you still think that it is too hot or too cold, you can adjust the oven temperature yourself.
- NOTE: To begin, either raise or lower the thermostat 15 °F (8 °C). Try the oven with the new setting. If the oven still needs adjustment, raise or lower the thermostat again, using the first adjustment as a gauge. For example, if the adjustment was too much, raise or lower the thermostat 10 °F (5 °C). If the adjustment was not enough, raise or lower the thermostat 20 °F (12 °C). Proceed in this way until the oven is adjusted to your satisfaction.

Model LREL6325*

1. Press Settings repeatedly until AdJU appears in the display.
2. Use the number keys to enter the number of degrees you want to adjust the oven temperature. Press Settings again to add a minus sign if decreasing the temperature.
3. Press Start to accept the change.

Model LREL6323* / LREL6321*

1. Model LREL6323* Press and hold the Start Time button for 3 seconds. Press Start Time repeatedly until AdJU appears in the display. Model LREL6321* Press Settings repeatedly until AdJU appears in the display.

2. Set the number of degrees to adjust: Press or press and hold the +/- buttons until the desired number of degrees appears in the display. Press Settings again to add a minus sign if decreasing the temperature.
3. Press Start to accept the change.

Turning the Preheat Alarm Light On/Off: When the oven reaches its set-temperature, the preheating alarm light flashes 5 times or until the oven door is opened. You can activate or deactivate the preheating alarm light.

Model LREL6325*

1. Press Settings repeatedly until PrE appears in the display.
2. Press 1 to turn the light on/off.
3. Press Start to accept the change.

Model LREL6323* / LREL6321*

1. Model LREL6323* Press and hold the Start Time button for 3 seconds. Press Start Time repeatedly until PrE appears in the display. Model LREL6321* Press Settings repeatedly until PrE appears in the display.
2. Press +/- to turn the light on/off.
3. Press Start to accept the change.

Adjusting the Beeper Volume

Model LREL6325*

1. Press Settings repeatedly until Beep appears in the display.
2. Press 1 to select Hi, Lo or Off.
3. Press Start to accept the change.

Model LREL6323*/LREL6321*

1. Model LREL6323* Press and hold the Start Time button for 3 seconds. Press Start Time repeatedly until Beep appears in the display. Model LREL6321* Press Settings repeatedly until Beep appears in the display.
2. Press +/- to select Hi, Lo or Off.
3. Press Start to accept the change.

Selecting Fahrenheit or Celsius: Set the oven temperature display to show either Fahrenheit (°F) or Celsius (°C) units. The oven defaults to Fahrenheit unless changed by the user.



Model LREL6325*

1. Press Settings repeatedly until Unit appears in the display.
2. Press 1 to select F (Fahrenheit) or C (Celsius).
3. Press Start to accept the change.

Model LREL6323* / LREL6321*

1. Model LREL6323* Press and hold the Start Time button for 3 seconds. Press Start Time repeatedly until Unit appears in the display. Model LREL6321* Press Settings repeatedly until Unit appears in the display.
2. Press +/- to select F (Fahrenheit) or C (Celsius).
3. Press Start to accept the change.

Lockout: The Lockout feature automatically locks the oven door and prevents most oven controls from being turned on. It does not disable the timer and the interior oven light.

1. Press and hold Clear/Off for three seconds.
2. The lock melody sounds, Loc appears in the display(available on some models) and the lock  blinks in the display.
3. Once the oven door is locked, the lock  indicator stops blinking and remains on.
4. To deactivate the Lockout feature, press and hold Clear/Off for three seconds. The unlock melody sounds and the door and the controls unlock.

Cook Time (Timed Cook)

Set the oven to cook for a specific length of time using the Timed Cook feature. This feature can only be used with the Bake, Conv. Bake, Conv. Roast, Frozen Meal, Slow Cook and Favorite Cook modes.

Setting the Cook Time Function: For example, to bake at 300 °F for 30 minutes, first set the clock to the correct time of day

Model LREL6325*

1. Press Bake. 350 °F appears in the display.
2. Set the temperature. Press 3, 0 and 0.
3. Press Cook Time. Timed flashes in the display. Bake, 300 °F and 0:00 appear in the display.
4. Set the baking time: Press 3 and 0. The baking time can be set for any amount of time between 1 minute and 11 hours and 59 minutes.
5. Press START.

Model LREL6323* / LREL6321*

1. Press Bake. 350 °F appears in the display.
2. Set the temperature. Press +/- key.
3. Press Cook Time. Timed flashes in the display. Bake, 0:00 appear in the display.

4. Set the baking time: Press +/- key to set the baking time. The baking time can be set for any amount of time between 1 minute and 11 hours and 59 minutes.
5. Press START.

The oven will continue to cook for the set amount of time and then turn off automatically. When the cooking time has elapsed:

- End and the time of day show in the display.
- The cook end indicator tone sounds every 60 seconds until Clear/Off is pressed.
- When Warm is set, the warming function is activated after the cooking time ends.

Changing the Cook Time during Cooking: For example, to change the cook time from 30 minutes to 1 hour and 30 minutes, do the following.

Model LREL6325*

1. Press Cook Time.
2. Change the baking time: Press 1, 3 and 0.
3. Press START to accept the change.

Model LREL6323* / LREL6321*

1. Press Cook Time.
2. Change the baking time: Press +/- button.
3. Press START to accept the change.

Start Time (Delayed Timed Cook)

The automatic timer of the Delayed Timed Cook function turns the oven on and off at the time you select. This feature can be used with the Bake, Conv. Bake, Conv. Roast, Self Clean modes.

Setting a Delayed Timed Cook: For example, to bake at 350 °F and delay the start of baking until 4:30, first set the clock to the correct time of day.

Model LREL6325*

1. Press Bake. 350 °F appears in the display.
2. Set the temperature: touch 3, 5 and 0.
3. Press Start Time and touch the number keys to set the baking time.
4. Press Start Time.
5. Set the start time: press 4, 3 and 0 for 4:30.
6. Press Start. A short beep sounds and Timed Delay appears in the display. The oven begins baking at the set start time.

Model LREL6323* / LREL6321*

1. Press Bake. 350 °F appears in the display.
2. Set the temperature: Press or press and hold the +/- buttons until the desired temperature appears in the display
3. Press Cook Time and touch +/- keys to set the baking time.
4. Press Start.
5. Set the start time: Use the +/- buttons to adjust the time displayed to match your desired start time.
6. Press Start. A short beep sounds and Timed Delay and the start time appear in the display. The oven begins baking at the set start time.

The oven will continue to cook for the set amount of time and then turn off automatically. When the cooking time has elapsed:

- End and the time of day show in the display.
- The cook end indicator tone sounds every 60 seconds until Clear/Off is pressed.
- When Warm is set, the warming function is activated after the cooking time ends.

InstaView™ (Model LREL6325*)

Knock twice on the center of the glass panel to reveal the contents of the oven without opening the door.

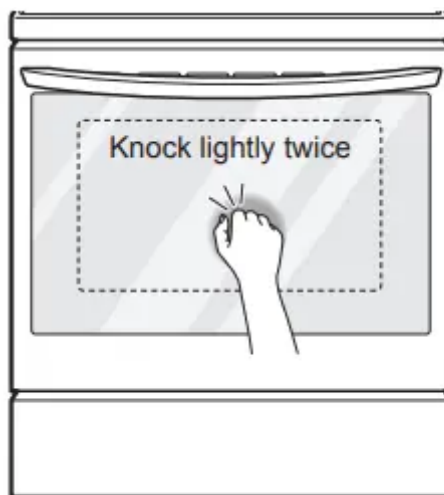

- Knocking twice on the glass panel turns the interior light on or off.
- The light turns off automatically after 90 seconds.
- The InstaView™ function is disabled when the oven door is opened and for one seconds after closing the door.
- The InstaView™ function is disabled during Self Clean, Lockout, and initial power input.

Using the Cooktop

Cooking Areas

- The cooking areas on your range are identified by permanent circles on the glass cooktop surface. For the most efficient cooking, fit the pan size to the element size.
- Pans should not extend more than 1/2 to 1-inch beyond the cooking area.
- When a control is turned on, a glow can be seen through the glass cooktop surface.

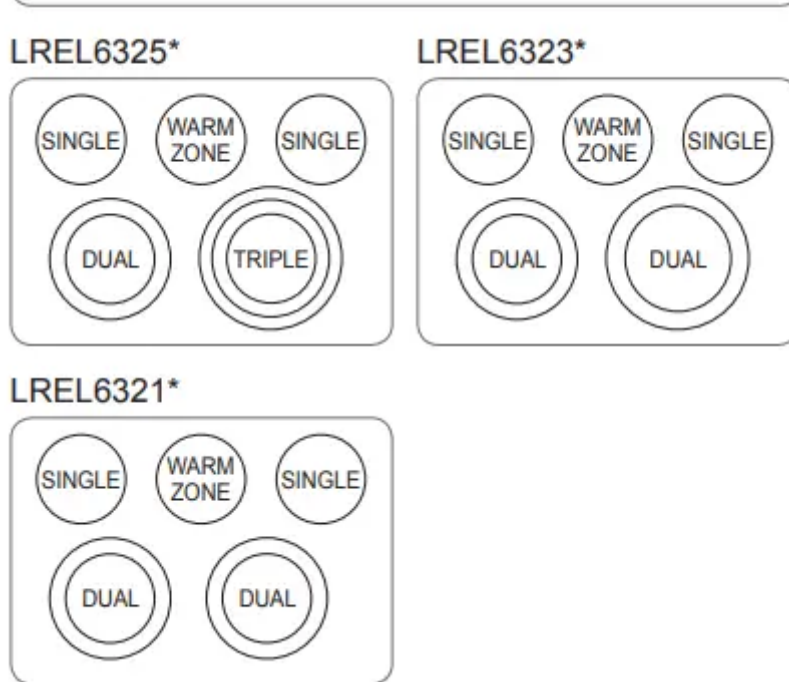

Recommended Element Levels

Setting	Recommended Use
8.5-Hi	<ul style="list-style-type: none"> • Bring liquid to a boil • Start cooking
5.5-8.0	<ul style="list-style-type: none"> • Hold a rapid boil, frying, deep fat fry • Quickly brown or sear food
3.5-5.0	<ul style="list-style-type: none"> • Maintain a slow boil • Fry or saute foods • Cook soups, sauces and gravies
2.2-3.0	<ul style="list-style-type: none"> • Stew or steam food • Simmer
Lo-2.0	<ul style="list-style-type: none"> • Keep food warm • Melt chocolate or butter • Simmer

COOKTOP HOT Indicator

- Once the element is turned off, COOKTOP HOT appears in the display as long as the surface cooking area is too hot to touch.
- It remains on until the surface has cooled to approximately 150 °F

NOTE: During Self Clean (available on some models), COOKTOP HOT remains on.

Using the Cooktop Elements

Turning on a Single Element

1. Push the Single element knob in.
2. Turn the knob in either direction to the desired setting. The control knob clicks when it is positioned at both Off and HI

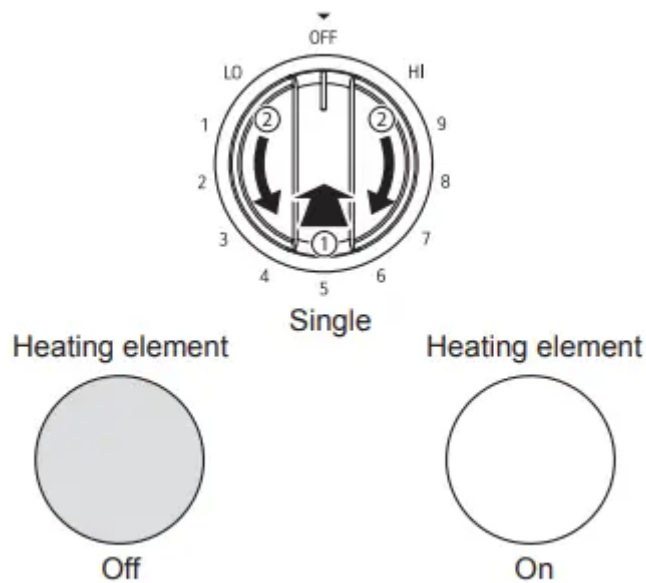

Turning on the Dual Element: There is one dual element located in the left front position. Use the dual element as a dual or single element.

- 1 Push in the appropriate knob.
- 2-A Turn the knob counterclockwise to use it as a Single element.
- 2-B Turn the knob clockwise to use it as a Dual unit.

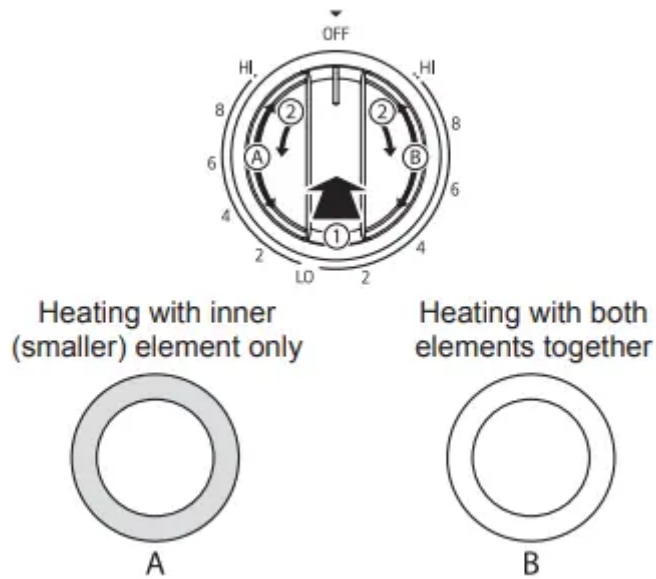

Turning on a Triple Element (on some models): There is one triple element that can be used as either a single, dual or triple element.

1 Push in the appropriate knob.

2-A Turn the knob counterclockwise to use the Single element.

2-B Turn the knob clockwise to the Dual position to use as a Dual element.

2-C Turn the knob clockwise to the Triple position to use as a Triple element.

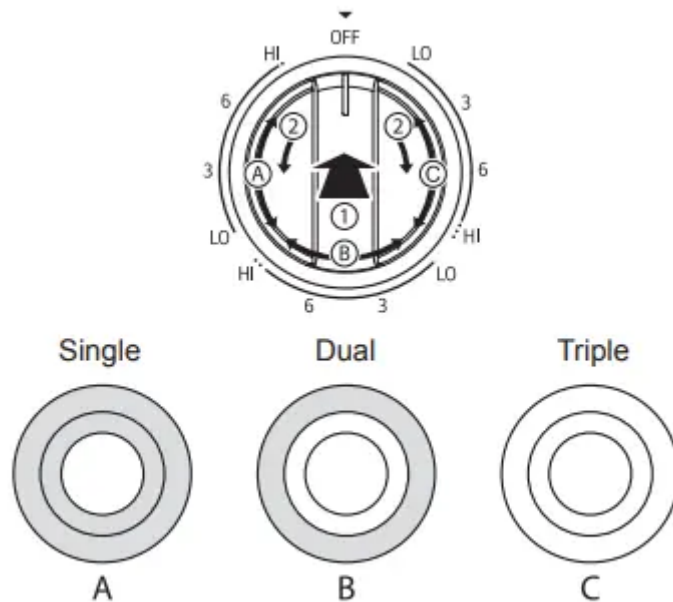

Turning on the Warming Zone: The Warming Zone, located in the back center of the glass surface, will keep hot, cooked food at serving temperature. Use the Warming Zone to keep food warm after

it has already been cooked. Attempting to cook uncooked or cold food on the Warming Zone could result in a food-borne illness.

1. Press the COOKTOP Set/Off button. The warming zone indicator light flashes.
2. Model LREL6325* Use the Level buttons to adjust the temperature settings. The temperature settings are adjustable at all times. Model LREL6323* / LREL6321* Use the – / + buttons to adjust the temperature settings. The temperature settings are adjustable at all times.
3. To turn off the warming zone, press the Set/Off button once.

Using the Proper Cookware

- The size and type of cookware will influence the settings needed for the best cooking results. Be sure to follow the recommendations for using proper cookware.

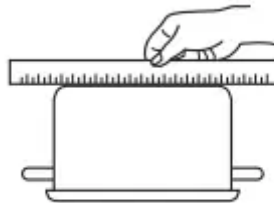

- Cookware should have flat bottoms that make good contact with the entire surface heating element. Check for flatness by placing a ruler across the bottom of the cookware. The ruler should touch the cookware across the entire bottom, with no gaps.
- Cookware recommendations
 - Flat bottom and straight sides
 - Heavy-gauge pans
 - Pan sizes that match the amount of food to be prepared and the size of the surface element
 - Weight of handle does not tilt pan.
 - Pan is well balanced
 - Tight-fitting lids
 - Flat bottom woks

Cookware should not

- have a curved or warped bottom.

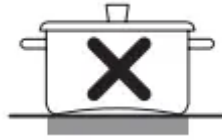

- be smaller or larger than the surface burner.



- have a heavy handle that tilts the pan.



- be a wok with a ring stand.



- have loose or broken handles.
- have loose-fitting lids.

Choosing Cookware: The cookware material determines how evenly and quickly heat is transferred from the surface element to the pan bottom. The most popular materials available are:

- Aluminum - Excellent heat conductor. Some types of food will cause it to darken (anodized aluminum cookware resists staining and pitting). If aluminum pans slide across the ceramic cooktop, they may leave metal marks which will resemble scratches. Remove these marks immediately.
- Copper - Excellent heat conductor but discolors easily. May leave metal marks on glass-ceramic (see Aluminum above).
- Stainless steel - Slow heat conductor with uneven cooking results. Is durable, easy to clean and resists staining.
- Cast iron - A poor heat conductor but retains heat very well. Cooks evenly once cooking temperature is reached. Not recommended for use on ceramic cooktops.
- Porcelain-enamel on metal - Heating characteristics will vary depending on base material. Porcelain-enamel coating must be smooth to avoid scratching ceramic cooktops.

- Glass - Slow heat conductor. Not recommended for ceramic cooktop surfaces because it may scratch the glass.

Home Canning Tips: Be sure that the canner is centered over the surface element and is flat on the bottom.

- The base must not be more than 1 inch larger than the element. Use of water bath canners with rippled bottoms may extend the time required to bring the water to a boil and may damage the cooktop.
- Some canners are designed with smaller bases for use on smooth surfaces.
- Use the high heat setting only until the water comes to a boil or pressure is reached in the canner.
- Reduce to the lowest heat setting that maintains the boil, or pressure. If the heat is not turned down, the cooktop may be damaged.

Using the Oven

Before Using the Oven

Oven Vent

- Areas near the vent may become hot during operation and may cause burns. Do not block the vent opening.
- Avoid placing plastics near the vent as heat may distort or melt the plastic. It is normal for steam to be visible when cooking foods with high moisture content.

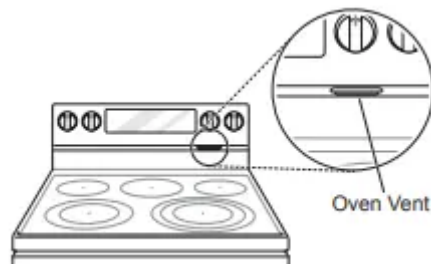

Using Oven Racks: The racks have a turned-up back edge that prevents them from being pulled out of the oven cavity.



Removing Racks

1. Pull the rack straight out until it stops.



2. Lift up the front of the rack and pull it out.

Replacing Racks

1. Place the end of the rack on the support.
2. Tilt the front end up and push the rack in.

SMART FUNCTIONS

LG ThinQ Application

- This feature is only available on models with the  or  logo .
- The LG ThinQ application allows you to communicate with the appliance using a smartphone.

LG ThinQ Application Features

- Smart Diagnosis™: This function provides useful information for diagnosing and solving issues with the appliance based on the pattern of use.
- Settings: Allows you to set various options on the oven and in the application.
- Monitoring: This function shows the current status, remaining cook time, and cook settings on one screen.
- Push Alerts: Turn on the Push Alerts to receive appliance status notifications. The notifications are triggered even if the LG ThinQ application is off.
- Timer: You can set the timer from the app.
- Firmware Update: Keep the appliance updated.
- Remote Start: Control the appliance remotely or check the remaining cook time from the LG ThinQ application.

Before Using LG ThinQ Application

- 1 Use a smartphone to check the strength of the wireless router (Wi-Fi network) near the appliance.
 - If the distance between the appliance and the wireless router is too far, the signal becomes weak. It takes long time to register or fails to install the application.
- 2 Turn off the Mobile data or Cellular Data on your smartphone.

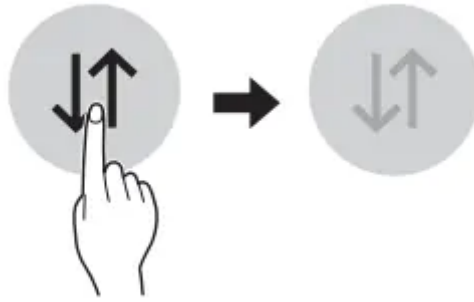

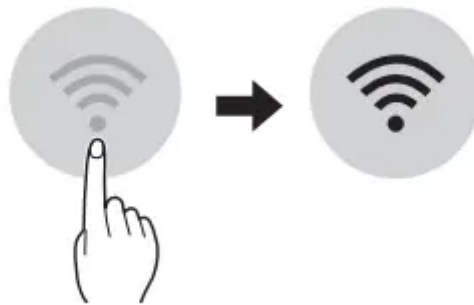

3 Connect your smartphone to the wireless router.



Installing the LG ThinQ Application

- Search for the LG ThinQ application from the Google Play Store or Apple App Store on a smartphone. Follow instructions to download and install the application.

Smart Diagnosis™ Feature

- This feature is only available on models with the  or  icon.
- Use this feature to help you diagnose and solve problems with your appliance.

Using LG ThinQ to Diagnose Issues

If you experience a problem with your Wi-Fi equipped appliance, it can transmit troubleshooting data to a smartphone using the LG ThinQ application.

- Launch the LG ThinQ application and select the Smart Diagnosis feature in the menu. Follow the instructions provided in the LG ThinQ application.

Using Audible Diagnosis to Diagnose Issues

Follow the instructions below to use the audible diagnosis method.

- Launch the LG ThinQ application and select the Smart Diagnosis feature in the menu.

Follow the instructions for audible diagnosis provided in the LG ThinQ application.

1. Open the LG ThinQ application on the smart phone.

2. In the application, select the appliance from your list of connected appliances and then press the dots at the upper right of the screen.
3. Select Smart Diagnosis, then press the Start Smart Diagnosis button.
4. Select the Audible Diagnosis.
5. Follow the instructions on the smart phone.
6. Keep the phone in place until the tone transmission has finished. View the diagnosis on the phone



MAINTENANCE

Cleaning the Glass-Ceramic Cooktop

CAUTION

- Do not use scrub pads or abrasive cleaning pads. They may damage your cooktop surface.
- For your safety, wear an oven mitt or pot holder while using a scraper on the hot cooking surface.

Use ceramic cooktop cleaner on the glass cooktop. Other creams may not be as effective or may scratch, damage or stain the cooktop surface.

To maintain and protect the surface of the glass cooktop, follow these steps:

1. Before using the cooktop for the first time, clean it with a ceramic cooktop cleaner. This helps protect the top and makes cleanup easier.
2. Use ceramic cooktop cleaner daily to help keep the cooktop looking new.
3. Shake the cleaning cream well. Apply a few drops of cleaner directly to the cooktop.
4. Use a paper towel to clean the entire cooktop surface.
5. Rinse with clean water and use a dry cloth or paper towel to remove all cleaning residue

NOTE: Do not heat the cooktop until it has been cleaned thoroughly

IMPORTANT

- If sugar or food containing sugar spills, or plastic or foil melts on the cooktop, remove the material IMMEDIATELY with a metal razor scraper while the cooking surface is still hot to avoid the risk of damage to the glass-ceramic surface. When used correctly, the scraper will not damage the cooktop surface. For your safety, please use an oven mitt or pot holder while scraping the hot cooking surface.
- If water or food containing water spills on the cooktop, remove the spill IMMEDIATELY with a dry paper towel.

NOTE: ANY DAMAGE OR FAILURE OF THE PRODUCT RESULTING FROM 1 OR 2 BELOW MAY NOT BE COVERED UNDER THE LIMITED WARRANTY.

1. Sugary spillovers (such as preserves, ketchup, tomato sauce, jellies, fudge, candy, syrups, or chocolate) or melted plastics can cause pitting on the surface of your cooktop.
2. If food or water containing calcium (such as baking powder, wine, milk, spinach, or broccoli) is spilled on the cooktop, it can permanently stain or discolor the surface.

Burned-On Residue

1 While the cooktop is still warm, remove any burnt on deposits or spilled food from the glassceramic cooking surface with a suitable metal razor scraper. To prevent burns, wear an oven mitt or pot holder while using the metal scraper.

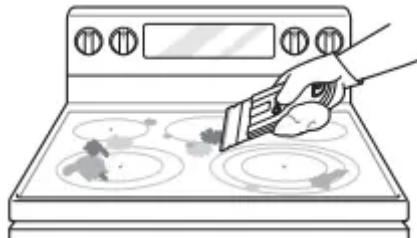

NOTE

- Do not use a dull or nicked blade.
 - Hold the scraper at approximately a 30° angle to the cooktop.
 - The razor scraper will not damage the markings on the cooking surface
- 2 When the cooking surface has completely cooled, apply a few dime-sized dabs of a ceramic glass cooktop cleaner in each burner area. Work the cleaning cream over the cooktop surface with a damp paper towel. Leave the cleaner on for 10 minutes before rinsing it off.



3 Rinse with clean water and wipe the cooktop surface with a clean, dry paper towel.

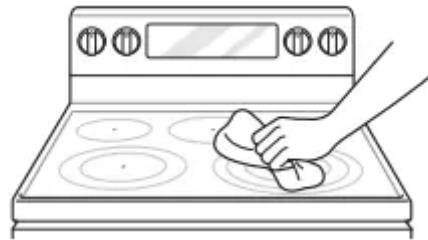

Maintaining the Cooktop

- DO NOT use chlorine bleach, ammonia, or other cleaners not specifically recommended for use on glass-ceramic cooktops.
- Let your glass-ceramic cooking surface cool off before cleaning.

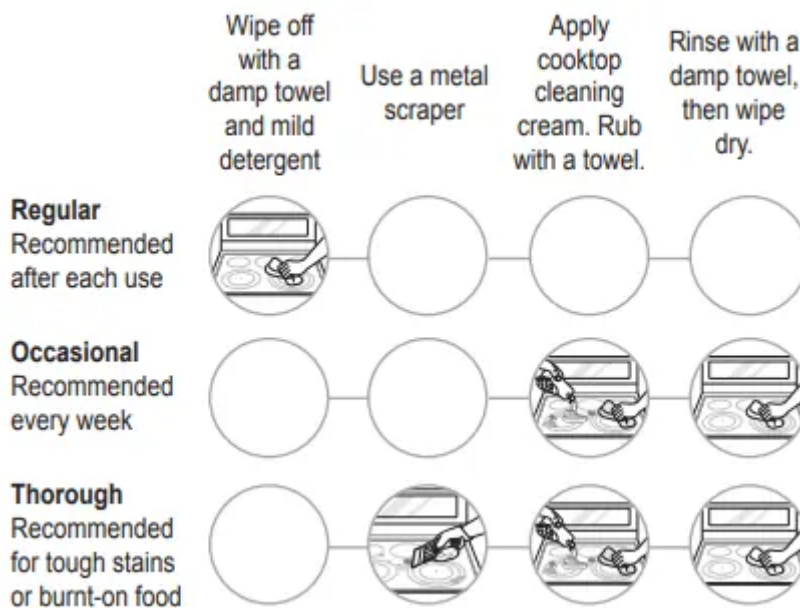

- For additional product information, visit our website at lg.com

Metal Marks and Scratches

ANY DAMAGE OR FAILURE OF THE PRODUCT RESULTING FROM 1 OR 2 BELOW MAY NOT BE COVERED UNDER THE LIMITED WARRANTY.

1. Be careful not to slide pots and pans across the cooktop. Doing so will leave metal markings on the cooktop surface. To help remove these marks, use a ceramic cooktop cleaner with a cleaning pad for ceramic cooktops. Scratches from sliding cookware are permanent and are not covered by the warranty.
2. If pots with a thin overlay of aluminum or copper are allowed to boil dry, the overlay may leave a black discoloration on the cooktop. This should be removed immediately before heating again or the discoloration may be permanent. This damage is not covered by the warranty

CAUTION: Cookware with rough or uneven bottoms can mark or scratch the cooktop surface.

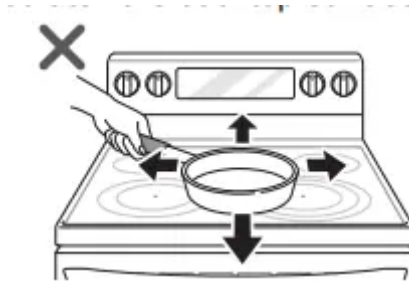

- Do not slide metal or glass across the cooktop surface.
- Do not use cookware with any dirt build-up on the bottom.
- Do not use cookware if there are foreign matters on the cooktop surface. Always clean the cooktop surface before cooking.

EasyClean®

- LG's EasyClean® enamel technology provides two cleaning options for the inside of the range. The EasyClean® feature takes advantage of LG's new enamel to help lift soils without harsh chemicals, and it runs using ONLY WATER for just 10 minutes in low temperatures to help loosen LIGHT soils before hand-cleaning.
- While EasyClean® is quick and effective for small and LIGHT soils, the Self Clean feature can be used to remove HEAVY, built up soils. The intensity and high heat of the Self Clean cycle may result in smoke which will require the opening up of windows to provide ventilation. Compared to the more intense Self Clean process, your LG oven gives you the option of cleaning with LESS HEAT, LESS TIME, and virtually NO SMOKE OR FUMES.
- When needed, the range still provides the Self Clean option for longer, more thorough oven cleaning for heavier, built up soils.

Benefits of EasyClean®

- Helps loosen light soils before hand-cleaning
- EasyClean® only uses water; no chemical cleaners
- Makes for a better self-clean experience
 - Delays the need for a self-clean cycle
 - Minimizes smoke and odors
 - Can allow shorter self-clean time

NOTE: Some models don't include a self-clean option. The EasyClean® feature may not be effective in removing heavy, built-up soils. If the range does not include a self-clean option, clean the oven regularly using the EasyClean® feature to prevent heavy, burnt-on soil from building up in the oven.

When to Use EasyClean®

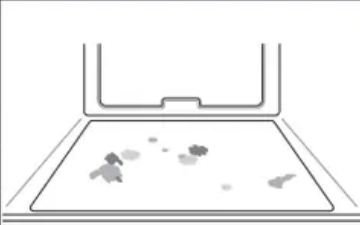
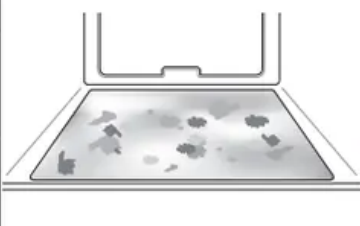
Suggested Cleaning Method	Example of Oven Soiling	Soil Pattern	Types of Soils	Common Food Items That Can Soil Your Oven
EasyClean®		Small drops or spots	Cheese or other ingredients	Pizza
		Light splatter	Fat/grease	Steaks, broiled
				Fish, broiled
Meat roasted at low temperatures				
Self Clean*		Medium to heavy splatter	Fat/grease	Meat roasted at high temperatures
		Drops or spots	Filling or sugar based soils	Pies
			Cream or tomato sauce	Casseroles

* The Self Clean cycle can be used for soil that has been built up over time.

On models without the self-clean option, clean the oven frequently using EasyClean® to avoid the build up of tough, burnt-on soil.

Cleaning Tips

- Allow the oven to cool to room temperature before using the EasyClean® cycle. If your oven cavity is above 150 °F (65 °C), Hot will appear in the display, and the EasyClean® cycle will not be activated until the oven cavity cools down.
- A scraper can be used to scrape off any chunks or debris before and during oven cleaning.

- Using the rough side of a non-scratch scouring pad or scrubbing sponge may help to take off burnt-on stains better than a soft sponge or towel.
- Certain non-scratch scrubbing sponges, such as those made of melamine foam, available at your local stores, can also help improve cleaning.
- The range should be level to ensure that the bottom surface of the oven cavity is entirely covered by water at the beginning of the EasyClean® cycle.
- For best results, use distilled or filtered water. Tap water may leave mineral deposits on the oven bottom.
- Soil baked on through several cooking cycles will be more difficult to remove with the EasyClean® cycle.
- Do not open the oven door during the EasyClean® cycle. Water will not get hot enough if the door is opened during the cycle.
- For hard to reach areas such as the back surface it is better to use the Self Clean cycle.

EasyClean® Instruction Guide

1. Remove oven racks and accessories from the oven.
2. Scrape off and remove any burnt-on debris with a plastic scraper. Suggested plastic

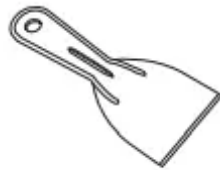

scrapers:

- Hard plastic spatula
 - Plastic pan scraper
 - Plastic paint scraper
 - Old credit card
3. Fill a spray bottle with water (10 oz or 300 ml) and use the spray bottle to thoroughly spray the inside surfaces of the oven.

4. Use at least 1/5 (2 oz or 60 ml) of the water in the bottle to completely saturate the soil on both the walls and in the corners of the oven

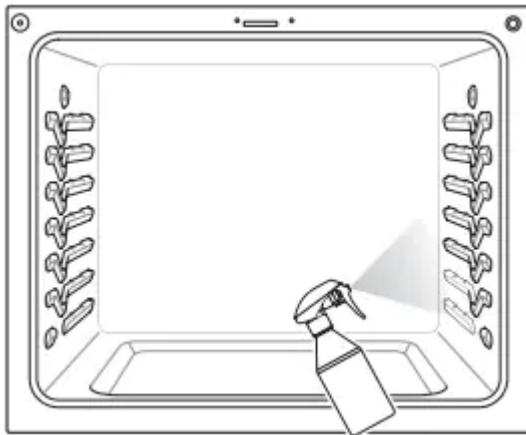

5. Spray or pour the remaining water (8 oz or 250 ml) onto the bottom center of the oven cavity. The indentation on the oven bottom should be fully covered to submerge all soils. Add water if necessary. NOTE: If cleaning multiple ovens, use an entire bottle of water to clean each oven. Do not spray water directly on the door. Doing so will result in water (10 oz or 300 ml) dripping to the floor.

6. Close the oven door. Press EasyClean®. Press Start. CAUTION

- Some surfaces may be hot after the EasyClean® cycle. Wear rubber gloves while cleaning to prevent burns.
- During the EasyClean® cycle, the oven becomes hot enough to cause burns. Wait until the cycle is over before wiping the inside surface of the oven. Failure to do so may result in burns.
- Avoid leaning or resting on the oven door glass while cleaning the oven cavity.

7. A tone will sound at the end of the 10 minute cycle. Press Clear/Off to clear the display and end the tone.

8. After the cleaning cycle and during handcleaning, enough water should remain on the oven bottom to completely submerge all soils. Add water if necessary. Place a towel on the floor in front of the oven to capture any water that may spill out during hand-cleaning.

9. Clean the oven cavity immediately after the EasyClean® cycle by scrubbing with a wet, non-scratch scouring sponge or pad. (The scouring side will not scratch the finish.)



NOTE Do not use any steel scouring pads, abrasive pads or cleaners as these materials can permanently damage the oven surface.

10. Once the oven cavity is cleaned, wipe any excess water with a clean dry towel. Replace racks and any other accessories.

11. If some light soils remain, repeat the above steps, making sure to thoroughly soak the soiled areas. If stubborn soils remain after multiple EasyClean® cycles, run the Self Clean cycle. Be sure that the oven cavity is empty of oven racks and other accessories, and that the oven cavity surface is dry before running the Self Clean cycle. Consult the Self Clean section of your owner's manual for further details. If a self-clean option is not available, scrape off and remove stubborn soil using a scraper.

NOTE

- If you forget to saturate the inside of the oven with water before starting EasyClean®, press Clear/ Off to end the cycle. Wait for the range to cool to room temperature and then spray or pour water (10 oz or 300 ml) into the oven and start another EasyClean® cycle.
- The cavity gasket may be wet when the EasyClean® cycle finishes. This is normal. Do not clean the gasket.
- If mineral deposits remain on the oven bottom after cleaning, use a cloth or sponge soaked in vinegar to remove them.
- It is normal for the fan to operate during the EasyClean® cycle.

Self Clean (Model LREL6325* / LREL6323*)

- The Self Clean cycle uses extremely hot temperatures to clean the oven cavity. While running the Self Clean cycle, you may notice smoking or an odor. This is normal; especially if the oven is heavily soiled.
- During Self Clean, the kitchen should be well ventilated to minimize the odors from cleaning.

Before Starting Self Clean

- Remove the oven racks, broiler pan, broiler grid, all cookware, aluminum foil or any other material from the oven.
- The kitchen should be well ventilated to minimize the odors from cleaning.
- Wipe any heavy spillovers on the bottom of the oven.
- Make sure that the oven light bulb cover is in place and the oven light is off.
- The oven light cannot be turned on during a Self Clean cycle. The oven light cannot be turned on until the oven temperature has cooled below 500 °F (260 °C) after a Self Clean cycle is complete.

CAUTION

- Do not leave small children unattended near the appliance. During the Self Clean cycle, the outside of the range can become very hot to the touch.

- If you have pet birds, move them to another well-ventilated room. The health of some birds is extremely sensitive to the fumes given off during the Self Clean cycle of any range.
- Do not line the oven walls, racks, bottom or any other part of the range with aluminum foil or any other material. Doing so will destroy heat distribution, produce poor baking results and cause permanent damage to the oven interior (aluminum foil will melt to the interior surface of the oven).
- Do not force the door open. This can damage the automatic door locking system. Use care when opening the oven door after the Self Clean cycle. Stand to the side of the oven when opening the door to allow hot air or steam to escape. The oven may still be VERY HOT.

During the Self Clean cycle, the cooktop elements cannot be used.

NOTE

- Remove oven racks and accessories before starting the Self Clean cycle.
- If oven racks are left in the oven cavity during the Self Clean cycle, they will discolor and become difficult to slide in and out. • Clean the frame of the oven and door with hot soapy water. Rinse well.
- Do not clean the gasket. The fiberglass material of the oven door gasket cannot withstand abrasion. It is essential for the gasket to remain intact. If you notice it becoming worn or frayed, replace it.
- Wipe up any heavy spillovers on the oven bottom.
- Make sure that the oven light bulb cover is in place and the oven light is off.
- If the cooktop is used during Self Clean operation, a buzzer will sound for 1 minute and then Self Clean will turn off.
- If the cooktop is in use when a Self Clean is activated, a buzzer will sound and Self Clean will not start.

Setting Self Clean: The Self Clean function has cycle times of 4, 5 or 3 hours.

Self Clean Soil Guide

Soil Level	Cycle Setting
Lightly Soiled Oven Cavity	3-Hour Self Clean
Moderately Soiled Oven Cavity	4-Hour Self Clean
Heavily Soiled Oven Cavity	5-Hour Self Clean

1. Remove all racks and accessories from the oven.

2. Press Self Clean. The oven defaults to the recommended four-hour self clean for a moderately soiled oven. Press twice for a five-hour self clean or three times for a three-hour self clean.
3. Press Start.
4. Once the self-clean cycle is set, the oven door locks automatically and the lock icon displays. You will not be able to open the oven door until the oven has cooled. The lock releases automatically when the oven has cooled.

CAUTION: Do not force the oven door open when the lock icon is displayed. The oven door remains locked until the oven temperature has cooled. Forcing the door open will damage the door.

Setting Self Clean with a Delayed Start

1. Remove all racks and accessories from the oven.
2. Press the Self Clean button. The oven defaults to the recommended four-hour self clean for a moderately soiled oven. Press Self Clean button to set the time.
3. Press Start Time.
4. Model LREL6325* Use the number buttons to enter the time of day you would like the Self Clean to start. Model LREL6323* Press the +/- buttons until the display shows the time of day you would like the Self Clean to start.
5. Press Start.

NOTE: It may become necessary to cancel or interrupt a Self Clean cycle due to excessive smoke or fire in the oven. To cancel the Self Clean function, press the CLEAR/OFF button.

During Self Clean

- The Self Clean cycle uses extremely hot temperatures to clean the oven cavity. While running the Self Clean cycle, you may notice smoking or an odor. This is normal, especially if the oven is heavily soiled.
- As the oven heats, you may hear sounds of metal parts expanding and contracting. This is normal and will not damage the oven.
- Do not force the oven door open when the lock is displayed. The oven door remains locked until the oven temperature has cooled. Forcing the door open will damage the door.

After the Self Clean Cycle

- The oven door remains locked until the oven temperature has cooled.
- You may notice some white ash in the oven. Wipe it off with a damp cloth or a soap-filled steel wool pad after the oven cools. If the oven is not clean after one self-clean cycle, repeat the cycle.

- If oven racks were left in the oven and do not slide smoothly after a self-clean cycle, wipe racks and rack supports with a small amount of vegetable oil to make them glide more easily.
- Fine lines may appear in the porcelain because it went through heating and cooling. This is normal and will not affect performance.

NOTE

- The Self Clean cycle cannot be started if the Lockout feature is active.
- Once the Self Clean cycle is set, the oven door locks automatically. You will not be able to open the oven door until the oven is cooled. The lock releases automatically.
- Once the door has been locked, the lock  indicator light stops flashing and remains on. Allow about 15 seconds for the oven door lock to activate.
- If the clock is set for a 12-hour display (default) the Delayed Self Clean can never be set to start more than 12 hours in advance.

Changing the Oven Light

The oven light is a standard 40-watt appliance bulb. It turns on when the oven door is open. When the oven door is closed, press Light to turn it on or off.

1. Unplug the range or disconnect power.
2. Turn the glass bulb cover in the back of the oven counterclockwise to remove.
3. Pull the bulb out of the socket.
4. Insert a new bulb into the socket.
5. Insert the glass bulb cover and turn it clockwise.
6. Plug in the range or reconnect the power.

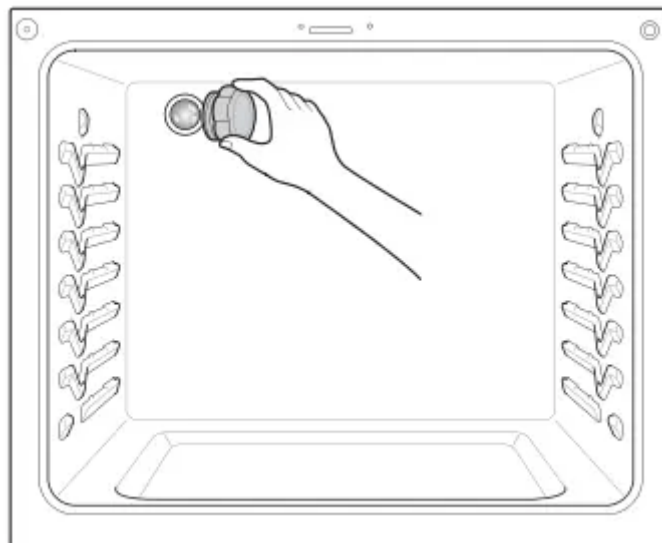

WARNING

- Make sure that the oven and bulb are cool.
- Disconnect the electrical power to the range at the main fuse or circuit breaker panel. Failure to do so can result in severe personal injury, death, or electrical shock.

Cleaning the Exterior

Painted and Decorative Trim

- For general cleaning, use a cloth with hot soapy water. For more difficult soil and built-up grease, apply a liquid detergent directly onto the soil. Leave it on for 30 to 60 minutes. Rinse with a damp cloth and dry. Do not use abrasive cleaners.
- NOTE: When spraying on the glass surface, intermittent touch operation is possible.

Stainless Steel Surfaces: To avoid scratches, do not use steel wool pads.

1. Place a small amount of stainless steel appliance cleaner or polish on a damp cloth or paper towel.
2. Clean a small area, rubbing with the grain of the stainless steel if applicable.
3. Dry and buff with a clean, dry paper towel or soft cloth.
4. Repeat as necessary

NOTE: To prevent scratching, do not use abrasive cleaners on any of these materials.

NOTE

- Do not use a steel wool pad. it will scratch the surface.
- To clean the stainless steel surface, use warm sudsy water or a stainless steel cleaner or polish.
- Always wipe in the direction of the metal surface finish.
- Stainless steel appliance cleaner or polish can be purchased online or from most retailers of appliances or home goods.

Oven Door

- Use soapy water to thoroughly clean the oven door. Rinse well. Do not immerse the door in water.
- You may use a glass cleaner on the outside glass of the oven door. Do not spray water or glass cleaner on the door vents.
- Do not use oven cleaners, cleaning powders, or harsh abrasive cleaning materials on the outside of the oven door.
- Do not clean the oven door gasket. The oven door gasket is made of a woven material that is essential for a good seal. Care should be taken not to rub, damage, or remove this gasket

CAUTION: Do not use harsh cleaners or harsh abrasive cleaning materials on the outside of the oven door. Doing so can cause damage.

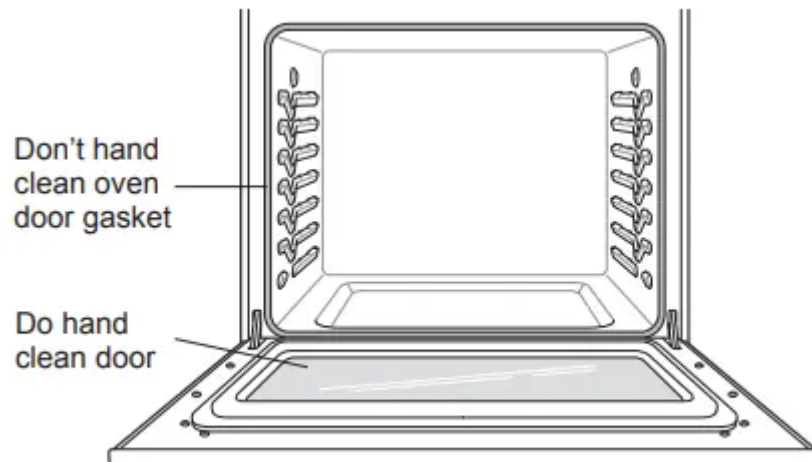

Cleaning the Knobs

- For general cleaning, use a cloth with hot soapy water. For more difficult soil and built-up grease, wipe gently with a brush such as a toothbrush.
- Do not use abrasive cleaners.

Broiler Pan and Grid

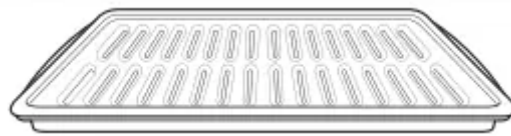

- Do not store a soiled broiler pan or grid anywhere in the range.
- Do not clean the broiler pan or grid in a self-cleaning mode.
- Remove the grid from the pan. Carefully pour out the grease from the pan into a proper container.
- Wash and rinse the broiler pan and grid in hot water with a soap-filled or plastic scouring pad.
- If food has burned on, sprinkle the grid with cleaner while hot and cover with wet paper towels or a dishcloth. Soaking the pan will remove burned-on foods.
- Both the broiler pan and grid may be cleaned with a commercial oven cleaner or in the dishwasher.

Oven Racks: Remove the oven racks before operating the self clean cycle.

1. Food spilled into the tracks could cause the racks to become stuck. Clean racks with a mild, abrasive cleaner.
2. Rinse with clean water and dry

NOTE: If the racks are cleaned using the self clean cycle (not recommended), the color will turn slightly blue and the finish will become dull. After the self clean cycle is complete, and the oven has cooled, rub the sides of the racks with wax paper or a cloth containing a small amount of vegetable oil. This will make the racks glide more easily into the rack tracks.

Door Care Instructions

Most oven doors contain glass that can break.

CAUTION

- Do not close the oven door until all the oven racks are fully in place.
- Do not hit the glass with pots, pans, or any other object.
- Scratching, hitting, jarring, or stressing the glass may weaken its structure causing an increased risk of breakage at a later time.

Removing and Replacing the Lift-Off Oven Doors and Drawer

CAUTION

- Be careful when removing and lifting the door.
- Do not lift the door by the handle. The door is very heavy.

Removing the Door

1. Fully open the door.
2. Unlock the hinge locks, rotating them as far toward the open door frame as they will go.

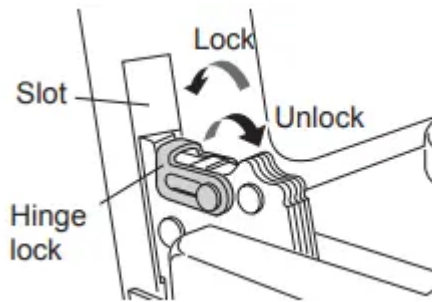

3. Firmly grasp both sides of the door at the top.
4. Close the door to the removal position (approximately five degrees) which is halfway between the broil stop position and fully closed. If the position is correct, the hinge arms will move freely

5. Lift door up and out until the hinge arms are clear of the slots.

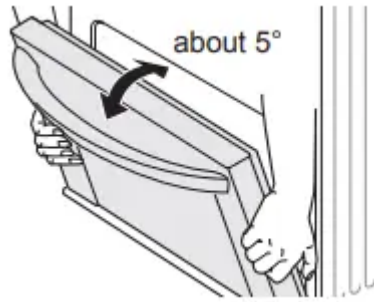

Replacing the Door

1 Firmly grasp both sides of the door at the top.

2 With the door at the same angle as the removal position, seat the indentation of the hinge arms into the bottom edge of the hinge slots. The notch in the hinge arms must be fully seated into the bottom edge of the slots.

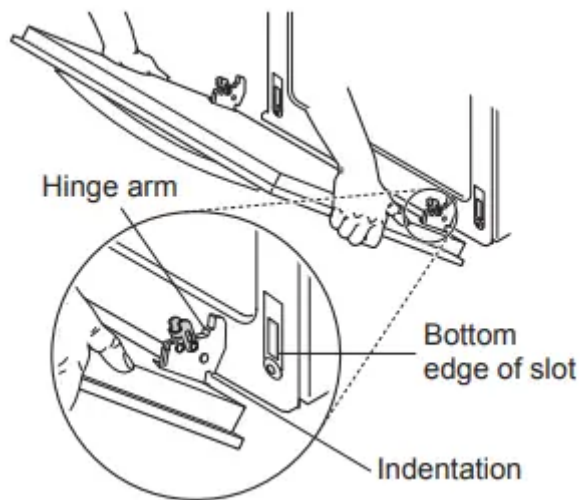

3 Open the door fully. If the door will not open fully, the indentation is not seated correctly in the bottom edge of the slots.

4 Lock the hinge locks, rotating them back toward the slots in the oven frame until they lock.

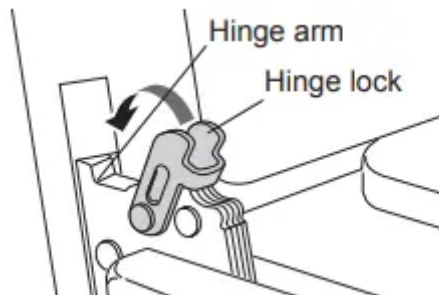

5 Close the oven door.

Removing the Drawer

CAUTION: Disconnect the electrical power to the range at the main fuse or circuit breaker panel. Failure to do so can result in severe personal injury, death, or electrical shock.

Most cleaning can be done with the drawer in place; however, the drawer may be removed if further cleaning is needed. Use warm water to thoroughly clean.

1 Pull the drawer out until it stops.

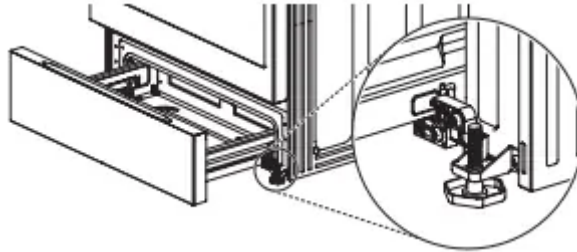

2 Model LREL6325* Unscrew the 2 screws on the back of the drawer.

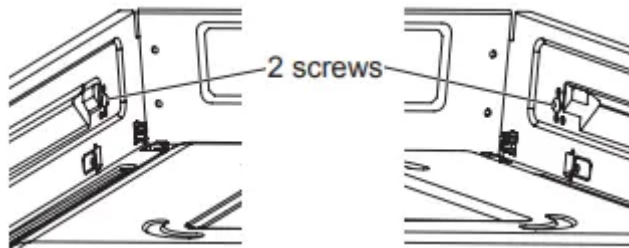

3 Lift the front of the drawer until the stops clear the guides.

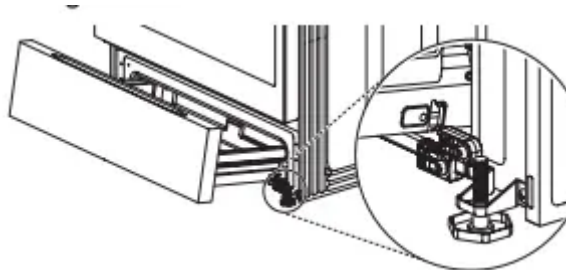

4 Remove the drawer.

Replacing the Drawer

1 Place the drawer rails on the guides.

2 Push the drawer back until it stops.

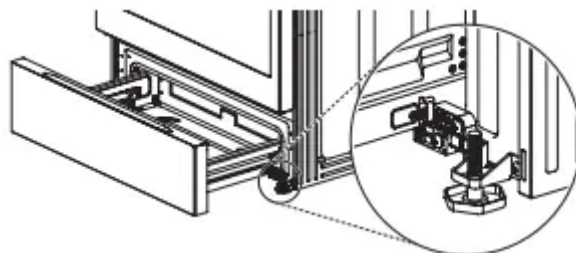

3 Lift the front of the drawer and push back until the stops clear the guides.

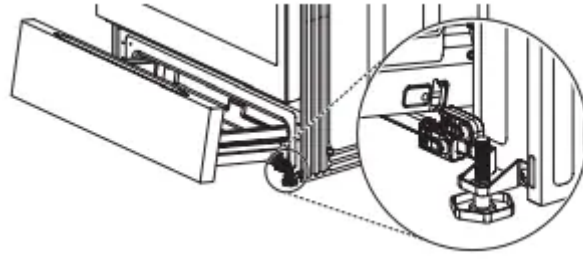

4 Model LREL6325* Screw the 2 screws on the back of the drawer

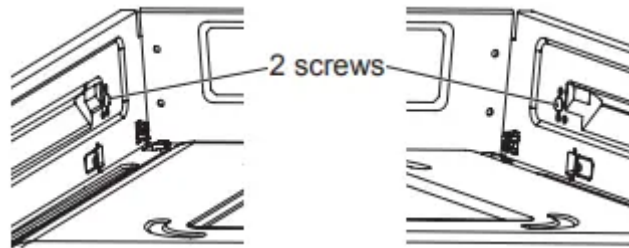

5 Lower the front of the drawer and push back until it closes.

TROUBLESHOOTING

FAQs

1. What types of cookware are recommended for use with the cooktop?

- The pans must have a flat bottom and straight sides.
- Only use heavy-gauge pans.
- The pan size must match the amount of food to be prepared and the size of the surface element.
- Use tight fitting lids.
- Only use flat-bottom woks.

2. Why does “COOKTOP HOT” appear on the cooktop display?

- COOKTOP HOT will appear in the display once the element is turned off or during the self clean cycle. The COOKTOP HOT indicator will stay on until the surface has cooled to approximately 150°F (66°C) or when the self clean cycle ends.

3. Why do the heating elements appear to be turning ON and OFF during use of the cooktop or oven?

- Depending on your cooktop element setting or the temperature selected in your oven, it is NORMAL for the cooking elements to cycle on and off.

4. My new oven doesn't cook like my old one. Is there something wrong with the temperature settings?

- No, your oven has been factory tested and calibrated. For the first few uses, follow your recipe times and temperatures carefully. If you still think your new oven is too hot or too cold, you can adjust the oven temperature yourself to meet your specific cooking needs. Refer to the Oven Temperature Adjustment section in this manual for easy instructions on how to adjust your thermostat.

5. Is it normal to hear a clicking noise coming from the back of my oven when I am using it?

- Your new range is designed to maintain a tighter control over your oven's temperature. You may hear your oven's heating elements click on and off more frequently on your new oven. This is NORMAL.

6. Why is the time flashing?

- This means that the product has just been plugged in, or that it has experienced a power interruption. To clear the flashing time, press any button and reset the clock if needed.

7. During convection cooking the fan stops when I open the door. Is that normal?

- Yes, this is normal. When the door is opened, the convection fan will stop until the door is closed.

8. Can I use aluminum foil to catch drippings in my oven cavity?

- Never use aluminum foil to line the bottom or sides of the oven or the warming drawer. The foil will melt and stick to the bottom surface of the oven and will not be removable. Use a sheet pan placed on a lower oven rack to catch drippings instead. (If foil has already melted onto the bottom of the oven, it will not interfere with the oven's performance.)

9. Can I use aluminum foil on the racks?

- Do not cover racks with aluminum foil. Covering entire racks with foil restricts air flow, leading to poor cooking results. Use a sheet pan lined with foil under fruit pies or other acidic or sugary foods to prevent spillovers from damaging the oven finish.

CAUTION: Foil may be used to wrap food in the oven or warming drawer, but do not allow the foil to come into contact with the exposed heating/broiling elements in the oven. The foil could melt or ignite, causing smoke, fire, or injury

10. Can I leave my racks in the oven when running a Self Clean cycle?

- No. Although it will not damage the racks, it will discolor them and may make them hard to slide in and out during use. Remove all items from the oven before starting a Self Clean cycle.

11. What should I do if my racks are sticky and have become hard to slide in and out?

- Over time, the racks may become hard to slide in and out. Apply a small amount of olive oil to the ends of the racks. This will work as a lubricant for easier gliding.

12. What should I do for hard to remove stains on my cooktop?

- The cooktop should be cleaned after every use to prevent permanent staining. When cooking foods with high sugar content, such as tomato sauce, clean the stain off with a scraper while the cooktop is still warm. Use an oven mitt when scraping to prevent burns. Refer to the MAINTENANCE section of this owner's manual for further instruction.

13. Why aren't the function buttons working?

- Make sure that the range is not in Lockout mode. The lock  will show in the display if Lockout is activated. To deactivate Lockout, press and hold Clear/Off for three seconds. The unlock melody sounds and Loc appears in the display until the controls are unlocked.

14. How can I help keep children safe around the range?

- Children should be supervised around the range whenever it is in use, and after use until surfaces have cooled. You can also use the Lockout feature to help prevent children from accidentally turning on the cooktop or oven. The Lockout feature disables most control panel buttons and the cooktop control knobs. On some models, it also locks the oven door. Consult the Lockout section of your owner's manual for details. (In models without a self-clean option, the Lockout feature locks the controls but does not lock the oven door.)

15. My range is still dirty after running the EasyClean® cycle. What else should I do?

- The EasyClean® cycle only helps to loosen light soils in your oven range to assist in hand-cleaning of your oven. It does not automatically remove all soils after the cycle. Some scrubbing of your oven range is required after running the EasyClean® cycle.

16. I tried scrubbing my oven after running EasyClean®, but some soils still remain. What can I do?

- The EasyClean® feature works best when the soils are fully soaked and submerged in water before running the cycle and during hand-cleaning. If soils are not sufficiently soaked in water, it can negatively affect the cleaning performance. Repeat the EasyClean® process using sufficient water. Sugar-based and certain greasy soils are especially hard to clean. If some stubborn soils remain, use the Self Clean feature to thoroughly clean your oven. If a self-clean feature is not available, use a scraper to remove stubborn soil.

17. Soils on my oven walls are not coming off. How can I get my walls clean?

- Soils on the side and rear walls of your oven range may be more difficult to fully soak with water. Try repeating the EasyClean® process with more than the 1/5 of spray recommended.

18. Will EasyClean® get all of the soils and stains out completely?

- It depends on the soil type. Sugar-based and certain grease stains are especially hard to clean. Also, if stains are not sufficiently soaked in water, this can negatively affect cleaning performance. If stubborn or built-up stains remain, use the Self Clean feature. Refer to the Self Clean section of your owner's manual.
- Some models do not include a self-clean option. The EasyClean® feature may not be effective in removing heavy, built up soil. If a self-clean option is not available, it may help to use EasyClean® more often to avoid heavy soil build up.

19. Are there any tricks to getting some of the stubborn soils out?

- Scraping the soils with a plastic scraper before and during hand cleaning is recommended. If using a metal scraper, be careful not to damage the oven surface. Fully saturating soils with water is also recommended. Certain types of soil are harder to clean than others. For these stubborn soils, use the Self Clean cycle. Consult the Self Clean section of the owner's manual for details.

20. Is it safe for my convection fan, broil burner or heater element to get wet during EasyClean®?

- Yes. The convection fan, broiler burner or heater element may get a little wet during cleaning. However, direct spray onto the broil burner and heater elements is not necessary because these are self-cleaning during regular use.

21. Do I need to use the full contents of the spray bottle for EasyClean®?

- Yes. It is highly recommended that 4/5 of water be sprayed or poured on the bottom and an additional 1/5 of water be sprayed on walls and other soiled areas to fully saturate the soils for better cleaning performance.

22. I see smoke coming out of my oven range's cooktop vents during EasyClean®. Is this normal?

- This is normal. This is not smoke. It is actually water vapor (steam) from the water in the oven cavity. As the oven heats briefly during EasyClean®, the water in the cavity evaporates and escapes through the oven vents.

23. How often should I use EasyClean®?

- EasyClean® can be performed as often as you wish. However, if a self-clean option is not available on your oven, you may want to use the EasyClean® option often to prevent heavy, burnt-on soil from building up. EasyClean® works best when your oven is LIGHTLY soiled from such things as LIGHT grease splatter and small drops of cheese. Please refer to the EasyClean® section in your owner's manual for more information.

24. What is required for EasyClean®?

- A spray bottle filled with water, a scraper, a nonscratch scrubbing pad and a towel. You should not use abrasive scrubbers such as heavy-duty scouring pads or steel wool.

Before Calling for Service

Before you call for service, review this list. It may save you time and expense. The list includes common occurrences that are not the result of defective workmanship or materials in this appliance.



Symptoms	Possible Causes / Solutions						
Range is not level.	<ul style="list-style-type: none"> • Poor installation. Place oven rack in center of oven. Place a level on the oven rack. Adjust leveling legs at base of range until the oven rack is level. • Be sure floor is level and strong and stable enough to adequately support range. • If floor is sagging or sloping, contact a carpenter to correct the situation. Kitchen cabinet alignment may make range appear unlevel. Be sure cabinets are square and have sufficient room for range clearance. 						
Cannot move appliance easily. Appliance must be accessible for service	<ul style="list-style-type: none"> • Cabinets not square or are built in too tightly. Contact builder or installer to make appliance accessible. • Carpet interferes with range. Provide sufficient space so range can be lifted over carpet. • Anti-tip device engaged. 						
Oven control beeps and displays any F code error.	<p>Electronic control has detected a fault condition. Press Clear/Off to clear the display and stop beeping. Reprogram oven. If fault recurs, record fault number. Press Clear/Off and contact a Service agent.</p> <table border="1" data-bbox="512 1223 898 1458"> <thead> <tr> <th data-bbox="512 1223 639 1301">CODE</th> <th data-bbox="639 1223 898 1301">CAUSE</th> </tr> </thead> <tbody> <tr> <td data-bbox="512 1301 639 1379">F-3</td> <td data-bbox="639 1301 898 1379">Key short error</td> </tr> <tr> <td data-bbox="512 1379 639 1458">F-9</td> <td data-bbox="639 1379 898 1458">Oven not heating</td> </tr> </tbody> </table>	CODE	CAUSE	F-3	Key short error	F-9	Oven not heating
CODE	CAUSE						
F-3	Key short error						
F-9	Oven not heating						
Surface units will not maintain a rolling boil or cooking is not fast enough	<ul style="list-style-type: none"> • Improper cookware being used. <ul style="list-style-type: none"> ◦ Use pans which are flat and match the diameter of the surface unit selected. • In some areas, the power (voltage) may be low. <ul style="list-style-type: none"> ◦ Cover pan with a lid until desired heat is obtained. 						
Surface units do not work properly	<ul style="list-style-type: none"> • A fuse in your home may be blown or the circuit breaker tripped. <ul style="list-style-type: none"> ◦ Replace the fuse or reset the circuit breaker. 						

	<ul style="list-style-type: none"> • Cooktop controls improperly set. <ul style="list-style-type: none"> ◦ Check to see the correct control is set for the surface unit you are using
Surface unit stops glowing when changed to a lower setting	This is normal. The unit is still on and hot.
Areas of discoloration on the cooktop	<ul style="list-style-type: none"> • Food spillovers not cleaned before next use. <ul style="list-style-type: none"> ◦ See Cleaning the Glass-Ceramic Cooktop section. • Hot surface on a model with a light-colored cooktop. <ul style="list-style-type: none"> ◦ This is normal. The surface may appear discolored when it is hot. This is temporary and will disappear as the glass cools.
Frequent cycling on and off of surface units	<ul style="list-style-type: none"> • This is normal. <ul style="list-style-type: none"> ◦ The element will cycle on and off to maintain the heat setting.
Oven will not work	<ul style="list-style-type: none"> • Plug on range is not completely inserted in the electrical outlet. <ul style="list-style-type: none"> ◦ Make sure electrical plug is plugged into a live, properly grounded outlet. • A fuse in your home may be blown or the circuit breaker tripped. <ul style="list-style-type: none"> ◦ Replace the fuse or reset the circuit breaker. • Oven controls improperly set. <ul style="list-style-type: none"> ◦ See the Using the Oven section. • Oven too hot. <ul style="list-style-type: none"> ◦ Allow the oven to cool to below locking temperature
Steam is exhausted through the oven vent.	Cooking foods with high moisture produces steam. This is normal.
Appliance does not operate	<ul style="list-style-type: none"> • Make sure cord is plugged correctly into outlet. Check circuit breakers.



	<ul style="list-style-type: none"> • Service wiring is not complete. Contact your electrician for assistance. • Power outage. Check house lights to be sure. Call your local electric company for service
Oven light does not work	Replace or tighten bulb. See Changing the Oven Light section in this Owner's Manual.
Oven smokes excessively during broiling.	<ul style="list-style-type: none"> • Control not set properly. Follow instructions under Setting Oven Controls. • Meat too close to the element. Reposition the rack to provide proper clearance between the meat and the element. Preheat broil element for searing. • Meat not properly prepared. Remove excess fat from meat. Cut remaining fatty edges to prevent curling. • Insert on broiler pan wrong side up and grease not draining. Always place grid on the broiler pan with ribs up and slots down to allow grease to drip into pan. • Grease has built up on oven surfaces. Regular cleaning is necessary when broiling frequently. <ul style="list-style-type: none"> ◦ Old grease or food spatters cause excessive smoking.
Food does not bake or roast properly	<ul style="list-style-type: none"> • Oven controls improperly set. <ul style="list-style-type: none"> ◦ See the Using the Oven section. • Rack position is incorrect or the rack is not level. <ul style="list-style-type: none"> ◦ See the Using the Oven section. • Incorrect cookware or cookware of improper size being used. <ul style="list-style-type: none"> ◦ See the Using the Oven section. • Oven sensor needs to be adjusted. <ul style="list-style-type: none"> ◦ See Oven Temperature Adjustment in the Features section.
Food does not broil properly	<ul style="list-style-type: none"> • Oven controls improperly set. <ul style="list-style-type: none"> ◦ Make sure you press Broil.

	<ul style="list-style-type: none"> • Improper rack position being used. <ul style="list-style-type: none"> ◦ See the Broiling Guide. • Cookware not suited for broiling. <ul style="list-style-type: none"> ◦ Use broiling pan and grid.
Food does not broil properly	<ul style="list-style-type: none"> • Aluminum foil used on the broiling pan and grid has not been fitted properly and slit as recommended. <ul style="list-style-type: none"> ◦ See the Using the Oven section. • In some areas the power voltage may be low. <ul style="list-style-type: none"> ◦ Preheat the broil element for 5-7 minutes. ◦ See the Broiling Guide.
Oven temperature too hot or too cold	<ul style="list-style-type: none"> • Oven sensor needs to be adjusted. <ul style="list-style-type: none"> ◦ See Oven Temperature Adjustment in the Features section.
Scratches or abrasions on cooktop surface	<ul style="list-style-type: none"> • Coarse particles such as salt or sand between cooktop and utensils can cause scratches. Be sure the cooktop surface and bottoms of utensils are clean before using. Small scratches do not affect cooking and will become less visible with time. • Cleaning materials not recommended for glass-ceramic cooktop have been used. See Cleaning the Glass-Ceramic Cooktop in the MAINTENANCE section. • Cookware with rough bottom has been used. Use smooth, flat-bottomed cookware.
Metal marks	Scraping of metal utensils on cooktop surface. Do not slide metal utensils on cooktop surface. Use a glass-ceramic cooktop cleaning creme to remove the marks. See Cleaning the Glass-Ceramic Cooktop in the MAINTENANCE section
Brown streaks or specks	Boilovers are cooked onto surface. Use a blade scraper to remove soil. See Cleaning the Glass-Ceramic Cooktop in the MAINTENANCE section.
Areas of discoloration on cooktop	Mineral deposits from water and food. Remove using a glass-ceramic cooktop cleaning creme. Use cookware with clean, dry bottoms



<p>Oven will not Self Clean</p>	<ul style="list-style-type: none"> • The oven temperature is too high to set a Self Clean operation. <ul style="list-style-type: none"> ◦ Allow the range to cool and reset the controls. • Oven controls improperly set. <ul style="list-style-type: none"> ◦ See the Self Clean section. • A Self Clean cycle cannot be started if the oven lockout feature is active.
<p>"Crackling" or "popping" sound</p>	<ul style="list-style-type: none"> • This is the sound of the metal heating and cooling during both the cooking and Self Clean functions. <ul style="list-style-type: none"> ◦ This is normal.
<p>Fan noise</p>	<ul style="list-style-type: none"> • A convection fan may automatically turn on and off. <ul style="list-style-type: none"> ◦ This is normal
<p>Convection Fan stops</p>	<ul style="list-style-type: none"> • Convection fan stops during a convection bake cycle. <ul style="list-style-type: none"> ◦ This is normal and is done to allow for more even heating during the cycle. This is not a failure of the range and should be considered normal operation
<p>Displayed Time is flashing</p>	<p>This is normal. This means that the product has just been plugged in, or that it has experienced a power interruption. Press the Clock key and reset the time, or press any key to stop the flashing.</p>
<p>Excessive smoking during a Self Clean cycle.</p>	<ul style="list-style-type: none"> • Excessive soil. <ul style="list-style-type: none"> ◦ Press the Clear/Off button. Open the windows to rid the room of smoke. Wait until the Self Clean mode is cancelled. Wipe up the excess soil and reset the clean.
<p>Oven door does not open after a Self Clean cycle.</p>	<ul style="list-style-type: none"> • Oven is too hot. <ul style="list-style-type: none"> ◦ Allow the oven to cool below locking temperature. • Allow about one hour for the oven to cool after the completion of a Self Clean cycle. The door can be opened when the lock  is no longer displayed.



	<ul style="list-style-type: none"> The control and door may be locked.
The oven does not clean after a Self Clean cycle	<ul style="list-style-type: none"> Oven controls not properly set. <ul style="list-style-type: none"> See the Self Clean section. Oven was heavily soiled. <ul style="list-style-type: none"> Clean up heavy spillovers before starting the clean cycle. Heavily soiled ovens may need to Self Clean again or for a longer period of time.
CLEAN and door flash in the display.	<ul style="list-style-type: none"> The Self Clean cycle has been selected, but the door is not closed. <ul style="list-style-type: none"> Close the oven door.
LOCKED is on in the display when you want to cook.	<p>The oven door is locked because the temperature inside the oven has not dropped below the locking temperature.</p> <ul style="list-style-type: none"> Press the Clear/Off button. Allow the oven to cool.
Burning or oily odor emitting from the vent.	<p>This is normal in a new oven and will disappear in time.</p> <ul style="list-style-type: none"> To speed the process, set a Self Clean cycle for a minimum of 3 hours. See the Self Clean section.
Oven racks are difficult to slide.	<p>The shiny, silver-colored racks were cleaned in a Self Clean cycle.</p> <ul style="list-style-type: none"> Apply a small amount of vegetable oil to a paper towel and wipe the edges of the oven racks with the paper towel.
Moisture collects on oven window or steam comes from oven vent	<ul style="list-style-type: none"> This is normal when cooking foods high in moisture. Excessive moisture was used when cleaning the window.

Warning

This content is compiled from multiple sources and is provided for reference purposes only. It may not be complete or fully applicable to all situations. If you are unable to resolve your issue, please contact the product manufacturer or an authorized service provider for official support.

