

Learning About Your Countertop Oven

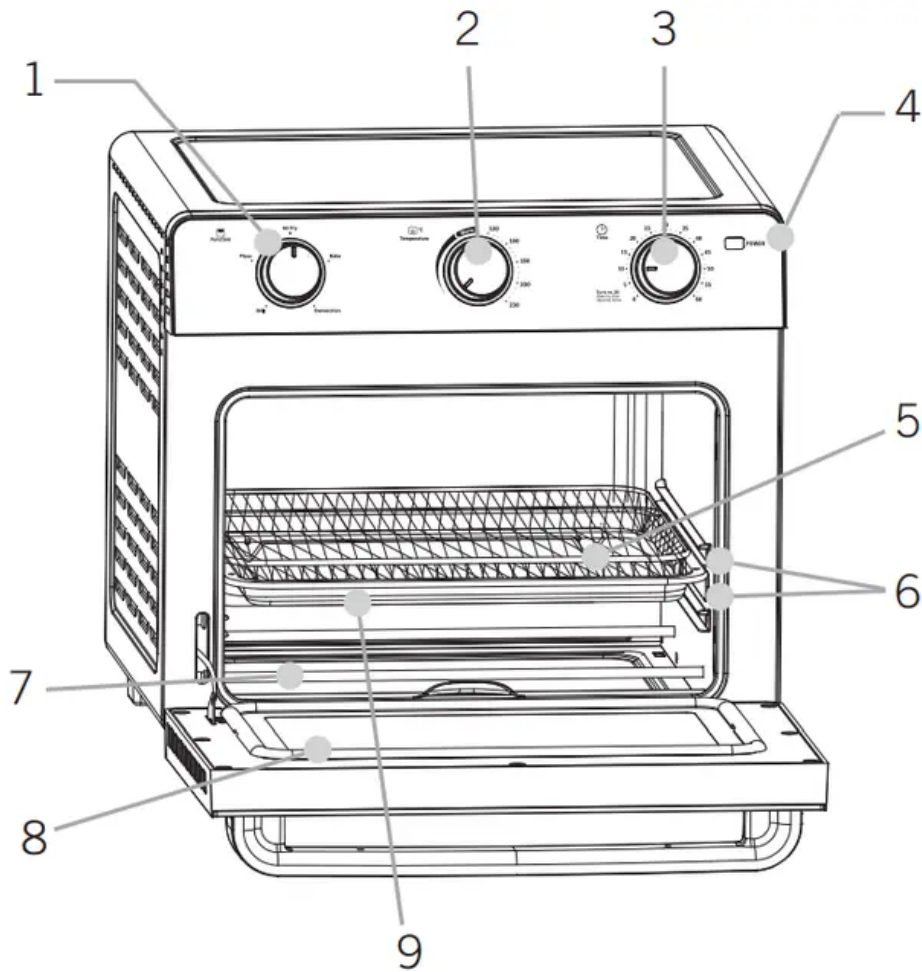

Function Setting

1. Function Setting

- Select cooking function by turning knob to desired setting.

2. Temperature Setting

- Adjust the dial thermostat to the desired temperature.

3. Timer setting

- Adjust the dial to the desired time.

4. Power Light

- Indicates that oven is plugged in and that the timer is set to begin warming.

5. Air Fry Basket

- Position on top of baking pan for all your air frying needs.

6. Two Rack

- Positions

7. Removable Crumb Tray

- Pulls out for easy cleaning.

8. Glass Door

- Allows you to see food cooking.

9. Baking Pan

- The baking pan can be used to accommodate a wide variety of foods.

Wire Rack

Use for pizza, bake and grill functions.

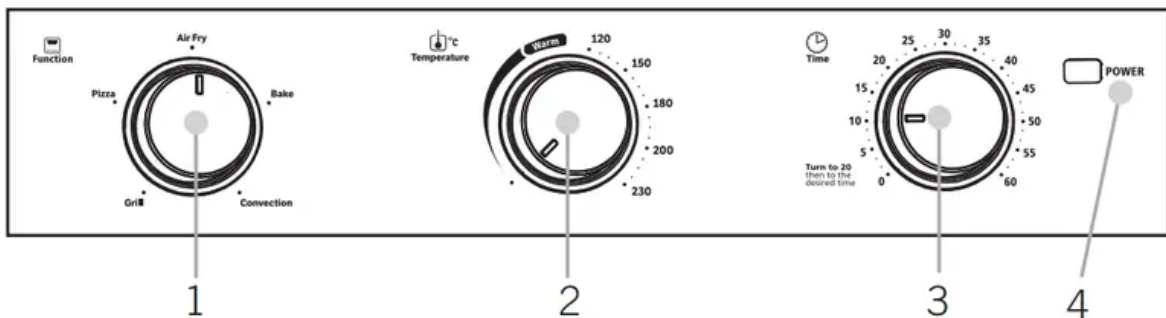

1. Function Setting

2. Temperature Setting

3. Timer Setting

4. Power Light

Using your Mini Bake & Grill

NOTE: During initial start up you may detect a slight smell and/or smoke. Turn the temperature to max and let run for approximately 5 minutes. If you are using your Countertop oven for the first time, please be sure to:

- Remove any stickers from the surface of the oven.
- Open oven door and remove all printed documents and paper from inside the Countertop Oven.
- Clean the rack, pan and air fry basket with hot water, a small amount of dishwashing liquid and a non-abrasive cleaning pad.

CAUTION: DO NOT IMMERSE THE BODY OF THE UNIT IN WATER.

- Dry the unit thoroughly before using.

- Select a location for the Countertop Oven. The location should be in an open area on a flat counter where the plug will reach an outlet.
- Plug the Countertop Oven into a 220-240 Volt AC electrical outlet.

WARNING: When Countertop Oven is in use or cooling down, please be sure there is a 6-inch clearance between the Countertop Oven and any other surface including cords. Be sure the cord is not resting against the back of the Countertop Oven.

To Open the Oven Door:

Step 1: Grab the center of the handle underhanded with fingertips (See Figure 1).

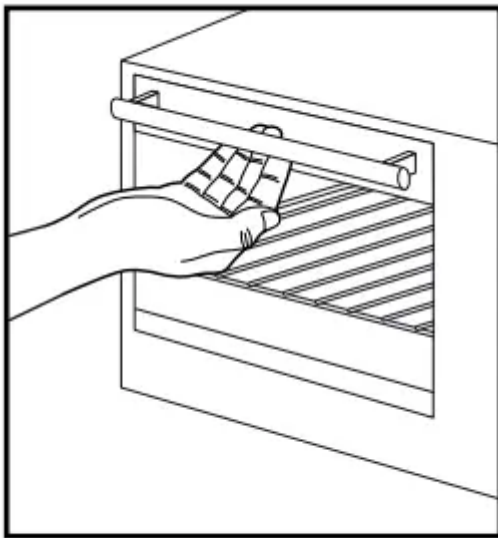

Figure 1

Step 2: Pull down the oven door carefully (See Figure 2).

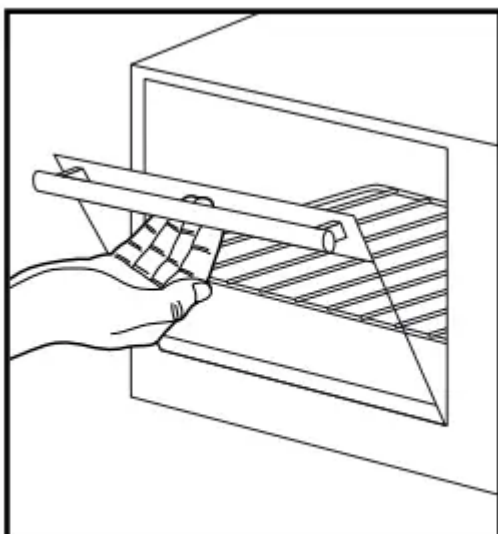
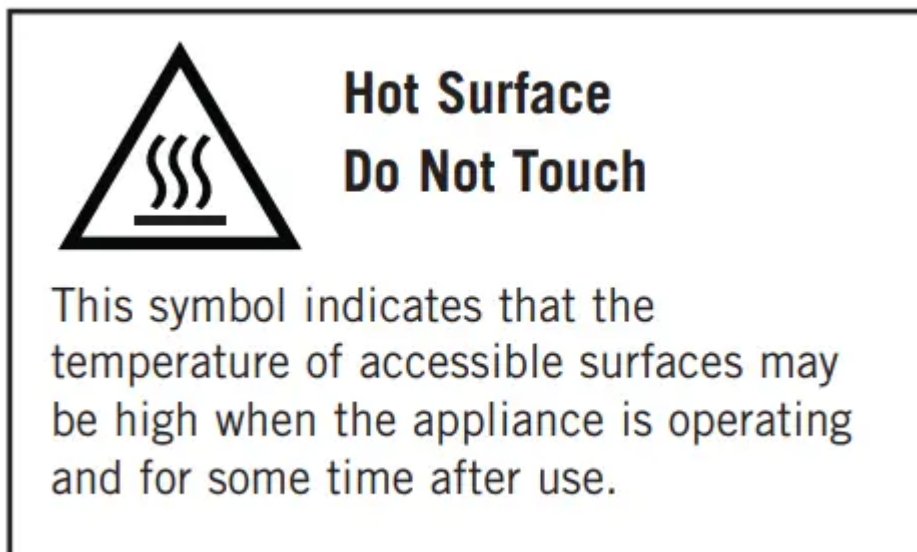

Figure 2

CAUTION: This appliance generates heat during use. Do not touch hot surfaces. Always use handles or knobs per above instructions.



CAUTION: Do not

place any load on the oven door, in an open condition.

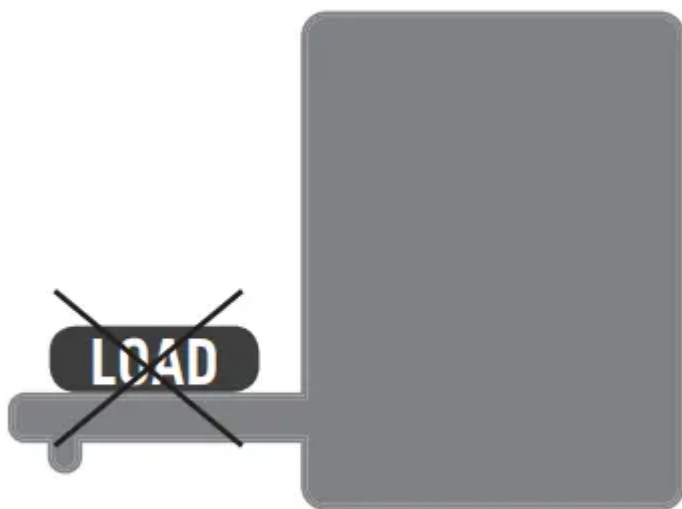

General Information

Timer / Timer Setting Tip

To set the timer for less than 20 minutes, ALWAYS turn the timer past the 20-minute mark to engage timer switch and then turn it back to desired time.

Heating Elements

The top and bottom heating elements will cycle ON and OFF to maintain the desired temperature. You may not see the heating elements glowing.

Positioning Rack

To accommodate a wide variety of foods the oven has two rack positions. (See Figure 3) Positioning of the rack will depend on the size of the food and desired browning. Before removing the rack allow the unit to cool.

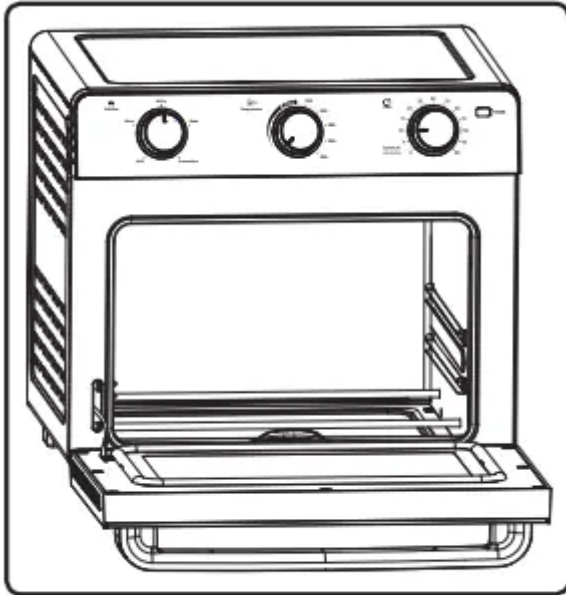

Figure 3

The oven rack may tilt downward causing food to shift when the rack is pulled out, proceed with caution.

PLEASE NOTE:

- For best air frying results, position the air fry basket on top of the baking pan in the top rack position.
- For best grilling results, position the baking pan in the top rack position.
- For best baking results, position the baking pan in the bottom rack position.
- For best toast and pizza results, position the rack in the top rack position.

Preheating the Oven

- Set to the desired Function.
- Turn the Temperature Control Knob to the desired temperature.
- Set the Timer Knob to desired time and allow 5-6 minutes for the oven to preheat.

Removing Food

Always open door fully and remove food carefully with oven mitt.

To Use the Timer Dial

After rotating the Temperature Dial to your desired temperature, select from the following options on the Timer Dial.

- For cooking time longer than 20 minutes, rotate the Timer Dial clockwise to your desired time. After cooking completes at the sound of the bell, the oven will automatically turn “Off.”
- For cooking time less than 20 minutes, rotate the Timer Dial clockwise past the 20 minute mark to activate the timer, then rotate back counterclockwise to your desired cooking time.

Using Your Countertop Oven

To use the Air Fry Function (See fig. 4)

- Arrange food on the Air Fry Basket and position on top of the Baking Pan in the top rack position.
- Set function to AIR FRY. When in Air Fry mode, the top heating elements and air fry fan will operate once the timer has been set.
- Turn the Temperature Control Knob to the desired temperature.
- Turn the Timer Knob to the desired time.

NOTE: If cook time is less than 20 minutes, you must turn Timer past the 20 minutes mark to engage the timer then back to desired time.

NOTE: The top heating elements will cycle ON and OFF to maintain the desired temperature.

NOTE: Toss food evenly in oil if desired before placing food in oven.

WARNING: Cooked food, air fry basket, baking pan, and door can be very hot, handle with care. Do not leave the unit unattended.

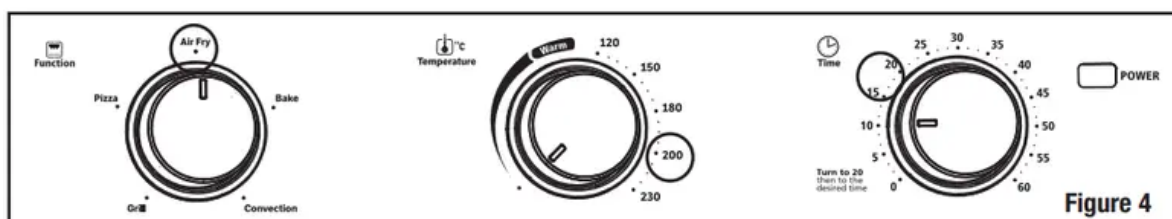

FAQs about Air Frying

Should I toss my food in oil?

Answer: Not all foods will benefit from being tossed in oil prior to being air fried. Frozen foods and foods with a high fat content such as chicken wings or bacon do not require oil. To achieve crispy and browned results on foods such as hand-cut fries or vegetables, evenly coat food with about one tablespoon of oil.

Do I need to flip or toss my food halfway through the cooking cycle?

Answer: Large quantities of food can benefit from being tossed halfway through the cooking cycle to ensure even cooking and browning

To Cook Toast (See fig 5)

NOTE: Different types of bread require different settings. Lighter breads and waffles require a lighter setting. Darker breads, muffins, and English muffins require a darker setting.

- Arrange food on the wire rack.
- Set function to PIZZA. When in Pizza mode, both the top and bottom heating elements will operate once the timer has been set.
- Turn the Temperature Control Knob to the 230°C setting.
- To set the timer, turn the timer past the 20 minute mark to engage timer switch and set back to desired toast between 0 and 10 minutes.

NOTE: The top and bottom heating elements will cycle ON and OFF to maintain the desired temperature.

WARNING: Cooked food, metal rack, and door can be very hot, handle with care. Do not leave the unit unattended.

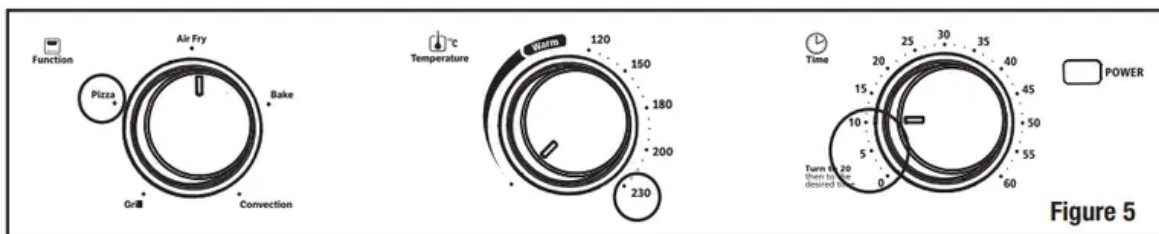

To Use the Pizza Function (See fig. 5)

NOTE: Different types of pizza require different settings. Hand-made pizza require a lighter setting. Frozen pizza require a darker setting.

- Arrange food on the wire rack.
- Set function to PIZZA. When in Pizza mode, both the top and bottom heating elements will operate once the timer has been set.
- For frozen pizza, turn the Temperature Control Knob to the 180°C setting.
- For home-made pizza, turn the Temperature Control Knob to the 200°C setting.
- To set the timer, turn the timer past the 20 minute mark to engage timer switch and set back to desired time between 0 and 10 minutes.

NOTE: The top and bottom heating elements will cycle ON and OFF to maintain the desired temperature.

WARNING: Cooked food, metal rack, and door can be very hot, handle with care. Do not leave the unit unattended.

To Use the Bake Function (See fig. 6)

- Arrange food on the wire rack or in the baking pan.
- Set function to BAKE. When in Bake mode, both the top and bottom heating elements will operate once the timer has been set.
- Turn the Temperature Control Knob to the desired temperature.
- Turn the Timer Knob to the desired time.

NOTE: The top and bottom heating elements will cycle ON and OFF to maintain the desired temperature.

NOTE: If cook time is less than 20 minutes, you must turn Timer past the 20 minutes mark to engage the timer back to desired time.

WARNING: Cooked food, metal rack, and door can be very hot, handle with care. Do not leave the unit unattended.

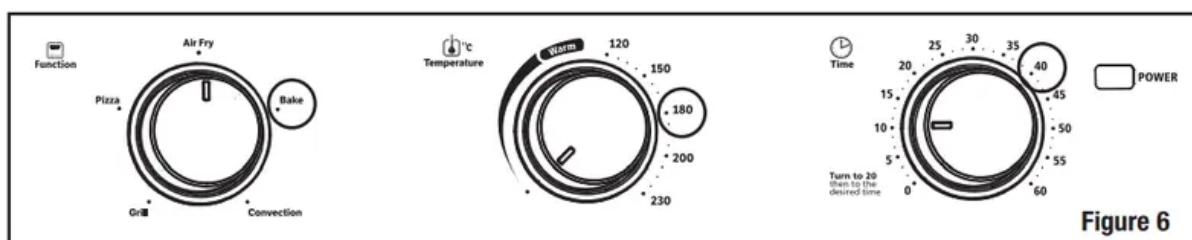

To Use The Convection Bake Function (See fig. 7)

- Arrange food on the wire rack or in the baking pan.
- Set function to Convection. When in Convection mode, both the top and bottom heating elements will operate once the timer has been set.
- Turn the Temperature Control Knob to the desired temperature.
- Turn the Timer Knob to the desired time.

NOTE: If cook time is less than 20 minutes, you must turn Timer past the 20 minutes mark to engage the timer back to desired time.

NOTE: The top and bottom heating elements will cycle ON and OFF to maintain the desired temperature.

WARNING: Cooked food, metal rack, and door can be very hot, handle with care. Do not leave the unit unattended.

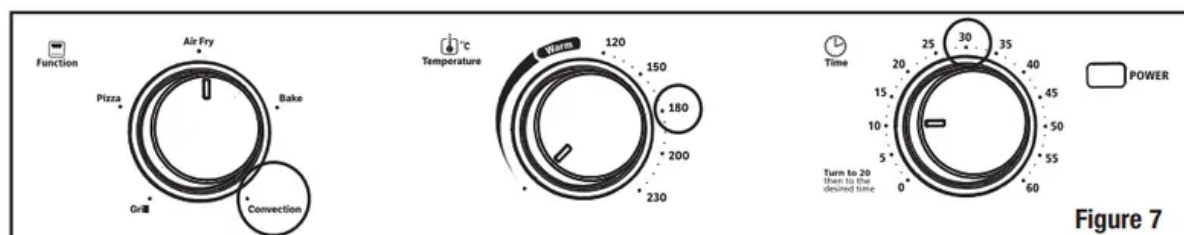

FAQs About Convection Bake

What is Convection Bake?

Answer: In your Countertop Oven there is a built in fan that circulates the hot air in the oven chamber to better heat the food.

How do I adjust the time for Convection Bake?

Answer: On average, convection will shorten the cooking time by 30% but it varies by food. It is suggested to go with a shorter cooking time to start with and then add time if it is needed.

What are the best foods to use with Convection Bake?

Answer: While a shorter cook time is often desirable, baked goods in particular benefit from convection cooking as the circulating air keeps oven temperature consistent throughout.

To Use the Adjustable Grill Function (See fig. 8)

- Arrange food on the baking pan.
- Close the door to the first notch, leaving a small gap at the top. This will ensure adequate airflow during grilling.
- Set function to Grill. When in Grill mode, the top heating elements will operate once the timer has been set.
- Turn the Temperature Control Knob to the desired temperature.
- Turn the Timer Knob to the desired time. Turn food over about halfway through the grilling time.

NOTE: If cook time is less than 20 minutes, you must turn Timer past the 20 minutes mark to engage the timer back to desired time.

NOTE: The top heating elements will cycle ON and OFF to maintain the desired temperature.

WARNING: Cooked food, metal rack, and door can be very hot, handle with care. Do not leave the unit unattended.

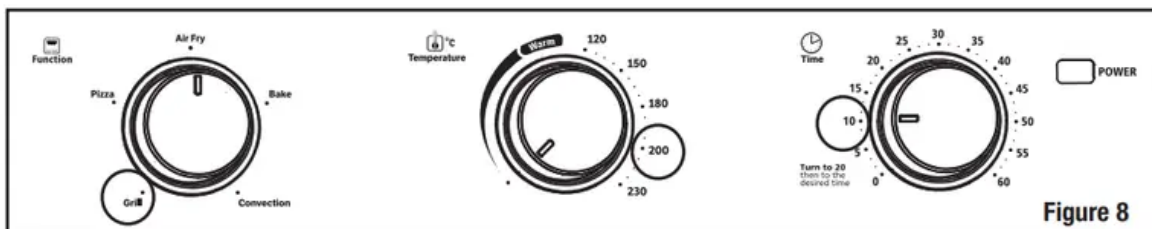

Figure 8

To Use the Warm Function (See fig. 9)

NOTE: The Warm Function is for warming and keeping food warm after heating.

- Arrange food on the wire rack, in the baking pan, or in the air fry basket.
- Set Function to BAKE.

- Turn the Temperature Control Knob to the desired WARM temperature setting.
- Turn the Timer Knob to the desired time.

NOTE: If cook time is less than 20 minutes, you must turn Timer past the 20 minutes mark to engage the timer back to desired time.

WARNING: Cooked food, metal rack, and door can be very hot, handle with care. Do not leave the unit unattended.

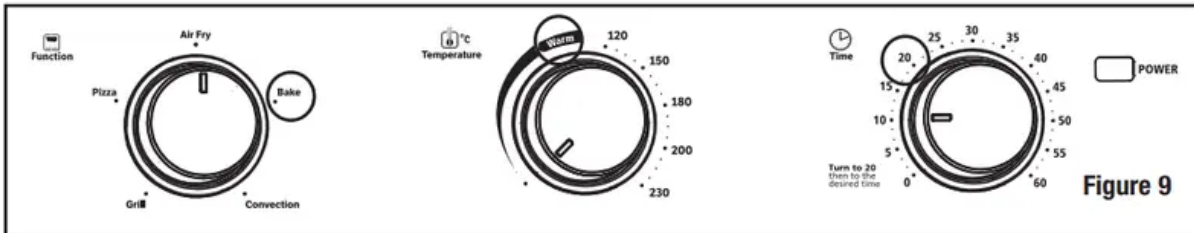

Cleaning Your Countertop Oven

1. Before cleaning your Sunbeam® countertop oven, unplug it and allow it to cool.
2. To clean, wipe with damp cloth.
 - **CAUTION:** DO NOT IMMERSE IN WATER. Make sure to use only mild, soapy water. Abrasive cleaners, scrubbing brushes and chemical cleaners will damage the unit. Empty crumb tray frequently to avoid accumulation of crumbs. Air fry basket, wire rack, and baking pan are dishwasher safe. (top of dishwasher only).

This appliance has no user serviceable parts. Any servicing beyond that described in the Cleaning Section should be performed by an Authorized Service Representative only. See Warranty Section.

Storing Your Countertop Oven

Allow the appliance to cool completely before storing. If storing the countertop oven for long periods of time, make certain that the countertop oven is clean and free of food particles. Store the countertop oven in a dry location such as on a table or countertop or cupboard shelf. Other than the recommended cleaning, no further user maintenance should be necessary.

Air Fry Cooking Chart

FOOD	WEIGHT	FUNCTION	TEMPERATURE (°C)	TIME (MIN)	OIL?
POTATOES					
Hand-Cut Fries	500g	AIR FRY	200 degrees	20 min	Yes
Hand-Cut Sweet Potato Fries	500g	AIR FRY	200 degrees	20 min	Yes
Frozen Hash Brown	600g	AIR FRY	200 degrees	15 min	No
Frozen Fries (Thick Cut)	700g	AIR FRY	230 degrees	20-25 min	No
Frozen Fries (Thin Cut)	750g	AIR FRY	230 degrees	10-15 min	No
MEAT/POULTRY/FISH					
Chicken Wings	700g	AIR FRY	200 degrees	25 min	No
Steak	230g	AIR FRY	230 degrees	5-8 min	No
Pork Chops	230g	AIR FRY	200 degrees	20 min	No
Hamburger	115g	AIR FRY	200 degrees	10-15 min	No
Breaded Chicken Breast	500g	AIR FRY	180 degrees	10 min	No
Breaded Fish	500g	AIR FRY	200 degrees	10 min	No
Bacon	230g	AIR FRY	200 degrees	8-10 min	No
SNACKS					
Frozen Chicken Nuggets	500g	AIR FRY	200 degrees	10-15 min	No
Frozen Mozzarella Sticks	500g	AIR FRY	200 degrees	8-10 min	No
Frozen Onion Rings	285g	AIR FRY	200 degrees	10 min	No
Fresh Mixed Vegetables	700g	AIR FRY	200 degrees	20 min	Yes

Note: The oven does not need to be pre-heated for Air Frying.

Note: Cook times are estimates and may vary based on food type and preparation.

Helpful Tips / Troubleshooting

Problem, Potential & Cause Solution

1. Overcooked / Undercooked Foods

- Incorrect temperature or time setting
 - You may have to adjust the time and temperature to desired taste. To set the timer for less than 20 minutes, turn the timer past the 20-minute mark to engage timer switch and then turn it back to desired time.
 - Because your countertop oven is smaller than your regular oven, it will heat up faster and generally cook in shorter periods of time.

- Rack placement
 - Refer to “Positioning Rack” Section, Page 4. Rack may need to be adjusted to accommodate food type.

2. Burnt Smell

- First Use
 - It is recommended to heat countertop oven to 230°C for approximately 15 minutes to eliminate any manufacturing residue that may remain after shipping.
- Food build-up inside oven, on heating elements or in crumb tray.
 - Refer to “Cleaning Your Countertop Oven” Section, Page 6.

3. Oven does not turn ON

- Unit is unplugged
 - Plug the countertop oven into a 220- 240 volt AC electrical outlet.
- Timer was not turned past 20 minute mark.
 - Set timer knob and temperature knob to desired setting. Both must be turned on to operate the countertop oven.

4. Only one heating element is heating up

- Function setting selection determines which heating element will operate.
 - When cooking pizza or toast, make sure the oven is not set to grill setting and temperature is set at 230°C.

5. Heating elements do not stay ON

- Heating elements will cycle ON and OFF to maintain proper heat.
- You may not see elements glowing.
 - Be certain that function is as desired.

Recipes

Garlic Parmesan Roasted Potatoes

- 1 sprig fresh rosemary, leaves removed
- 5 cloves garlic, minced
- 1kg new potatoes, cut into quarters
- Salt and ground pepper, to taste
- 2 tablespoons olive oil

- ½ cup parmesan cheese, grated

Peel and cut the potatoes into quarters. Rinse well to remove starch. Pat dry. In a large bowl, mix the potato with the rest of the ingredients. Place the potatoes onto the air fry basket and cook on air fry for 25-30 mins at 200°C, or until potatoes are crisp and golden, tossing halfway through cook time.

Coconut Prawns

- 20 large prawns, peeled and deveined
- 2 large eggs, beaten
- 1 cup shredded coconut
- 1 cup panko breadcrumbs
- 1 cup flour, all-purpose white
- Salt and ground pepper, to taste

In a large bowl, mix shredded coconut and panko. Season to taste with salt and pepper. Place flour and eggs in 2 separate bowls. Dredge the prawns in flour and then egg. Coat the prawns thoroughly with the coconut mixture. Lay prawns out evenly on air fry basket and drizzle olive oil on top. Cook on air fry for 8-10 minutes at 180°C, or until prawns is cooked through.

Honey Garlic Chicken Wings

- Ingredients
- 12 chicken wings
- ½ cup corn flour
- 1 teaspoon salt
- 1 teaspoon
- Garlic powder
- Garlic Honey Sauce
- 1 teaspoon soy sauce
- 1 tablespoon unsalted butter
- 4 teaspoons minced garlic
- ¼ cup honey

Season chicken wings lightly with salt and garlic powder. Place corn flour in a bowl and coat the chicken wings on all sides, shaking off any excess flour. Evenly lay the wings on the air fry basket and cook on air fry for 30 minutes, at 190°C, flipping halfway through cooking cycle. While the wings are cooking, heat the butter and garlic in a small saucepan. Once melted, add the rest of the ingredients and bring to a light boil for about 2 minutes. Once the wings are crispy and cooked, toss them in a large bowl with the finished sauce until fully coated.

Pancetta Roasted Brussel Sprouts

- 500g Brussel sprouts, trimmed and halved
- 115g chopped Pancetta
- Salt and pepper to taste
- 2 tablespoons olive oil
- 2 teaspoons minced garlic
- 1 tablespoon balsamic vinegar

In a large bowl, combine all ingredients and evenly lay on air fry basket. Cook mixture on air fry for 15 minutes at 180°C, or until cooked thoroughly, tossing halfway through cooking cycle.

Warning

This content is compiled from multiple sources and is provided for reference purposes only. It may not be complete or fully applicable to all situations. If you are unable to resolve your issue, please contact the product manufacturer or an authorized service provider for official support.