

# About Your RobotVac

## What's in the Box

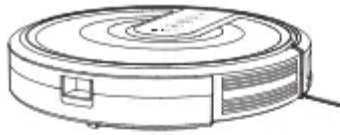

RoboVac

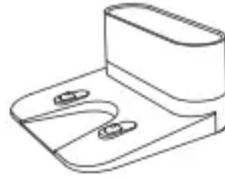

Charging Base



Remote Control  
(AAA Battery x2)



Power Adapter



Cleaning Tool

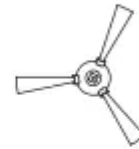

Side Brushes (x4)

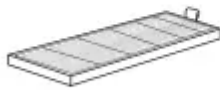

Additional  
High-Performance  
Filter



Additional  
Foam Filter



Cable Ties (x5)



Boundary Strips  
6.6 ft/2 m Length  
(T2117 only)



Adhesive Tapes (x2)  
(T2117 only)



Owner's Manual &  
Other Documents

## RobotVac Anatomy

### Top & Side

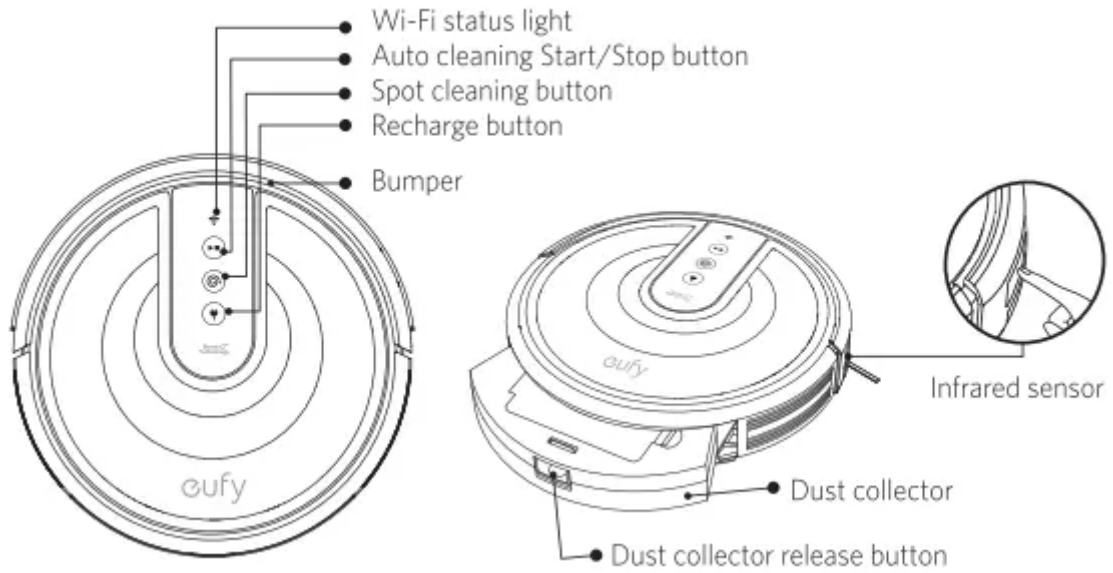

**Bottom**

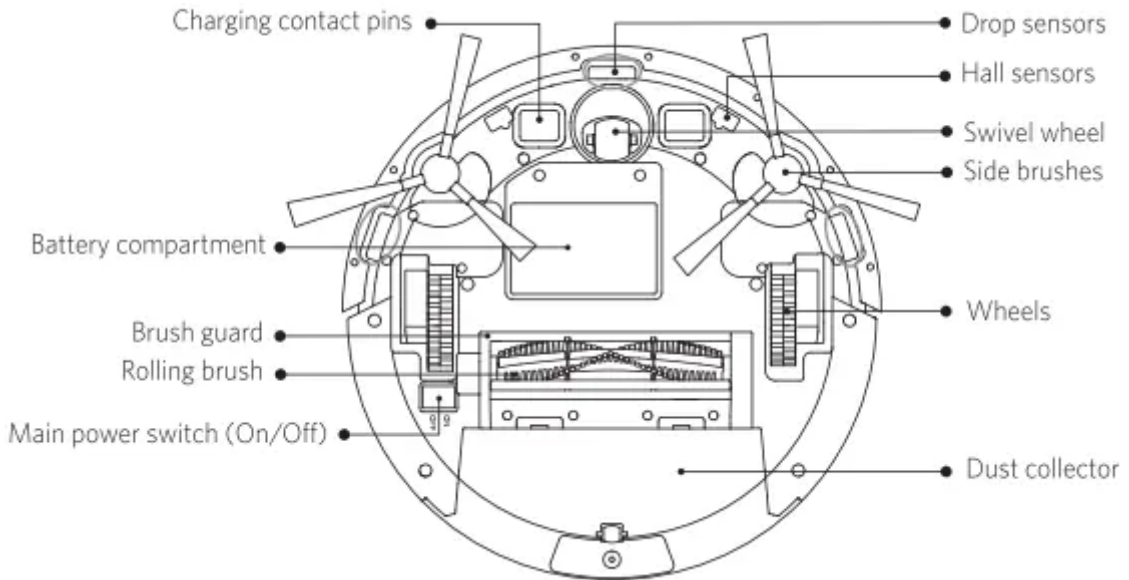

**Dus Collector**



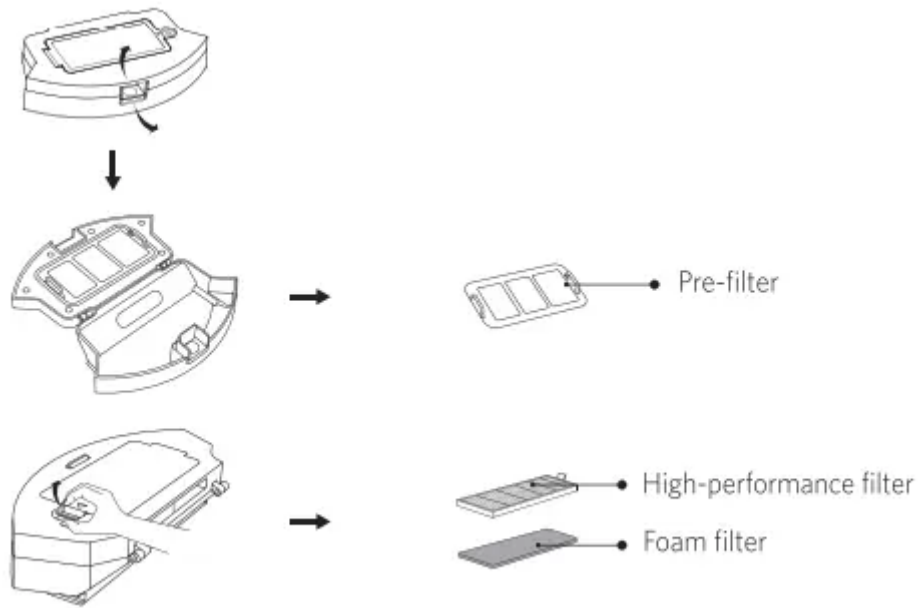

### Suction Inlet

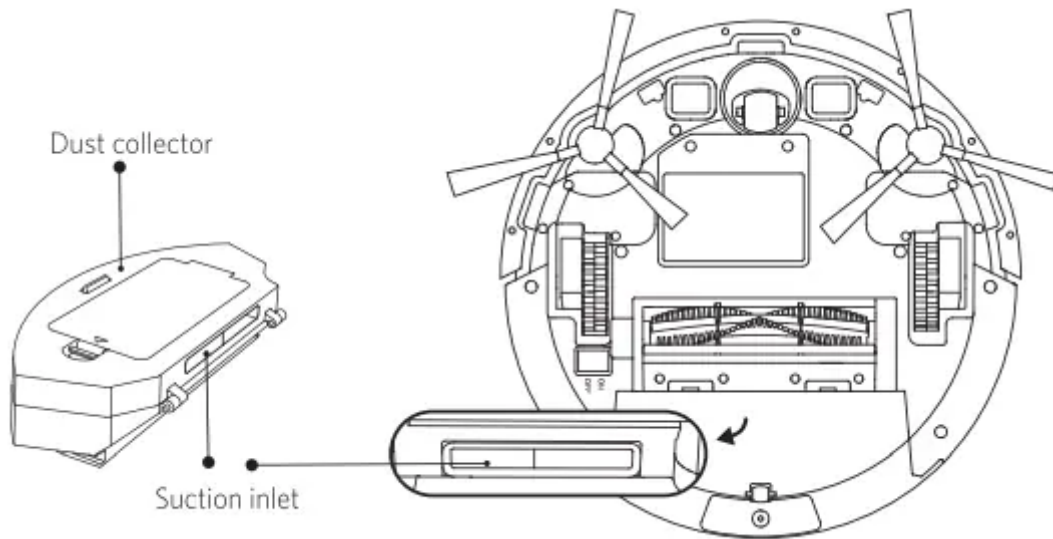

### Charging Base

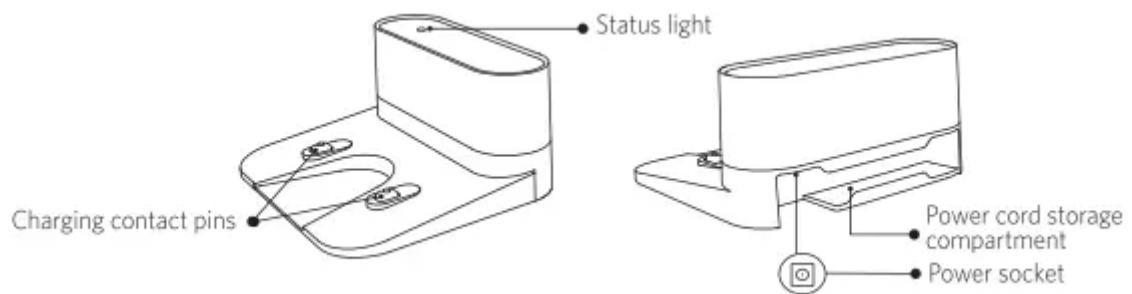

### Remote Control



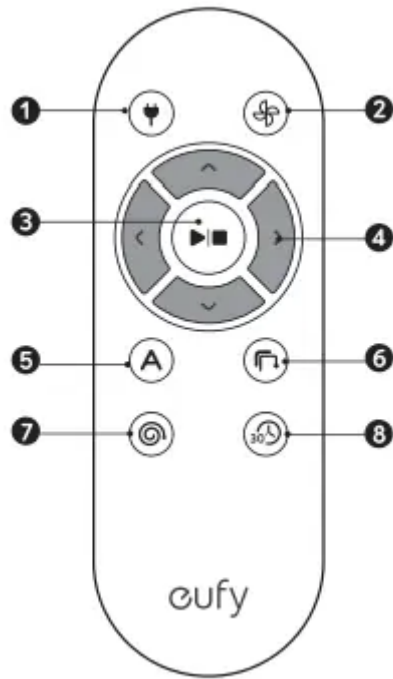

1. Return RoboVac to Charging Base
2. Adjust suction power level in Auto and Quick Cleaning modes
3. Start Auto cleaning / Stop cleaning
4. Control cleaning direction manually
5. Start Auto cleaning
6. Start Edge cleaning
7. Start Spot cleaning
8. Start Quick cleaning

## Button & Indicators

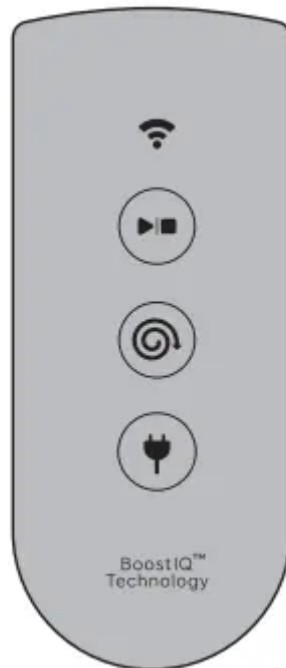

**Start/Stop Cleaning:** Reset the Wi-Fi Connection (Press and hold for 10 seconds until RoboVac beeps)

- Solid Blue: standby or cleaning
- Flashing/Solid red: error

Refer to the “Troubleshooting>Error Tone” section in this manual for solutions.



**Spot Cleaning**

- Flashing blue: Spot Mode



**Return to Charging Base**

- Flashing blue: returning to charging base
- Flashing orange: low power and returning to charging base
- Breathing orange (when docked to charging base): charging
- Solid blue (when docked to charging base): fully charged

When you use the Find My Robot function via the EufyHome app, all three LED indicators flash blue and RoboVac beeps once.

To conserve power, all LED indicators automatically turn off when:

- RoboVac is not docked to the Charging Base and has been inactive for 10 minutes;
- RoboVac is fully charged for 10 minutes.

 (Wi-Fi Status Light)	Status
Slowly flashing blue	Waiting for connection
Rapidly flashing blue	Connecting with your wireless router
Solid blue	Connected to your wireless router

## Using the RoboVac

### Important Tips Before Use

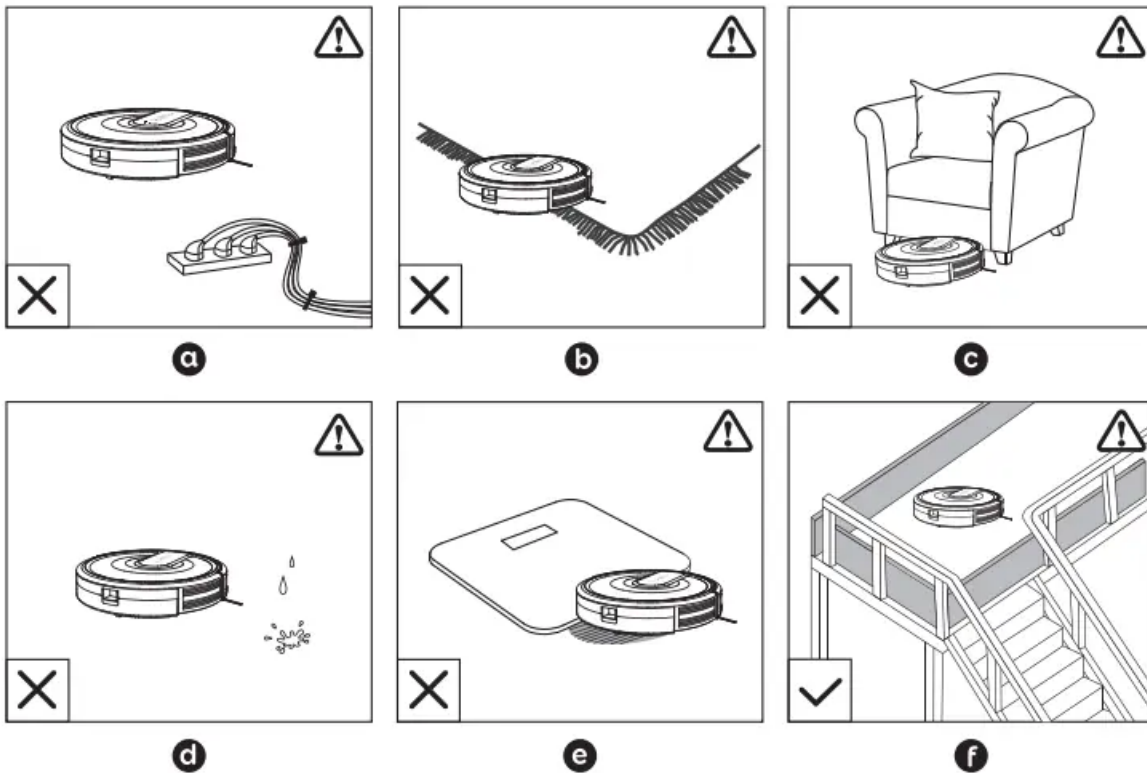

**a.** Remove power cords and small objects from the floor that may entangle RoboVac. You can use the supplied cable ties to organize your wires and power cords.

**b.** Fold tasseled edges of area rugs underneath to prevent tangling RoboVac. Avoid cleaning very dark-colored high-pile rugs or rugs thicker than 1.02 in/26 mm as they may cause RoboVac to malfunction.

**c.** Keep RoboVac away from spaces lower than 2.87 in/73 mm to prevent RoboVac from getting stuck. If necessary, place a physical barrier to block off the problem areas.

**d.** Keep RoboVac away from wet areas.

e. RoboVac may climb on top of objects less than 0.63 in/16 mm in height. Remove these objects if possible.

f. Anti-drop sensors prevent RoboVac from tumbling down stairs and steep drops. They may work less effectively if dirty or used on reflective/very dark-colored floors. It is recommended to apply Boundary Strips (T2117 only) or physical barriers to block off areas where RoboVac may fall.

## Preparation

1. Install the side brushes before use.

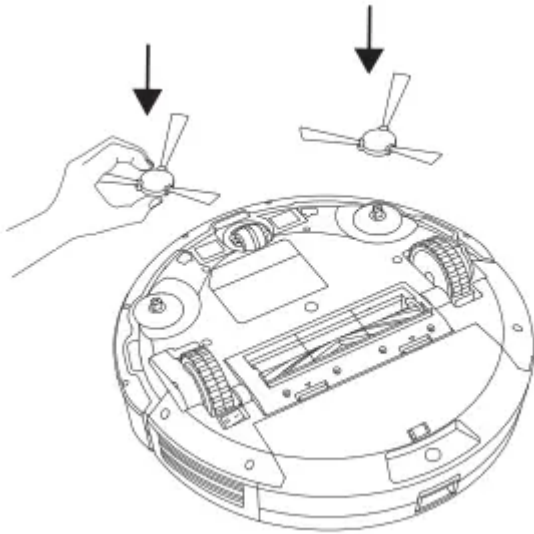

2. Turn on the main power switch on the bottom of RoboVac.

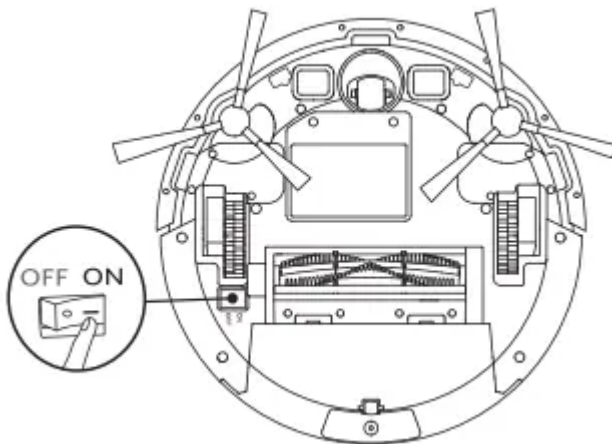

3. Place the Charging Base on a hard, level surface and against a wall.

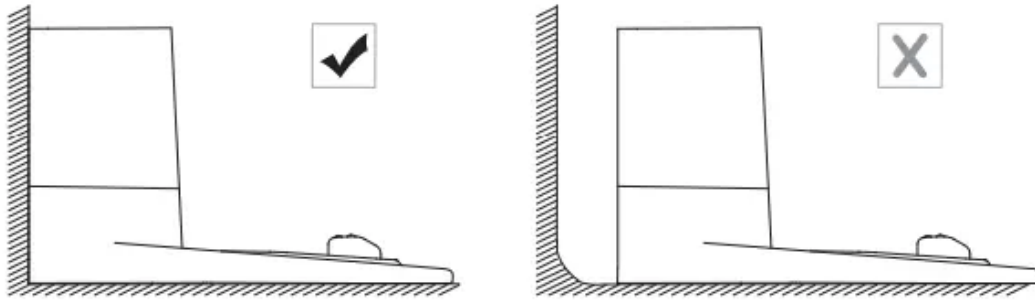

4. Remove objects within 3 ft/1 m of the left and right side and within 6 ft/2 m of the front of the Charging Base.

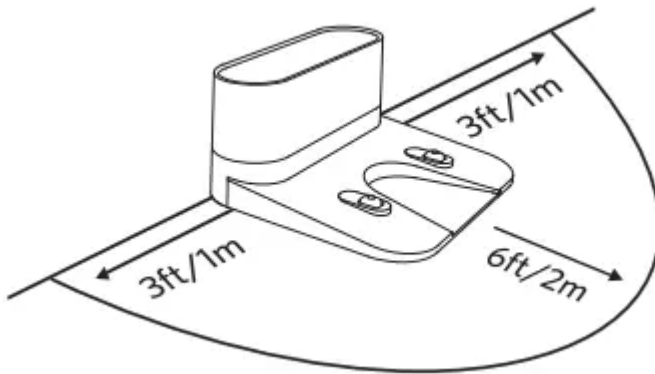

5. Connect the round connector of the adapter into the power socket on the Charging Base and the other end into a wall outlet. When the Charging Base connects to AC power, the LED indicator on the Charging Base is SOLID WHITE.

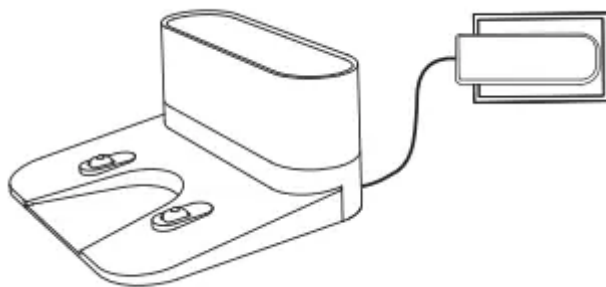

## Charge Your RoboVac

- RoboVac has a pre-installed rechargeable battery that has to be fully charged before use.
- RoboVac returns to the Charging Base at the end of a cleaning cycle or when its battery is running low.

**Method 1:** Attach RoboVac to the Charging Base by aligning its charging pins with the charging pins on the base.

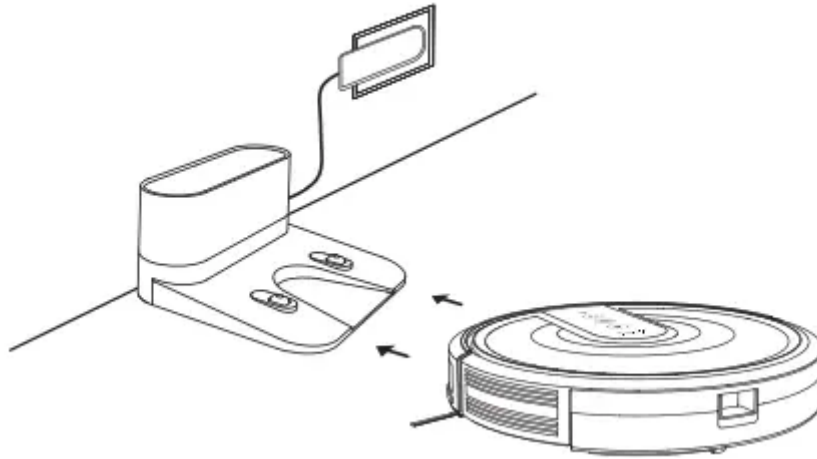

**Method 2:** Press  on RoboVac or on the remote control to return RoboVac to the Charging Base.

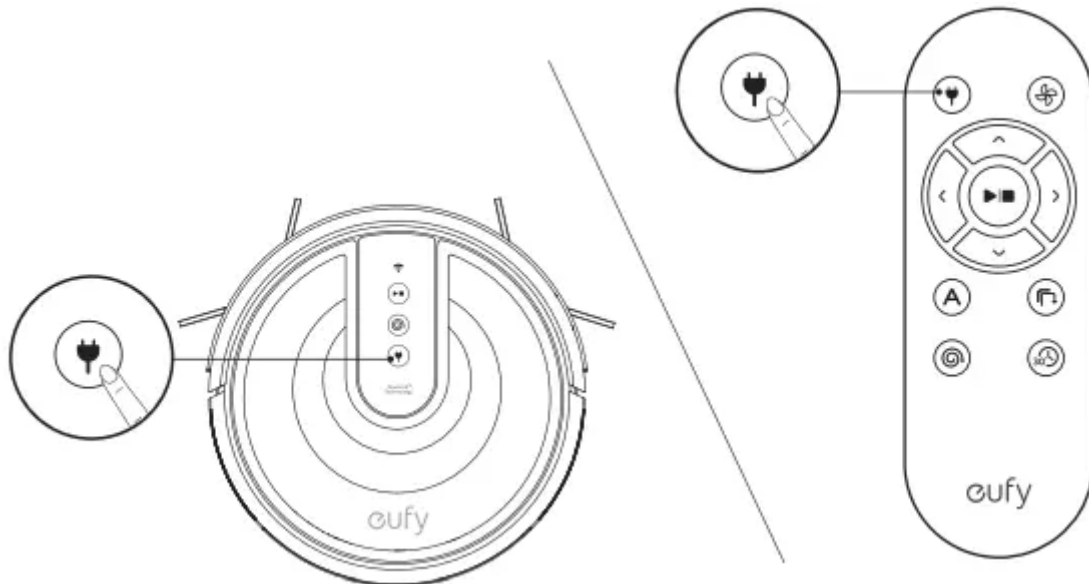

## Use Your RoboVac with the EufyHome App

To enjoy all available features, it is recommended to control your RoboVac via the EufyHome app

**Before you start, make sure that:**

- Your smartphone or tablet is connected to a Wi-Fi network
- Your smartphone or tablet is running iOS 8.0 (or above) or Android 4.4 (or above)
- The 2.4GHz band wireless signal is enabled on your wireless router.
- The Wi-Fi status light on RoboVac is slowly flashing blue.
- RoboVac is attached to the Charging Base to ensure it has enough power during setup





1. Download the EufyHome app from the App Store (iOS devices) or Google Play (Android devices)
2. Open the app and create a user account.
3. Tap the "+" icon in the top right corner to add RoboVac to your EufyHome account.
4. Follow the instructions in the app to set up the Wi-Fi connection
  - After connecting successfully, you can control RoboVac via the app.
  - With the app, you can select a cleaning mode, set the time, schedule a cleaning, view the system status, receive notifications and access additional features.

### Wi-Fi Status Light

	Slowly flashing blue	Waiting for connection
	Rapidly flashing blue	Connecting with your wireless router
	Solid blue	Connected to your wireless router

### Reset the Wi-Fi Connection

Press and hold   on RoboVac for 10 seconds until RoboVac beeps to reset the Wi-Fi connection if necessary.

- You will hear a beep when the Wi-Fi connection has been reset and the Wi-Fi status light will slowly flash blue. Now you can follow the Wi-Fi instructions in the EufyHome app to set up the Wi-Fi connection

### Schedule Cleaning

With the EufyHome app, you can schedule RoboVac to start cleaning at a particular time.

You can set the time and customize the cleaning schedules from Sunday to Saturday on the EufyHome app. This function is available in the app only.

## Start/ Stop Cleaning

Make sure the main power switch on the bottom of RoboVac is turned on before use.

You can also start or stop cleaning via the EufyHome app.

1. Press  on RoboVac or  on the remote control to start cleaning in Auto Mode.

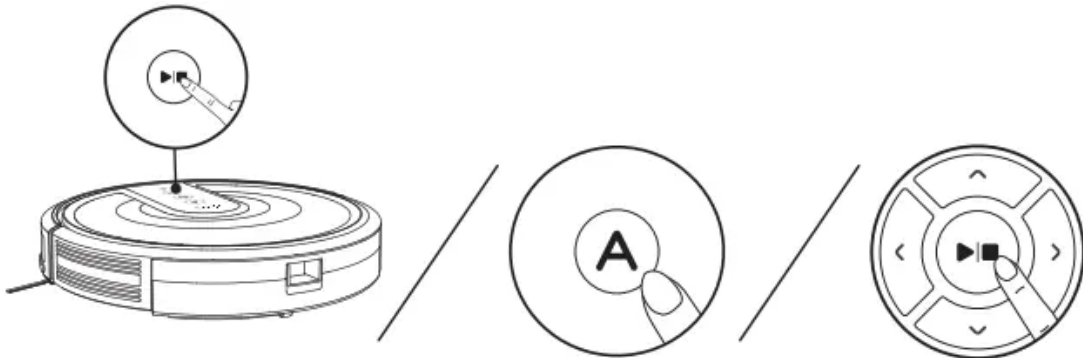

2. Press  on RoboVac or on the remote control to stop cleaning.

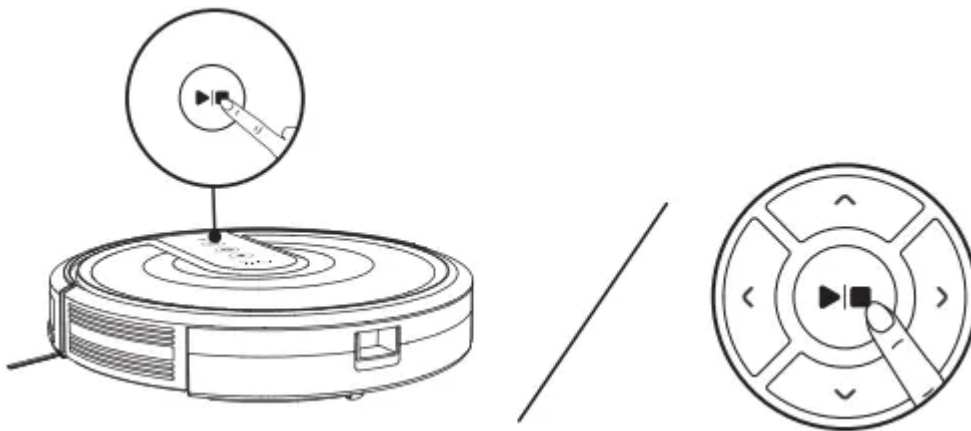

## Select a Cleaning Mode

### 1. Auto cleaning

RoboVac optimizes its cleaning path by selecting different cleaning modes automatically until cleaning is complete. This is the most commonly used cleaning mode.

- Press  on RoboVac or  on the remote control to start cleaning in Auto Mode.

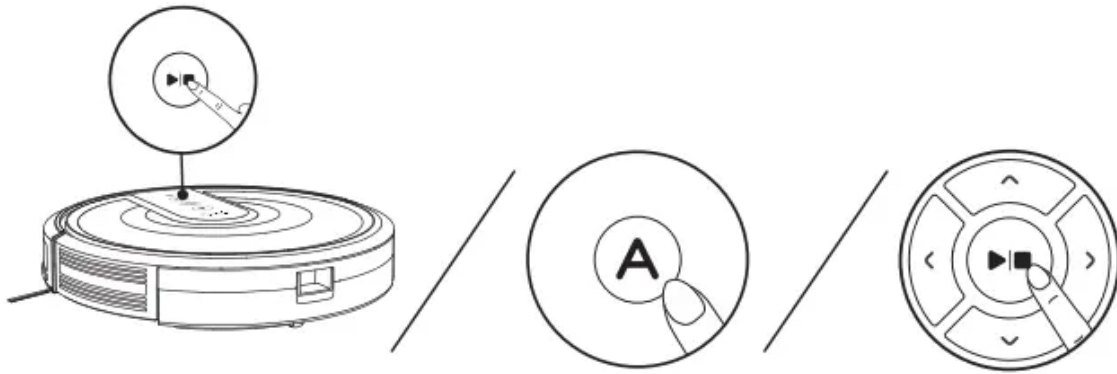

### **BoostIQ Feature**

When the BoostIQ feature is enabled, RoboVac will automatically increase the suction power if it detects stronger power is needed to ensure the best clean. BoostIQ is ideal for cleaning thicker carpets and hard-to-sweep messes, which will reduce the total cleaning time, but increase the noise level. If the vacuuming noise caused by BoostIQ disturbs you, you can disable this feature. This feature only works in Auto and Quick cleaning modes.

In Auto or Quick cleaning mode, press  on the remote control repeatedly to adjust the suction power level. The corresponding icon is displayed on the remote control.

Suction Power Level	Beeps
Standard power	●
BoostIQ™ (Default, automatically switches between Standard and Enhanced power)	●●
Maximum power	●●●

## **2. Spot cleaning**

RoboVac intensively cleans a specific area in a spiral pattern, useful if there is a concentrated area of dust or debris. In Spot mode, RoboVac will stop cleaning after 2 minutes.

Press  on RoboVac or on the remote control to start cleaning in Spot Mode.

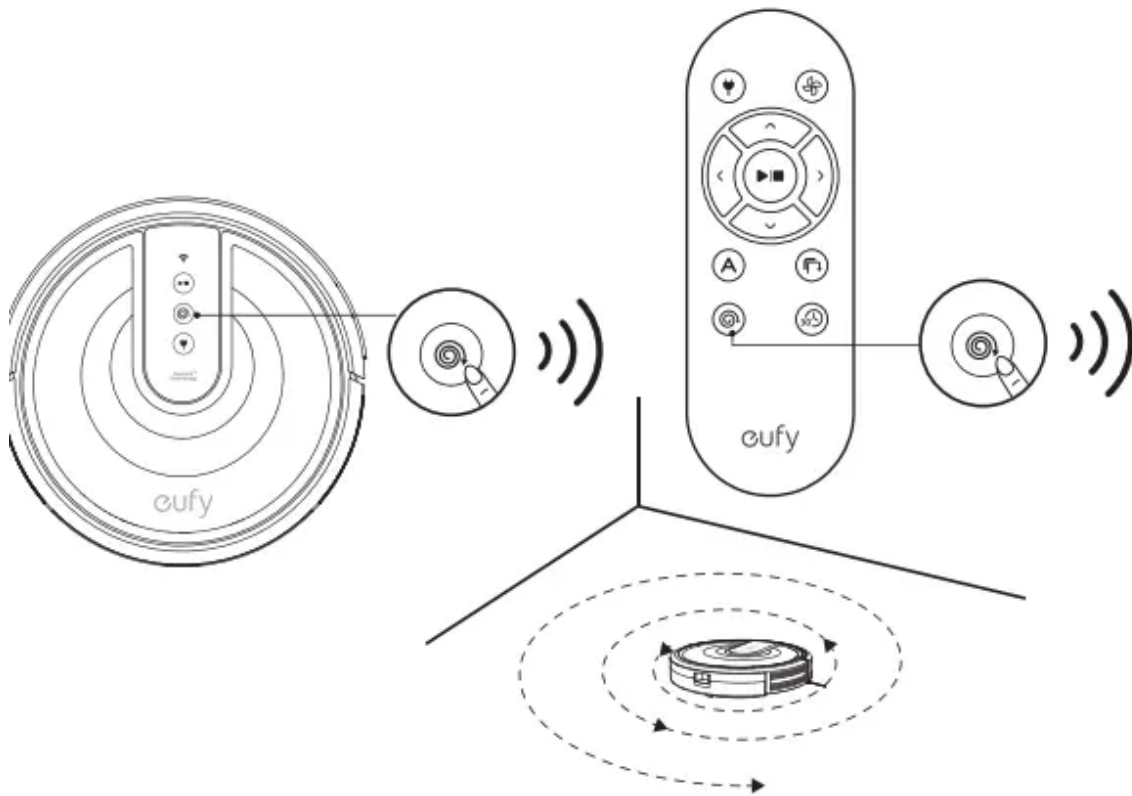

### 3. Edge cleaning

RoboVac reduces its speed when it detects a wall and then follows the wall to ensure the edge is cleaned thoroughly. In Edge mode, RoboVac will clean for 20 minutes and return to the Charging Base.

Press  on the remote control to start cleaning in Edge Mode.

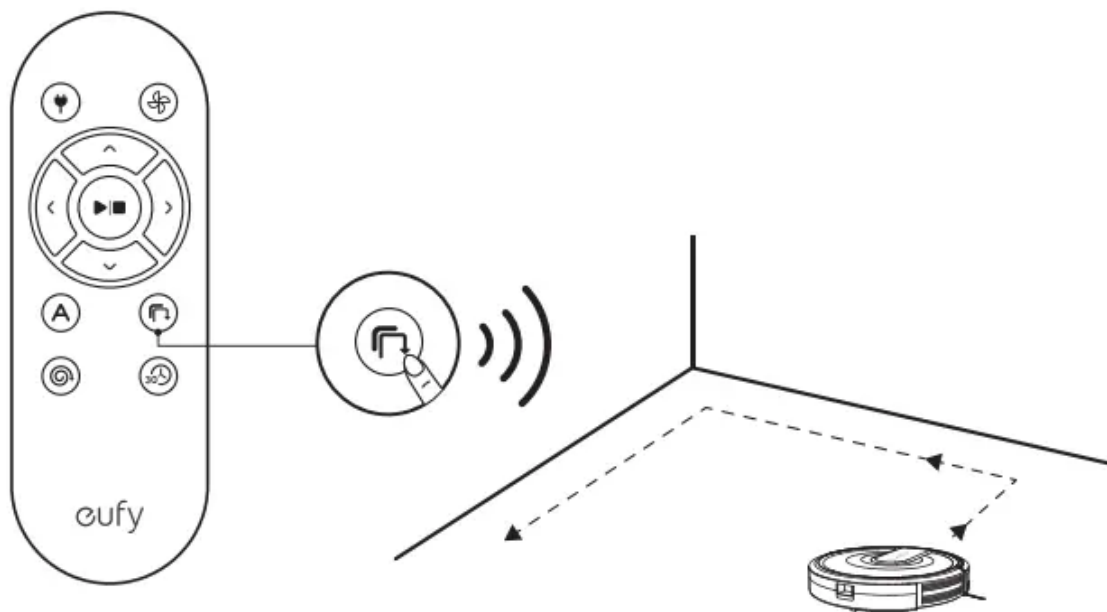

### 4. Quick cleaning

RoboVac will automatically stop cleaning after 30 minutes and return to the Charging Base in this mode. If any small room or area needs to be cleaned, it is recommended to select this mode to save time and power.

Press  on the remote control to start quick cleaning mode.

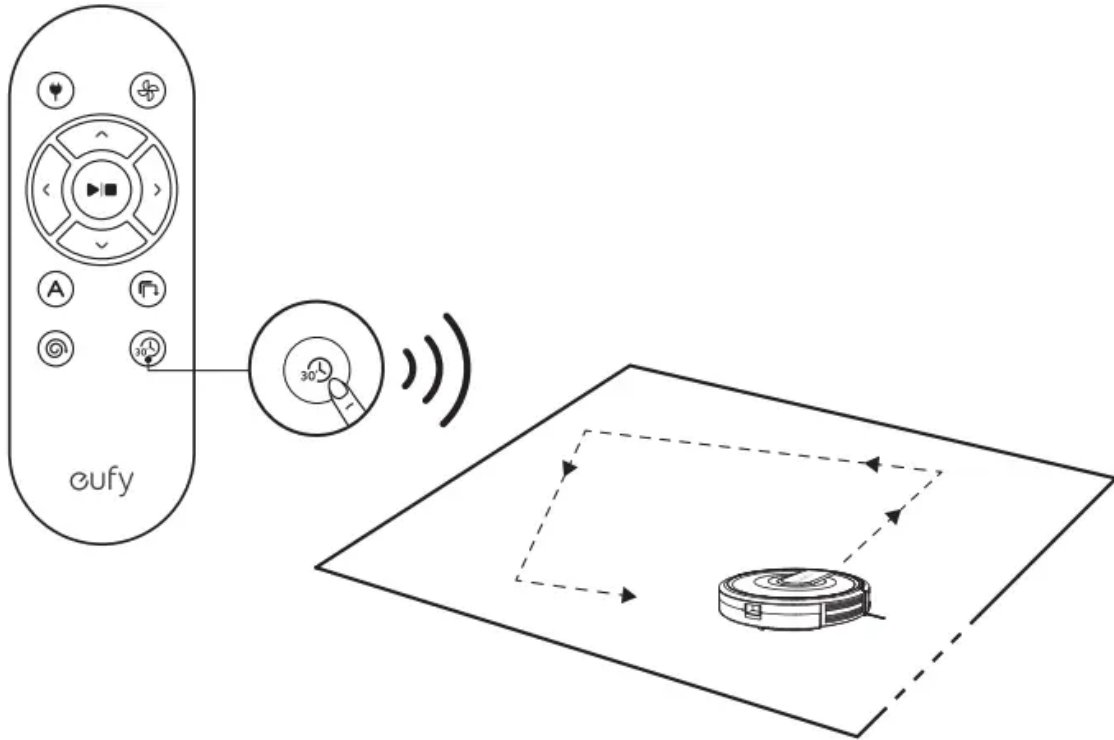

## 5. Manual cleaning

You can direct RoboVac to clean a particular area by using the directional buttons on the remote control.

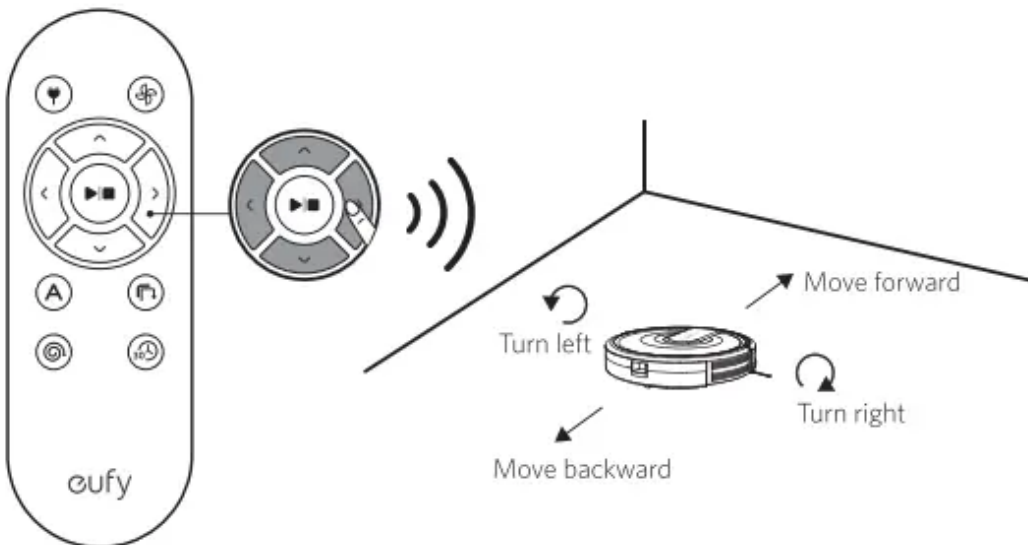

## Use the Boundary Strip (T2117 Only)

With the Boundary Strip, you can keep RoboVac away from any area or item you do not want RoboVac to clean. RoboVac will recognize the Boundary Strip and will not cross into the blocked-off area.

1. Identify the area or item you do not want RoboVac to get close to.
2. If necessary, use scissors to cut the Boundary Strip to a shorter length. Be sure to correctly measure the length before cutting.

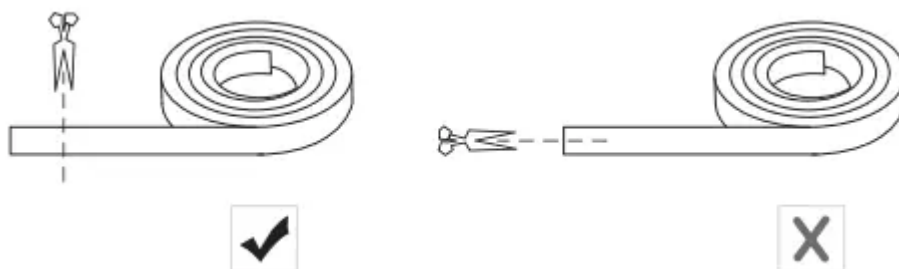

3. Apply the supplied strips of adhesive tape to lay the Boundary Strip flat on the floor. Make sure the strip is placed FLAT on the floor or under an area rug.

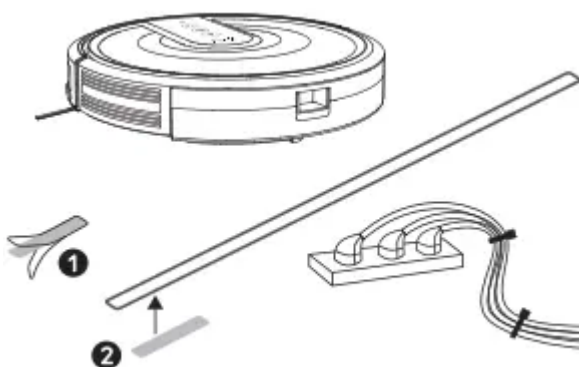

## Use Your RoboVac with Amazon Alexa / the Google Assistant

Amazon Alexa or the Google Assistant is a smart voice control device that enables you to control RoboVac with your voice.

### Before you start, make sure that:

- RoboVac is attached to the Charging Base to ensure there is enough power.
- RoboVac is connected with the EufyHome app.
- You have an Alexa-enabled device (i.e. eufy Genie, Amazon Echo, Echo Dot and Amazon Tap, Echo Show, Echo Spot) or a device enabled with the Google Assistant (i.e. Google Home, Google Home Mini). These devices are sold separately.
- The Amazon Alexa app or Google Home app is already installed on your smart device, and you have created an account.

Actual usage may be different from the instructions in this user manual due to updates of the Amazon Alexa and/or the Google Home app. Always follow the instructions in this app to connect to RoboVac.

### To control RoboVac with Amazon Alexa

The Amazon Alexa service is currently available in English and German only. More languages may be available later with the update of the service.

1. Open the Amazon Alexa app and select "Skills" from the  menu.
2. On the **Skills** screen, search for "EufyHome - RoboVac"
3. Once you have found the "EufyHome - RoboVac" skill, tap **Enable**.
4. Login with your EufyHome account so that Alexa can control your RoboVac.
5. Say simple commands to Alexa.

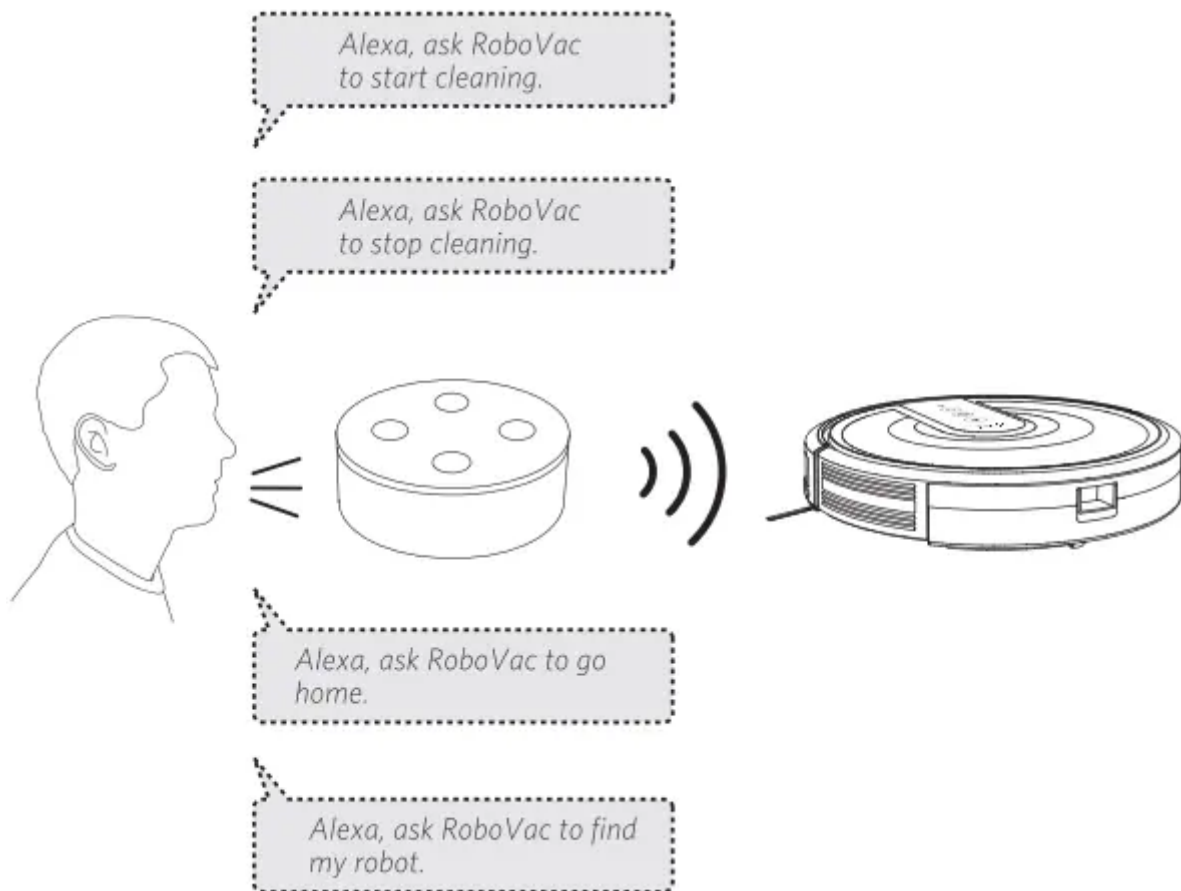

### To control RoboVac with the Google Assistant

RoboVac now works with the Google Assistant on devices like the Google Home.

The Google Assistant service is currently available in English and German only. More languages may be available later with the update of the service.

1. Open the Google Home app.

2. Say "Ok Google, talk to RoboVac" to the Google Assistant-enabled device to initiate the Google action for RoboVac.
3. Follow the instructions in the Google Home app to authorize the Google Assistant with your EufyHome account.
4. To control RoboVac with your voice, say simple commands to Google Assistant

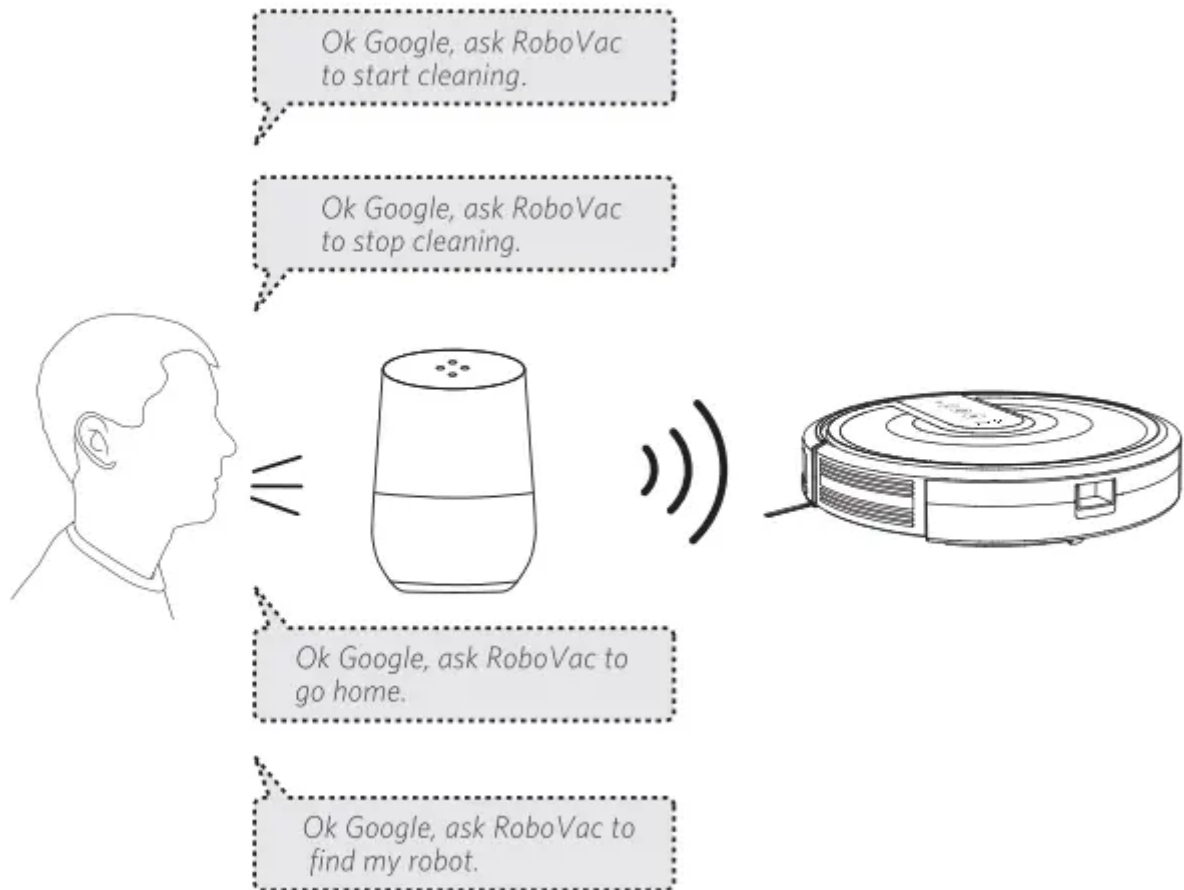

## Cleaning and Maintenance

### Recommended cleaning/replacement frequency

RoboVac Part	Cleaning Frequency	Replacement Frequency
Dust Collector	After each use	-
Filters	Once every week	Every 2 months
Rolling Brush	Once every week	Every 6-12 months
Side Brushes	Once every month	Every 3-6 months (or when visibly worn)
Brush Guard	Once every month	Every 3-6 months (or when the silicone rubber strip on the brush guard becomes visibly worn)
Sensors	Once every month	-
Charging Pins	Once every month	-
Swivel Wheel	Once every month	-

## Clean the Dust Collector and Filters

1 Press the dust collector release button to pull the dust collector out.

2 Open and empty the dust collector.

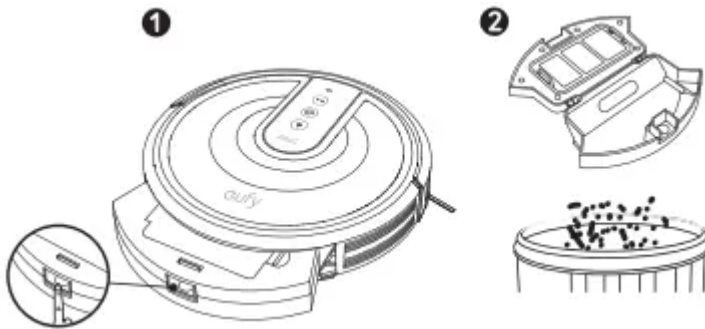

3 Remove the pre-filter by pulling the hooks as shown.

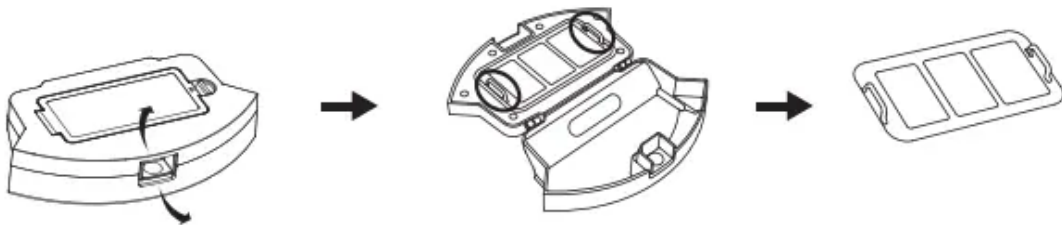

4 Take out the foam filter and high-performance filter.

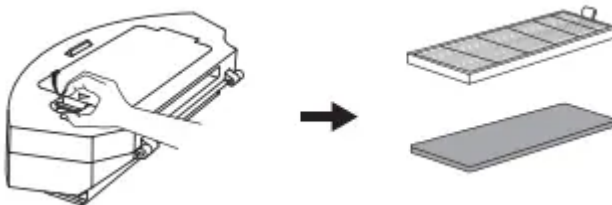

5 Clean the dust collector and filters with a vacuum cleaner or a cleaning brush.

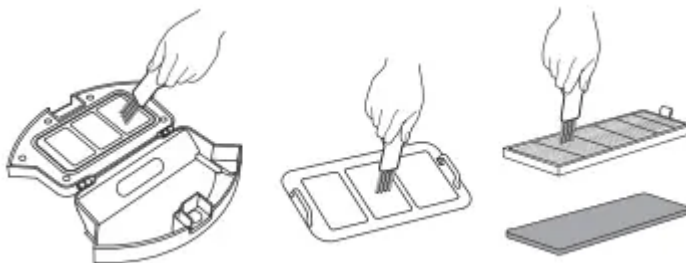

6 Put the filters and pre-filter back together in the dust collector.

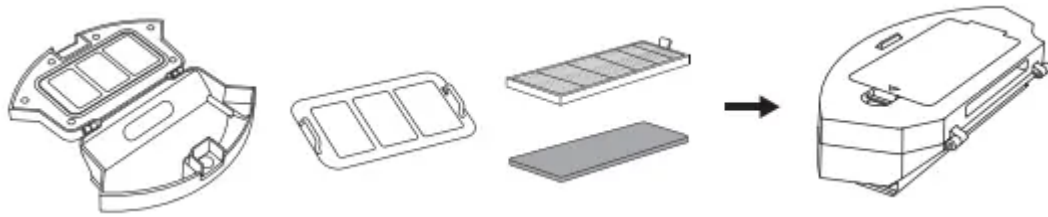

7 Push the dust collector back into the main unit.



## Clean the Rolling Brush

1. Pull on the release tabs to unlock the brush guard as shown.
2. Lift the rolling brush to remove
3. Clean the rolling brush with the provided cleaning tool or a vacuum cleaner.
4. Reinstall the rolling brush by inserting the fixed protruding end first and then clicking into place.
5. Press down to snap the brush guard into place.

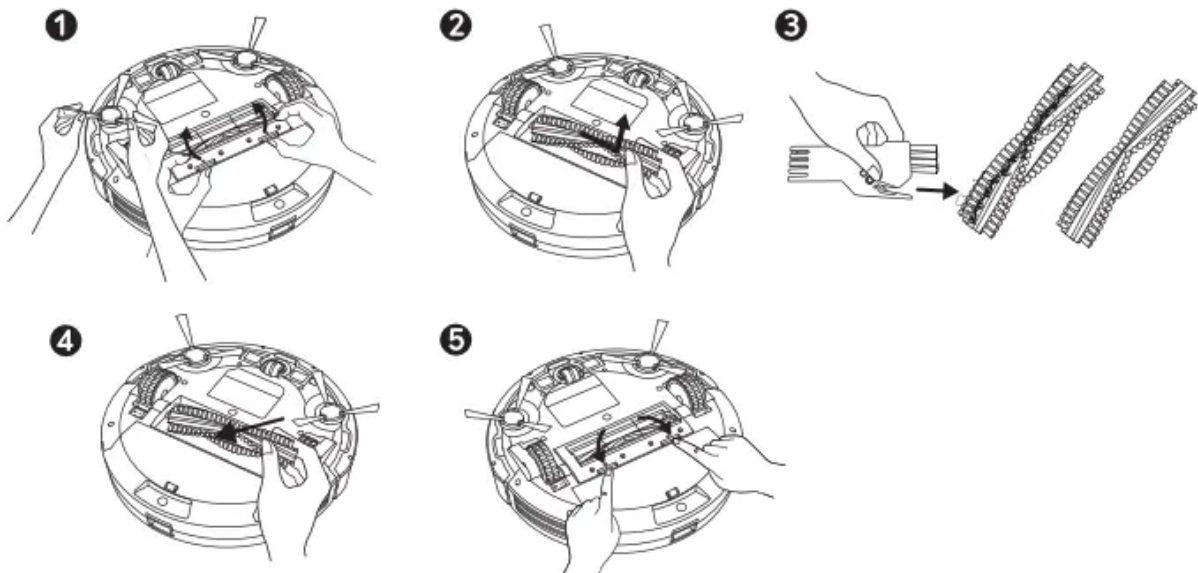

## Clean the Side Brushes

Foreign substances, such as hair, can easily get tangled in the side brushes, and dirt may adhere to them. Be sure to clean them regularly.

1 Remove the side brushes.

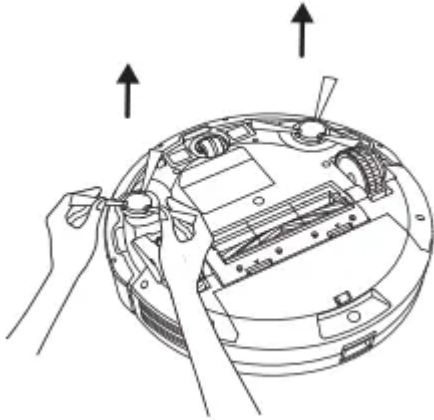

2 Carefully unwind and pull off any hair or string that is wrapped between the main unit and the side brushes.

3 Use a cloth dampened with warm water to remove dust from the brushes or to gently reshape them.

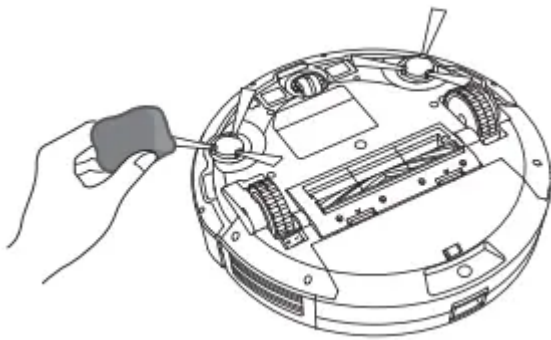

## Replace the Side Brushes

The side brushes may become bent or damaged after being used for a period of time. Follow the instructions below to replace them.

Pull off the old side brushes and snap the new ones into place.

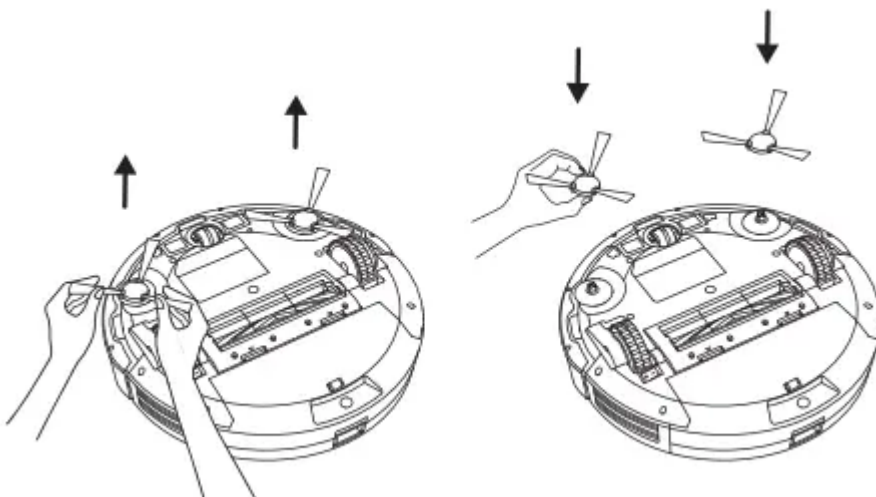

## Clean the Sensors and Charging Pins

To maintain the best performance, clean the drop sensors and charging pins regularly.

- Dust off the drop sensors and charging contact pins using a cloth or cleaning brush.

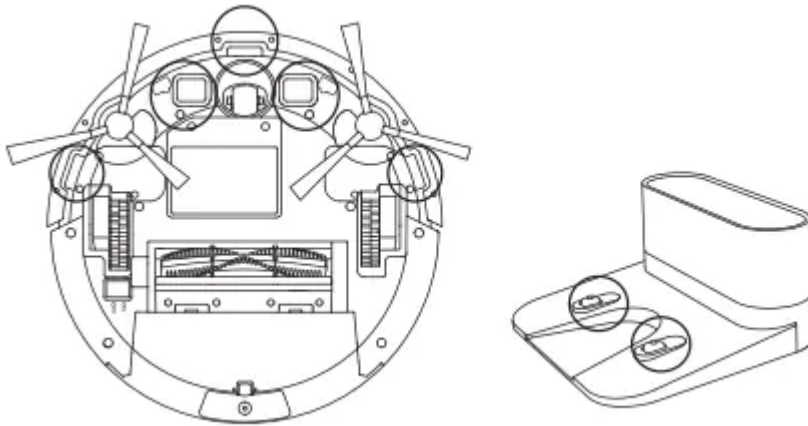

## Clean the Swivel Wheel

Hair or dust particles can easily get entangled in the swivel wheel. Be sure to clean the swivel wheel periodically and as needed.

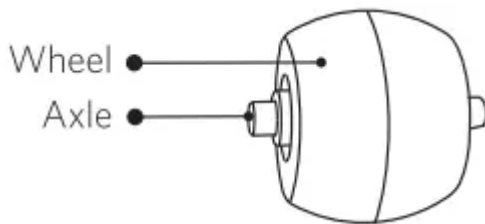

1 Pullout the swivel wheel

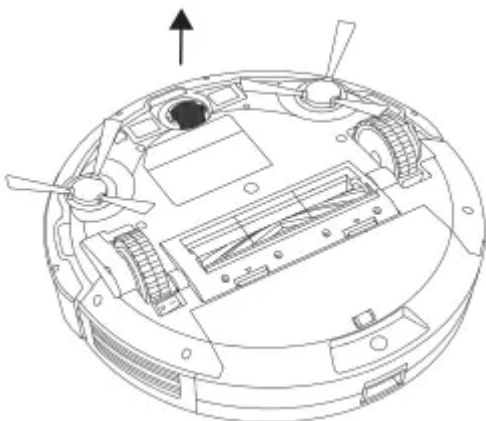

2 Clean any hair or debris wrapped around the wheel or entangled inside the wheel cavity.

3 Reinstall the wheel and push in until it clicks into place

## Troubleshooting

RoboVac cannot be activated

- Make sure the main power switch is in the ON position.
- Make sure the battery is fully charged.
- Replace the batteries (2 AAA) in the remote control.
- Make sure the remote control is within range (16 ft/5 m) of RoboVac.
- If you still have trouble, turn off the main power switch and then turn it back on

The remote control does not work.

- Replace the batteries in the remote control
- Make sure RoboVac is turned on and fully charged

RoboVac stops working suddenly

- Check if RoboVac is trapped or stuck on an obstacle.
- Check if the battery level is too low.
- If you still have trouble, turn off the main power switch, wait for 2 seconds, and then turn it back on.

You cannot schedule cleanings.

- Make sure the main power switch on the bottom of RoboVac is turned on.
- You can set the time of day and scheduled cleaning time via the EufyHome app.
- Make sure the scheduled time has been set correctly.
- Check if RoboVac's power is too low to start cleaning.
- Cleaning schedules are erased when RoboVac is powered off. If RoboVac is powered on without Internet access, cleaning schedules will not synchronize and must be reset via the app.

Suction power is weak.

- Check if any obstructions are blocking the suction inlet.
- Empty the dust collector.
- Clean the filters with a vacuum cleaner or a cleaning brush
- Check if the filters are wet due to water or other liquid on the floor. Air-dry the filters completely before use.

RoboVac cannot be charged

- Check if the indicator on the Charging Base lights up. If not, contact the eufy service center to repair or replace the Charging Base
- Dust off the charging contact pins with a dry cloth

- Check if you can hear a beep when RoboVac is docked onto the Charging Base. If not, contact the eufy service center to repair or replace the Charging Base.

RoboVac cannot return to the Charging Base.

- Remove objects within 3 ft/1 m to the left and right side and within 6 ft/2 m of the front of the Charging Base.
- When RoboVac is in the vicinity of the Charging Base, it will return more quickly. However, if the Charging Base is located far away. RoboVac will need more time to return. Please be patient as it works its way back.
- Clean the charging contact pins.

The rolling brush does not rotate.

- Clean the rolling brush.
- Check if the rolling brush and brush guard have been installed properly.

RoboVac's movements or travel path are abnormal.

- Clean the sensors carefully with a dry cloth
- Restart RoboVac by turning the power switch off and on

RoboVac cannot connect to a Wi-Fi network.

- Make sure your Wi-Fi router supports the 2.4GHz and 802.11b/g/n bands; the 5GHz band is not supported. For details, refer to the "**Troubleshooting > Wi-Fi connection**" section in this manual

You cannot control RoboVac with Amazon Alexa.

- Check if there are any Internet connection problems.
- Check whether you have installed the Amazon Alexa app onto your smart device and enabled "EufyHome - RoboVac" Skill in the Amazon Alexa app. For details, refer to the "**Use Your RoboVac with Amazon Alexa / the Google Assistant**" section in this manual
- Make sure you have an EufyHome account
- Make sure you are using correct Alexa voice-commands.
- The "EufyHome - RoboVac" Skill for Alexa is currently only available in English

You cannot control RoboVac with the Google Assistant.

- Check if there are any Internet connection problems.
- Check if you have installed the Google Home app onto your smart device and initiated the "EufyHome" action in the Google Home app. For detail, refer to the "**Use Your RoboVac with Amazon Alexa / the Google Assistant**" section in this manual.

- Check if you are using the proper commands when talking to the Google Assistant. When making your request, first say the wake words “Ok Google”.
- Repeat your question. Speak clearly to the Google Assistant.

## Error Tones

When RoboVac is in trouble, it will emit a series of short or long beeps and the red indicator on the  button will be solid or flashing.

### Flashing red indicator light

One beep

- Cause:
  - RoboVac is stuck and one of the wheels is not making contact with the floor (hanging in mid-air)
  - RoboVac may be in an extremely large room and the bumper is not registering obstacles
- Solution:
  - Restart cleaning in a new location

Two beeps

- Cause:
  - RoboVac's bumper is stuck.
- Solution:
  - Tap RoboVac's bumper several times to dislodge any debris that may be trapped underneath

Three beeps

- Cause:
  - RoboVac's drop sensors are dirty.
  - RoboVac is stuck on the ledge of a staircase and cannot reverse.
- Solution:
  - Clean the drop sensors gently with a dry cloth.
  - Place RoboVac in a new location.
  - Use a physical barrier to block off the problem area.

#### Four beeps

- Cause:
  - RoboVac's power level is too low.
- Solution:
  - Manually charge RoboVac for at least 5 hours.

#### **Solid red indicator light**

#### One beep

- Cause:
  - RoboVac's left/right wheel is stuck.
- Solution:
  - Turn off RoboVac and remove any hair or debris from the left/right wheel

#### Two beeps

- Cause:
  - RoboVac's side brush is stuck.
- Solution:
  - Turn off RoboVac and remove any hair or debris from the side brush.

#### Three beeps

- Cause:
  - RoboVac's suction fan is stuck.
- Solution:
  - Turn off RoboVac, then remove and empty the dust collector.
  - Make sure the suction inlet is not blocked by any hair or debris.

#### Four beeps

- Cause:
  - RoboVac's rolling brush is stuck.
- Solution:
  - Turn off RoboVac and remove any hair or debris from the rolling brush.

# Wi-Fi Setup Requirements

## RoboVac

- RoboVac is fully charged and the main power switch on the bottom of RoboVac is turned on.
- Wi-Fi status light slowly flashes blue.

## Wi-Fi Network

- Use the correct password for your network.
- Do not use a VPN (Virtual Private Network) or Proxy Server.
- Your Wi-Fi router supports 802.11b/g/n and IPv4 protocol.
- You are using a 2.4GHz router or a dual-band router that is configured to support a 2.4GHz frequency band. RoboVac does not support 5GHz frequency band.
  - If RoboVac cannot connect to the Wi-Fi network and you are using a 2.4/5GHz mixed network, switch to a 2.4GHz network for Wi-Fi setup. You can switch back once your setup is complete.
  - When connecting to a hidden network. make sure you enter the correct network name, SSID (case sensitive), and connecting to a 2.4GHz wireless network.
  - When using a network extender/repeater. make sure the network name (SSID) and password are the same as your primary network.
  - The firewall and port settings of your Wi-Fi router allow RoboVac to connect with the Eufy servers.

## Network Security Requirement

- WPA and WPA2 using TKIP. PSK. AES/CCMP encryption.
- WEP EAP (Enterprise Authentication Protocol) is not supported.

## Wi-Fi Channels

- The FCC requires that all wireless devices in the United States operate on the 1-11 wireless spectrum channels.
- Some countries outside North America can use spectrum channels higher than channel 11. Refer to your local regulatory agency to determine which channels are accessible.
- A future software release will support access to channels above 11 for users outside North America. Until then. use channels 1-11.

If you cannot control RoboVac with your smartphone. try the solutions below to solve the problem. If the problem persists. contact the eufy service center for help.

## Wi-Fi Status Light

### Solid blue

- Cause:
  - RoboVac has connected to your router, but cannot access the Internet.
- Solution:
  - Check if your router is connected to the Internet. Check with your Internet provider to see if there is any Internet connection problem.

### Rapidly flashing blue

- Cause:
  - RoboVac cannot connect to your wireless router.
- Solution:
  - Check if you have modified your network name and password.
  - Reset Wi-Fi connection if necessary. Refer to the "Use Your RoboVac with the EufyHome App > Reset the Wi-Fi connection" section in this manual.



### Slowly flashing blue

- Cause:
  - Wi-Fi connection is reset or has not been set up before.
- Solution:
  - Set up Wi-Fi connection with RoboVac. Refer to the "Use Your RoboVac with the EufyHome App" section in this manual.
  - Reset Wi-Fi connection if necessary. Refer to the "Use Your RoboVac with the EufyHome App > Reset the Wi-Fi connection" section in this manual.

### Off

- Cause:
  - RoboVac is turned off.
  - RoboVac's power level is low.
  - RoboVac is in Sleep mode.
- Solution:
  - Charge RoboVac by attaching it to the Charging Base. Make sure the main power switch on the bottom of RoboVac is turned on.

## Specifications

	Product Model	T2117 (RoboVac 35C) / T2123 (RoboVac 25C)
	Input	19 V  0.6 A
	Battery Voltage	DC 14.4 V
	Power Consumption	40 W
	Battery Type	DC 14.4 V Li-ion 2600 mAh
	Dust Collector Capacity	0.6 L
	Cleaning Time	Max. 100 mins
	Charging Time	300 - 360 mins

	Input	19 V  0.6 A
	Output	19 V  0.6 A

### Warning

This content is compiled from multiple sources and is provided for reference purposes only. It may not be complete or fully applicable to all situations. If you are unable to resolve your issue, please contact the product manufacturer or an authorized service provider for official support.