

User manual Microwave

Features

- 1,000 W of power quickly heats food
- Six presets easily cook your favorite foods
- 12.4-inch (31.5 cm) turntable helps evenly heat food
- Internal LED light shows your food
- Eleven power levels heat food to perfection
- Black plastic finish looks great with any décor
- Stylish blue LED display provides easy control

Package contents

- Countertop Microwave
- Turntable (with ring)
- User Guide

Microwave oven



#	ITEM	DESCRIPTION
1	Safety interlock system	Prevents the microwave from operating when the door is open.
2	Glass turntable	Allows food to cook evenly.
3	Control panel	Use to set cooking times and enter other information as needed.
4	Waveguide cover	Covers the waveguide. DO NOT REMOVE.
5	Turntable ring assembly	Allows the turntable to rotate to cook food evenly.
6	Turntable shaft	Rotates the turntable assembly.

Control panel

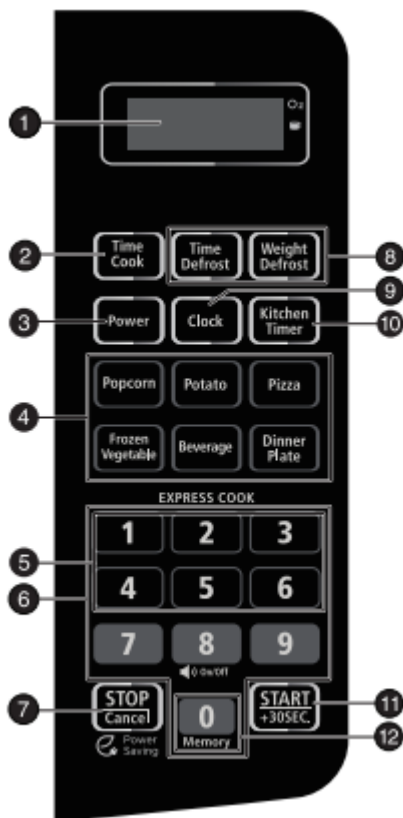

#	ITEM	DESCRIPTION
1	Display	In standby mode, displays the time. In cooking mode, displays cooking time, weight, and other information.
2	Time cook	Press to set the amount of time you want to heat your food, then press the number buttons to enter the time you want (up to 99 minutes and 99 seconds).
3	Power	Press to set the power level of your microwave, then press the number buttons to set the level you want (0-10).
4	Auto menu	Press one of these buttons to automatically cook the item indicated. See "Cooking with the auto menu" on page 9.
5	Express cook	In standby mode, press to quickly start cooking for 1 to 6 minutes. See "Cooking quickly" on page 9.
6	Number pad	Press to enter cook time, defrost time, clock time, and other information.
7	Stop/Cancel	Press to stop the cooking process. Press again to cancel the cooking operation.
8	Defrost	Press Time Defrost, then enter the time you want for an item to defrost. See "Defrosting by time" on page 10. Press Weight Defrost, then enter the weight of the item you want to defrost. The cooking time is set automatically. See "Defrosting by weight" on page 10.
9	Clock	Press to set or check the clock. See "Setting the clock" on page 8.
10	Kitchen timer	Press this button, then enter the time you want to count down. See "Using the kitchen timer" on page 9.
11	Start/Add 30 seconds	In standby mode, press this button to begin cooking. While cooking, press this button to add 30 seconds to cooking time.

12	Memory	Press repeatedly to choose a memorized procedure.
----	--------	---

Setting up your microwave oven

1. Remove all packing material, protective film, and accessories. Do not remove the light brown Mica cover that is attached to the oven cavity to protect the magnetron.
2. Check for any damage such as dents or a broken door. Do not use the microwave if it is damaged.
3. Select a level surface that provide enough open space for the vents:

CAUTION: Do not install the microwave over a range cooktop or other heat-producing appliance. Installing over a heat source can damage your microwave and will void your warranty.

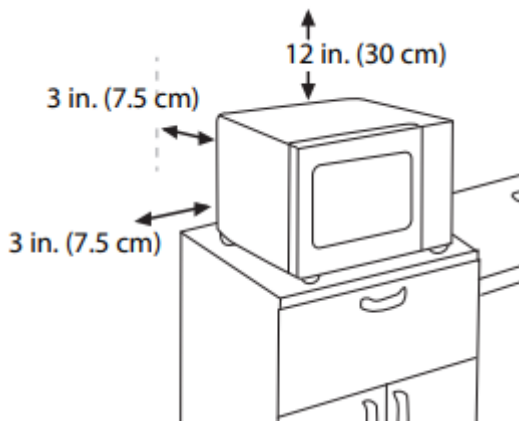

4. Plug your microwave into a power outlet.

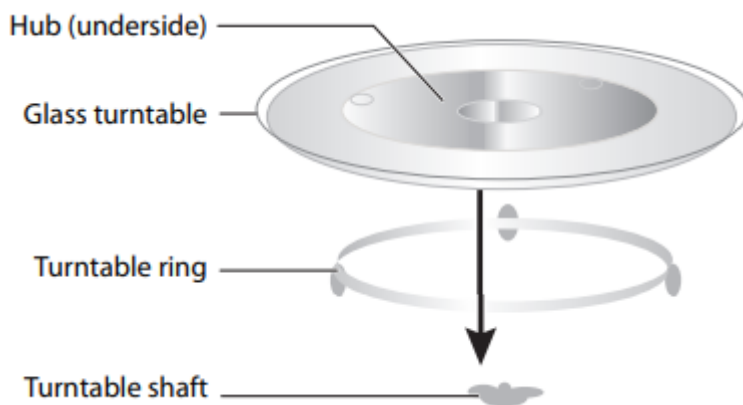

Notes:

- Never place the glass tray upside down. The glass tray should never be restricted.
- Both the glass tray and turntable ring must always be used during cooking.
- Always place all food and containers of food on the glass tray for cooking.

- If the glass tray or turntable ring cracks or breaks, contact your nearest authorized service center.
1. Place the turntable ring in the round depression in the bottom of the microwave oven so that it turns freely.
 2. Place the glass turntable (flat side up) on the turntable ring so that the hub engages the turntable shaft in the bottom of the oven. The glass turntable should not turn freely when it is correctly installed.

Setting the clock and the timer

Setting the clock

1. Press Clock. Your display shows “00:00”.
2. Use the number pad to enter the current time (1:00–12:59), then press Clock to save the setting. The colon (:) flashes to count the seconds and the clock is set.

Notes:

- While setting the clock, if you press STOP/Cancel or if you don’t press a button within one minute, the microwave will go back to its last setting.
- If the display shows “0:00”, the clock is not set.

Using the kitchen timer

1. Press Kitchen Timer. The display shows “00:00” and the first digit flashes.
2. Use the number pad to enter the time (up to 99 minutes and 99 seconds), then press START/+30SEC. When the time reaches 0, the buzzer rings.

Note: While the timer is running, the microwave will not run.

Cooking with your microwave

Microwave cooking

1. Press Time Cook, then use the number pad to enter the cooking time that you want.

Note: For example, to enter 3 minutes and 15 seconds, press 3, 1, and then 5.

2. Press Power, then enter the power level that you want (0-10). The default power level is 100% (PL10).

Level	10	9	8	7	6	5	4	3	2	1	0
Power	100%	90%	80%	70%	60%	50%	40%	30%	20%	10%	0%
Display	PL10	PL9	PL8	PL7	PL6	PL5	PL4	PL3	PL2	PL1	PL0

3. Press START/+30SEC to begin heating. The buzzer rings when the microwave is finished.

OR

For multi-stage cooking, repeat steps 1-2 to program the second stage, then press START/+30SEC. The buzzer will ring between stages and automatically move on to the second stage.

Note: Multi-stage cooking lets you program two cook times and power levels at the same time.

Cooking quickly

1. Press START/+30SEC to instantly cook something at 100% power for 30 seconds.

OR

Press 1-6 on the number pad to instantly cook something at 100% power for 1-6 minutes.

2. To increase the time in 30 second increments, press START/+30SEC repeatedly. The maximum cooking time is 99 minutes and 99 seconds.

Note: You cannot increase cook time when using multi-stage cooking, defrost, or auto-menu items.

Cooking with the auto menu

Popcorn

1. Press Popcorn repeatedly until the weight of your popcorn bag (1.75, 3.0, or 3.5 ounces) is shown on the display.
2. Press START/+30SEC to start. The buzzer sounds once, then cooks your popcorn.

Potato

1. Press Potato repeatedly until the number of potatoes you're cooking (1-3) is shown on the display.

Note: Each potato is assumed to be 8 oz. (227 g) If your potato is large, select the amount based on the potato's weight.

AMOUNT	WEIGHT (APPROX.)
1 potato	8 oz. (227 g)
2 potatoes	16 oz. (453 g)
3 potatoes	24 oz. (680 g)

2. Press START/+30SEC to start. The buzzer sounds once, then cooks your potato.

Frozen vegetables

1. Press Frozen Vegetable repeatedly until the number weight of your vegetables (4.0, 8.0, or 16.0 ounces) is shown on the display.
2. Press START/+30SEC to start. The buzzer sounds once, then cooks your vegetables.

Beverages

1. Press Beverage repeatedly until the number of cups (1-3) is shown on the display.
2. Press START/+30SEC to start. The buzzer sounds once, then heats your drink.

Dinner plate

1. Press Dinner Plate repeatedly until the weight of your food (9.0, 12.0, or 18.0 ounces) is shown on the display.
2. Press START/+30SEC to start. The buzzer sounds once, then heats your food.

Pizza

1. Press Pizza repeatedly until the weight of your food (4.0, 8.0, or 14.0 ounces) is shown on the display.
2. Press START/+30SEC to start. The buzzer sounds once, then heats your pizza.

Using a memorized procedure

Memorized procedures let you save heating operations (cook time and power level) that you use often. You must save a memorized procedure before using this feature. See “Saving a memory procedure” on page 10 for instructions.

- Press 0/MEMORY repeatedly to choose the memorized procedure that you want (1-3), then press START/ ADD 30SEC.

Defrosting in your microwave

Defrosting by weight

1. Press Weight Defrost. The display shows “dEF1”.
2. Use the number pad to enter the weight of the item to be defrosted (in ounces). The input weight must be between to 100 ounces.
3. Press START/+30SEC to start defrosting. The remaining cooking time is displayed.

Defrosting by time

1. Press Time Defrost. The display shows “dEF2”.
2. Use the number pad to enter the defrosting time you want. The time range must be between 00:01 and 99:99.
3. If you want to use the default power level (30%), skip to the next step. OR To change the power level, press Power, then use the number pad to enter the power level you want (0-10).
4. Press START/+30SEC to start defrosting. The remaining cooking time is displayed.

Changing other microwave settings

Using the child lock

- To lock the microwave, press and hold STOP/Cancel for three seconds while in standby mode. The microwave beeps and a box  appears on the display.

Note: The display won't show the time while the microwave is locked.

- To unlock the microwave, press and hold STOP/Cancel for three seconds until the microwave beeps then the display goes back to standby mode.

Muting your microwave

- To mute or unmute your microwave, press and hold the 8 button for three seconds while in standby mode. The microwave beeps and mutes or unmutes.

Note: No operations can make sound while the microwave is muted.

Using power saving mode

- While in standby mode, press STOP/Cancel briefly to turn off the display.

Checking the time or power level

- To check the time while cooking a meal, press Clock. The display shows the current time for three seconds, then returns to the cooking time remaining.
- To check the power level while cooking a meal, press Power. The display shows the power level being used for three seconds, then returns to the cooking time remaining.

Note: If you need to change the power level, cancel the cooking operation, then restart it.

Saving a memory procedure

Memorized procedures let you save heating operations (cook time and power level) that you use often. You can save up to three procedures. See "Using a memorized procedure" on page 10 to use a memorized procedure.

1. Press 0/Memory repeatedly to choose the memorized number (1-3) that you want to use.
2. Press Time Cook, then use the number pad to end the cook time that you want.

Note: For example, to enter 3 minutes and 15 seconds, press 3, 1, and then 5.

3. Press Power, then enter the power level that you want (1-10). The default power level is 100% (PL10).

Level	10	9	8	7	6	5	4	3	2	1	0
Power	100%	90%	80%	70%	60%	50%	40%	30%	20%	10%	0%
Display	PL10	PL9	PL8	PL7	PL6	PL5	PL4	PL3	PL2	PL1	PL0

4. (Optional) If you want to add a second stage, repeat steps 2-3. You can only add two stages to a memorized procedure.

5. Press START/+30SEC. The buzzer beeps and the display shows the memorized procedure number.

6. Press START/+30SEC again to run the procedure.

Note: If your microwave loses power, it will forget your memorized procedures.

Cleaning and maintaining your microwave

Cleaning the outside of your microwave

Exterior

The outside surface is precoated plastic. Clean the outside with mild soap and water, then rinse and dry with a soft cloth. Do not use any type of household or abrasive cleaner.

Door

Wipe the window on both sides with a damp cloth to remove any spills or splatters. Metal parts are easier to maintain if wiped frequently with a damp cloth. Avoid the use of spray and other harsh cleaners as they may stain, streak, or dull the door surface.

Control panel

If the control panel is dirty, open the microwave door before cleaning. Wipe the panel with a cloth dampened slightly with water only. Dry with a soft cloth. Do not scrub or use any sort of chemical cleaners. Close the door and press STOP/Cancel to clear any buttons you may have pressed.

Cleaning the inside of your microwave

Interior

Wipe with a soft cloth and warm water. Do not use abrasive or harsh cleaners or scouring pads. For baked-on food, use baking soda or a mild soap, then rinse thoroughly with hot water.

Waveguide cover

The waveguide cover is located on the side wall inside the microwave cavity. It is made from mica so requires special care. Keep the waveguide cover clean to assure good microwave performance. Carefully wipe with a damp cloth any food splatters from the surface of the

cover immediately after they occur. Built-up splashes may overheat and cause smoke or possibly catch fire. DO NOT REMOVE THE WAVEGUIDE COVER.

Removing odors

Occasionally, a cooking odor may remain in the microwave. To remove, combine one cup (.25 L) water, grated peel and juice of one lemon, and several whole cloves in a two-cup (.5 L) glass measuring cup. Boil for several minutes using 100% power, then let it cool in the microwave. Wipe the interior with a soft cloth.

Turntable

Remove the turntable and wash it in mild, sudsy water. For stubborn stains, use a mild cleanser and non-abrasive scouring sponge. You can also wash them in the top rack of a dishwasher.

The turntable motor shaft is not sealed, so excess water or spills should be wiped up immediately.

Troubleshooting

If you have a problem with your microwave, review the following chart for a possible solution. If the microwave still does not work properly, contact the nearest authorized service center.

PROBLEM	POSSIBLE CAUSE	POSSIBLE SOLUTION
Microwave will not start	The electrical cord is not plugged in.	Plug in the electrical cord.
	The door is open.	Close the door and try again.
	The wrong operation is set.	Check the instructions and try again.
Arcing or sparking in the microwave	You are attempting to use incorrect materials in the microwave.	Use only microwave-safe materials.
	You are attempting to use the microwave when it's empty	Do not operate the microwave when it's empty.
	Spilled food remains in the microwave.	Clean the microwave with a wet towel.
Unevenly cooked foods	You are attempting to use incorrect materials in the microwave.	Use only microwave-safe materials.
	The food is not defrosted completely.	Defrost the food completely before attempting to cook it.
	The cooking time or power level is not adequate to cook the food.	Use the correct cooking time and power level.
	The food is not turned or stirred.	Turn or stir the food.
Overcooked foods	The cooking time or power level is not adequate to cook the food.	Use the correct cooking time and power level.
Undercooked foods	You are attempting to use incorrect materials in the microwave.	Use only microwave-safe materials.

	The food is not defrosted completely.	Defrost the food completely before attempting to cook it.
	The cooking time or power level is not adequate to cook the food.	Use the correct cooking time and power level.
	The microwave ventilation ports are blocked or restricted.	Make sure that the ventilation ports are not blocked or restricted.
Improper defrosting	You are attempting to use incorrect materials in the microwave.	Use only microwave-safe materials.
	The cooking time or power level is not adequate to cook the food.	Use the correct cooking time and power level.
	The food is not turned or stirred.	Turn or stir the food.
The “:” colon on the display is blinking	This is normal behavior.	The colon blinks to count seconds when the clock is set.

Obtaining replacement parts

Call Insignia Customer Service at 1-877-467-4289.

IMPORTANT SAFETY INSTRUCTIONS

When using electrical appliances basic safety precautions should be followed, including the following:

WARNING: To reduce the risk of burns, electric shock, fire, injury to persons, or exposure to excessive microwave energy:

1. Read all instructions before using the appliance.
2. Read and follow the specific “Precautions to avoid possible exposure to excessive microwave energy” on page 4.
3. This appliance must be grounded. Connect only to a properly grounded outlet. See “Grounding instructions” on page 4.

4. Install or locate this appliance only in accordance with the provided installation instructions.
5. Some products such as whole eggs and sealed containers (for example, closed glass jars) are able to explode and should not be heated in this microwave.
6. Use this appliance only for its intended use as described in the manual. Do not use corrosive chemicals or vapors in this appliance. This type of oven is specifically designed to heat, cook, or dry food. It is not designed for industrial or laboratory use.
7. As with any appliance, close supervision is necessary when used by children.
8. Do not operate this appliance if it has a damaged cord or plug, if it is not working properly, or if it has been damaged or dropped.
9. This appliance should be serviced only by qualified service personnel. Contact the nearest authorized service facility for examination, repair, or adjustment.
10. Do not cover or block any openings on the appliance.
11. Do not store this appliance outdoors. Do not use this product near water - for example, near a kitchen sink, in a wet basement, near a swimming pool, or similar location.
12. Do not immerse the cord or plug in water.
13. Keep the cord away from heated surfaces.
14. Do not let the cord hang over the edge of the table or counter.
15. When cleaning the surface between the door and the compartment, use only mild, nonabrasive soaps, or detergent applied with a sponge or soft cloth.
16. To reduce the risk of fire in the oven cavity:
 - Do not overcook food. Carefully attend to the appliance when paper, plastic, or other combustible materials are placed inside the oven to facilitate cooking.
 - Remove wire twist-ties from paper or plastic bags before placing them in the oven.
 - If material inside of the oven ignites, keep the oven door closed, turn the oven off, and disconnect the power cord, or shut off power at the fuse or circuit breaker panel.
 - Do not use the cavity for storage purposes. Do not leave paper products, cooking utensils, or food in the cavity when not in use.
17. Liquids, such as water, coffee, or tea, may overheat beyond the boiling point without appearing to be boiling. Visible bubbling or boiling when the container is removed from the microwave oven is not always present. **THIS COULD RESULT IN VERY HOT LIQUID SUDDENLY BOILING OVER WHEN THE CONTAINER IS DISTURBED OR A UTENSIL IS INSERTED INTO THE LIQUID.** To reduce the risk of injury to persons:
 - Do not overheat the liquid.
 - Stir the liquid both before and halfway through heating it.

- Do not use straight-sided containers with narrow necks.
- After heating, allow the container to stand in the microwave oven for a short time before removing the container.
- Use extreme care when inserting a spoon or other utensil into the container.

18. As with any appliance, close supervision is necessary when the microwave oven is used by children.

19. If material inside of the oven should ignite, the oven door should be kept closed, the appliance turned off, the power cord disconnected, or the power shut off at the fuse or circuit breaker panel.

Grounding instructions

This appliance must be grounded. In the event of an electrical short circuit, grounding reduces the risk of electric shock by providing an escape wire for the electric current. This appliance is equipped with a cord having a grounding wire with a grounding plug. The plug must be plugged into an outlet that is properly installed and grounded.

1. A short power supply cord is provided to reduce the risks resulting from becoming entangled in or tripping over a longer cord.
2. Longer cord sets or extension cords are available and may be used if care is exercised in their use.
3. If a long cord or extension cord is used:
 - The marked electrical rating of the cord set or extension cord should be at least as great as the electrical rating of the appliance.
 - The extension cord must be a grounding-type 3-wire cord.
 - The longer cord should be arranged so that it will not drape over the counter top or tabletop where it can be pulled on by children or tripped over unintentionally

Radio interference

1. Operation of the microwave oven may cause interference to your radio, TV, or similar equipment.
2. When there is interference, it may be reduced or eliminated by taking the following measures:
 - Clean the door and sealing surface of the oven.
 - Reorient the receiving antenna of the radio or television.
 - Move the microwave oven away from the receiver.
 - Plug the microwave oven into a different outlet so that the microwave and receiver are on different branch circuits.
 - Relocate the microwave oven with respect to the receiver.

Precautions to avoid possible exposure to excessive microwave energy

1. Do not attempt to operate this oven with the door open since operation can result in harmful exposure to microwave energy. It is important not to defeat or tamper with the safety interlocks.
2. Do not place any object between the oven front face and the door or allow soil or cleaner residue to accumulate on sealing surfaces.
3. Do not operate the oven if it is damaged. It is particularly important that the oven door close properly and that there is no damage to the:
 - Door (bent)
 - Hinges and latches (broken or loosened)
 - Door seals and sealing surface
4. The oven should not be adjusted or repaired by anyone except properly qualified service personnel.

Warning

This content is compiled from multiple sources and is provided for reference purposes only. It may not be complete or fully applicable to all situations. If you are unable to resolve your issue, please contact the product manufacturer or an authorized service provider for official support.