

## Parts and Controls

### Controls and Indicators

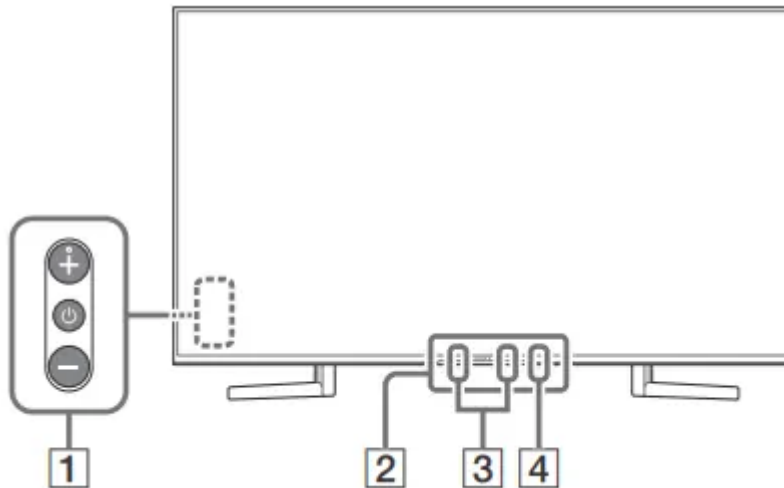

#### 1. (Power) / + / -

When the TV is off, Press to power on.

When the TV is on, Press and hold to power off. Press repeatedly to change the function, then press + or - button to:

- Adjust the volume.
- Select the channel.
- Select the input source of TV.

#### 2. Remote Control sensor / Light sensor / Illumination LED

The illumination LED lights up or blinks according to the status of the TV. For more information, refer to the Help Guide.

#### 3. Built-in MIC

Use the hands-free built-in microphone for the Google Assistant or voice search. To enable the built-in MIC, follow the on-screen instructions when you press the  button.

#### 4. Built-in MIC LED

The built-in MIC LED lights up in amber when the built-in MIC is enabled. The built-in MIC LED can be disabled.

# Using Remote Control

## Remote Control Parts Description

The remote control shape, location, availability and function of remote control buttons may vary depending on your region/country/TV model.

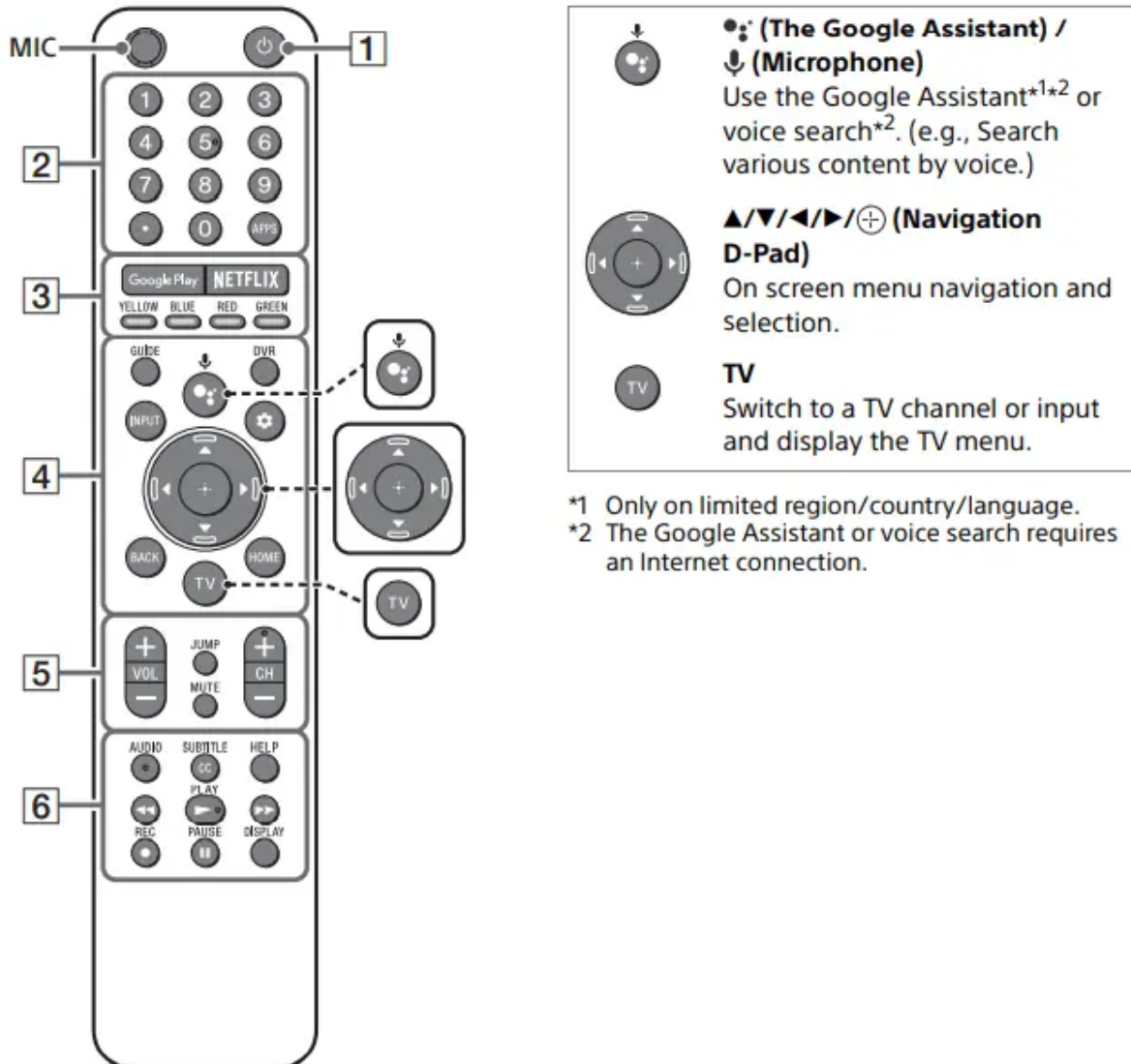

### 1. (TV standby)

Turn on or turn off the TV (standby mode).

### 2. Number buttons



Use with the 0-9 buttons to select digital channels.

### APPS

Display a list of installed apps.

### 3. Google Play

Access the “Google Play” online service.

#### **NETFLIX (Only on limited region/ country/TV model)**

Access the “NETFLIX” online service.

#### **Color buttons**

Execute corresponding function at that time.

### 4. GUIDE

Display the digital program guide, or EPG of cable/satellite box after setting [Cable/Satellite box setup].

#### **DVR**

Display the DVR’s list of recorded programs after setting [Cable/Satellite box setup].

#### **INPUT**

Display and select the input source, etc.

#### **(Quick settings)**

Display Quick Setting

#### **BACK**

Return to the previous screen.

#### **HOME**

Display the TV Home Menu.

### 5. VOL +/- (Volume)

Adjust the volume.

#### **JUMP**

Jump back and forth between two channels or inputs. The TV alternates between the current channel or input and the last channel or input that was selected.

#### **MUTE**

Mute the sound. Press again to restore the sound.

Hint

- The accessibility shortcut service can be turned on or off by pressing and holding MUTE.

#### **CH +/- (Channel)**

Select the channel.

### 6. AUDIO

Select the sound of multilingual source or dual sound for the program currently being viewed (depend on program source).



Operate media contents on the TV and connected BRAVIA Sync-compatible device.

### **SUBTITLE/CC**

Turn subtitles on or off (when the feature is available).

### **HELP**

Display the Help menu. Help Guide can be accessed from here.



Record the current program with the DVR after setting [Cable/Satellite box setup].

### **DISPLAY**

Display information about the channel/ program/input you are viewing.

## **Guidelines for IR Remote Control**

- Point your remote control directly at the IR sensor located on your TV.
- Make sure that no objects are blocking the path between the remote control and the IR sensor on your TV.
- Fluorescent lamps can interfere with your remote control; try turning off the fluorescent lamps.
- If you are having problems with the remote control, reinsert or replace your batteries and make sure that they are correctly inserted.

## **Connection Diagram**

For more information on connections, refer to the Help Guide by pressing HELP on the remote control.

### **Note**

- When connecting the cable to the Cable/Antenna input, finger tighten only, over tightening the connection can damage the TV.

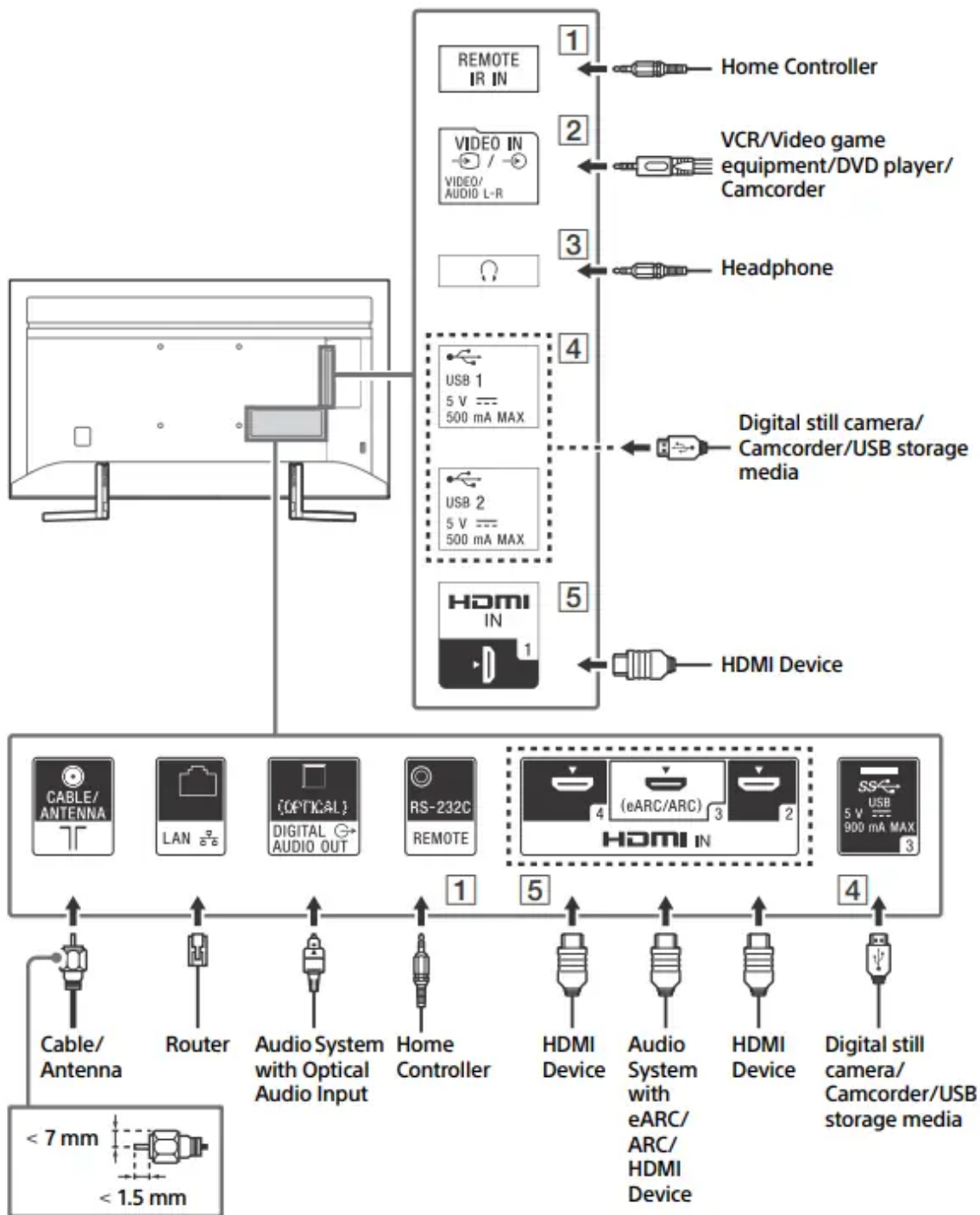

## 1. REMOTE RS-232C REMOTE IR IN

- These jacks are for receiving the external control signal. Enables extended control of the TV using RS-232C via the RS-232C and IR IN jacks. RS-232C: connect to the RS-232C terminal of the home controller. IR IN: connect to the IR out terminal of the home controller.
- Take care to not connect to headphones or an external audio system.

## 2. VIDEO IN

- For a composite connection, use an Analog Extension Cable (not supplied).

### 3. (Headphone)

- Supports 3-pole stereo mini jack only.
- You cannot output sound from both the headphone and the TV speakers at the same time

### 4 . USB 1/2, USB 3

- Connecting a large USB device may interfere with other connected devices beside it.
- When connecting a large USB device, connect to the USB 1 port.

### 5 HDMI IN 1/2/3/4

- HDMI interface can transfer the digital video and audio on a single cable.
- To enjoy high quality 4K 60p contents, connect a Premium High Speed HDMI cable and set the [HDMI signal format] to [Enhanced format]. Do this setting individually for each connected HDMI IN terminal. For details of supported formats, refer to the “Specifications” in this manual (page 16-17).

- **HDMI IN 3 eARC/ARC (Enhanced Audio Return Channel/Audio Return Channel)**

Connect your audio system to the HDMI IN 3 to route TV audio to your audio system. An audio system that supports HDMI eARC/ARC can send video to the TV, and receive audio from the TV via the same HDMI cable. If your audio system does not support HDMI eARC/ARC, an additional connection with DIGITAL AUDIO OUT (OPTICAL) is necessary.

- Use the HDMI cable with Ethernet to connect audio system with eARC.

## Installing the TV to the Wall

This TV's instruction manual only provides the steps to prepare the TV for Wall-Mount installation before it is installed on the wall.

Your TV can be mounted to a wall using a suitable Wall-Mount Bracket (not supplied). If the Table-Top Stand is attached to the TV, the TV may require detaching the Table-Top Stand; see page 13 (Detaching the Table-Top Stand from the TV). Prepare the TV for the Wall-Mount Bracket before making cable connections.

For product protection and safety reasons, Sony strongly recommends that installation of your TV on the wall be performed by qualified professionals. Do not attempt to install it yourself.

- Follow the instruction guide provided with the Wall-Mount Bracket for your model. Sufficient expertise is required in installing this TV, especially to determine the strength of the wall for withstanding the TV's weight.
- The screws for Wall-Mount Bracket are not supplied.
- The length of the screw for Wall-Mount Bracket differs depending on the Wall-Mount Bracket thickness. Please refer to below illustration.

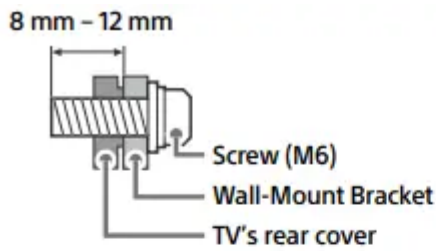

- Refer to the following table for wall-mount hole pattern.

Model Name	Wall-mount hole pattern
	a × b
XBR-85X950G	400 × 400 mm
XBR-75X950G	400 × 300 mm
XBR-65X950G XBR-55X950G	300 × 300 mm

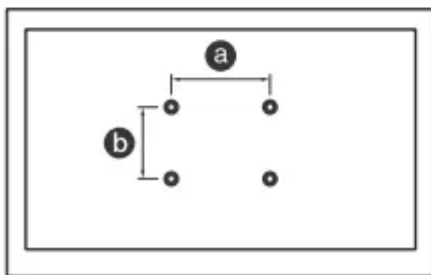

- Be sure to store the unused screws and Table-Top Stand in a safe place until you are ready to attach the Table-Top Stand. Keep the screws away from small children.

#### Note

- Read the supplied Safety Booklet for additional safety information.
- For more detailed information, visit Sony Customer Support website

#### 1. Remove the screws from the rear of the TV.

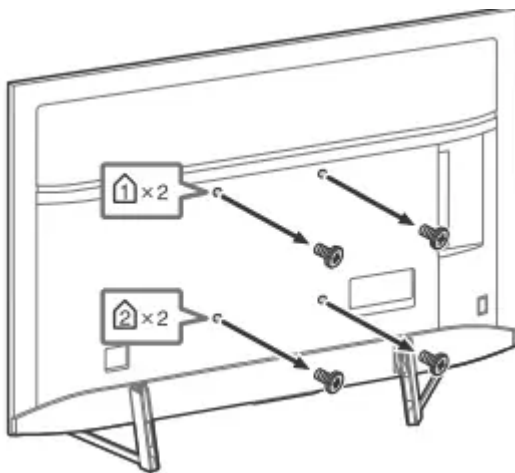

#### 2. Attach the Wall-Mount Bracket (not supplied) using the screws (not supplied).

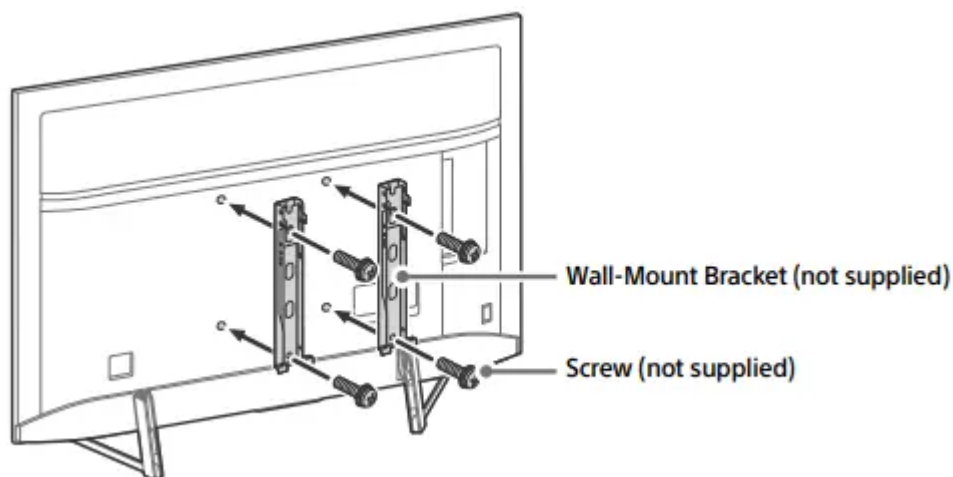

Note

- If using an electric screwdriver, set the torque at approximately 1.5 N·m {15 kgf·cm}

### Detaching the Table-Top Stand from the TV

To detach the Table-Top Stand from the TV, remove the screws .

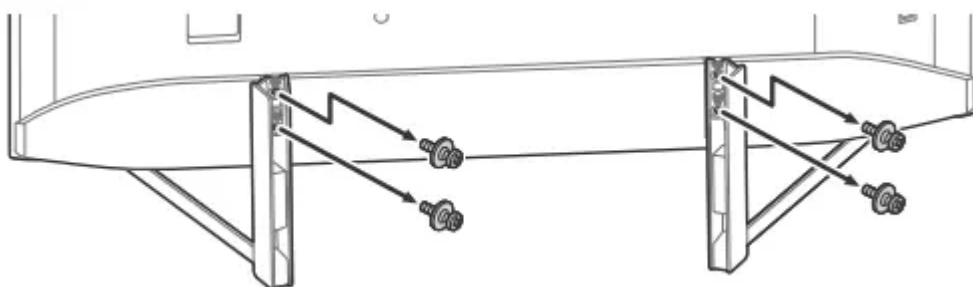

Note

- Be careful when lifting the TV as the Table-Top Stand is detached, the Table-Top Stand may topple over and cause personal injury.
- Take care when removing the Table-Top Stand from the TV to prevent it from falling over and damaging the surface that the TV is sitting on.
- Do not remove the Table-Top Stand for any reason other than to install corresponding accessories on the TV.
- Be sure the TV is vertical before turning on. To avoid uneven picture uniformity do not power on the TV with the panel facing down.
- When attaching the Table-Top Stand again, be sure to fasten the screws (previously removed) to the original holes on the rear of the TV

## Installing the TV against a wall or enclosed area

### Ventilation

- Never cover the ventilation holes or insert anything into the cabinet.
- Leave space around the TV set as shown below.

### Note

- Inadequate ventilation can lead to overheating of the TV and may cause damage to your TV or cause a fire.

## Troubleshooting

General troubleshooting for issues like: black screen, no sound, frozen picture, TV does not respond, or network is lost, do the following steps.

1. Restart your TV by pressing the power button on the remote control until a message appears. The TV will restart. If the TV does not recover, try unplugging the AC power cord. Then press the power button on the TV and wait for two minutes, and plug in the AC power cord.
2. Refer to the Help menu by pressing HELP on the remote control.
3. Connect your TV to the Internet and perform a software update. Sony recommends you to keep your TV software updated. Software updates provide new features and performance improvements.
4. Visit Sony support website (information provided on the front cover of this manual).
5. Perform the factory data reset. Refer to "How to reset the TV to factory settings"

**When you plug in the TV, the TV may not be able to turn on for a while even if you press the power button on the remote control or the TV.**

It takes time to initialize the system. Wait for about one minute, then operate it again.

### How to reset the TV to factory settings

**WARNING:** The reset will clear all of your customized settings including the parental lock setting.

- Turn on the TV. You can reset the TV to factory settings by selecting [Factory data reset]. How to select [Factory data reset], refer to the Help Guide.
- To force factory data reset, unplug the AC power cord. Press and hold both and – buttons on the TV, then plug in the AC power cord. Release both buttons when the illumination LED blinks in green.
- For security purposes, be sure to remove all personal and account information before discarding, selling or passing your TV to someone else by: unlinking/ unregistering, signing out of and deactivating all network services as well as factory reset the TV.

## Troubles and Solutions

### When the illumination LED is flashing in red.

- Count how many times it flashes (interval time is three seconds).

Reboot the TV by disconnecting the AC power cord from the TV until the illumination LED stopped flashing in red, then turn on the TV.

If the problem persists, disconnect the AC power cord, and contact Sony Customer Support (information provided on the front cover of this manual) with the number of times the illumination LED flashes.

### There is no picture (screen is dark) and no sound.

- Check the cable/antenna connection.
- Connect the TV to the AC power, and press the power button on the TV or the remote control.

### Some programs cannot be tuned.

- Check the cable/antenna connection.

### The remote control does not function.

- Replace the batteries.

### The parental lock password has been forgotten.

- Enter 4357 for the PIN and enter the new PIN.

### The restricted profile password has been forgotten.

- Perform the force factory data reset. Refer to “How to reset the TV to factory settings”

### The TV and its surroundings become warm.

- When the TV is used for an extended period of time, the TV and its surroundings may become warm to the touch. This is not a malfunction of the TV.

#### Warning

This content is compiled from multiple sources and is provided for reference purposes only. It may not be complete or fully applicable to all situations. If you are unable to resolve your issue, please contact the product manufacturer or an authorized service provider for official support.