

INSTALLATION GUIDE

1. Examine the oven after unpacking.

Check for damage such as a misaligned door, broken door or dent in the cavity. If any damage is visible, DO NOT INSTALL, and notify your dealer immediately.

2. Level, flat location.

Install the microwave oven on a level, flat surface.

3. Ventilation.

Do not block air vents. If they are blocked during operation, the oven may overheat and eventually cause a failure.

For proper ventilation, allow 4 inches of space between oven top, sides, rear and adjacent surfaces.

4. Away from radio and TV sets.

Poor television reception and radio interference may result if the oven is located close to a TV, radio, antenna, feeder, etc.

Place the oven as far from them as possible.

5. Away from heating appliances and water taps.

Keep the oven away from heat, steam or splashing liquids. These things can adversely affect oven wiring and contacts.

6. Power supply.

- Check your local power source.

This microwave oven requires a current of approximately 14 amperes, 120Volts, 60Hz and a grounded outlet.

1. A short power-supply cord is provided to reduce the risks of the user becoming entangled in or tripping over a longer cord.

2. Longer cord sets or extension cords are available and may be used if care is exercised in their use.

3. If a long cord or extension cord is used:

- The marked electrical rating of the cord set or extension cord should be at least as great as the electrical rating of the oven.
- The extension cord must be a grounding type 3-wire cord.

- The longer cord should be arranged so that it will not drape the table top or counter where it can be pulled on by children or tripped over unintentionally.

7. The minimum height of free space necessary above the top surface of the oven is about 4 inches.

When use 3-pronged plug

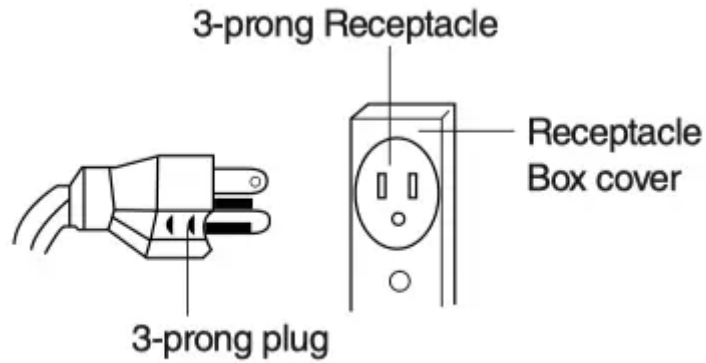

When use grounding adaptor, make sure the receptacle box is fully grounded.

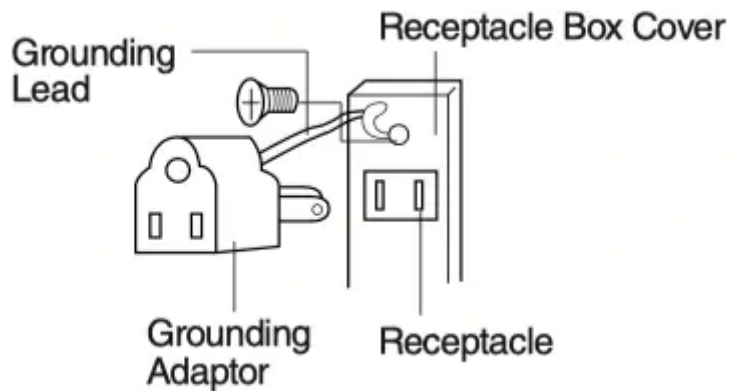

“THE CANADIAN ELECTRICAL CODE DOES NOT ALLOW THE USE OF THE GROUNDING ADAPTOR”

Specifications

POWER SUPPLY		120V AC, 60Hz SINGLE PHASE WITH GROUNDING
MICROWAVE	INPUT POWER	1550 W
	ENERGY OUTPUT	1100 W
	FREQUENCY	2,450MHz
OUTSIDE DIMENSIONS (W x D x H)		21.8 x 19.3 x 12.8 in.
CAVITY DIMENSIONS (W x D x H)		15.5 x 17.1 x 10.2 in.
CAVITY VOLUME		1.6 cu.ft
NET WEIGHT		APPROX. 35.3 lbs.
TIMER		95 min. 00 sec.
POWER SELECTIONS		11 Levels

* Specifications are subject to change without notice.

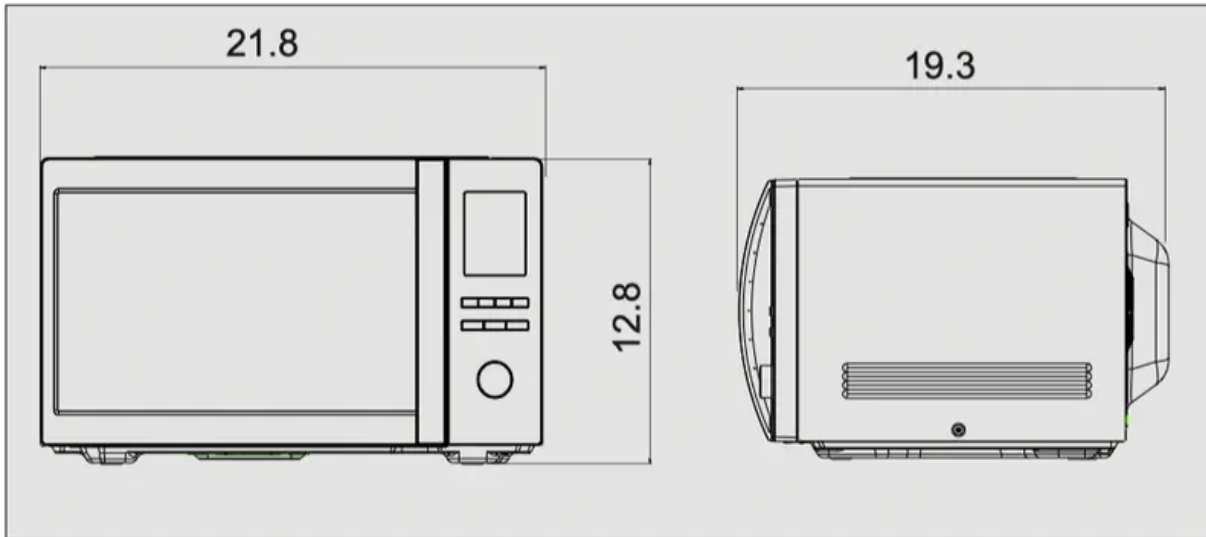

Features Diagram



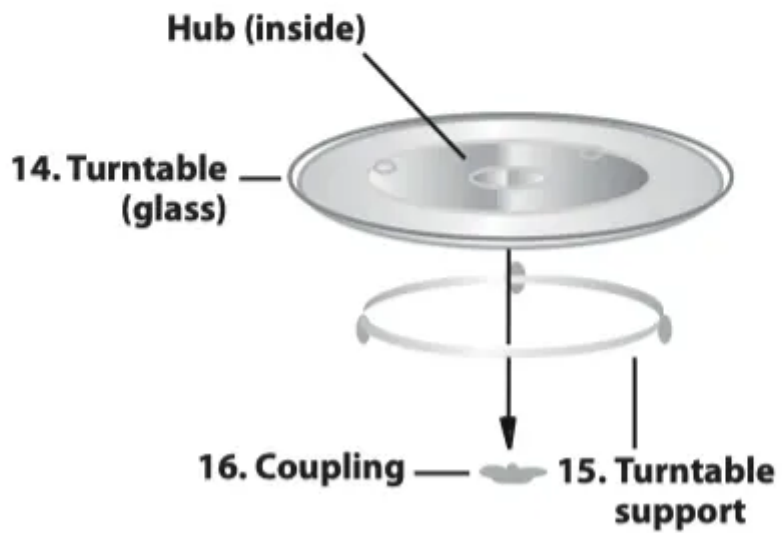
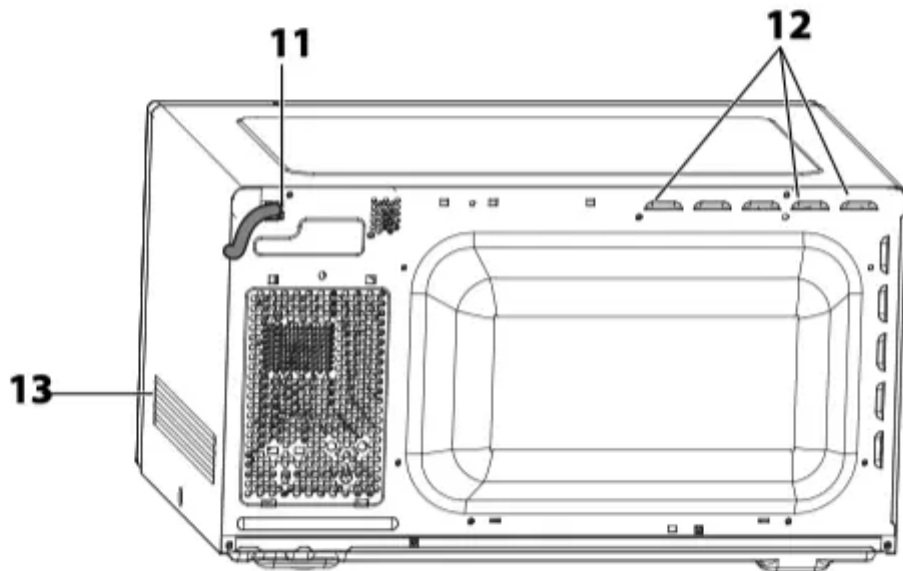
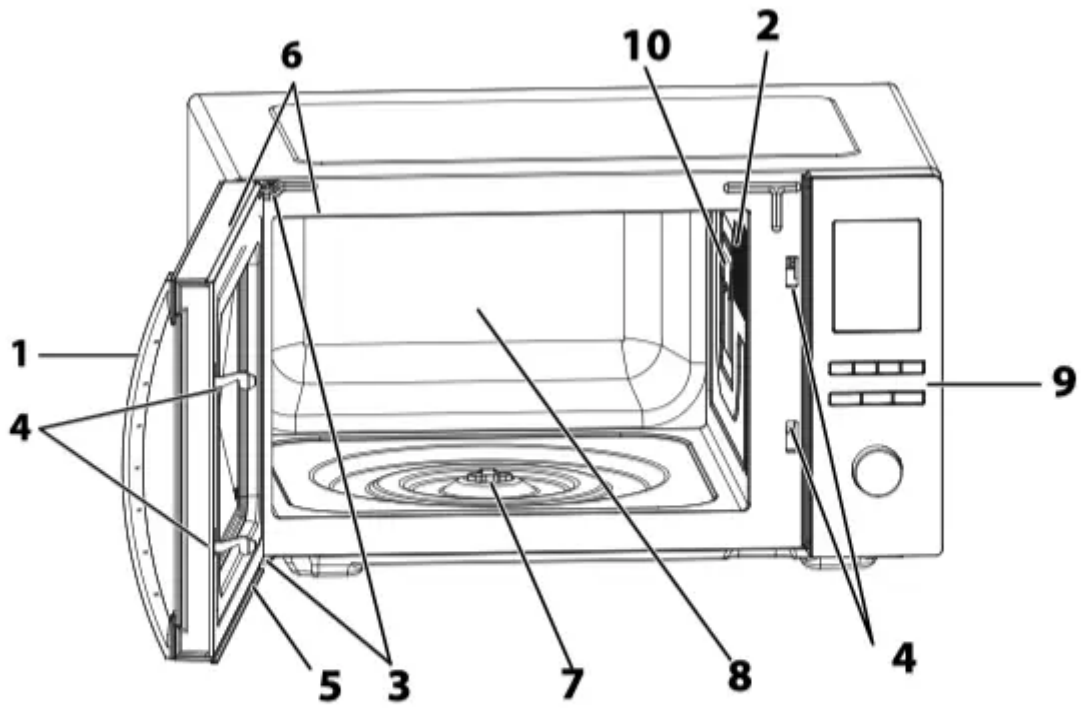

OVEN

1. Door handle
2. Oven lamp
3. Door hinges
4. Door safety latches
5. Door
6. Door seals and sealing surfaces
7. Turntable motor shaft
8. Oven cavity
9. Control panel
10. Waveguide cover (DO NOT REMOVE)
11. Power supply cord
12. Ventilation openings
13. Outer cabinet

ACCESSORIES:

Check to make sure the following accessories are provided:

(14) Turntable (15) Turntable support (16) Coupling Place the coupling into the turntable motor shaft and then place the turntable support in the center of the oven floor so that it can freely rotate around the coupling. Place the turntable onto the turntable support so that it locates firmly into the coupling. To avoid turntable damage, ensure dishes and containers are lifted clear of the turntable rim when removing them from the oven.

NOTE: When you order accessories, please mention two items: part name and model name to your dealer or SHARP authorized service agent.

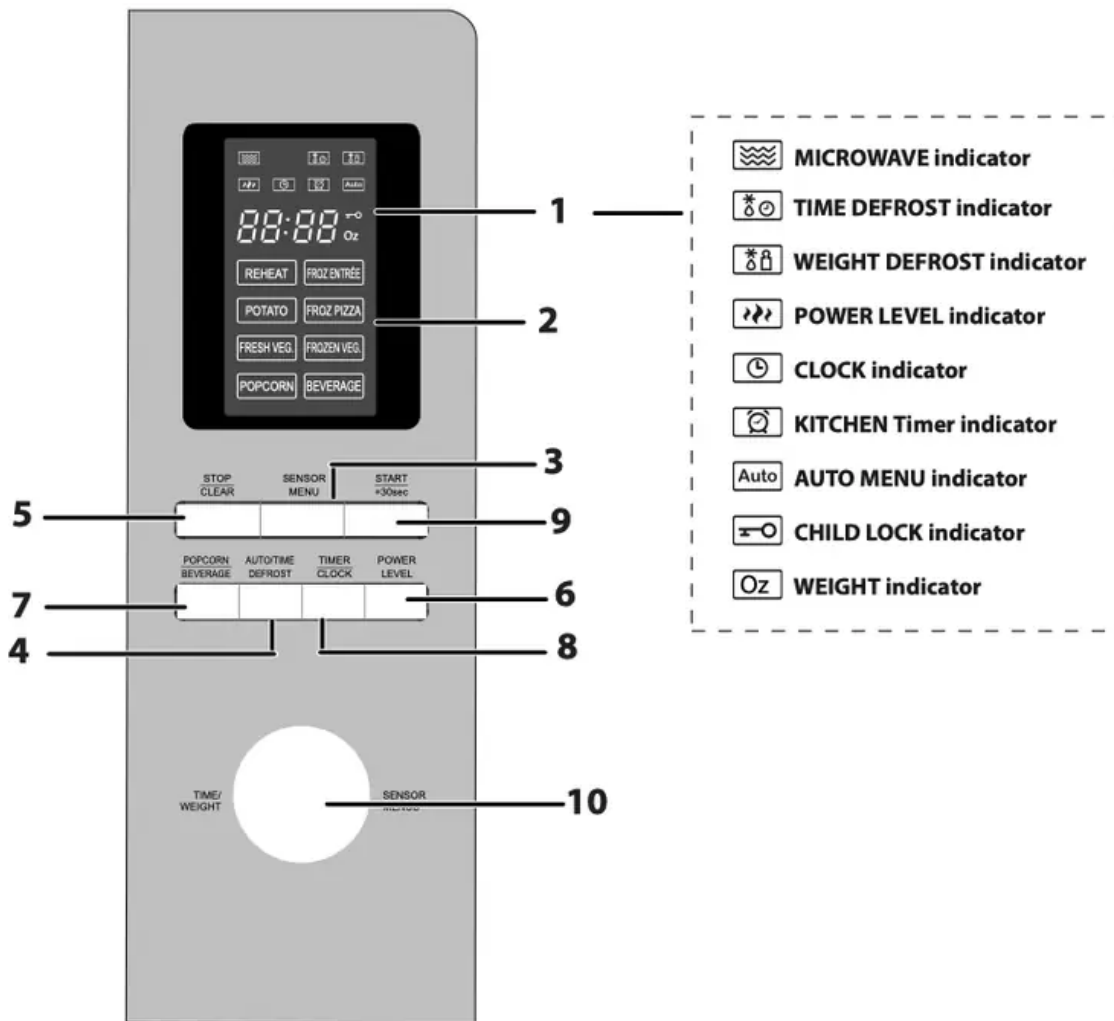

1. DIGITALDISPLAY and INDICATORS

2. MENU options Reheat, Frozen Entree , Potato ,Fresh Vegetable, Frozen Vegetable Beverage, Frozen Pizza Popcorn.

3. SENSOR MENU button

4. AUTO/TIME DEFROST button

5. STOP/CLEAR button

6. POWER LEVEL button

7. POPCORN/BEVERAGE button

8. TIMER/CLOCK button

9. START/ +30sec. button

10. ENTRY dial (Time/Weight/Sensor menu dial) Rotate to enter the cooking time, power level, weight and select sensor menus.

NOTE: ENTRY DIAL can be push in to hide it.

Operation Procedure

This section includes useful information about oven operation.

1. Plug power supply cord into a standard 3-pronged 14 Amp, 120V AC 60Hz power outlet.
2. After placing the food in a suitable container, open the oven door and put it on the glass tray. The glass tray and roller guide must always be in place during cooking.
3. Close the door. Make sure that it is firmly closed.
4. The oven light is on when the microwave oven is operating.
5. The oven door can be opened at any time during operation by pull the door handle. The oven will automatically shut off.
6. Each time a key is touched, a BEEP will sound to acknowledge the touch.
7. The oven automatically cooks on full power unless set to a lower power level.
8. The display will show " 0:00" when the oven is plugged in.
9. Time clock returns to the present time when the cooking time ends.
10. When the STOP/CLEAR key is touched during the oven operation, the oven stops cooking and all information retained. To erase all information(except the present time), touch the STOP/CLEAR key once more. If the oven door is opened during the oven operation, all information is retained.
11. If the START key is touched and the oven does not operate, check the area between the door and door seal for obstructions and make sure the door is closed securely. The oven will not start cooking until the door is completely closed or the program has been reset.

Make sure the oven is properly installed and plugged into the electrical outlet.

Wattage output chart

- The power-level is set by touching the Power Level key. The chart shows the display, the power level and the percentage of power.

TOUCH THE POWER KEY	POWER LEVEL (DISPLAY)	A PPRO x IMATE PERCENTAGE OF POWER
Once	P100	100%
twice	P90	90%
3 times	P80	80%
4 times	P70	70%
5 times	P60	60%
6 times	P50	50%
7 times	P40	40%
8 times	P30	30%
9 times	P20	20%
10 times	P10	10%
11 times	P0	0%

Controls

SETTING THE CLOCK

Your oven has a 12 hour clock feature.

1. Press the TIMER/CLOCK button twice. The hour figure will flash and the clock indicator will illuminate.
2. Rotate the ENTRY dial until the correct hour is displayed, the input time should be within 12.
3. Press the TIMER/CLOCK button, the minute figure will flash.

4. Set the minutes. Rotate the ENTRY dial until the correct minutes are displayed, the input time should be within 0-59.

5. Press the TIMER/CLOCK button to start the clock. The icon ":" of the digital time will be flashing on the display and the clock indicator will disappear.

Example:

To set the clock to 5:05.

1. Press TIMER/CLOCK twice.

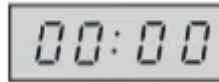

2. Rotate ENTRY dial to select hour figure .



3. Press TIMER/CLOCK, once.

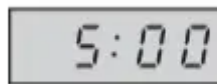

4. Rotate ENTRY dial to select minute figure .



5. Press TIMER/CLOCK to confirm the setting.

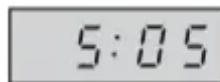

NOTES:

- If the clock is set, when cooking is complete, the display will show the correct time of day. If the clock has not been set, the display will show "0:00".
- To check the time of day during a cooking process, press TIMER/CLOCK button and the LED will display the time of day for 2-3 seconds. This does not affect the cooking process.
- If in the process of setting the clock, the STOP/CLEAR button is pressed, the oven will revert back to the former setting.
- If the electrical power supply to your microwave oven is interrupted, the display will intermittently show "0:00" after the power is reinstated. If this occurs during cooking, the programme will be erased. As will the time of day.

+30sec FUNCTION / DIRECT START

Direct start

You can directly start cooking at 100% microwave power level for 30 seconds by pressing the START/ +30sec. button. The cooking process will start immediately and each time the button is pressed this will increase the cooking time by 30 sec.

NOTE: The cooking time may be extended to a maximum of 95 minutes.

TIME COOKING

1. Rotate ENTRY dial either direction to increase or decrease the cooking time .



2. Press the START/+30sec key to start cooking.

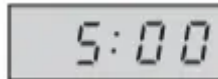

Your oven can be programmed for up to 95 minutes (95:00). The input unit of cooking /defrosting time varies from 5 seconds to 95 minutes. It depends on the total length of the cooking/defrosting time as shown on the table.

Cooking Time	Increasing Unit
0-1 minute	5 seconds
1-5 minutes	10 seconds
5-10 minutes	30 seconds
10-30 minutes	1 minute
30-95 minutes	5 minutes

POPCORN MENU

Example: To use the popcorn menu weighing 3.5 oz using POPCORN MENU.

Use only containers that are microwave-safe .

1. Press the POPCORN/BEVERAGE button once.

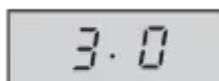

2. Enter the desired weight by rotating the ENTRY dial until the display shows:

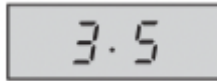

3. Press the START/+30sec. button to start cooking.

(The display will count down through cooking time)

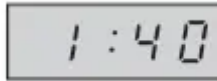

BEVERAGE MENU

Example: To use the beverage menu weighing 3 cups using BEVERAGE MENU.

Use only containers that are microwave-safe .

1. Press the POPCORN/BEVERAGE button twice.

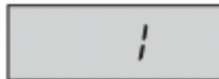

2. Enter the desired cups by rotating the ENTRY dial until the display shows:

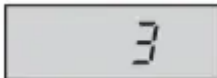

3. Press the START/+30sec. button to start cooking.

(The display will count down through cooking time)

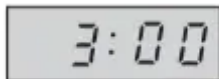

AUTO DEFROST FUNCTION

AUTO DEFROST

The microwave oven is pre-programmed with a timer and power levels so that foods such as pork, beef and chicken can be easily defrosted. The weight range for this is from 1 – 100 ounces.

Follow the example below for details on how to operate this function.

Example: To defrost meat weighing 12 oz using AUTO DEFROST.

Use only containers that are microwave-safe .

1. Press the AUTO/TIME DEFROST button once.

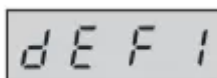

2. Enter the desired weight by rotating the ENTRY dial until the display shows:

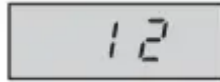

3. Press the START/+30sec. button to start defrosting.

(The display will count down through defrosting time)

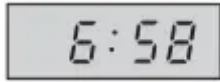

NOTE:

- Frozen foods are defrosted from 0°F.
- Before freezing foods, ensure food is fresh and of good quality.
- If necessary, shield small areas of meat or poultry with flat pieces of aluminium foil. This will prevent the areas from becoming warm during defrosting. Ensure the foil does not touch the oven walls.
- Food weight should be rounded up to the nearest 1 Oz , for example, 6.5 Oz to 7 Oz .
- After defrosting an audible signal will sound five times and the LED will then display time of day, if the clock has been set. If the clock has not been set, the display will only show "0:00" when defrosting is complete.

TIME DEFROST FUNCTION

TIME DEFROST

This function quickly defrosts food while enabling you to choose a suitable defrost period, depending on the food type. Follow the example below for details on how to operate this function. The time range is 0:05 – 95:00.

Example: To defrost food for 10 minutes.

1. Press the AUTO/TIME DEFROST button twice.

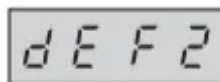

2. Enter the cooking time by rotating the ENTRY dial until the display shows: 10:00

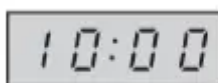

3. Press the START/ +30sec. button to start defrosting.

(The display will count down through defrosting time)

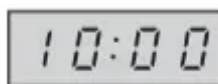

Notes for Time Defrost:

- The preset microwave power level can not be changed.
- Before freezing foods, ensure food is fresh and of good quality.
- If necessary, shield small areas of meat or poultry with flat pieces of aluminium foil. This will prevent the areas from becoming warm during defrosting. Ensure the foil does not touch the oven walls.
- After defrosting an audible signal will sound five times and the LED will then display the time of day, if the clock has been set. If the clock has not been set, the display will only show "0:00" when defrosting is complete.

MICROWAVE FUNCTION

- Press the POWER LEVEL button once, P100 will be displayed and at the same time the microwave indicator and power level indicator will illuminate on the display.
- Press POWER LEVEL or rotate the ENTRY dial to change the power level until the display indicates the desired level.
- Press the START/+30sec. button to confirm the setting, rotate the ENTRY enter the cooking time and then press the START/ +30sec. button again to start the oven.
- To check the power level during cooking, press the POWER LEVEL button, the current power level will be displayed for 3 seconds. The oven will continue to count down although the display will show the power level.
- If "P0" is selected, the oven will work with the fan but no power. You can use this level to remove the odor.

Generally the following recommendations apply:

P100/ P90 - (HIGH) used for fast cooking or reheating e.g. for casseroles, hot beverages, vegetables etc.

P80/ P70 - (MEDIUM HIGH) used for longer cooking of dense foods such as roasts, meat loaf and plated meals, also for sensitive dishes such as sponge cakes.

At this reduced setting, the food will cook evenly without over cooking at the sides.

P60/ P50 - (MEDIUM) for dense foods which require a long cooking time when cooked conventionally, e.g. beef casserole, it is advisable to use this power setting to ensure the meat will be tender.

P40/ P30 - (MEDIUM LOW) to defrost, select this power setting, to ensure that the dish defrosts evenly. This setting is also ideal for simmering rice, pasta, dumplings and cooking egg custard.

P20/ P10 - (LOW) For gentle defrosting, e.g. cream gateaux or pastry.

Power Level	Press the POWER LEVEL key	Display (Percentage)
HIGH	x1	P100
	x2	P90
MEDIUM HIGH	x3	P80
	x4	P70
MEDIUM	x5	P60
	x6	P50
MEDIUM LOW (DEFROST)	x7	P40
	x8	P30
LOW	x9	P20
	x10	P10
	x11	P0

Example:

To cook for 2 minutes and 30 seconds on P80 (80%) microwave power.

1. Press the POWER LEVEL button. P100 will be displayed.

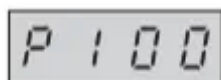

2. Rotate the ENTRY dial to select the power level for P80.

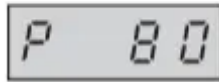

3. Press the START/ +30sec. button to confirm the setting.

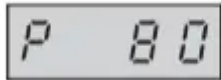

4. Enter the cooking time by rotating the ENTRY dial.

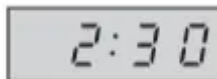

5. Press the START/ +30sec. button to start cooking. (The display will count down through the programmed cooking time.)

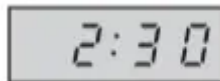

NOTE:

- When the oven starts, the oven lamp will illuminate and the turntable will rotate clockwise or counterclockwise.
- If the door is opened during cooking/defrosting to stir or turn over food, the cooking time on the display will stop automatically. The cooking/defrosting time starts to count down again when the door is closed and the START/ +30sec. button is pressed.
- When cooking/defrosting is complete, the time of day will reappear on the display, if the clock has been set.
- If you wish to know the power level during cooking, press the POWER LEVEL button. The current power level will be displayed for 3 seconds.

KITCHEN TIMER MODE

You can use the kitchen timer, in instances where microwave cooking is not involved for example to time boiled eggs cooked on conventional cooktop or to monitor the standing time for cooked/ defrosted food.

Example:

To set the timer for 5 minutes.

1. Press TIMER/CLOCK once.

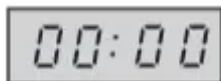

2. Rotate ENTRY dial to select time .



3. Press the START/+30sec key to start the timer.

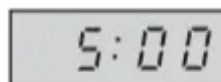

4. Check the display. (The display will count down through the programmed time.)

When the timer arrives at 0:00, an audible signal will sound 5 times and the LED will then display the time of day.

You can enter any time up to 95 minutes. To cancel the KITCHEN TIMER while counting down, simply press the STOP/CLEAR button.

NOTE: The KITCHEN TIMER function cannot be used while cooking.

OTHER CONVENIENT FUNCTION

1. MULTI-STAGE COOKING

This function allows you to cook using up to 2 different stages which can include manual cooking times or time defrost as well as a auto defrost function. Once programmed there is no need to interfere with the cooking operation as the oven will automatically move onto the next stage. An audible signal will sound once after the first stage. If the defrost function is needed within sequence cooking, please note that this should always be the first stage of sequence cooking.

NOTE: AUTO MENU cannot be set as one of the multi-stage sequences.

Example: If you want to cook food for 20 minutes on 100% microwave power and then for 5 minutes with 80% microwave power. The steps are as follows:

1. Press the POWER LEVEL button, P100 will appear in the LED display.

2. Press the START/+30sec button once to confirm the setting.
3. Enter the cooking time by rotating the ENTRY dial until the display shows "20:00" minutes.
4. Press the POWER LEVEL button, P100 will appear in the LED display.
5. Press the POWER LEVEL button twice or rotate the ENTRY dial to select the microwave power to P80.
6. Press the START/+30sec. button once more to confirm the setting.
7. Enter the cooking time by rotating the ENTRY dial until the display shows "5:00" minutes.
8. Press the START/ +30sec. button to start cooking.

2. CHILD LOCK:

Use to prevent unsupervised operation of the oven by children.

- a. To set the CHILD LOCK:

Press and hold the STOP/CLEAR button for 3 seconds until the display shows: or current time.

- b. To cancel the CHILD LOCK:

Press and hold the STOP/CLEAR button for 3 seconds until a long beep sounds.



SENSOR MENU FUNCTION

Example: To cook pizza with a weight of 8 Oz by using the SENSOR MENU function.

1. Press the SENSOR MENU button to select the desired sensor menu.

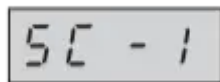

2. Press the SENSOR MENU button once, then rotate the ENTRY dial to select the desired auto menu.

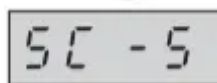

3. Press the START/ +30sec./ button to start cooking. (The display will count down through the programmed cooking time.)

Menu	Weight	Initial Temp.	Additional Instructions
SC-1 Sensor Reheat	8~12 Oz	5 degrees	Reheat food is dinner plate. When sensor time finish, Cooking time counts down.Now you can mix it and then continue reheating.
SC-2 Potato	1~4 Units (6~8Oz each one)	Room Temp.	Pierce each potato with a fork 6 times around it's surface. Place potatoes around the edge of a paper-towel-lined turntable. Do not cover. If additional time is needed, continue to cook manually. Please let stand for 5 minutes in the oven after finishing to avoid burning.
SC-3 Fresh Vegetable	4~16Oz (110~450g)	Room Temp.	All pieces should be the same size. Wash thoroughly, add 15ml water per 125g vegetables, and cover with a lid or vented plastic wrap. When cooking time counts down. Press " STOP/CLEAR " to pause and open the oven door to mix and then continue to cook.
SC-4 Frozen entree	8~32 Oz (225~900g)	minus 18 degrees	Be careful when removing the film cover after cooking. Remove Facing away from you to avoid steam burns. If additional time is needed, continue to cook manually. Cover the film before cooking and leave a spacing near the edge of the container in order to let the steam out. When buzzer sound twice, cooking time counts down. Press " STOP/CLEAR " to pause and open the oven door to mix.
SC-5 Frozen Pizza	6~12 Oz (170~340g)	minus 18 degrees	If the weight is over 12 OZ,please set the additional cooking time manually.
SC-6 Frozen Vegetable	6~16Oz (170~450g)	minus 18 degrees	Wash thoroughly, add 15ml water per 125g vegetables, and cover with a lid or vented plastic wrap.

			Do not salt/butter vegetables until after cooking.
--	--	--	--

NOTE:

1. Food to be avoided in sensor reheating.
 - a. Bread and other dry food, such as biscuit, cake.
 - b. For raw or uncooked foods.
 - c. Beverage and frozen food.
2. The oven cannot cook automatically when the temperature of the oven cavity is high.
3. The reheat food can be covered with the lid. But the lid must have a vent hole in order to emanate the steam. Sealed utensil is forbidden.
4. During sensor cooking process, please do not open the oven door or press "STOP/CLEAR" key. Otherwise, the sensor will make mistakes.
5. The sensor reheat has different request for different food.

Casseroles - Add 3 to 4 tablespoons of water, cover with lid or vented plastic wrap.

Stir when time appears in the display window.

Canned foods - Empty contents into casserole dish or serving bowl, cover dish with lid or vented plastic wrap. After reheating, let stand for a few minutes.

Plate of food - Arrange food on plate; top with butter, gravy, etc. Cover with lid or vented plastic wrap. After reheating, let stand for a few minutes.

Care of Your Microwave Oven

The oven should be cleaned regularly and any food deposits removed.

Failure to maintain the oven in a clean condition could lead to deterioration of the surface that could adversely affect the life of the appliance and possibly result in a hazardous situation.

1. Turn the oven off before cleaning.
2. Keep the inside of the oven clean. When food spatters or spilled liquids adhere to oven walls, wipe with a damp cloth. Mild detergent may be used if the oven gets very dirty. The use of harsh detergent or abrasives is not recommended.
3. The outside oven surface should be cleaned with soap and water, rinsed and dried with a soft cloth. To prevent damage to the operating parts inside the oven, water should not be allowed to seep into the ventilation openings.
4. If the Control Panel becomes wet, clean with a soft, dry cloth. Do not use harsh detergents or abrasives on Control Panel.

5. If steam accumulates inside or around the outside of the oven door, wipe with a soft cloth. This may occur when the microwave oven is operated under high humidity conditions and in no way indicates malfunction of the unit.
6. It is occasionally necessary to remove the glass tray for cleaning. Wash the tray in warm sudsy water or in a dishwasher.
7. The roller guide and oven cavity floor should be cleaned regularly to avoid excessive noise. Simply wipe the bottom surface of the oven with mild detergent water or window cleaner and dry. The roller guide may be washed in mild sudsy water.

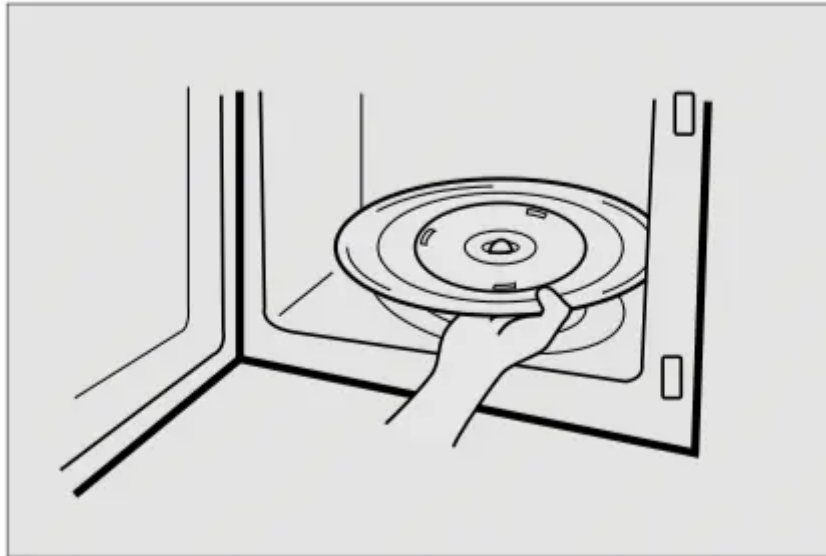

ROLLER GUIDE

1. The ROLLER GUIDE and oven floor should be cleaned frequently to prevent excessive noise.
2. The ROLLER GUIDE **MUST ALWAYS** be used for cooking together with the Glass Tray.

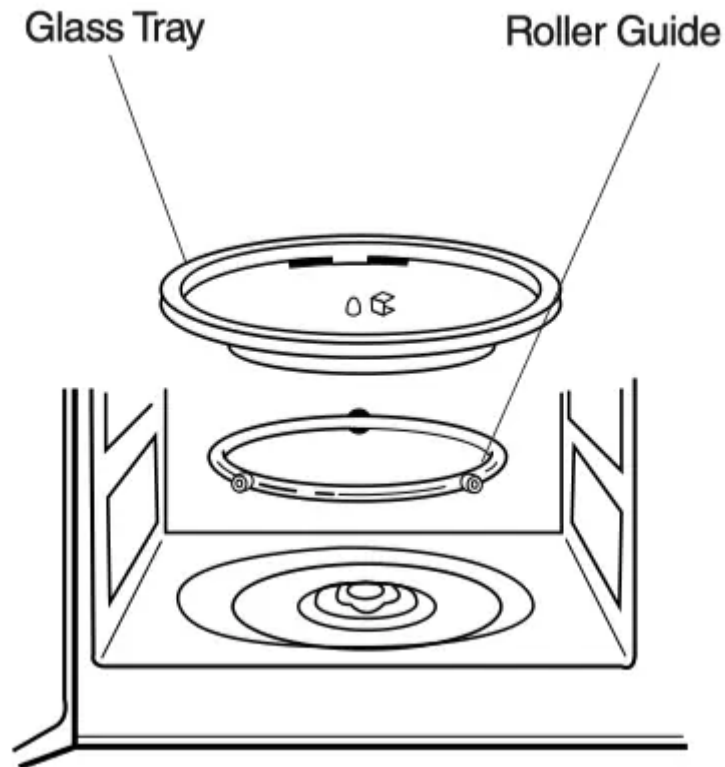

GLASS TRAY

1. DO NOT operate the oven without the Glass Tray in place.
2. DO NOT use any other Glass Tray with this oven.
3. If Glass Tray is hot, ALLOW TO COOL before cleaning or placing it in water.
4. DO NOT cook directly on the Glass Tray. (Except for popcorn)

BEFORE YOU CALL FOR SERVICE

Refer to following checklist, you may prevent an unnecessary service call.

*** The oven doesn't work :**

1. Check that the power cord is securely plugged in.
2. Check that the door is firmly closed.
3. Check that the cooking time is set.
4. Check for a blown circuit fuse or tripped main circuit breaker in your house.

*** Sparking in the cavity:**

1. Check utensils. Metal containers or dishes with metal trim should not be used.
2. Check that metal skewers or foil does not touch the interior walls.
3. Ensure the microwave is clean and free of all food particles/splatter or grease.

CARE AND CLEANING

Although your oven is provided with safety features, it is important to observe the following:

1. It is important not to defeat or tamper with safety interlocks.
2. Do not place any object between the oven front face and the door or allow residue to accumulate on sealing surfaces. Wipe the sealing area frequently with a mild detergent, rinse and dry. Never use abrasive powders or keys.
3. When opened, the door must not be subjected to strain, for example, a child hanging on an opened door or any load could cause the oven to fall forward to cause injury and also damage to the door. Do not operate the oven if it is damaged, until it has been repaired by a competent service technician. It is particularly important that the oven closes properly and that there is no damage to the:
 - i) Door(bent)
 - ii) Hinges and Hookes(broken or loosened)
 - iii) Door seals and sealing surfaces.
4. The oven should not be adjusted or repaired by anyone except a properly competent service technician.
5. The oven should be cleaned regularly and any food deposits removed;
6. Failure to maintain the oven in a clean condition could lead to deterioration of the surface that could adversely affect the life of the appliance and possibly result in a hazardous situation.

Questions and Answers

*** Q : I accidentally ran my microwave oven without any food in it. Is it damaged?**

* A : Running the oven empty for a short time will not damage the oven. However, it is not recommended.

*** Q : Can the oven be used with the glass tray or roller guide removed?**

* A : No. Both the glass tray and roller guide must always be used in the oven before cooking.

*** Q : Can I open the door when the oven is operating?**

* A : The door can be opened anytime during the cooking operation. Then microwave energy will be instantly switched off and the time setting will maintain until the door is closed.

*** Q : Why do I have moisture in my microwave oven after cooking?**

* A : The moisture on the side of your microwave oven is normal. It is caused by steam from cooking food hitting the cool oven surface.

*** Q : Does microwave energy pass through the viewing screen in the door?**

* A : No. The metal screen bounces back the energy to the oven cavity. The holes are made to allow light to pass through. They do not let microwave energy pass through.

*** Q : Why do eggs sometimes pop?**

* A : When baking or poaching eggs, the yolk may pop due to steam build-up inside the yolk membrane. To prevent this, simply pierce the yolk with a toothpick before cooking. Never cook eggs without piercing their shells.

*** Q : Why is this standing time recommended after the cooking operation has been completed?**

* A : Standing time is very important.

With microwave cooking, the heat is in the food, not in the oven. Many foods build up enough internal heat to allow the cooking process to continue, even after the food is removed from the oven. Standing time for joints of meat, large vegetables and cakes is to allow the inside to cook completely, without overcooking the outside.

*** Q : What does “standing time” mean?**

* A : “Standing time” means that food should be removed from the oven and covered for additional time to allow it to finish cooking. This frees the oven for other cooking.

*** Q : Why does my oven not always cook as fast as the microwave cooking guide says?**

* A : Check your cooking guide again, to make sure you've followed directions exactly ; and to see what might cause variations in cooking time. Cooking guide times and heat settings are suggestions, to help prevent over-cooking... the most common problem in getting used to a microwave oven. Variations in the size, shape and weights and dimensions could require longer cooking time. Use your own judgement along with the cooking guide suggestions to check whether the food has been properly cooked just as you would do with a conventional cooker.

*** Q : Will the microwave oven be damaged if it operates while empty?**

* A : Yes. Never run it empty.

*** Q : Can I operate my microwave oven without the turntable or turn the turntable over to hold a large dish?**

* A : No. If you remove or turn over the turntable, you will get poor cooking results. Dishes used in your oven must fit on the turntable.

*** Q : Is it normal for the turntable to turn in either direction?**

* A : Yes. The turntable rotates clockwise or counterclockwise, depending on the rotation of the motor when the cooking cycle begins.

*** Q : Can I pop popcorn in my microwave oven? How do I get the best results?**















* A : Yes. Pop packaged microwave popcorn following manufacture’s guidelines. Do not use regular paper bags. Use the “listening test” by stopping the oven as soon as the popping slows to a “pop” every 1 or 2 seconds. Do not repop unpopped kernels. Do not pop popcorn in glass cookware.



Cooking Instructions

UTENSIL GUIDE

Only use utensils that are suitable for use in microwave ovens.

To cook food in the microwave oven, the microwaves must be able to penetrate the food, without being reflected or absorbed by the dish used. Care must therefore be taken choosing the utensil. If the utensil is marked microwave-safe, you do not need to worry. The following table lists various utensil and indicates whether and how they should be used in a microwave oven.

UTENSIL	SAFE	COMMENTS
Aluminium foil		Can be used in small quantities to protect areas against overcooking. Arcing can occur if the foil is too close to the oven wall or if too much foil is used.
Crust plate		Do not preheat for more than 8minutes.
China and earthenware		Porcelain, pottery, glazed earthenware and bone china are usually suitable, unless deco-rated with a metal trim.
Disposable polyester cardboard dishes		Some frozen foods are packaged in these dishes.
Fast-food packaging <ul style="list-style-type: none"> • Polystyrene cups containers • Paper bags or newspaper • Recycled paper or metal trims 	  	<p>Can be used to warm food. Overheating may cause the polystyrene to melt.</p> <p>May catch fire.</p> <p>May cause arcing.</p>
Glassware <ul style="list-style-type: none"> • Oven-to-table ware • Fine glassware • Glass jars 	  	<p>Can be used, unless decorated with a metal trim. Can be used to warm foods or liquids.</p> <p>Delicate glass may break or crack if heated suddenly. Must remove the lid. Suitable for warming only.</p>
Metal <ul style="list-style-type: none"> • Dishes • Freezer bag twist ties 	 	May cause arcing or fire.
Paper <ul style="list-style-type: none"> • Plates, cups, napkins and Kitch- en paper 	 	<p>For short cooking times and warming. Also to absorb excess moisture.</p> <p>May cause arcing.</p>

• Recycled paper		
Plastic • Containers • Cling film • Freezer bags		Particularly if heat-resistant thermoplastic. Some other plastics may warp or discolour at high temperatures. Do not use Melamine plastic. Can be used to retain moisture. Should not touch the food. Take care when removing the film as hot steam will escape. Only if boilable or oven-proof. Should not be airtight. Prick with a fork, if necessary.
Wax or grease-proof paper		Can be used to retain moisture and prevent spattering.

- : Recommended use
- ▲ : Limited Use
- × : Not Recommended

USE YOUR MICROWAVE OVEN SAFELY

General use

Do not attempt to defeat or tamper with safety interlocks.

Do not place any object between the oven front frame and the door or allow residue to build up on sealing surfaces. Wipe with a mild detergent, rinse and dry. Never use abrasive powders or keys.

Do not subject the oven door to strain or weight such as a child hanging on an open door.

This could cause the oven to fall forward resulting in injury to you and damage to the oven.

Do not operate the oven if door seals or sealing surfaces are damaged; or if door is bent; or if hinges are loose or broken.

Do not operate the oven empty. This will damage the oven.

Do not attempt to dry clothes, newspapers or other materials in the oven. They may catch on fire.

Do not use recycled paper products as they may contain impurities which may cause sparks or fires.

Do not hit or strike the control panel with hard objects. This can damage the oven.

Food

Never use your microwave oven for home canning. The oven is not designed for proper home canning. Improperly canned food may spoil and be dangerous to consume.

Always use the minimum recipe cooking time. It is better to undercook rather than overcook foods. Undercooked foods can be returned to the oven for more cooking. If food is overcooked, nothing can be done.

Heat small quantities of food or foods with low moisture carefully. These can quickly dry out, burn or catch on fire.

Do not heat eggs in the shell. Pressure may build up and eggs can explode.

Potatoes, apples, egg yolks and sausages are examples of food with non-porous skins.

These must be pierced before cooking to prevent bursting.

Do not attempt to deep fat fry in your microwave oven. Always allow a standing time of at least 20 seconds after the oven has been switched off to allow the temperature to even out, stir during heating, if necessary, and ALWAYS stir after heating. To prevent eruptive boiling and possible scalding, you should put a spoon or glass stick into the beverages and stir before, during and after heating.

Do not leave the oven unattended while popping corn. Do not pop corn in a paper bag unless it is the commercially prepared Microwave Popcorn product. The kernels can overheat and ignite a brown paper bag.

Do not put packaged Microwave Popcorn bags directly on the oven tray. Place the package on a microwave safe glass or ceramic plate to avoid overheating and cracking the oven tray.

Do not exceed the Microwave Popcorn manufacturers suggested popping time.

Longer popping does not yield more popcorn but it can result in scorch, burn or fire. Remember, the Popcorn bag and tray can be too hot to handle. Remove with caution and use pot holders.

ARCING

If you see arcing, open the door and correct the problem.

Arcing is the microwave term for sparks in the oven. Arcing is caused by:

- Metal or foil touching the side of the oven.
- Foil not molded to food (upturned edges act like antennas).
- Metal, such as twist-ties, poultry pins, or gold rimmed dishes, in the microwave.
- Recycled paper towels containing small metal pieces being used in the microwave.

MICROWAVING PRINCIPLES

Microwave energy has been used in this country to cook and reheat food since early experiments with RADAR in World War II. Microwaves are present in the atmosphere all the time, both naturally and manmade sources. Manmade sources include radar, radio, television, telecommunication links and car phones.

HOW MICROWAVES COOK FOOD

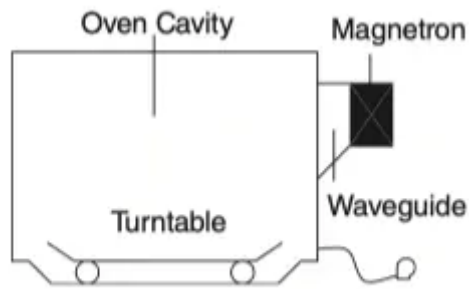

In a microwave oven, electricity is converted into microwave by the MAGNETRON.

TRANSMISSION



Then they pass through the cooking containers to be absorbed by the water molecules in the food, all foods contain water to a more or lesser extent.

REFLECTION



The microwaves bounce off the metal walls and the metal door screen.

ABSORPTION

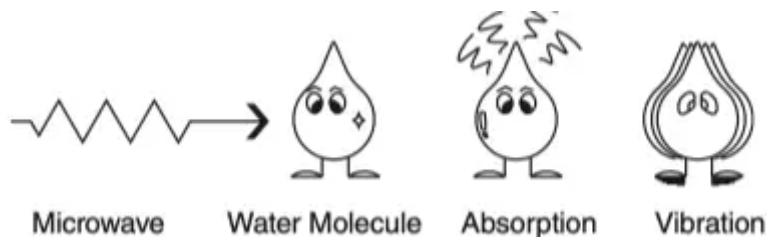

The microwaves cause the water molecules to vibrate which causes FRICTION, i.e. HEAT. This heat then cooks the food. Microwaves are also attracted to fat and sugar particles, and foods high in these will cook more quickly. Microwaves can only penetrate to a depth of 1½ - 2 inches(4-5cm)

and as heat spreads through the food by conduction, just as in a traditional oven, the food cooks from the outside inwards.

CONVERSION CHARTS

WEIGHT MEASURES		VOLUME MEASURES		SPOON MEASURES	
15 g	1/2 oz.	30 ml	1 fl.oz.	1.25 ml	1/4 tsp
25 g	1 oz.	100 ml	3 fl.oz.	2.5 ml	1/2 tsp
50 g	2 oz.	150 ml	5 fl.oz. (1/4 pt)	5 ml	1 tsp
100 g	4 oz.	300 ml	10 fl.oz. (1/2 pt)	15 ml	1 tbsp
175 g	6 oz.	600 ml	20 fl.oz. (1pt)		
225 g	8 oz.				
450 g	1 lb.				

FLUID MEASUREMENTS		
1 Cup	= 8 fl.oz	= 240 ml
1 Pint	= 16 fl.oz. (UK 20 fl.oz.)	= 480 ml (UK 560 ml)
1 Quart	= 32 fl.oz. (UK 40 fl.oz.)	= 960 ml (UK 1120 ml)
1 Gallon	= 128 fl.oz. (UK 160 fl.oz.)	= 3840 ml (UK 4500 ml)

COOKING TECHNIQUES

STANDING TIME

Dense foods e.g. meat, baked potatoes and cakes, require standing time (inside or outside of the oven) after cooking, to allow heat to finish conducting to cook the center completely. Wrap roasts and baked potatoes in aluminium foil while standing. Roasts need approx. 10-15 minutes, baked potatoes 5 minutes. Other foods such as plated meal, vegetables, fish etc require 2-5 minutes standing. After defrosting food, standing time should also be allowed. If food is not cooked after standing time, return to the oven and cook for additional time.

MOISTURE CONTENT

Many fresh foods e.g. vegetables and fruit, vary in their moisture content throughout the season, particularly baked potatoes. For this reason cooking times may have to be adjusted. Dry ingredients e.g. rice, pasta, can dry out during storage so cooking times may differ.

DESTINY

Porous airy foods heat more quickly than dense heavy foods.

CLING FILM

Cling film helps keep the food moist and the trapped steam assists in speeding up cooking times. Pierce before cooking to allow excess steam to escape. Always take care when removing cling film from a dish as the build-up of steam will be very hot.

SHAPE

Even shapes cook evenly. Food cooks better by microwave when in a round container rather than square.

SPACING

Foods cook more quickly and evenly if spaced apart. NEVER pile foods on top of each other.

STARTING TEMPERATURE

The colder the food, the longer it takes to heat up. Food from a fridge takes longer to reheat than food at room temperature.

LIQUIDS

All liquids must be stirred before and during heating. Water especially must be stirred before and during heating, to avoid eruption. Do not heat liquids that have previously been boiled. DO NOT OVERHEAT.

TURNING & STIRRING

Some foods require stirring during cooking. Meat and poultry should be turned after half the cooking time. ARRANGING Individual foods e.g. chicken portions or chops, should be placed on a dish so that the thicker parts are towards the outside.

QUANTITY

Small quantities cook faster than large quantities, also small meals will reheat more quickly than large portions.

PIERCING

The skin or membrane on some foods will cause steam to build up during cooking. These foods must be pierced or a strip of skin should be peeled off before cooking to allow the steam to escape. Eggs, potatoes, apples, sausages etc, will all need to be pierced before cooking. DO NOT ATTEMPT TO BOIL EGGS IN THEIR SHELLS.

COVERING

Cover foods with microwave cling film or a lid. Cover fish, vegetables, casseroles, soups. Do not cover cakes, sauces, baked potatoes or pastry items.

DEFROSTING GUIDE

- ▶ Do not defrost covered meat. Covering might allow cooking to take place. Always remove outer wrap and tray. Use only containers that are microwave-safe.
- ▶ Begin defrosting whole poultry breast-side-down. Begin defrosting roasts fat-side-down.
- ▶ The shape of the package alters the defrosting time. Shallow rectangular shapes defrost more quickly than a deep block.
- ▶ After 1 /3 of the defrost time has elapsed, check the food. Toy may wish to turn over, break apart, rearrange or remove thawed portions of the food.

- ▶ During defrost, the oven will prompt you to turn the over. At this point, open oven door and check the food. Follow the techniques listed below for optimum defrost results. Then, close oven door, touch the START key to complete defrosting.
- ▶ When defrosted, food should be cool, but softened in all areas. If still slightly icy, return to microwave oven very briefly, or let stand a few minutes. After defrosting, allow food to stand 5-60 minutes if there are any icy areas. Poultry and fish may be placed under running cool water until defrosted
 - Turn over : Roast, ribs, whole poultry, turkey breasts, hot dogs, sausages, steaks, or chops.
 - Rearrange : Break apart or separate steaks, chops, hamburger patties, ground meat, chicken or seafood pieces, chunks of meat such as stew beef.
 - Shield : Use small strips of aluminum foil to protect thin areas or edges of unevenly shaped foods such as chicken wings. To prevent arcing, do not allow foil to come within 1-inch of oven walls or door.
 - Remove : To prevent cooking, thawed portions should be removed from the oven at this point. This may shorten defrost time for food weighing less than 3 lbs.(1350g).

Cooking chart

ITEM	POWER LEVEL	COOKING TIME PER LB./450G	SPECIAL INSTRUCTION
MEAT	P-80	6-8 min.	- Chilled meat and poultry should be removed from the refrigerator at least 30 minutes before cooking. - Always let the meat and poultry stand, covered after cooking.
Beef roast - Rare	P-80	7-9 min.	
- Medium	P-80	9-11 min.	
- well done	P-HI	10-13 min.	
Pork roast	P-HI	8-10 min.	
Bacon roast			
POuLTRY	P-HI	4-9 min.	
Whole chicken	P-80	5-7 min.	
Portions chicken	P-80	6-8 min.	
Breast (boned)			
FISH	P-HI	3-5 min.	- Brush a little oil or melted butter over the fish, or add 15~30ml(1-2 tbsp) lemon juice, wine, stock, milk or water. - Always let the fish stand, covered, after cooking
Fish Fillets	P-HI	3-5 min.	
Whole Mackerel, Cleaned and prepared	P-HI	4-6 min.	
Whole Trout, Cleaned & Prepared	P-HI	4-6 min.	
Salmon steaks			

NOTE : The above times should be regarded only as a guide. Allow for difference in individual tastes and preferences.

The times may vary due to the shape, cut, and composition of the food. Frozen meat, poultry and fish must be thoroughly thawed before cooking.

COOKING & REHEATING CHART

Reheating chart

- Baby food particularly needs to be checked carefully before serving to prevent burns.

- When heating pre-packaged ready-cooked foods, always follow the pack instructions carefully.
- If you freeze foods which were bought from the fresh or chilled counters, remember that they should be thoroughly thawed before following the heating instructions on the packed. It's worth putting a note on them so that other members of the household will remember too.
- Remember metal ties and transfer food from foil containers before reheating.
- Chilled(refrigerated) food takes longer to reheat than food at room temperature (such as just-cooled food or food from the store cupboard).
- All foods should be reheated using full microwave power.

ITEM	COOKING TIME	SPECIAL INSTRUCTIONS
Baby food 128g / 5.12 oz jar	20 sec.	Empty into a small serving bowl. Stir well once or twice during heating. Before serving, check the temperature carefully.
Baby milk 100ml / 4fl.oz. 225ml / 8fl.oz.	20-30 sec. 40-50 sec.	Stir or shake well and pour into a sterilized bottle. Before serving, shake well and check the temperature carefully.
Sandwich roll or bun 1 roll	20-30 sec.	Wrap in paper towel and place on glass microwaveable rack. *Note : Do not use recycled paper towels.
Lasagna 1 serving (10 ½ oz./ 300g)	4-6 min.	Place lasagna on microwaveable plate. Cover with plastic wrap and vent.
Casserole 1 cup 4 cups	1 ½-3 min. 5-7 min.	Cook covered, in microwaveable casserole. Stir once halfway through cooking.
Mashed potatoes 1 cup 4 cups	2-3 min. 6-8 min.	Cook covered, in microwaveable casserole. Stir once halfway through cooking.
Baked beans 1 cup	2-3 min.	Cook covered, in microwaveable casserole. Stir once halfway through cooking.
Ravioli or pasta in sauce 1 cup 4 cups	2-3 min. 6-9 min.	Cook covered, in microwaveable casserole. Stir once halfway through cooking.

VEGETABLE CHART

Use a suitable glass bowl with lid. Add 30-45ml cold water(2-3 tbsp.) for every half pound unless another water quantity is recommended - see table. Cook covered for the minimum time - see table.

Continue cooking to get the result you prefer. Stir once during and once after cooking. Add salt, herbs or butter after cooking. Cover during a standing time of 3 minutes.

Hint : cut the fresh vegetables into even sized pieces. The smaller they are cut, the quicker they will cook.

All vegetables should be cooked using full microwave power.

Cooking guide for fresh vegetables

VEGETABLES	WEIGHT	TIME	COMMENTS
Broccoli	½ lb./250g 1 lb./500g	2-3 min 4-6 min	Prepare even sized florets. Arrange the stems to the centre.
Brussels sprouts	½ lb./250g	3-4 min	Add 60-75ml(4-5 tbsp.) water.
Carrots	½ lb./250g	2-3 min	Cut carrots into even sized slices.
Cauliflower	½ lb./250g 1 lb./500g	2-3 min 4-6 min	Prepare even sized florets. Cut big florets into halves. Arrange stems to the centre.
Zucchini	½ lb./250g	2-3 min	Cut zucchini into slices. Add 30ml(2tbsp.) water or a knob of butter. Cook until just tender.
Aubergine (eggplant)	½ lb./250g	2-3 min	Cut eggplant into small slices and sprinkle with 1 table- spoon lemon juice.
Leeks	½ lb./250g	2-3 min	Cut leeks into thick slices.
Mushrooms	0.3 lb./125g ½ lb./250g	1-2 min 2-4 min	Prepare small whole or sliced mushrooms. Do not add any water. Sprinkle with lemon juice. Spice with salt and pepper. Drain before serving.
Onions	½ lb./250g	2-3 min	Cut onions into slices or halves. Add only 15ml(1tbsp.) water.
Pepper	½ lb./250g	2-4 min	Cut pepper into small slices.
Potatoes	½ lb./250g 1 lb./500g	3-5 min 5-7 min	Weigh the peeled potatoes and cut them into similar sized halves or quarters.

Cooking guide for frozen vegetables

Vegetables	WEIGHT	TIME	INSTRUCTIONS
spinach	0.3 lb./ 125g	1-2 min	Add 15ml(1tbsp.) cold water.
broccoli	½ lb./250g	2½-4 min	Add 30ml(2 tbsp.) cold water.
Peas	½ lb./250g	2½-4 min	Add 15ml(1 tbsp.) cold water.
Green beans	½ lb./250g	3-5 min	Add 30ml(2 tbsp.) cold water.
Mixed vegetables (carrots/peas/ corn)	½ lb./250g	2½-4 min	Add 15ml(1 tbsp.) cold water.
Mixed vegetables (Chinese style)	½ lb./250g	3-5 min	Add 15ml(1 tbsp.) cold water.

Warning

This content is compiled from multiple sources and is provided for reference purposes only. It may not be complete or fully applicable to all situations. If you are unable to resolve your issue, please contact the product manufacturer or an authorized service provider for official support.