

## USING THE RANGE

### Surface Units

#### How to Set

Push the knob in and turn in either direction to the setting you want.

A surface ON indicator light will glow when any surface unit is on

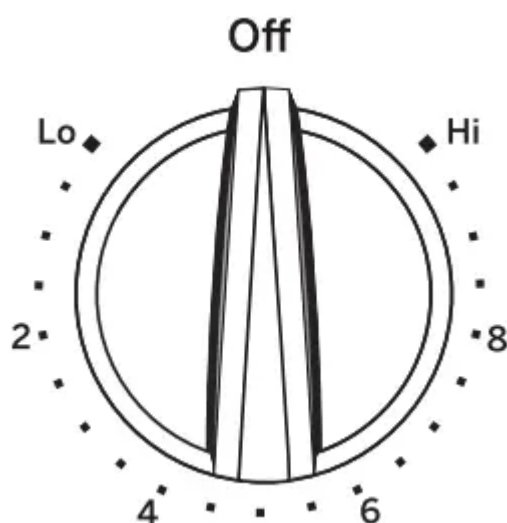

At both OFF and HI the control clicks into position. You may hear slight clicking sounds during cooking, indicating the control is maintaining your desired setting. Be sure you turn the control knob to OFF when you finish cooking.

### Home Canning Tips

Be sure the canner is centered over the surface unit. Make sure the canner is flat on the bottom.

To prevent burns from steam or heat, use caution when canning.

Use recipes and procedures from reputable sources. These are available from manufacturers such as Ball® and Kerr® and the Department of Agriculture Extension Service.

Flat-bottomed canners are recommended. Use of water bath canners with rippled bottoms may extend the time required to bring the water to a boil.

## Oven Controls

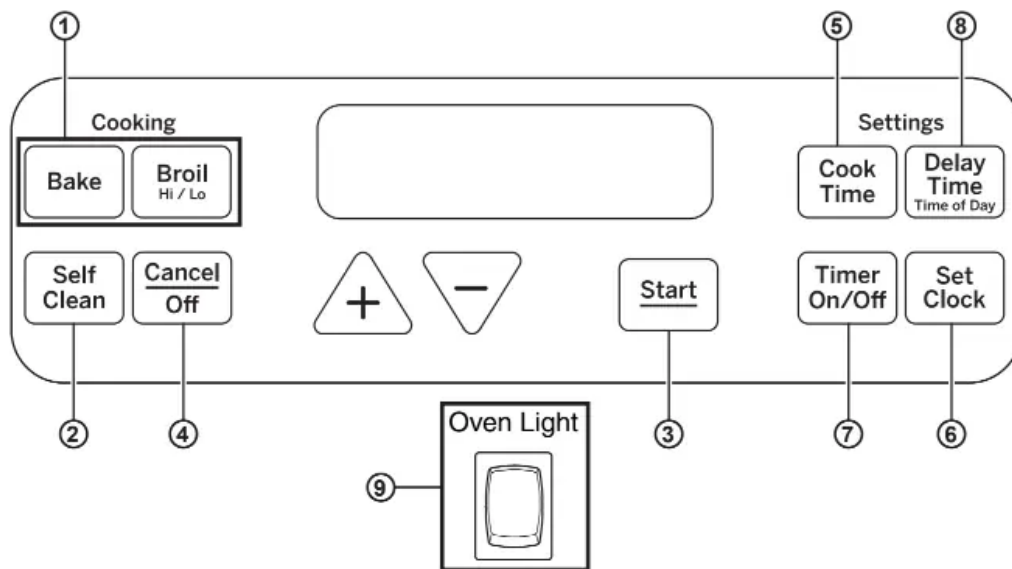

**1. Traditional Cooking Modes:** Your oven has the following traditional cooking modes: Bake and Broil Hi/Lo. See the Cooking Modes section for more information.

**2. Self Clean:** See the Cleaning the Oven section for important information about using this mode.

**3. Start:** Must be pressed to start any cooking, cleaning, or timed function.

**4. Cancel/Off:** Cancels ALL oven operations except the clock and timer.

**5. Cook Time:** Counts down cooking time and turns off the oven when the cooking time is complete. Press the **Cook Time** pad, use the +/- pads to program a cooking time in hours and minutes, then press **Start**. This can only be used with Bake.

**6. Set Clock:** Sets the oven clock time. Press the **Set Clock** pad and the +/- pads to program the clock. Press **Start** to save the time.

**7. Timer:** Works as a countdown timer. Press the **Timer** pad and the +/- pads to program the time in hours and minutes. Press the **Start** pad. The timer countdown is complete. To turn the timer off press the **Timer** pad.

**8. Delay Time:** Delays when the oven will turn on. Use this to set a time when you want the oven to start. Press the **Delay Time** pad and use the +/- pads to program the time of day for the oven to turn on then press **Start**. Press the desired cooking mode and temperature then press **Start**. A cook time may also be programmed if desired. Follow the directions under Cook Time for setting this feature. This can only be used with Bake and Self-Clean. **NOTE:** When using the delay time feature, foods that spoil easily—such as milk, eggs, fish, stuffings, poultry and pork—should not be allowed to sit for more than 1 hour before or after cooking. Room temperature promotes the growth of harmful bacteria. Be sure that the oven light is off because heat from the bulb will speed harmful bacteria growth.

**9. Oven Light:** Turns the oven light on or off.

## Special Features

There are several different special features on your range. To change the settings of these special features:

- Press the **Bake** and **Broil** pads at the same time and hold for three seconds.
- “SF” will appear in the display.
- Select the feature you want to change.
- When the change has been made, press the **Start** key to save the change and return to the time of day.

## Adjust the Oven Temperature

This feature allows the oven baking temperature to be adjusted up to 35°F hotter or down to 35°F cooler. Use this feature if you believe your oven temperature is too hot or too cold and wish to change it. This adjustment

affects Bake mode. No other cooking modes are affected.

Press the **Bake** pad again to enter the temperature adjustment mode. A number between 35 and -35 will display. Use the number pads to set the desired temperature adjustment and use the **Bake** pad to change between negative and positive.

Press the **Start** pad to save the temperature adjustment.

## End of Timer Signals

This is the tone that signals the end of a timer. The tone can be continuous (Con bEEP) or one repeating beep (bEEP). A continuous setting will continue to sound a tone until a button on the control is pressed. Press the **Timer** pad to view the current setting and then to change the setting.

## Fahrenheit or Celsius Temperature Display

The oven control is set to use Fahrenheit temperatures (F), but you can change it to use Celsius temperatures (C). Press the **Cooking Time & Broil** pads at the same time to view the current setting, press again to change the setting.

## Clock Display

This feature specifies how the time of day will be displayed or if no time of day will be displayed. You can select a standard 12-hour clock (12 H), 24-hour military time display (24 H), or no clock displayed (oFF). Press the **Set Clock** pad to view the current setting, press again to change the setting.

## 12-hour auto shut-off and Sabbath

Options for this feature are “12 SHdn”, “no SHdn” and “SAbbAtH”.

12-hour auto shut-off turns off the oven after 12 hours of continuous operations.

Sabbath mode disables all sounds (the control will not beep when a button is pressed), Broil, Cook Time, Timer, Clock, and Delay Time functions. Sabbath mode can only be used with Bake. This feature conforms to the Star-K Jewish Sabbath requirements.

Press the **Delay Time** pad to view the current setting and then to change the setting.

To use Sabbath mode, select “SAbbAtH” and press **Start**. A ] will appear in the display and the clock will not display.

Once in Sabbath mode, at any time you can press **Bake**, use the number pads to enter a temperature between 170°F and 550°F, and press **Start**. No sound will be given when the keys are pressed. At a random time between 30 seconds and 1 minute, ][, will appear in the display indicating the oven is running.

If you need to adjust the temperature, press **Bake**, use the number pads to enter a new temperature between 170°F and 550°F, and press **Start**.

To turn the oven off, press **Cancel/Off** at any time. **The oven will immediately turn off** and ][ will change to ] indicating that the oven has turned off.

To exit Sabbath mode, make sure that the oven is turned off. Press and hold the **Bake** and **Broil** pads for 3

seconds to enter special features then press Delay Time until either “**12 Shdn**” or “**no Shdn**” is in the display and press **Start**.

**NOTE:** If power outage occurs during Sabbath mode the unit will remain in Sabbath mode but off when power is restored.

If you wish to use the Cook Time feature (if available) to bake in the oven and then have the oven automatically turn off, you will need to press the **Cook Time** pad, enter a cooking time duration, and press **Start**. Then enter special features to start Sabbath mode as detailed above.

## Cook and Hold

Your new control has a cook and hold feature that keeps cooked foods warm for up to 3 hours after the cooking function is finished.

This feature can be used only at the end of a timed baking cycle which has an automatic stop.

To activate this feature, follow the steps below:

1. Press the **Bake** and **Broil HI/LO** pads at the same time for 3 seconds until the display shows “**SF**”.

2. Press the **Cook Time** pad. The display will show "**Hld OFF**". Press the **Cook Time** pad again to activate the feature. The display will show "**Hld ON**".
3. Press the **Start** pad to activate the cook and hold feature and leave the control set in this special features mode.

### Changing the Speed of the Increase or Decrease Pads

As you use the **Increase** or **Decrease** pads when setting a time or temperature, you may notice the display changes slowly. This special feature allows you to change the speed.

To set the speed you prefer, follow the steps below:

1. Press the **Bake** and **Broil HI/LO** pads at the same time for 3 seconds until the display shows "**SF**".
2. Press the **Increase** pad. The display will show you a set speed between 1 and 5.
3. Press the **Increase** pad to increase the speed up to the number 5. Press the **Decrease** pad to decrease the speed down to the number 1.
4. Press **Start** to activate the setting and leave the control set in this special features mode.

### Oven Racks

Your oven has seven rack positions. Recommended rack positions for various types of foods are provided in the Cooking Guide. Adjusting rack position is one way to impact cooking results. For example, if you would prefer darker tops on cakes, muffins, or cookies, try moving food one rack position higher. If you find foods are too brown on top try moving them down next time.

When baking with multiple pans and on multiple racks, ensure there is at least 1" between pans to allow sufficient space for air to flow.

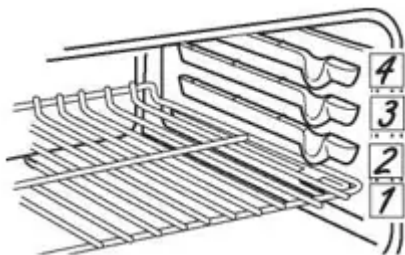

### Flat Racks

When placing and removing cookware, pull the rack out to the bump (stop position) on the rack support.

To remove a rack, pull it toward you, tilt the front end up and pull it out.

To replace, place the curved end of the rack (stop-locks) onto the oven supports, tilt up the front of the rack and push the rack in.

Racks may become difficult to slide, especially after a self-clean. Put some vegetable oil on a soft cloth or paper towel and rub onto the left and right edges.

**NOTE:** Using other cooking oils will cause a discoloring or a rust like color residue on the racks and cavity sides. To clean this residue, use a soap and water or a vinegar and water solution. Rinse with clean water and dry with a soft cloth.

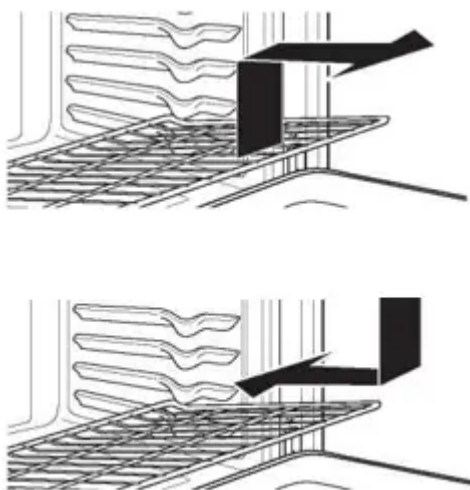

## Aluminum Foil and Oven Liners

Foil may be used to catch spills by placing a sheet on a lower rack, several inches below the food. Do not use more foil than necessary and never entirely cover an oven rack with aluminum foil. Keep foil at least 1-1/2" from oven walls to prevent poor heat circulation

## Cookware

### Cookware Guidelines

The material, finish, and size of cookware affect baking performance.

Dark, coated and dull pans absorb heat more readily than light, shiny pans. Pans that absorb heat more readily can result in a browner, crisper, and thicker crust. If using dark and coated cookware check food earlier than minimum cook time. If undesirable results are obtained with this type of cookware consider reducing oven temperature by 25° F next time.

Shiny pans can produce more evenly cooked baked goods such as cakes and cookies.

Glass and ceramic pans heat slowly but retain heat well. These types of pans work well for dishes such as pies and custards.

Air insulated pans heat slowly and can reduce bottom browning.

Keep cookware clean to promote even heating.

## Cooking Modes

Your new oven has a variety of cooking modes to help you get the best results. These modes are described below. Refer to the Cooking Guide section for recommendations for specific foods. Remember, your new oven may perform differently than the oven it is replacing.

### Baking Mode

When preparing baked goods such as cakes, cookies, and pastries always preheat the oven first. Follow recipe recommendations for food placement. If no guidelines are provided, center food in the oven.

### Traditional Bake

The traditional bake mode is intended for single rack cooking. This mode uses heat primarily from the lower element but also from the upper element to cook food.

To use this mode press the **Bake** pad, use the +/- pads to set the desired temperature, and then press **Start**. Preheating is generally recommended when using this mode.

### Broiling Mode

Always broil with the door open. Monitor food closely while broiling. Use caution when broiling on upper rack positions as placing food closer to the broil element increases smoking, spattering, and the possibility of fats igniting. For best performance center food below the broil heating element.

**Broiling on top rack is not recommended.**

Try broiling foods that you would normally grill. Adjust rack positions to adjust the intensity of the heat to the food. Place foods closer to the broil element when a seared surface and rare interior is desired. Thicker foods and foods that need to be cooked through should be broiled on a rack position farther from the broiler or by using **Broil Lo**.

### Broil Hi

The Traditional Broil Hi mode uses intense heat from the upper element to sear foods. Use Broil Hi for thinner cuts of meat and/ or foods you prefer less done on the interior. To use this mode press the **Broil** pad once and then press **Start**. It is not necessary to preheat when using this mode.

### Broil Lo

The Traditional Broil Lo mode uses less intense heat from the upper element to cook food thoroughly while also producing surface browning. Use Broil Lo for thicker cuts of meat and/or foods that you would like cooked all the way through. To use this mode press the **Broil** pad **twice** and then press **Start**. It is not necessary to preheat when using this mode.

# CARE AND CLEANING

## Cleaning the Range – Exterior

Be sure all controls are off and all surfaces are cool before cleaning any part of the range

### Control Panel

It's a good idea to wipe the control panel after each use. Clean with mild soap and water or vinegar and water, rinse with clean water and polish dry with a soft cloth.

Do not use abrasive cleansers, strong liquid cleansers plastic scouring pads or oven cleaners on the control panel—they will damage the finish.

### Control Knobs

The control knobs may be removed for easier cleaning. Make sure the knobs are in the Off positions and pull them straight off the stems for cleaning.

The knobs can be cleaned in a dishwasher or they may also be washed with soap and water. Make sure the insides of the knobs are dry before replacing.

Replace the knobs in the Off position to ensure proper placement

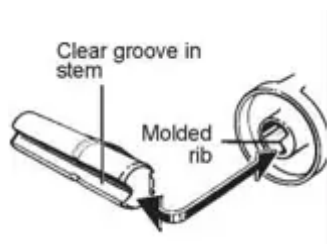

### Oven Vent

The oven is vented through an opening under the right rear surface unit. Never cover the opening with aluminum foil or any other material



### Oven Exterior

Do not use oven cleaners, abrasive cleansers, strong liquid cleansers, steel wool, plastic scouring pads, or cleaning powders on the interior or exterior of the oven. Clean with a mild soap and water

or vinegar and water solution. Rinse with clean water and dry with a soft cloth. When cleaning surfaces, make sure that they are at room temperature and not in direct sunlight.

If stain on the door vent trim is persistent, use a mild abrasive cleaner and a sponge-scrubber for best results. Spillage of marinades, fruit juices, tomato sauces and basting liquids containing acids may cause discoloration and should be wiped up immediately. Let hot surfaces cool, then clean and rinse.

### **Painted Surfaces**

Painted surfaces include the sides of the range and the door, top of control panel and the drawer front. Clean these with soap and water or a vinegar and water solution.

Do not use commercial oven cleaners, cleaning powders, steel wool or harsh abrasives on any painted surface

### **Porcelain Enamel Cooktop**

The porcelain enamel finish is sturdy but breakable if misused. This finish is acid-resistant. However, any acidic foods spilled (such as fruit juices, tomato or vinegar) should not be permitted to remain on the finish.

If acids spill on the cooktop while it is hot, use a dry paper towel or cloth to wipe it up right away. When the surface has cooled, wash with soap and water. Rinse well.

For other spills such as fat splatterings, wash with soap and water or cleansing powders after the surface has cooled. Rinse well. Polish with a dry cloth

### **Surface Units**

To clean the surface units, turn the control to the highest setting for a minute. The coils will burn off any soil.

#### **To remove a surface unit:**

To remove the drip pans for cleaning, the surface units must be removed first.

Lift the surface unit about 1 inch above the drip pan and pull it out.

Do not lift the surface unit more than 1 inch. If you do, it may not lie flat on the drip pan when you plug it back in. **NOTE:** Repeated lifting of the surface unit more than 1 inch above the drip pan can permanently damage the receptacle.

#### **To replace a surface unit:**

1. Replace the drip pan into the recess in the cooktop. Make sure the opening in the pan lines up with the receptacle.

2. Insert the terminals of the surface unit through the opening in the drip pan and into the receptacle.

3. Guide the surface unit into place so it rests evenly.

Do not immerse the surface units in liquids of any kind. Do not clean the surface units in a dishwasher.

Do not bend the surface unit plug terminals.

Do not attempt to clean, adjust or in any way repair the plug-in receptacle.

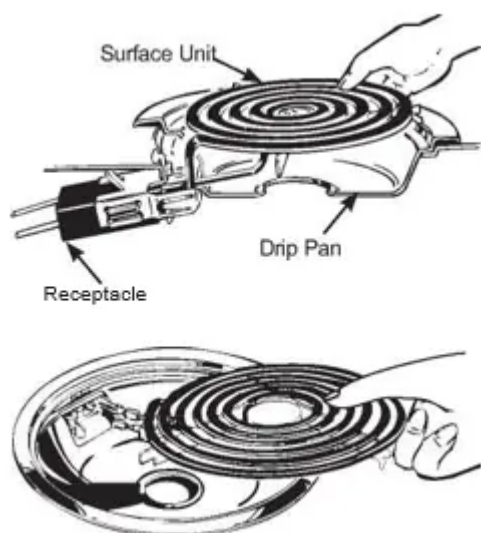

## Drip Pans

Remove the surface units. Then lift out the drip pans.

For best results, clean the drip pans by hand. Place them in a covered container (or a plastic bag) with  $\frac{1}{4}$  cup ammonia to loosen the soil. Rinse with clean water and polish with a clean soft cloth.

The drip pans may also be cleaned in a dishwasher. Clean the area under the drip pans often.

Built-up soil, especially grease, may catch fire.

Do not cover the drip pans with foil. Using foil so close to the receptacle could cause shock, fire or damage to the range.

**NOTE:** If your cooktop is equipped with shiny, silver-colored drip pans, do not clean them in the self-cleaning oven. Permanent damage to the finish can occur.

## Lift-Up Cooktop

The entire cooktop may be lifted up and supported in the up position for easier cleaning.

The surface units do not need to be removed; however, you may remove one to make raising the cooktop easier. There are two side supports that lock into position when the cooktop is lifted up.

After cleaning under the cooktop with hot, mild soapy water and a clean cloth, lower the cooktop. Be careful not to pinch your fingers

To lower the cooktop, push the rods back and gently lower the cooktop until it rests in place.

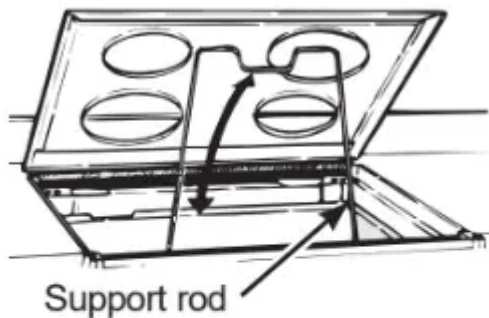

Be sure all surface units are turned off before raising the Cooktop.

## Cleaning the Range - Interior

The interior of your new oven can be cleaned manually or by using Steam Clean or Self Clean modes.

Spillage of marinades, fruit juices, tomato sauces and basting liquids containing acids may cause discoloration and should be wiped up immediately. Let hot surfaces cool, then clean and rinse.

### Manual Cleaning

Do not use oven cleaners, abrasive cleaners, strong soap and water or vinegar and water solution. Rinse with liquid cleansers, steel wool, scouring pads, or cleaning clean water and dry with a soft cloth. When cleaning powders on the interior of the oven. Clean with a mild surfaces, make sure that they are at room temperature

### Self Clean Mode

Read Self-Cleaning Oven Safety Instructions at the beginning of this manual before using Self Clean Mode. Self clean uses very high temperatures to clean the oven interior. You will need to lock the oven door when using this feature. Before operating the self-clean cycle, wipe up grease and soils from the oven. Remove all items from the oven. Shiny or silver racks and any cookware or other items should all be removed from the oven before initiating a self-clean cycle. Close the door. Latch the door.



**NOTE:** Never force the latch. If the oven is too hot, you will not be able to slide the latch. Allow the oven to cool. Press the Self Clean pad and a default self-clean time is displayed. The clean time can be changed to any time between 3:00 and 5:00 hours by using the +/- pads to enter a different time and pressing Start. For heavily soiled ovens, the maximum 5 hour clean time is recommended. If you wish to use the default time, press the Start pad immediately after pressing the Self Clean pad. The oven will turn off automatically when the selfclean cycle is complete and the self-clean light will be off. Slide the latch handle to the left as far as it will go and open the door. Never force the latch handle. Forcing the handle will damage the door lock mechanism. After the oven has cooled down wipe any ash out of the oven.

We recommend venting your kitchen with an open window or using a ventilation fan or hood during the first self-clean cycle.

Soil on the front frame of the range and outside the gasket on the door will need to be cleaned by hand. Clean these areas with hot water, soap-filled steel-wool pads or cleansers such as Soft Scrub®. Rinse well with clean water and dry.

Do not clean the gasket. The fiberglass material of the oven door gasket cannot withstand abrasion. It is essential for the gasket to remain intact. If you notice it becoming worn or frayed, replace it.

Make sure the oven light bulb cover is in place and the oven light is off.

**IMPORTANT:** The health of some birds is extremely sensitive to the fumes given off during the self-cleaning cycle of any range. Move birds to another well-ventilated room.

### **To Stop a Self-Clean Cycle**

Press **Cancel/Off** and wait for self clean light to go off. Wait until the oven has cooled below the locking temperature to unlatch the door. You will not be able to open the door right away unless the oven has cooled below the locking temperature.

### **Flat Racks**

Flat racks can be left in the cavity during self-clean (if enameled racks, not shiny) or can be washed with warm, soapy water.

Racks may be more difficult to slide, especially after a self-clean. Put some vegetable oil on a soft cloth or paper towel and rub onto the left and right edges.

**NOTE:** Using other cooking oils will cause a discoloring or a rust like color residue on the racks and cavity sides. To clean this residue, use a soap and water or a vinegar and water solution. Rinse with clean water and dry with a soft cloth.

### **Oven Heating Elements**

Do not clean the bake element or the broil element. Any soil will burn off when the elements are heated.

To clean the oven floor, gently lift the bake element. Clean with warm, soapy water.

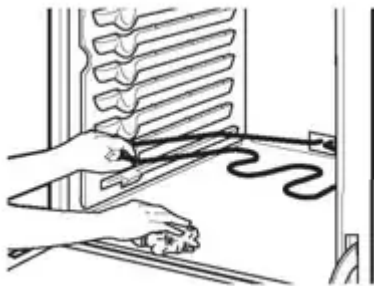

### **Oven Light**

#### **Oven Light Replacement**

##### **To remove:**

1. Hold a hand under the cover so it doesn't fall when released. With fingers of the same hand, firmly push

back the wire cover holder. Lift off the cover.

Do not remove any screws to remove the cover.

2. Replace bulb with a 40-watt appliance bulb.

##### **To replace:**

1. Place it into groove of the light receptacle. Pull wire forward to the center of the cover until it snaps into place.

2. Reconnect electrical power to the oven.

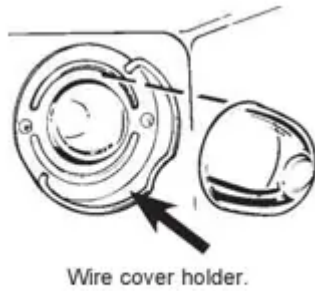

## Oven Door

The door is very heavy. Be careful when removing and lifting the door.

Do not lift the door by the handle.

### To remove the door: To clean the outside of the door:

Open it to the broil stop position. Grasp firmly on each side and lift the door straight up and off the hinges.

Do not place hands between the hinge and the oven door frame.

### To replace the door:

Make sure the hinges are in the broil stop position.

Position the slots in the bottom of the door squarely over the hinges and slowly lower it over both hinges.

### To clean the inside of the door:

- Because the area inside the gasket is cleaned during the self-clean cycle, you do not need to clean this by hand.
- The area outside the gasket and the front frame can be cleaned with a soap-filled steel wool or plastic pad, hot water and detergent. Rinse well with a vinegar and water solution

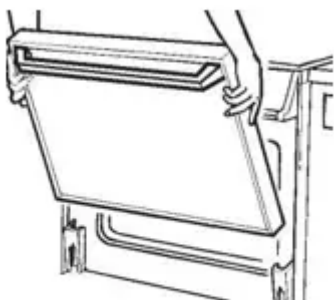

Lift the door straight up and off the hinges.

- Use soap and water to thoroughly clean the top, sides and front of the oven door. Rinse well. You may also use a glass cleaner to clean the glass on the outside of the door. Do not let water drip into the vent openings.
- Spillage of marinades, fruit juices, tomato sauces and basting materials containing acids may cause discoloration and should be wiped up immediately. When surface is cool, clean and rinse.
- Do not use oven cleaners, cleaning powders or harsh abrasives on the outside of the door.

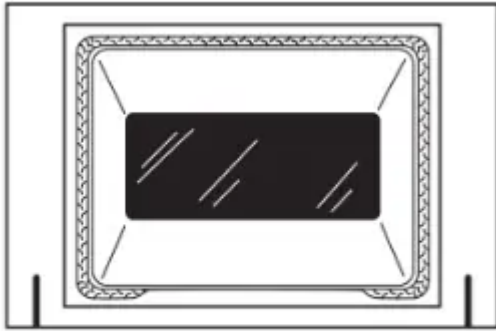

(appearance may vary)

The gasket is designed with a gap at the bottom to allow for proper air circulation

Do not rub or clean the door gasket—it has an extremely low resistance to abrasion.

If you notice the gasket becoming worn, frayed or damaged in any way or if it has become displaced on the door, you should have it replaced

## **TROUBLESHOOTING TIPS.**

<b>Problem</b>	<b>Possible Cause</b>	<b>What To Do</b>
<b>Surface units will not maintain a rolling boil or cooking is not fast enough.</b>	<b>Improper cookware being used.</b>	<b>Use pans which are flat and match the diameter of the surface unit selected.</b>
	<b>In some areas, the power (voltage) may be low.</b>	<b>Cover pan with a lid until desired heat is obtained.</b>
<b>Cooktop feels hot.</b>	<b>Large pans hold heat.</b>	<b>Choose a pan that matches the size of the surface unit you are using.</b>
	<b>The oven vent is blocked.</b>	<b>Pans on the right rear surface unit block air flow from the oven vent and cause the cooktop to get hot.</b>
<b>Coil surface units do not work properly.</b>	<b>The surface units are not plugged in solidly.</b>	<b>With the controls off, check to make sure the surface unit is plugged completely into the receptacle</b>
	<b>The surface unit controls improperly set.</b>	<b>Check to see the correct control is set for the surface unit you are using.</b>
	<b>The drip pans are not set securely in the cooktop.</b>	<b>With the controls off, check to make sure the drip pan is in the recess in the cooktop and that the opening in</b>

		the pan lines up with the receptacle
	A fuse in your home may be blown or the circuit breaker tripped.	Replace the fuse or reset the circuit breaker
Frequent cycling off and on of surface units.	Improper cookware being used.	Use only flat cookware to minimize cycling.
My new oven doesn't cook like my old one. Is something wrong with the temperature settings?	Your new oven has a different cooking system from your old oven and therefore may cook differently than your old oven.	For the first few uses, follow your recipe times and temperatures carefully. If you still think your new oven is too hot or too cold, you can adjust the temperature yourself to meet your specific cooking preference.  <b>NOTE: This adjustment affects Bake temperatures; it will not affect Broil or Clean.</b>
Food does not bake properly	Oven controls improperly set.	See the Cooking Modes section.
	Rack position is incorrect or rack is not level.	See the Cooking Modes section and Cooking Guide.

	<b>Incorrect cookware or cookware of improper size being used.</b>	<b>See the Cookware section</b>
	<b>Oven temperature needs adjustment</b>	<b>See the Special Features section.</b>
	<b>Ingredient substitution</b>	<b>Substituting ingredients can change the recipe outcome</b>
<b>Food does not broil properly.</b>	<b>Oven controls improperly set.</b>	<b>Make sure you select the appropriate broil mode.</b>
	<b>Improper rack position being used.</b>	<b>See Cooking Guide for rack location suggestions.</b>
	<b>Food being cooked in a hot pan.</b>	<b>Make sure cookware is cool.</b>
	<b>Cookware not suited for broiling.</b>	<b>Use a pan specifically designed for broiling.</b>
	<b>Aluminum foil used on the broiling pan and grid has not been fitted properly and slit as recommended.</b>	<b>If using aluminum foil conform to pan slits.</b>
	<b>In some areas the power (voltage) may be low.</b>	<b>Preheat the broil element for 10 minutes</b>
	<b>Door not open to the broil stop position as recommended</b>	<b>Make sure door is open to broil stop when broiling</b>



Oven temperature too hot or too cold.	Oven temperature needs adjustment.	See the Special Features section.
Oven does not work or appears not to work.	A fuse in your home may be blown or the circuit breaker tripped.	Replace the fuse or reset the circuit breaker.
	Oven controls improperly set.	See the Oven Controls section.
	Oven is in Sabbath Mode.	Verify, that the oven is not in Sabbath Mode. See the Special Features section.
“Crackling” or “popping” sound.	This is the sound of the metal heating and cooling during both the cooking and cleaning functions	This is normal.
Why is my range making a "clicking" noise when using my oven?	Your range cycles the heating elements by turning relays on and off to maintain the oven temperature.	This is normal.
Clock and timer do not work.	A fuse in your home may be blown or the circuit breaker tripped.	Replace the fuse or reset the circuit breaker.

	<p>Plug on range is not completely inserted in the electrical outlet.</p>	<p>Make sure electrical plug is plugged into a live, properly grounded outlet.</p>
	<p>Oven controls improperly set.</p>	<p>See the Using the kitchen timer section.</p>
<p>Oven door is crooked</p>	<p>The door is out of position</p>	<p>Because the oven door is removable, it sometimes gets out of position during installation. To straighten the door, push down on the high corner.</p>
<p>Oven light does not work</p>	<p>Light bulb is loose or defective.</p>	<p>Tighten or replace bulb.</p>
	<p>Pad operating light is broken.</p>	<p>Call for service.</p>
<p>Oven will not self-clean</p>	<p>The temperature is too high to set a self-clean operation.</p>	<p>Allow the oven to cool and reset the controls</p>
	<p>Oven controls improperly set.</p>	<p>See the Cleaning the Oven section.</p>
<p>Excessive smoking during clean cycle.</p>	<p>Excessive soil or grease.</p>	<p>Press the Cancel/Off pad. Open the windows to rid the room of smoke. Wait until the LOCKED light goes off. Wipe up the excess soil</p>

		and reset the clean cycle.
Excessive smoking during broiling	Food too close to burner element.	Lower the rack position of the food.
Oven door will not open after a clean cycle.	Oven too hot	Allow the oven to cool below locking temperature.
Oven not clean after a clean cycle.	Oven controls improperly set.	See the Cleaning the Oven section.
	Oven was heavily soiled	Clean up heavy spillovers before starting the clean cycle. Heavily soiled ovens may need to self-clean again or for a longer period of time.
"LOCK DOOR" flashes in the display.	The self-clean cycle has been selected but the door is not closed.	Close the oven door.
DOOR LOCK  light is on when you want to cook.	The oven door is locked because the temperature inside the oven has not dropped below the locking temperature.	Press the Cancel/Off pad. Allow the oven to cool.
"F— and a number or letter" flash in the display.	You have a function error code.	Press the Cancel/Off pad. Allow the oven to cool for one hour. Put the oven back into operation

	<b>If the function code repeats.</b>	<b>Disconnect all power to the oven for at least 30 seconds and then reconnect power. If the function error code repeats, call for service.</b>
<b>Display goes blank</b>	<b>A fuse in your home may be blown or the circuit breaker tripped.</b>	<b>Replace the fuse or reset the circuit breaker</b>
	<b>The clock is turned off.</b>	<b>See the Special features section.</b>
	<b>Oven is in Sabbath Mode.</b>	<b>Verify that the oven is not in Sabbath Mode. See the Special Features section.</b>
<b>Clock flashes.</b>	<b>Power outage or surge.</b>	<b>Reset the clock. If the oven was in use, you must reset it by pressing the Cancel/Off pad, setting the clock and resetting any cooking function.</b>
<b>“Burning” or “oily” odor emitting from the vent.</b>	<b>This is normal in a new oven and will disappear in time.</b>	<b>To speed the process, set a self-clean cycle for a minimum of 3 hours. See the Cleaning the Oven section</b>

<p><b>Strong odor</b></p>	<p><b>An odor from the insulation around the inside of the oven is normal for the first few times the oven is used.</b></p>	<p><b>This is temporary and will go away after several uses or a self-clean cycle.</b></p>
<p><b>My oven door glass appears to be "tinted" or have a "rainbow" color. Is this defective?</b></p>	<p><b>No. The inner oven glass is coated with a heat barrier to reflect the heat back into the oven to prevent heat loss and keep the outer door cool while baking.</b></p>	<p><b>This is normal. Under certain light or angles, you may see this tint or rainbow color.</b></p>
<p><b>Sometimes the oven takes longer to preheat to the same temperature</b></p>	<p><b>Cookware or food in oven</b></p>	<p><b>The cookware or food in the oven will cause the oven to take longer to preheat. Remove items to reduce preheat time.</b></p>
	<p><b>Number of racks in oven.</b></p>	<p><b>Adding more racks to the oven will cause the oven to take longer to preheat. Remove some racks.</b></p>
<p><b>Unable to get the display to show "SF".</b></p>	<p><b>Oven control pads were not touched properly.</b></p>	<p><b>The BROIL HI/LO and BAKE pads must be touched at the same time and held for 3 seconds.</b></p>
<p><b>Control signals after entering cooking time or start time.</b></p>	<p><b>You forgot to enter a bake temperature or cleaning time.</b></p>	<p><b>Touch the BAKE pad and desired temperature or the</b></p>



		<b>SELF CLEAN pad and desired clean time</b>
<b>Oven racks are difficult to slide.</b>	<b>The shiny, silver-colored racks were cleaned in a self-clean cycle.</b>	<b>Apply a small amount of vegetable oil to a paper towel and wipe the edges of the oven racks with the paper towel. Do not spray with Pam® or other lubricant sprays.</b>
<b>Steam from the vent.</b>	<b>When using the ovens, it is normal to see steam coming out of the oven vents. As the number of racks or amount of food being cooked increases, the amount of visible steam will increase.</b>	<b>This is normal.</b>

**Warning**

This content is compiled from multiple sources and is provided for reference purposes only. It may not be complete or fully applicable to all situations. If you are unable to resolve your issue, please contact the product manufacturer or an authorized service provider for official support.

