

## Getting Started

### Features

- **The Google Assistant™ on Android TV™**

Press the Google Assistant button on your remote to do more on your TV with your voice. Ask Google to search for the latest blockbuster, stream shows, or open multiplayer games. Have it dim the lights by connecting smart home devices. Manage tasks and see your calendar. Or ask it questions and see the answers on your TV.

- **Google Play**

Google Play is your entertainment unbound. It brings together all of the entertainment you love and helps you explore it in new ways, anytime, anywhere. We've brought the magic of Google to music, movies, TV, books, magazines, apps and games, so you get more from your content every day.

- **DTV / Analog TV / CATV**

You can use your remote to select channels which are broadcast in digital format and conventional analog format. Also, cable and satellite subscribers can access their TV channels.

- **Information display**

You can display on the TV screen the title, contents (DTV only) and other information on the current program.

- **Autoprogram**

This unit automatically scans and memorizes channels available in your area, eliminating difficult setup procedures.

- **Parental controls**

This feature allows you to block children's access to inappropriate programs. ● Closed caption decoder Built-in closed caption decoder displays text for closed caption supported programs.

- **MTS / SAP tuner**

Audio can be selected from the remote.

- **Auto standby**

If there is no input signal and no operation for 15 minutes, the unit will go into standby mode automatically.

- **Sleep timer**

You can set the unit to go into standby mode after a specific amount of time.

- **Choices for on-screen language**

Select your on-screen language: English, Spanish or French.

- **Stereo sound function**

- **Various adjustments for picture and sound**

Customizes picture quality suitable for your room and sets your sound preference.

- **HDMI control**

HDMI control allows your other HDMI link devices to be controlled by the HDMI cable connected to your TV.

- **HDMI input**

- **HDMI-DVI input**

If your video device has a DVI output jack, use an HDMI-DVI conversion cable to connect the unit.

- **AV input**

Audio and video input from an external device.

- **Digital audio output**

- **Headphone audio output**

Headphone 3.5 mm stereo jack for personal listening.

### **Include Accessories**

Quick start guide



Safety instruction /  
Limited warranty



Caution sheet



TV base and screws \*



Remote and Batteries  
(AAA, 1.5 V x 2)

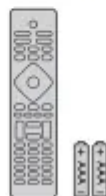

### **NOTE**

- If you lose the screws, please purchase the above-mentioned phillips head screws at your local store.

- If you need to replace these accessories, please refer to the part name or No. with the illustrations and call our toll free customer support line found on the cover of this user manual.

### **When using a universal remote to operate this unit.**

- Make sure the component code on your universal remote is set to our brand. Refer to the instruction book accompanying your remote for more details.
- We do not guarantee 100% interoperability with all universal remote.

### **Installing the stands**

1 Remove the tape on the bottom of the TV set and the plastic bag.

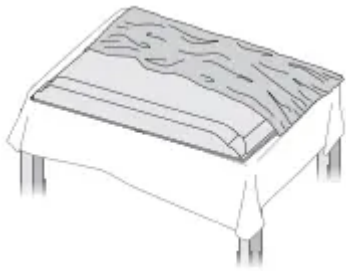

2 Fasten the stand to the TV with 4 screws.

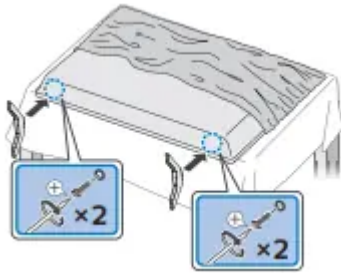

**NOTE:** While fastening the screws, hold the stand to prevent it from falling

3 Both stands should now be securely fastened.

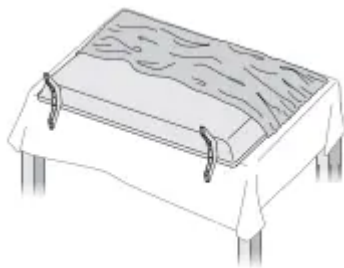

### **NOTE:**

- A wide open space is recommended for assembly.
- A Phillips-head screwdriver is required to fasten the stands to the TV set.

- When attaching the stand, ensure that all screws are tightly fastened. If the stand is not properly attached, it could cause the unit to fall, resulting in injuries as well as damage to the unit.
- To remove the stand from this unit, unscrew the phillips-head screws by reversing the procedure. Be careful not to drop the stand when you remove it.

### Lifting the TV set

Carefully lift the TV set as shown in the illustration and place it onto a stable, level surface

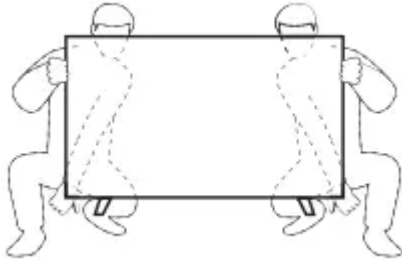

### Installing the Batteries

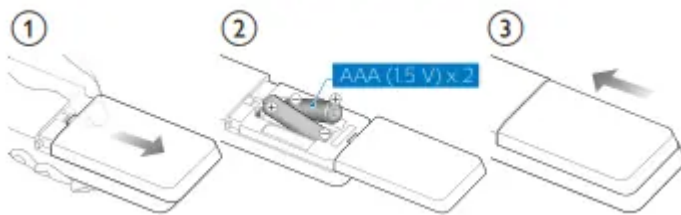

- 1 Open the battery cover by firmly sliding down.
- 2 Insert 2 AAA (1.5 V) batteries matching the polarity indicated inside battery compartment of the remote.
- 3 Slide the cover back into position.

### Remote



- ① **Microphone**
- ② **⏻ (POWER)**  
Turn the TV on/off into Quick Start Standby. Holding the button for 1 second or more will put the TV into Low Power Standby.
- ③ **SAP**  
Selects audio mode (MONO / STEREO / SAP) / audio language
- ④ **⏏ (FORMAT)**  
Adjusts the picture size on the TV screen.
- ⑤ **📺 (TV GUIDE)**  
Access to the Electronic Program Guide (EPG).
- ⑥ **← (BACK)**  
Returns to the previous menu screen.
- ⑦ **VOL + / -**  
Adjusts the volume.
- ⑧ **🔇 (MUTE)**  
Turns the sound on and off.
- ⑨ **CC**  
Selects closed caption settings.
- ⑩ **ℹ (INFO)**  
Displays input and resolution information.
- ⑪ **Google Assistant**  
Press the Google Assistant button on your remote to ask Google.
- ⑫ **☰ (OPTIONS)**  
Displays a list of menu options applicable to the active screen.
- ⑬ **OK**  
Press to decide the command of setting when the Home menu is displayed.
- ⑭ **▲ ▼ ◀ ▶ (NAVIGATION buttons)**  
Moves the cursor, selects the on-screen menu items.
- ⑮ **🏠 (HOME)**  
Access to your apps, Live TV, input devices, settings, and the Google Play Store.
- ⑯ **PREV.CH**  
Direct access to the Live TV channels.  
Displays the last selected terminal or channel.
- ⑰ **COLOR buttons**  
Works as direct access to user specified net apps.
- ⑱ **⏏ (INPUT)**  
Change input source.  
Select and change access to the attached devices such as Blu-ray player, gaming consoles, or cable box.
- ⑲ **CH + / -**  
Selects a channel.
- ⑳ **0 - 9 (NUMBER buttons)**  
Used to enter a channel / program number.  
• **(DOT)** : Use with **0-9** to select digital channels.  
For example, to enter 2.1, press
- ㉑ **EasyLink buttons**
  - ⏮ / ⏭ : Skips backward or forward chapters, titles or tracks on a disc.
  - : Stops the disc playback.
  - ⏪ / ⏩ : Searches backward or forward through the disc.
  - ▶ || : Starts, pauses or resumes playback

## Control panel

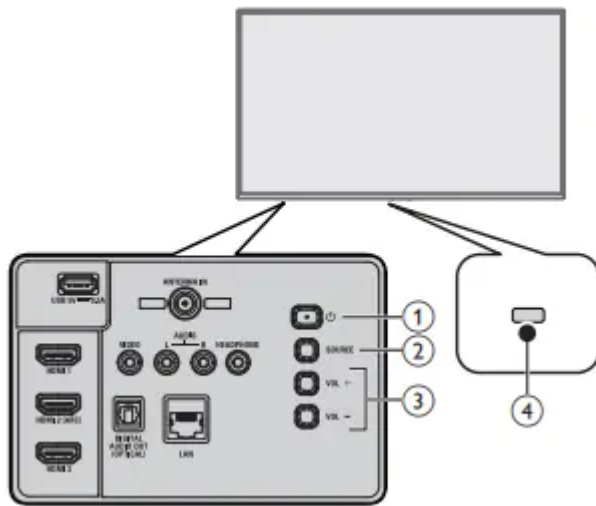

- ① **⏻ (POWER)**  
Turns the TV on or switches the TV into standby mode.  
Turns the TV on and off of standby.
- ② **SOURCE**  
Selects connected devices.
- ③ **VOL + / -**  
Adjusts the volume.  
**VOL +** : Volume up  
**VOL -** : Volume down
- ④ **Remote sensor**  
Receives IR signal from remote.

## Terminals

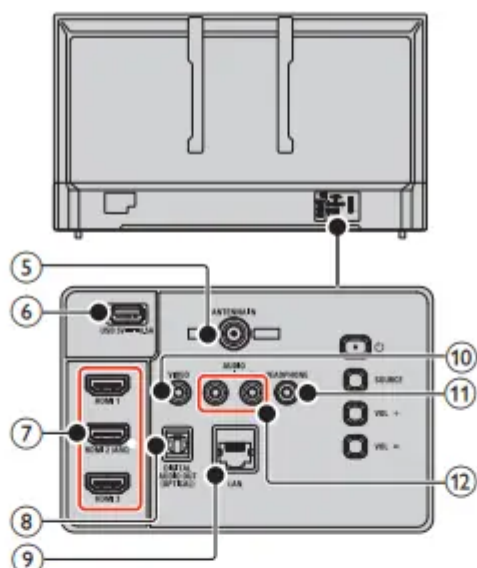

- ⑤ **75 ohm Cable / Antenna connection**  
Signal input from an antenna or Cable / Satellite set-top boxes.
- ⑥ **USB terminal**  
Data input from USB memory stick only.
- ⑦ **HDMI input jack(s)**  
Digital audio and video input from high definition digital devices such as DVD / Blu-ray Disc™ players, Soundbar / cable / satellite set-top boxes, PC's, etc.
  - HDMI-DVI / Analog audio (L/R) jacks signal
  - Composite video / Analog audio (L/R) jacks signal
  - PC connection / Analog audio (L/R) jacks signal with stereo mini 3.5 mm plug audio cable on PC
  - \* For HDMI 2 only : In addition to normal HDMI functionality, it outputs TV audio to an HDMI-ARC compliant device, such as a soundbar and home theater system.
- ⑧ **Digital audio output (Optical) jack**  
Digital audio (SPDIF) output to home theaters and other digital audio systems.
- ⑨ **Ethernet port**  
For internet connection using an Ethernet cable with an RJ-45 connector.
- ⑩ **Composite video (VIDEO) input jack**  
Connect composite analog video signal.
- ⑪ **Headphone audio output jack**  
Headphone 3.5 mm stereo jack for personal listening.
- ⑫ **Analog audio (L/R) input jacks**  
Connect analog audio signals from;
  - HDMI-DVI / Analog audio (L/R) jacks signal
  - Composite video / Analog audio (L/R) jacks signal
  - PC connection / Analog audio (L/R) jacks signal with stereo mini 3.5 mm plug audio cable on PC

## Connecting antenna or cable / satellite / IPTV set-top box

### If connecting to an antenna through an RF cable

Any DTV programs that are broadcast in your area can be received for free through an antenna connection.

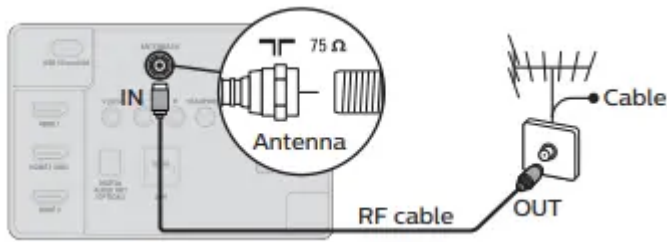

**If connecting cable / satellite / IPTV set-top box using an RF cable**

If the TV is connected to a cable / satellite set-top box via a coaxial connection, set the TV to channel 3/4 or the channel specified by the service provider.

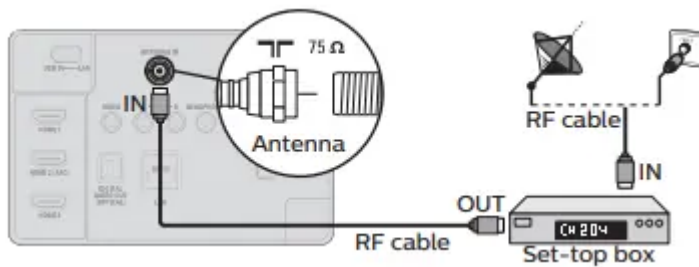

**If connecting cable / satellite / IPTV set-top box using an HDMI cable**

If the TV is connected to a cable / satellite set-top box via an HDMI cable, make sure you select the correct source by using  (INPUT).

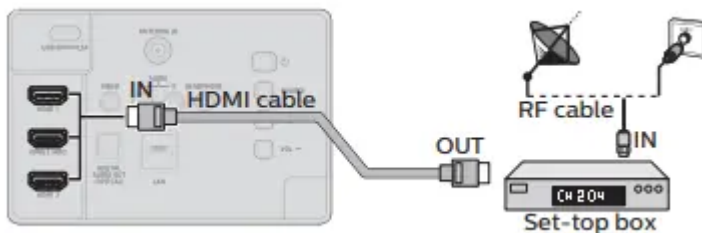

**Connecting a cable / satellite / IPTV set-top box, Bluray Disc™ / DVD recorder via composite connectors and analog audio**

Do not place your recorder too close to the screen because some recorders can be susceptible to harmful interference from the TV.



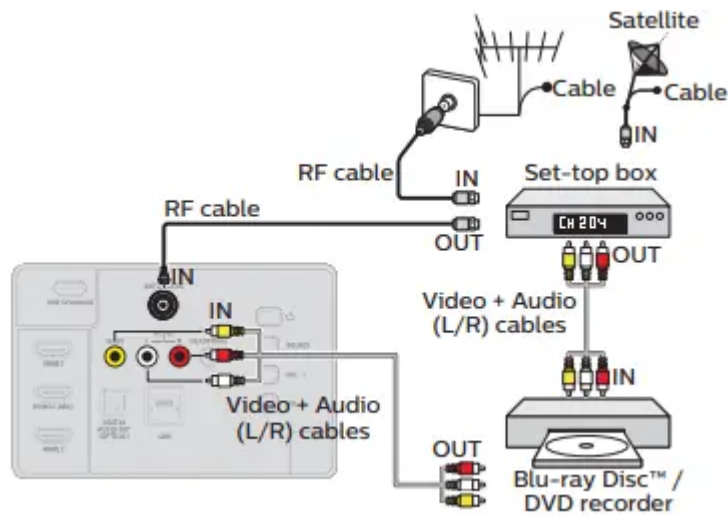

## Selecting your connection quality

### HDMI - Highest quality

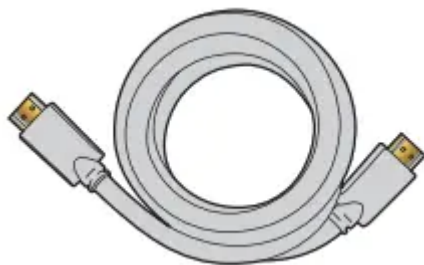

Supports high-definition digital signals and gives highest picture and sound quality. Video and audio signals are combined in one cable. You must use HDMI for full high-definition video and to enable HDMI control (HDMI CEC).

### Composite - Basic quality



For analog connections. Composite video / Audio analog cable usually combine a yellow video cable with red / white audio (L/R) cables.

## Connecting your devices

### HDMI digital connection

HDMI connection offers the highest picture quality. HDMI (High-Definition Multimedia Interface) transports highdefinition digital video and multi-channel digital audio through a single cable.

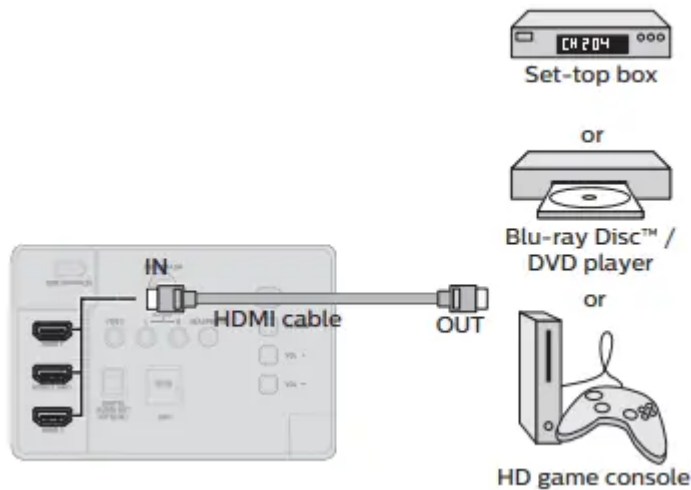

### HDMI-DVI connection

This unit can be connected to a device that has a DVI terminal. Use an HDMI-DVI conversion cable for this connection and it requires audio cable for analog audio signal as well.

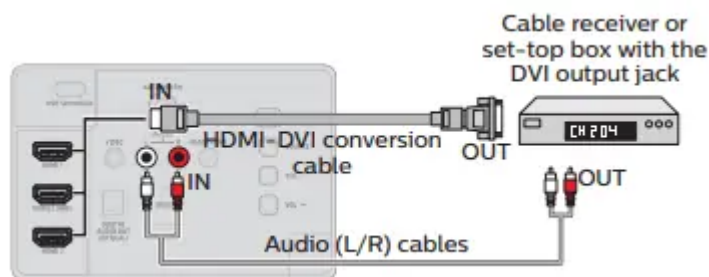

### HDMI-ARC connection

HDMI-ARC allows you to use HDMI control to output TV audio directly to a connected audio device, without the need for an additional digital audio cable.

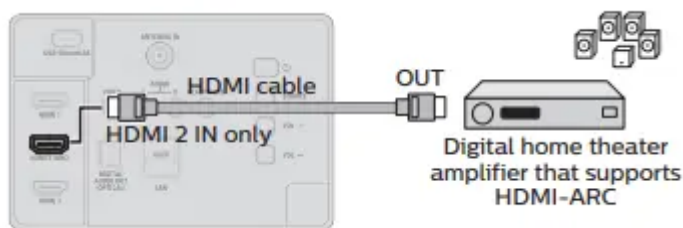

### HDMI EDID Version

If there are issues with picture/color and/or sound when connecting an external device using the HDMI port, please try switching the HDMI mode following the instructions below

- 1 Press **INPUT** to switch input device list.
- 2 Press **OPTIONS** on your remote and navigate to **Settings** and press **OK**.
- 3 Select **Device Preferences** and press **OK**.

4 Select Inputs and press **OK**.

5 Select **HDMI EDID Version** and press **OK**.

### Digital audio output connection

If you connect this unit to an external digital audio device, you can enjoy multi-channel audio like 5.1ch digital broadcasting sound. Use a digital audio optical cable to connect the unit to external digital audio devices.

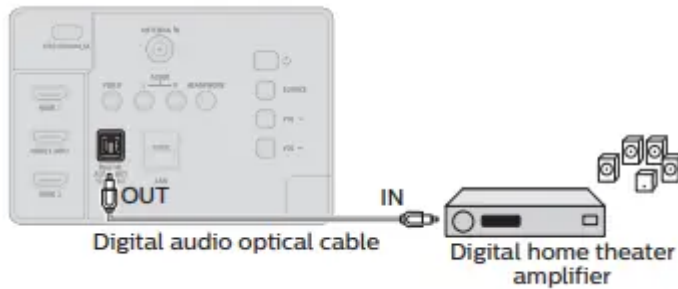

### Composite analog video connection

Composite analog video connection offers standard picture quality for video devices connected to the unit. If you connect to the unit's composite video (VIDEO) input jack, connect audio cables to the audio (L/R) input jacks. When the audio is monaural, then only connect to the audio L input jack.

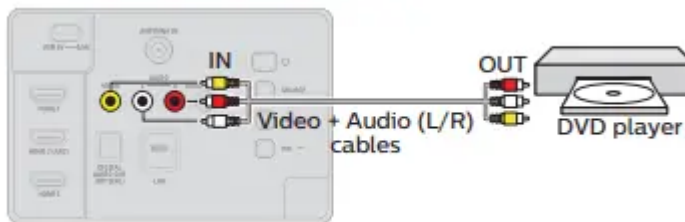

### Connecting the TV to the internet using an Ethernet cable

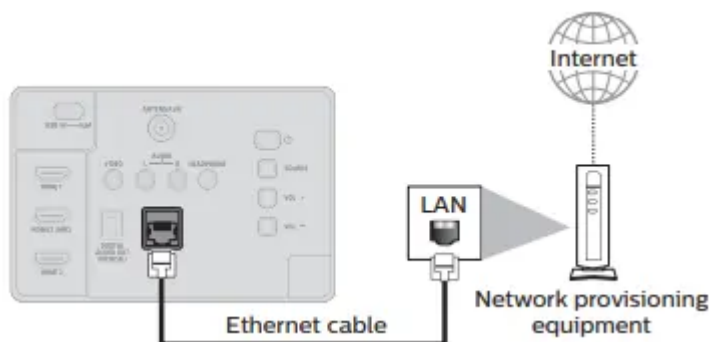

### Connecting the TV to the internet using a wireless LAN

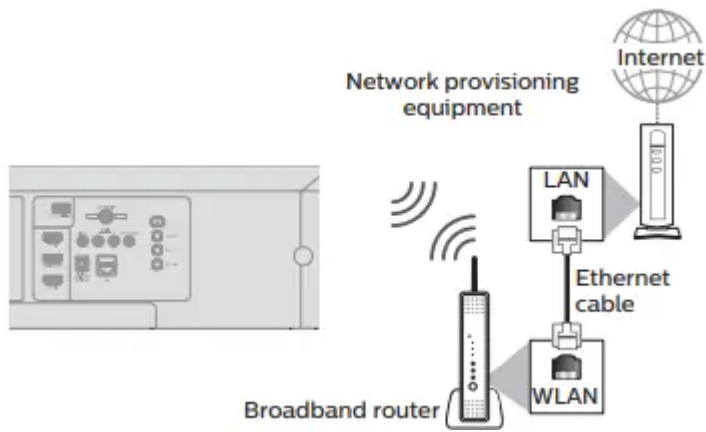

### PC connection

#### HDMI connection

This unit can be connected to your PC that has an HDMI terminal. Use an HDMI cable for this digital connection.

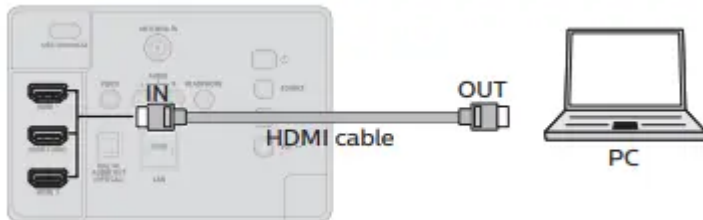

#### HDMI-DVI connection

This unit can be connected to your PC that has a DVI terminal. Use an HDMI-DVI conversion cable for this video digital connection and it requires stereo mini 3.5 mm plug audio cable for analog audio signal as well.

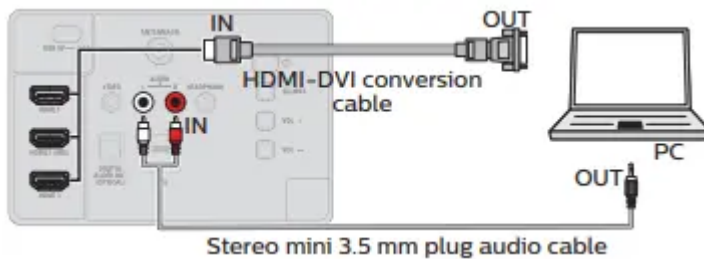

The following PC-input video signals can be displayed:



Format	Resolution	Refresh rate
VGA	640 x 480	60 Hz
SVGA	800 x 600	
WXGA	1,024 x 768	
	1,280 x 768	
FHD	1,920 x 1,080	24/30/60 Hz
UHD	3,840 x 2,160	
	4,096 x 2,160	

# Use your TV

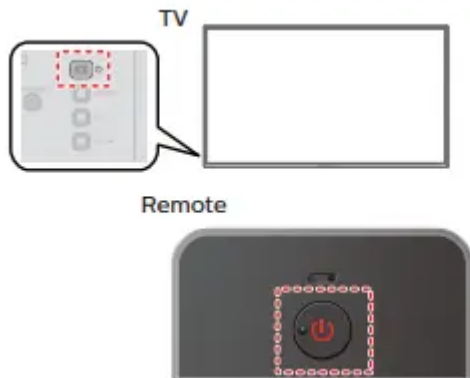
## Switching on your TV and putting it in standby mode





### Turns the TV on and off of standby.

- Press  (POWER) on the TV or the remote, then TV will go to suspend standby.
- Press and hold  (POWER) on the TV or the remote, then TV will go to standby mode completely.

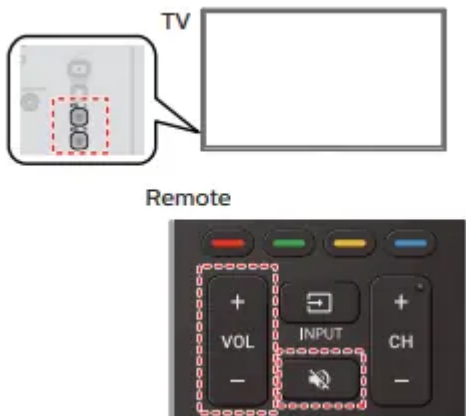
### Adjusting volume



### To decrease or increase volume

- Press VOL + / – on the TV or the remote.  
VOL + : Volume up  
VOL – : Volume down To mute or unmute sound
- Press 2  (MUTE) on the remote to mute the sound.
- Press 2  (MUTE) again or VOL + / – to recover the original sound.

### Switching channels



To change channels, you can do any of the following:

- Press CH + / – on the remote.
- Use the NUMBER buttons on the remote.
- Press ▲▼| on the remote for digital channels only.

### Watching channels from an external device

Switching each input mode can easily switch with the remote between TV and external devices when they are connected to the unit.

**Turn on the set-top box or the connected device.**



① Press  (INPUT) and use ▲▼| to select the set-top box or the connected device and wait a few seconds till the picture appears.

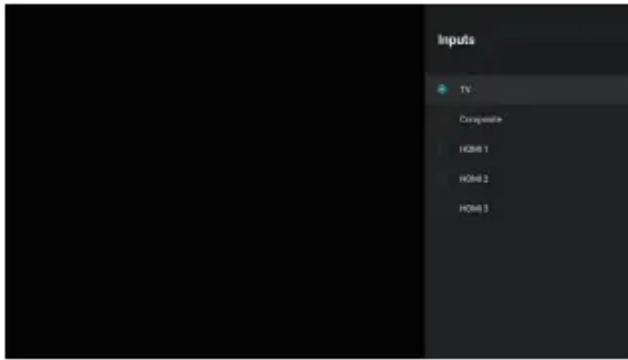

② Use the remote of the set-top box or the connected device to select channels.

### Access the Home menu



Press  (HOME).

### Guide to Home menu

From the Android TV home screen, you can easily access movies, TV shows, music, apps, input devices, settings, and more. To go back to the home screen at any time, press  (HOME) on your remote.

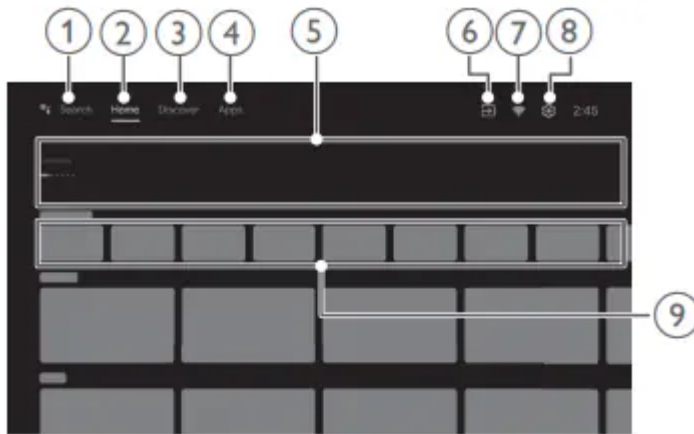

- ① **Google Assistant** : With the Google Assistant, quickly access entertainment, control smart devices, get answer on screen, and more using your voice.
- ② **Home screen tab**
- ③ **Discover tab** : Recommendations are shown by topic or theme. Recommendations are based on watch history, interests and new trends.
- ④ **Apps tab** : Apps gallery which pre-installed or you installed.  
You must sign in with a Google account to visit and download apps from the Google Play store.
- ⑤ **Highlights** : You can find suggestions of movies and shows to watch which are handpicked by Google Play's entertainment experts or sponsored by media partners.
- ⑥ **Inputs** : Toggle inputs between your favorite source devices and built-in RF tuner.
- ⑦ **Network condition** : Display the network status and open network settings if selected.
- ⑧ **Settings** : Configure your television settings and connect to wireless devices.
- ⑨ **How to organize your favorite apps** : Select the application and long press **OK** on your remote.  
To move,  
Select **Move** in the list, and press **OK**.  
Use **◀▶** to move left or right.  
Press **OK**.  
To delete,  
Select **Remove from favorites** in the list, and press **OK**.

## Apps

1 Press **HOME** and use **▲▼◀▶** to select Apps tab, then press OK.

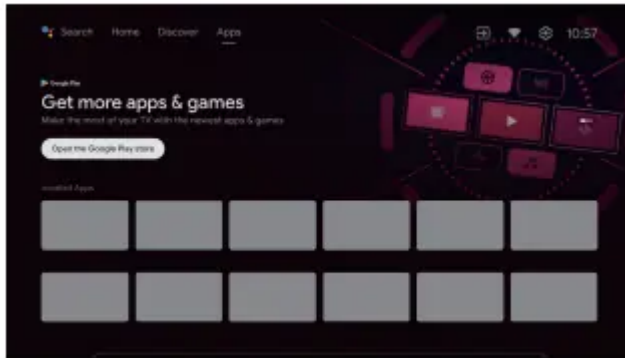

2 Select **Open the Google Play store** to open the Google Play Store apps.

3 Search for the app or type of app you want to install.

4 Select the app.

5 Select install.

### How to use Google Assistant with your remote

To use Google Assistant on your remote, make sure that the remote is connected via Bluetooth to the television. To check this, go to **Settings > Remotes & accessories** on your TV. If the remote is not connected, hold down the Volume (-) and Google Assistant button together for 3 seconds and select “Add accessory” in the menu.



You can start a conversation by simply pressing the Google Assistant button on your remote to ask Google a question or say a command. When activated by button, the Google Assistant dialog bar will appear at the bottom of your television screen.

### Microphone



1 Activating the Google Assistant on the home screen will launch a Google Query.

- Activating the Google Assistant within an app will allow you to search and find information only related to a specific app.

2 Speak into the microphone located on the top of your remote. Speech examples may be displayed depending on your model.

### Picture format

Display modes can be selected when your TV receives a 16:9 or 4:3 video signal. Press  (FORMAT) repeatedly to switch the TV aspect ratio.



### TV screen information

Press  (INFO).



### Using options menu

1 Press  (OPTIONS) to display options menu, then press **OK**.



2 Use  to select a desired setting, then press **OK**

## Getting more from your TV

1 Press  (HOME) to display the Home menu.



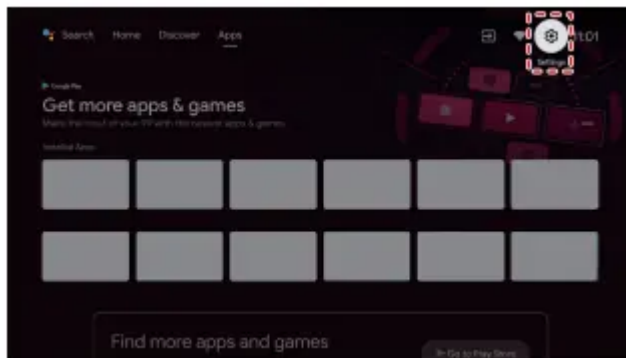

2 Use  to select **Settings**, then press **OK**.

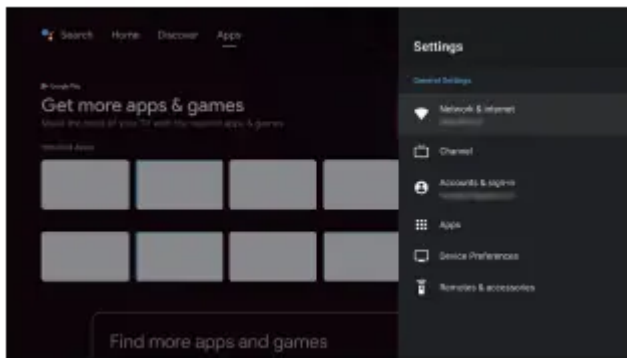

3 Use  to select the desired menu and an item, then press **OK**.



## Network & Internet

- 1 Press  (**HOME**) and use  to select **Settings** then press **OK**.
- 2 Use  to select **Network & Internet**, then press **OK**.

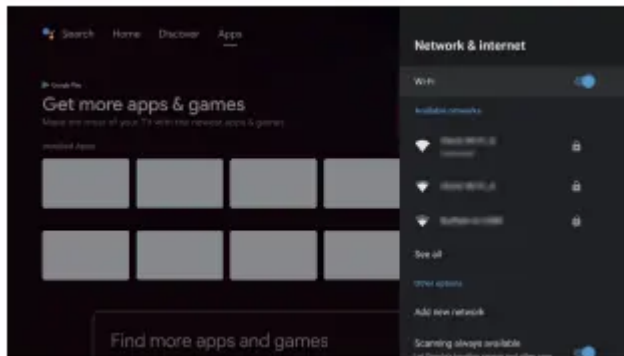

## Live TV/Antenna

### Add channels

To add for the first time or additional channels, please follow the steps below: \

- 1 On the Home menu, go to the **App tabs** and select **How to...**

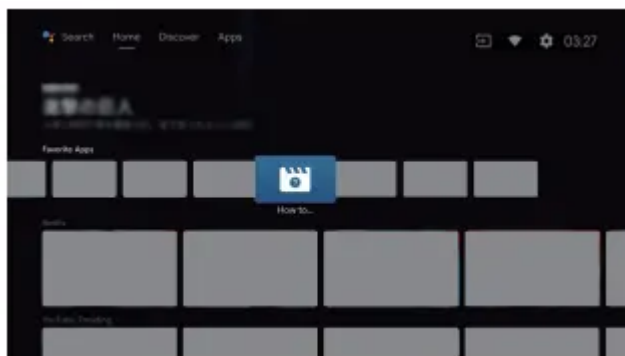

- 2 Select **Live TV** to open channel installation page. Once open, select **Setup** and press **OK**.
- 3 Select your signal type **Antenna / Cable** to start the channel installation.

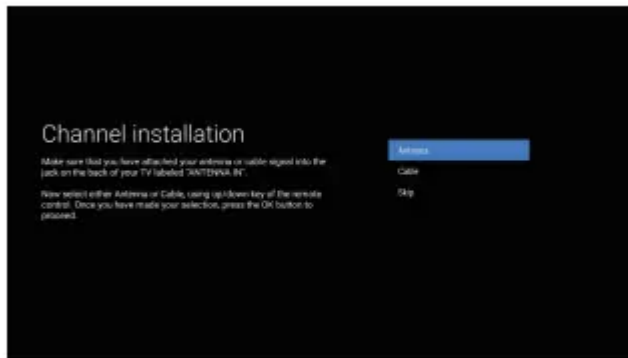

## Channel list

Press OK while viewing Live TV to open channel list.

## Program guide

To view the latest TV program schedule, press  (TV GUIDE) on your remote.

## Channel

1 When watching Live TV, then press  (**OPTIONS**).

2 Use  to select **Settings**, then press **OK**.

3 Use  to select **Channel**, then press **OK**.

## Parental Controls

You can restrict your children from watching certain programs or channels, by setting parental controls using a rating lock.

1 Use  to select **Parental Controls**, then press **OK**.

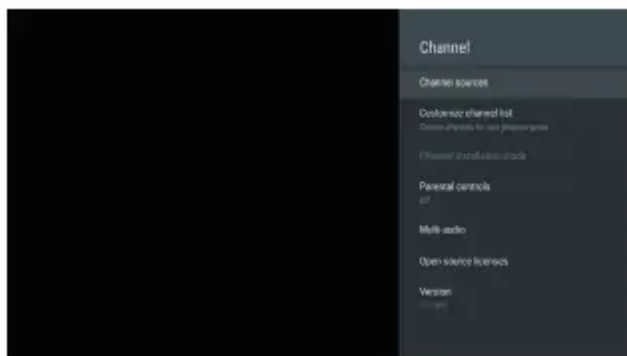

2 Use  to enter the 4-digit numbers for your PIN code.

- Default setting of PIN is “1234”.
- When the PIN code is correct, Parental Controls menu is displayed. See the following description for setting each item.

## Setting TV and film ratings

Film ratings lock is the rating system created by MPAA. TV ratings lock has controlled access to individual programs based on their age ratings and content rating.

3 Use ▲▼ to select **Program Restrictions**, then press **OK**.

4 Use ▲▼ to select **Ratings**, then press **OK** repeatedly to switch between block and view

United States (Film ratings)	United States	Description
-	TV-Y	Appropriate for all children
-	TV-Y7	Appropriate for all children 7 and older
G	TV-G	General audience
PG	TV-PG	Parental guidance suggested
PG-13	-	Unsuitable for children under 13
-	TV-14	Unsuitable for children under 14
R	-	Restricted under 17 requires accompanying parent or adult guardian
NC-17	-	No one under 17 admitted
X	TV-MA	Mature audience only

*Rating types and restriction levels*

<b>High restrictions</b>
Content suitable for children
<b>Medium restrictions</b>
Content suitable for older children
<b>Low restrictions</b>
Content suitable for teens

United States	High	Medium	Low
TV-Y			
TV-Y7	✓		
TV-G			
TV-PG	✓	✓	
TV-14	✓	✓	
TV-MA	✓	✓	✓

United States (Film ratings)	High	Medium	Low
G			
PG			
PG-13	✓	✓	
R	✓	✓	
NC-17	✓	✓	
X	✓	✓	✓

**Canadian English or Canadian French ratings**



You can select the rating for Canadian English or Canadian French broadcasting.

**Program Restrictions > Rating Systems** and check the Other Countries and Other Countries (French) checkboxes from the list. Otherwise Canada's rating will not be effective.



3 Use ▲▼ to select **Other Countries** or **Other Countries (French)**, then press **OK**.

4 Use ▲▼ to select the desired rating, then press **OK** repeatedly to switch between block and view.

-  indicates that the rating is locked (Blocked).
-  indicates that the rating is not locked (Viewable).

Other Countries	Other Countries (French)	Description
E		Exempt program
C	–	For all children
CB+	–	For all children 8 and older
G		General audience
–	8 ans+	Unsuitable for ages under 8
PG	–	Parental guidance suggested
–	13 ans+	Unsuitable for ages under 13
14+	–	Unsuitable for ages under 14
–	16 ans+	Unsuitable for ages under 16
18+	18 ans+	Adult audience only

### Change PIN

1 Use ▲▼ to select **Change PIN**, then press **OK**.

2 Use ▲▼ to enter the current 4-digit PIN code.

3 Use ▲▼ to enter the new 4-digit PIN code.

- Enter **PIN** code again to confirm.

### Language

You can set the language for the on-screen display.

1 Use ▲▼ to select **Language**, then press **OK**.

2 Use ▲▼ to select **English, Español or Français**, then press **OK**.

### Captions (Antenna / Cable)

Display	Off	Closed caption is not displayed.
	On	Closed caption is always displayed.
	CC w/ mute	Closed caption is displayed when the sound is off.

Caption service	CC-1 and T-1	The primary closed captions and text services. The closed captions or text is displayed in the same language as the program's dialog (up to 4 lines of script on the TV screen).
	CC-3 and T-3	Serve as the preferred data channels. The closed captions or text is often a secondary language.
	CC-2, CC-4, T-2 and T-4	Rarely available and broadcasters use them only in special conditions, such as when CC-1 and CC-3 or T-1 and T-3 are not available.

In addition to the basic closed caption, DTV has its own closed caption called digital caption service. Use this menu to change the settings for digital caption service.

Advanced selection	CS-1 to CS-6	Select one of these before changing any other item in <b>Captions (Antenna / Cable)</b> menu. Choose <b>CS-1</b> under normal conditions.
--------------------	--------------	---

## Troubleshooting tips

### Power

#### No power

- Make sure the AC power cord is plugged in.
- Make sure that the AC outlet supplies the proper voltage, plug another electrical appliance into the AC outlet to ensure that the AC outlet operates normally.
- If a power failure occurs, unplug the AC power cord for 1 minute to allow the unit to reset itself.

#### Slow start up

Your TV takes a long time to start up when you turn it on.

- When powering off the TV into Low Power Standby, there will be a longer load time when powering it back on.
- Press and hold the  (POWER) button for 1 second or more to go into Low Power Standby. Power consumption in this mode will be reduced ( $\leq 0.5$  W).

- Pressing the  (POWER) button for less than 1 second will put the TV into Quick Start Standby, which will have a quicker boot time when powering back on. Power consumption in this mode will be slightly higher.

## Remote

### Control buttons do not work.

- Do NOT press more than one button at the same time.
- Ensure that no buttons on the remote are depressed and move freely.
- Re-insert or replace the AAA batteries with their polarities (+/-) as indicated on the remote battery area.

### Universal remote does not work properly.

- Refer to the user manual of the universal remote for the Philips code.

### Remote buttons are not functional.

- Re-insert or replace the AAA batteries with their polarities (+/-) as indicated on the remote battery area.

### The Google Assistant button on your remote doesn't work

- Make sure the remote is connected to the TV via Bluetooth. Google Assistant uses Bluetooth to create a safe connection between the remote and TV. (See step “7 Connecting your devices” in the Quick start guide for details)
- Make sure the Google Assistant feature was activated during initial installation. To check this, go to Settings > Device Preferences > Google Assistant > Accounts to see if you are logged into an active account.

## Performance

### Remote response is delayed or sluggish during initial use.

- Your television is automatically, downloading and installing the latest applications, for the best user experience.
- During this time, you may experience a delayed response from your remote. Upon successful installation, your remote will operate normally.

## Accessibility

### Television is speaking prompts out-loud.

- To disable the TalkBack on your television, press  (HOME) on your remote, navigate to settings icon in the upper right corner of the home screen and select Device Preferences > Accessibility, select TalkBack, press OK to toggle between on or off.

## Picture

### **Power is on but screen image is off.**

- Check if the connection for your source device is properly secured.
- Check if the correct input is selected by pressing w (INPUT).
- Verify that your HDMI mode, for the input selected matches the resolution output of your source device. Change source input until you have picture and sound.

## Picture on HDMI Input

### **Television has sound with no picture or abnormal picture.**

- HDMI EDID Version setting is set to a different mode than your source device. To change it, refer to the step “7 Connecting your devices” in the Quick start guide and see “Changing input to devices that are connected to the TV”.
- Change the resolution output of your source device.

## Sound

### **No sound is heard when using the HDMI digital connection.**

- Some HDMI cables and devices may not be compatible with the TV due to different HDMI specifications.

### **No sound, distorted sound or incorrect audio sound is heard when using the HDMI-DVI connections.**

- Make sure that the analog audio signals from the HDMI-DVI device are connected to the analog audio input L/R jacks.
- When using Composite analog video, make sure that the analog audio (L/R) connectors are mounted into the audio (L/R) input jacks.

### **No sound from Soundbar / Home theater using an HDMI cable.**

- Please check to be sure the device is connected to the HDMI 2 (ARC) input on the TV.

### **Sound intermittent or no sound.**



- Check if the audio cable is connected into the unit correctly. You switch to a different input and the volume changes.
- This unit will memorize the volume level from the last time you adjusted it.
- If the volume of the sound from another device is higher or lower, then the loudness will change.
- Make sure **Auto Volume Control** is set to **On**.

## Picture & Sound

### No sound with distorted picture occurs when using the HDMI digital connection.

- Some HDMI cables and devices may not be compatible with the TV due to different HDMI specifications.

### No picture or sound

- Check if the power is on.
- Check whether all the cables to the unit are connected to the correct output jack on your separate device like Blu-ray Disc™ / DVD recorder.
- View other TV channels. The problem might be limited to the broadcasting station or weak signal strength.
- Unplug the AC power cord and wait for about 1 minute, then plug the AC power cord and turn on the unit again.
- Check whether the connection of the antenna or cable/satellite set-top box is connected correctly.
- Make sure that the selected input mode is connected to the working input jack.
- Make sure that the sound is not muted. Press  (MUTE) so that the volume bar and current volume level will appear on the TV screen.
- Make sure that the volume is NOT set to **0** or  (MUTE). If so, use **VOL + / -** to adjust to the desired volume.
- Make sure that the headphone is NOT connected to the headphone audio output jack.
- If there are issues with picture/color and/or sound when connecting an external device using the HDMI port, please try switching the **HDMI EDID Version**. (Refer to HDMI EDID)

### Adjusted Picture or Sound settings are not effective every time the unit is turned on.

- You need to turn off the **Retail Mode** setting. (Otherwise, the settings you adjusted will not be memorized after the unit goes into standby mode.)

### You see a distorted picture or hear an unusual sound. (Analog TV - NTSC signal)

- You may be getting NTSC (Analog) TV signal (not HDTV signal) interference from electrical appliances, automobiles, motorcycles or fluorescent lights.
- Try moving the unit to another location to see if this is the cause of the problem.
- Ghosts, lines or streaks in picture.
- Electrical interference from nearby appliances may affect picture quality.
- View other TV channels. The problem might be limited to the broadcasting station or weak signal strength.

### **Picture poor, sound intermittent or no sound**

- View other TV channels. The problem might be limited to the broadcasting station or weak signal strength.

### **Screen You switch to a different input and the screen size changes.**

- This unit will memorize the viewing mode from the last time you used the particular input modes.

### **The display image does not cover the entire screen.**

- If you are watching TV or using the composite video or HDMI with 480i input, select Picture format, and then switch to various screen modes.

### **Different color marks on the TV screen**

- View other TV channels. The problem might be limited to the broadcasting station, missing data or pixelation due to weak signal strength.

## **Screen**

### **You switch to a different input and the screen size changes.**

- This unit will memorize the viewing mode from the last time you used the particular input modes.

### **The display image does not cover the entire screen.**

- If you are watching TV or using the composite video or HDMI with 480i input, select **Picture format**, and then switch to various screen modes. (Refer to Picture format L p. 20)

### **Different color marks on the TV screen**

- View other TV channels. The problem might be limited to the broadcasting station, missing data or pixelation due to weak signal strength.

## **Closed captions**

### **Closed captions are displayed as a white box. No closed captions are displayed in the closed captions-supported program.**

- Interference from buildings or weather conditions may cause closed captions to be incomplete if watching analog TV signals.
- Broadcasting station may shorten the program to insert advertisements. The closed caption decoder cannot read the information of the shortened program.

### **Black box is displayed on the TV screen.**

- The text mode is selected for caption. Select CC-1, CC-2, CC-3 or CC-4.

## Software update

### **A message appears on the screen prompting for software update again.**

- When you start up the TV or a net service after executing the software update, a message may appear on the screen prompting for software update again. In this case, please execute the software update. (start from **Settings > Device Preferences > About > System update**)

## Network

### **Cannot connect to the network.**

- Check if your router and/or modem is properly connected.
- Check if the Ethernet cable connection between the TV and your router or modem is properly secured.
- Power cycle the router and/or modem.
- Check your network settings.

### **Sometimes video quality is poor when using the wireless LAN.**

- The wireless network connection quality varies depending on the distance or obstacles (e.g. wall, basement, 2nd floor) between the TV wireless LAN adapter and the wireless router (access point), from other wireless networks, and brand and type of the wireless router (access point). When using the wireless LAN of the TV, it is suggested to place the wireless router as close as possible to the television.

### **Wireless LAN connection fails or wireless connection is poor.**

- Check the installation location of the TV and wireless router (access point). Signal quality may be affected for the following reasons.
  - Interference of other wireless devices, microwaves, fluorescent lights, etc., are placed nearby.
  - –There are floors or walls between the wireless router and TV.
  - If the problems continue even after checking the above, try making a wired LAN connection.

### **Cannot use the wireless connection.**

- Check if the wireless LAN Access Point (AP) (e.g. wireless router) is oriented properly or not placed too close between them.
- Once you have activated the wireless connection please wait 30 seconds for the connection to be established after turning on the unit, before trying to access network features.

**Slow Data Connection or buffering.**

- Check the settings between your router and ISP modem or gateway (if applicable)
- Connect to a stable wireless connection from home wireless or wired network.
- The use of mobile hot spots or public wireless connections is not recommended

**Cannot use Netflix feature.**

- Check if the network connection is properly made.
- Visit **Netflix** on your PC and become a Netflix member.
- Some network services may not be available in your country.

**Cannot add movies or TV episodes to the Instant Queue.**

- Visit **Netflix** on your PC.

**Even though the speed of the internet connection improves during playback, the picture quality of Netflix streaming movie does not improve.**

- The picture quality does not change during playback. It differs depending on the speed of internet connection at the time of loading.

**Cannot use VUDU feature.**

- VUDU is available only in the United States.
- Check if the network connection is properly made.

**Cannot rent or buy movies / TV episodes on VUDU.**

- You need to activate the VUDU account.
- Log into your account and check your payment information.

**The picture quality of a streaming movie (Netflix or VUDU) is poor.**

- Check the speed of your internet connection. You need speeds of at least 8 Mbps to this player for high quality uninterrupted playback.

**Streaming movie (Netflix or VUDU) often stops or starts buffering during playback.**

- Contact your internet service provider to troubleshoot your internet connection for speed and line quality. Consistent line quality and speed are very important for internet video playback.

**Cannot connect to the network while my PC is connected to the network.**

- Check the content of your internet service contract to see if your internet service provider prevents multiple terminals connecting at the same time.

**Folder or files stored on home network media server are not displayed in the file list or cannot be played back.**

- Check the setting on your home media server. (Refer to the user manual of the home media server.)
- Check the network connection and settings

## **Google Duo**

### **USB camera does not work**

- Check if USB camera supports Android 9.0 or later. (May be listed on USB camera packaging or manufacturer's website)
- Check if USB camera is connected to the TV.
- Turn off the TV and disconnect/reconnect USB camera. Turn the TV back on and reopen the Duo app.
- If issues remain, please visit the Duo support page and check the Troubleshoot section

### **Other party cannot hear anything (My microphone does not work)**

- Check if USB camera has a built-in mic and supports Android 9.0 or later. (May be listed on USB camera packaging or manufacturer's website)
- Check if your microphone is muted. (Please unmute if so)
- Check if USB camera is connected to the TV.
- Turn off the TV and disconnect/reconnect USB camera. Turn the TV back on and reopen the Duo app.
- If issues remain, please visit the Duo support page and check the Troubleshoot section.

### **I cannot hear other party (Speaker does not work)**

- Check if the volume of the TV is muted or very low. (Please unmute or turn the volume up if so)
- Check if USB camera is connected to the TV.
- Turn off the TV and disconnect/reconnect USB camera. Turn the TV back on and reopen the Duo app.
- If issues remain, please visit the Duo support page and check the Troubleshoot section.

## Where can I find Google Duo app?

- Open the Google Play store and search “Google Duo”. From here, you can download or open the app. Once downloaded, you will be able to find it in the Apps tab in the home screen.

### Notes:

- *The LCD screen is manufactured to provide many years of useful life. Occasionally a few non active pixels may appear as a fixed point of blue, green or red. This is not to be considered a defect in the LCD screen.*
- *Some functions are not available in specific modes, but this is not a malfunction. Read the description in this manual for more details on correct operations.*

## Maintenance

### Cleaning

- Clean the front panel and other exterior surfaces of the unit with a soft microfiber cloth or lens brush. Before cleaning the panel, disconnect the AC power cord.
- Never use a solvent or alcohol. Do not spray insecticide liquid near the unit. Such chemicals may cause damage and discoloration to the exposed surfaces.
- Do not spray any liquids on the screen or other exterior surfaces of this unit. If liquids enter the unit, they could cause shorts, electric shocks or fire damage.



### Servicing

Should your unit become inoperative, do not try to correct the problem yourself. There are no user serviceable parts inside. Call our toll free customer support line found on the cover of this user manual to locate an authorized service center.

### IR signal check

If the remote is not working properly, you can use a digital or cell phone camera to see if it is sending out an infrared signal. e.g.) With a digital camera: Point the digital camera towards the remote infrared diode at the front of the remote. Press and hold any key on the remote and look at the camera display. If an infrared pulsating light appears on the display, the

remote is sending out an IR signal. Note: Some cameras may have an IR filter or dual camera cell phones may have an IR filter in one of the camera's and both will not display the IR signal.



## Specifications

Model #	55PFL5766		50PFL5766
<b>Picture</b>			
Type	UHD (Ultra HD) (3840 x 2160 pixels 60 Hz)		
Diagonal screen size / Aspect ratio	54.6" / 16:9	49.5" / 16:9	
Viewing angles	178° (V) by 178° (H)		
Built-in digital / analog tuner	ATSC (digital) / NTSC (analog)		
<b>Sound</b>			
Mono / Stereo	Mono, Stereo		
Power output (RMS watts)	10 W x 2		
Equalizer	5 band		
<b>Ease of use</b>			
Picture format	SD (4:3 source)	Automatic / Full / Unscaled / 4:3 / Movie expand	
	HD (16:9 source)		
	UHD		
<b>Channel</b>			
Channel coverage	Over-the-Air DTV (ATSC)	VHF: 2~13 UHF: 14~69 (Each channel may have e.g. 21~29, 31~39, etc)	
	Over-the-Air Analog (NTSC)	VHF: 2~13 UHF: 14~69	
CATV (Analog NTSC)	2~13, A~W W+1~W+94 (Analog W+1~W+84), A-5~A-1, 5A		
Tuning system	Channel frequency synthesized tuning system		
Channel access	Direct access number keyboard, Programmable scan and Channel + (up) / - (down)		
<b>Connectivity</b>			
Composite video input	1		
HDMI input	3 (selectable HDMI modes)		
	Supporting HDMI video signals : 480i/p, 720p, 1080i @60 Hz, 1080p, 2160p @24/30/60 Hz		
	Supporting HDMI HDR signals : HDR10, HLG (Hybrid Log-Gamma)		
	Supporting HDMI digital audio signals : LPCM, AC3, DD+ Supporting PC-input video signal up to 4096 x 2160		
Analog audio L/R input	1(L Audio / R Audio)		
PC input	Via HDMI and HDMI-DVI + Analog audio L/R		
USB	1		
Wireless LAN	Wireless LAN Supporting wireless standards : IEEE 802.11a/b/g/n/ac (2.4 GHz/5 GHz)		
Ethernet port	1		
Digital audio output	1 Supporting Dolby Audio		
Headphone output	1 1/8" (3.5 mm)		
Bluetooth	Version 5.0		
<b>Power</b>			
Power requirements	120 V~ +/- 10 %, 60 Hz +/- 0.5 %		
<b>Temperature</b>			
Operating temperature	41 °F (5 °C) to 104 °F (40 °C)		

### Warning

This content is compiled from multiple sources and is provided for reference purposes only. It may not be complete or fully applicable to all situations. If you are unable to resolve your issue, please contact the product manufacturer or an authorized service provider for official support.

---

Document generated by [ManualsFile](#)

