

STRUCTURE DIAGRAM

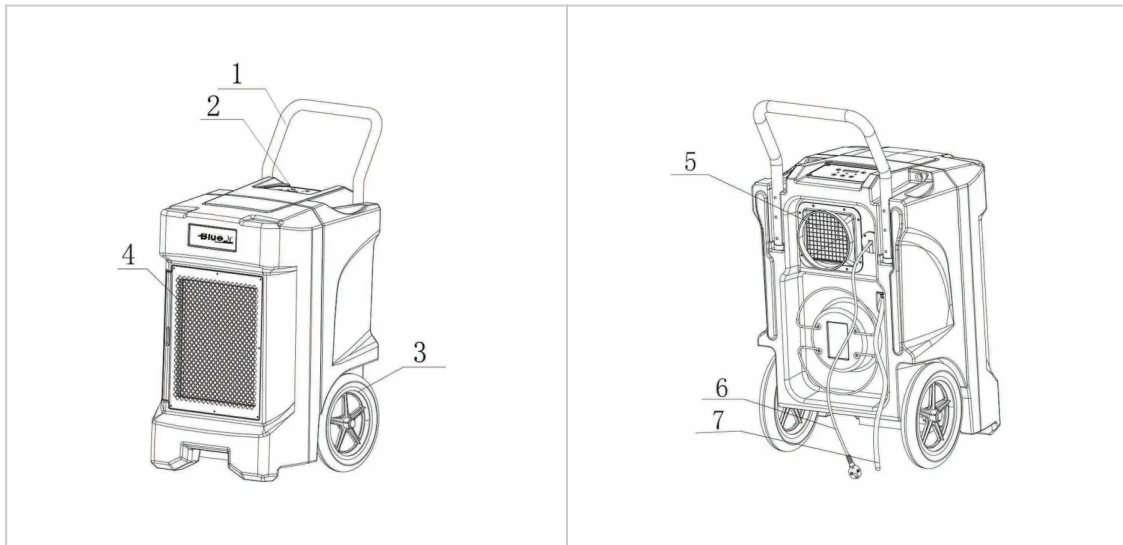

1. Handle
2. Control Panel
3. Wheel
4. Air Inlet Grille
5. Exhaust Grille
6. Power Cord
7. Water Pipe

WARNING DO NOT OBSTRUCT THE AIR INLET OR OUTLET.

SETTING UP THE DEHUMIDIFIER

Operate the dehumidifier in an enclosed area as this creates a drying chamber. Close all doors, windows or areas that open to external areas to maximize the dehumidifier's water removal efficiency. Keep traffic through the drying chamber to a minimum. Place the dehumidifier in the centre of the room away from walls and furnishings. DO NOT allow the airflows to be obstructed.

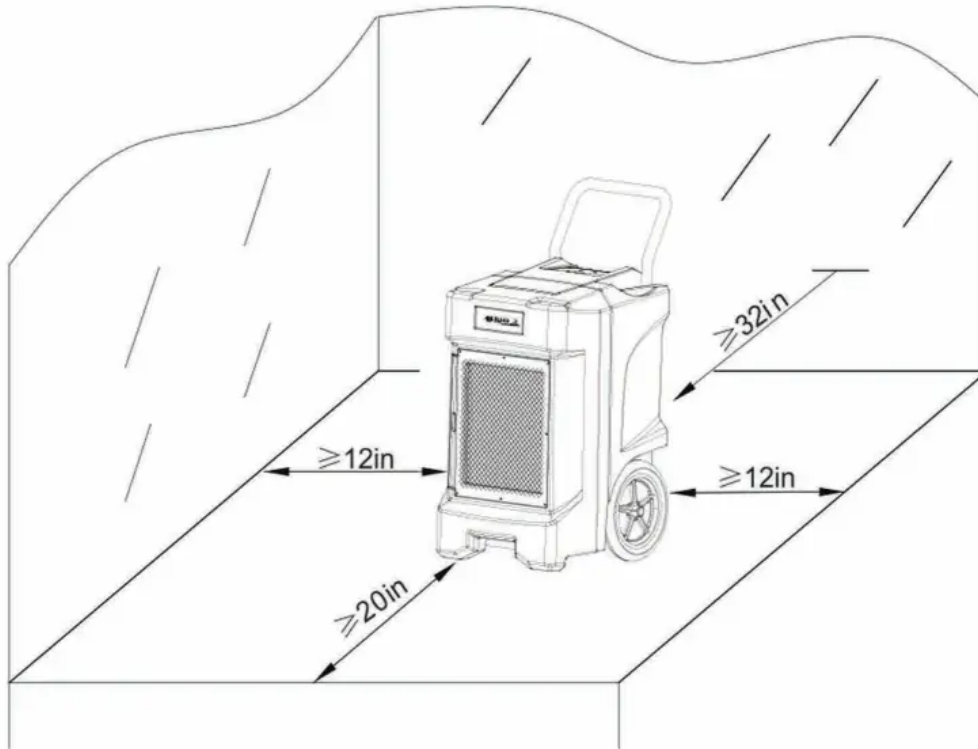

Illustration of correct positioning for best performance

DRAINAGE:

The dehumidifier pump connects to a plastic drainage hose. The hose is stored on the back of the appliance. Uncoil the entire hose ensuring there are no kinks or restrictions and place the unattached end into a water vessel or run to outdoors.

Ensure that water which runs to outdoors does NOT create a slip hazard.

Water vessels MUST be checked regularly when used.

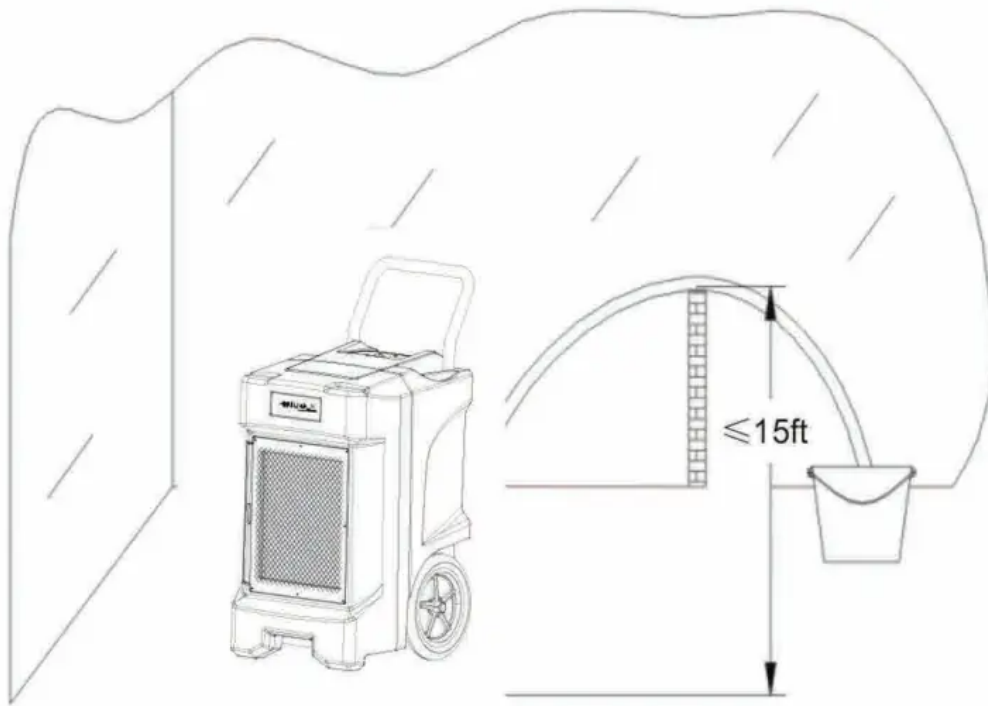

Note:

- The drain hose for the water pump can drain upto 15ft vertically. More than 15ft may cause water back up to the pump resulting in leakage.
- When turn off the unit, please take out the water pipe from bucket and empty water inside bucket to avoid the water back flow cause water leakage.

CONTROL PANEL

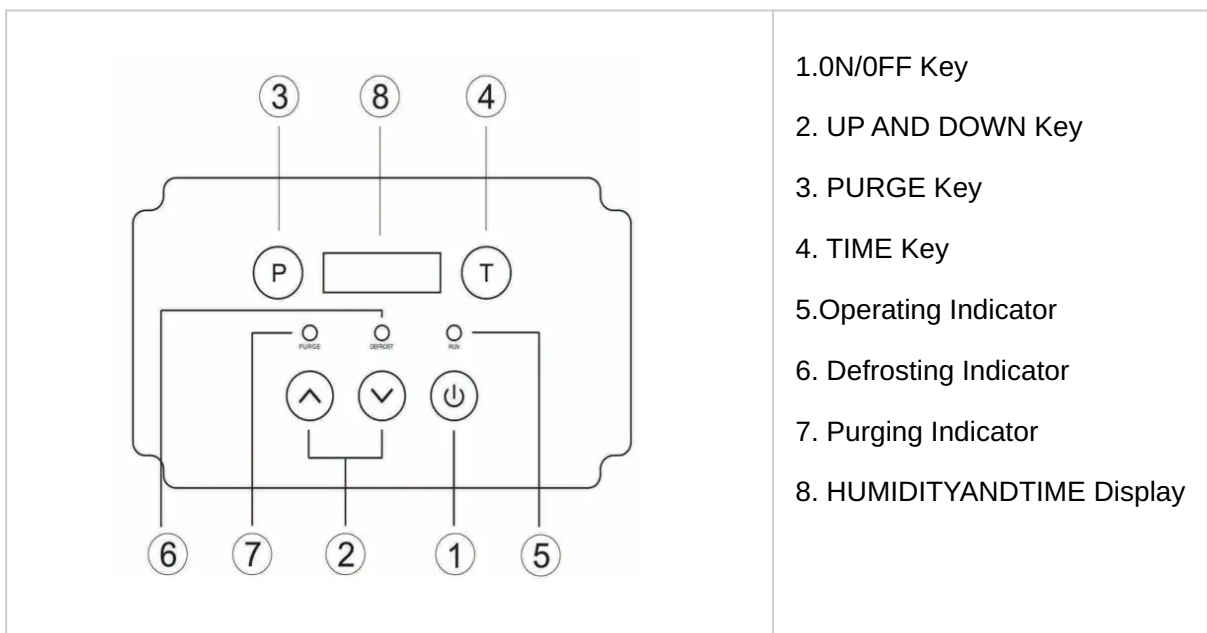



ON/OFF: Press the



key to turn the unit ON or OFF.



PURGE: Press the



key to empty water from the pump reservoir. During normal operation the pump purges automatically when the reservoir is full. Use "PURGE" before moving the machine to avoid water spillage. The pump will close automatically after 40 seconds of continuous operation.



and



: Press



and



key to set or adjust humidity in the range of 26% and 90%. When the environmental humidity is below 26%, "CO" will be displayed.

Defrost Indicator: The unit begins to defrost when the defrost indicator illuminates; the unit has stopped defrosting when the light is no longer illuminated. When defrosting is complete, the unit begins to dehumidify again automatically.



TIME: Press this to display working hours and total working time.

- Once the unit is running, the display will show the humidity setting (left) and current humidity (right). Humidity setting can be changed by pressing "Up" or "Down."
- Time settings are based on minutes. For example, if the display shows "0000:50," this means that the unit has worked for 50 minutes since powered on. If you want to view the total working time, press "T" again and the display will show this for 10 seconds, then return automatically to the original working hours. (Pressing "T" before the 10 seconds will return the display to the original working hours.)
- If the unit is powered on but not in operation, the LED will not display anything. If "T" is pressed once, the working hours from the previous time the unit ran will display for 10 seconds. Within the 10 seconds, if "T" is pressed again, the total working time will display for 10 seconds. If there is no action within those 10 seconds, the LED will automatically shut off.
- If "T" is pressed when LED displays the total working time, the LED will shut off immediately. The current working time will be deleted by pressing and holding down "T" for 5 seconds; the time will be reset, but the deleted time will be added into the total working time.

NOTE: The total working time cannot be deleted. If the time is beyond the range of what the LED can show, it will be deleted and restart from zero.

NOTE: If a power outage occurs while the unit is powered on, the unit automatically resumes operation at the most recent settings when power is restored.
vL/TIME: Press this to display working hours and total working time.

- Once the unit is running, the display will show the humidity setting (left) and current humidity (right). Humidity setting can be changed by pressing “Up” or “Down.”

- Time settings are based on minutes. For example, if the display shows “0000:50,” this means that the unit has worked for 50 minutes since powered on. If you want to view the total working time, press “T” again and the display will show this for 10 seconds, then return automatically to the original working hours. (Pressing “T” before the 10 seconds will return the display to the original working hours.)

- If the unit is powered on but not in operation, the LED will not display anything. If “T” is pressed once, the working hours from the previous time the unit ran will display for 10 seconds. Within the 10 seconds, if “T” is pressed again, the total working time will display for 10 seconds. If there is no action within those 10 seconds, the LED will automatically shut off.

- If “T” is pressed when LED displays the total working time, the LED will shut off immediately. The current working time will be deleted by pressing and holding down “T” for 5 seconds; the time will be reset, but the deleted time will be added into the total working time.

NOTE: The total working time cannot be deleted. If the time is beyond the range of what the LED can show, it will be deleted and restart from zero.

NOTE: If a power outage occurs while the unit is powered on, the unit automatically resumes operation at the most recent settings when power is restored.

OPERATING INSTRUCTIONS

Operation for general use:

Press the ON/OFF key to turn the unit on, it will get into working mode automatically.

After using, press ON/OFF key to turn the unit off, while water pump will turn on automatically for 40 seconds to drain the rest water, and turn off automatically.

Attention:

DO NOT switch the power **OFF** by disconnecting at the main socket outlet. To avoid water spillage; **DO NOT** move the dehumidifier for at least 3 minutes after turning the power **OFF**.

Key lock function

If the keys of “T” and “P” are pressed for 2s at the same time, the operating light will keep shining at the speed of 10Hz, and all the keys on the control panel will be in locked, it can be unlock by the same action again.

Vent hose function

As to a much wetter space, use a vent hose with diameter larger than 6.5in. Attach the vent hose to the exhaust ring (see below) to speed up drying the wet area.

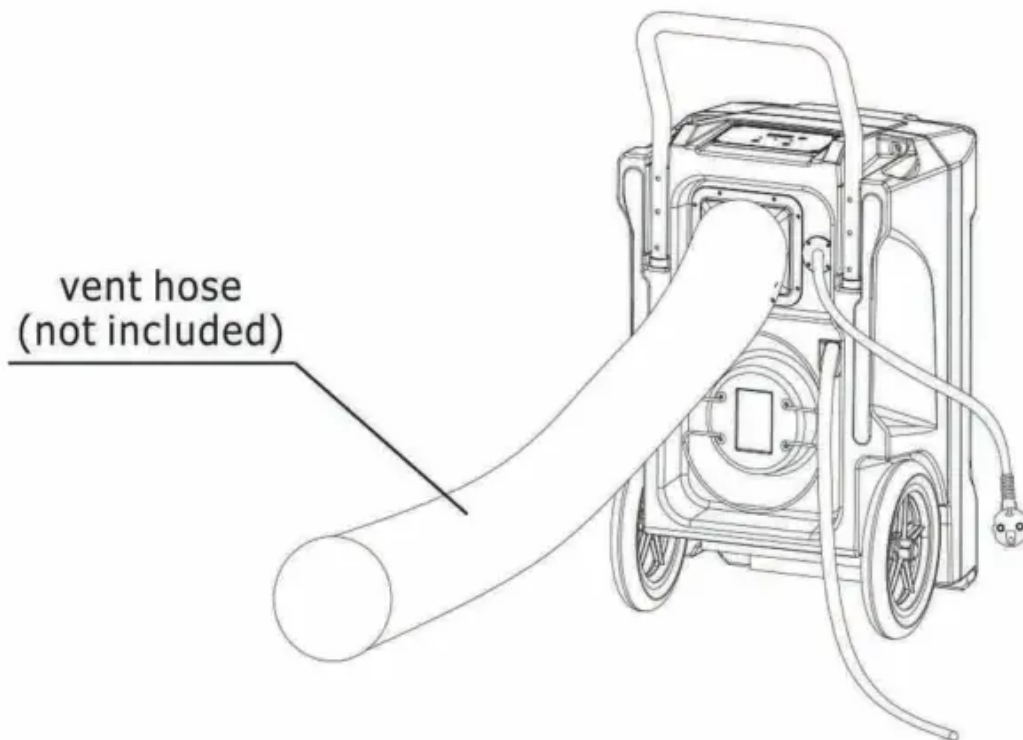

MAINTENANCE

CLEANING THE AIR FILTER

Ensure the dehumidifier is turned OFF and the plug is removed from the power socket before maintenance is carried out.

The working performance of the dehumidifier will be greatly reduced if the filters become blocked.

1. Remove the filter as shown in the diagram.
2. Vacuum any debris from the filter using the vacuum hose and nozzle attachment.
3. Using luke-warm water and a mild detergent wash the filter and allow to dry.
4. Once dry, re-install the filter into the dehumidifier.

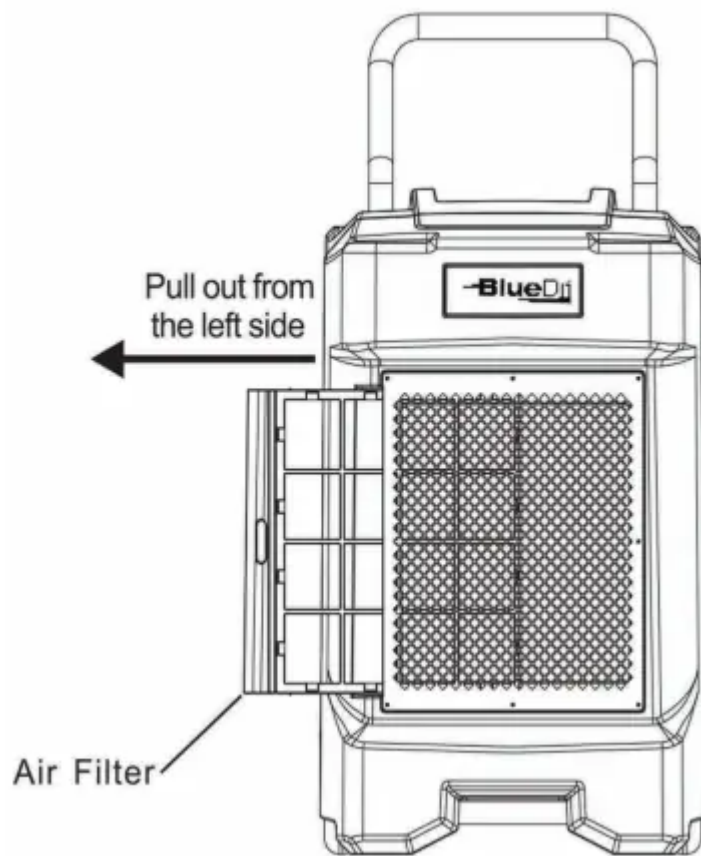

REPLACING THE BATTERY

1. Remove the screws in the four corners of the control panel.
2. Once the screws are removed, carefully lift the control panel to access the PCB.
3. On the PCB is a 9V 6F22 battery. Remove the battery and replace with a new battery.
4. Refit the control panel onto the PCB.
5. Refit the 4 screws.

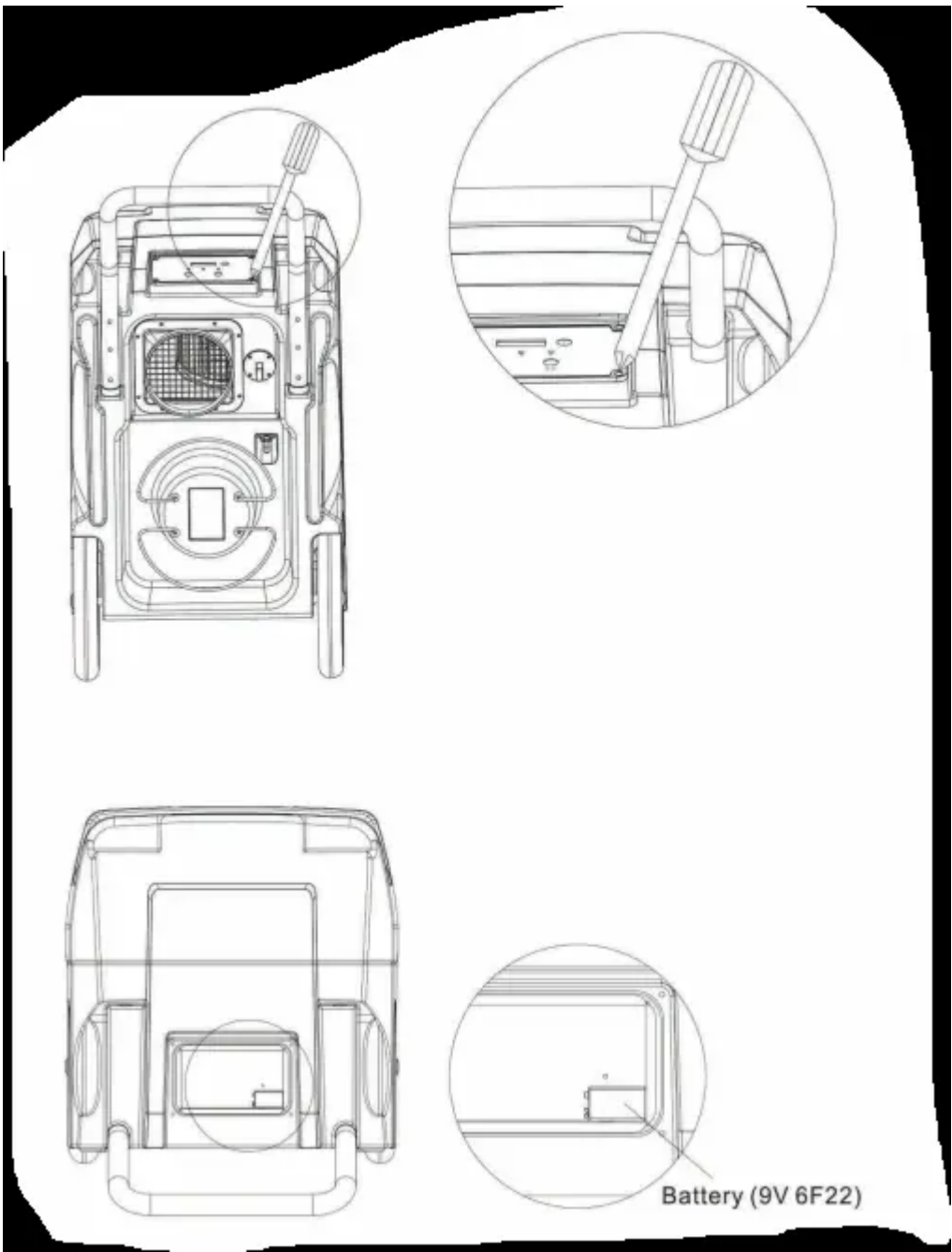

TROUBLESHOOTING

PROBLEM	CAUSE	SOLUTION
Dehumidifier does not operate	No power to appliance	Connect plug to power socket
	Switch not turned on	Switch on
	E4 error is displayed	Check drainage flow
Dehumidifier collects little water	Insufficient working time	Allow more working time
	Low ambient temperature	Increase ambient temperature
	Condensate hose is blocked	Check hose for restrictions
	Filter is blocked	Clean filter
Dehumidifier is operating but room is not drying	Doors and windows are open	Seal room from external areas

FAULT CODES

CODE	E1	E2	E3	E4
Error message	Coil sensor error	Humidity sensor error	Low or no refrigerant	Water pump fault or blockage
Display Reading	Flashes every 30 sec's	Flashes every 30 sec's	Flashes continually	Flashes continually
Reason	Timed defrost mode, the dehumidifier is working correctly	50% R.H displayed, continuous mode in operation	Turn OFF, the turn ON again.	Dehumidifier will turn OFF automatically, the fault must be rectified before operation can commence.

Warning

This content is compiled from multiple sources and is provided for reference purposes only. It may not be complete or fully applicable to all situations. If you are unable to resolve your issue, please contact the product manufacturer or an authorized service provider for official support.

Document generated by [ManualsFile](#)